

US00D670990S

(12) **United States Design Patent**  
**Kruse et al.**

(10) **Patent No.:** **US D670,990 S**

(45) **Date of Patent:** **\*\* Nov. 20, 2012**

(54) **MANUAL SHARPENER FOR TEETH OF CHAIN SAWS**

(75) Inventors: **Bernd Kruse**, Gummersbach (DE);  
**Klemens Schlimbach**,  
Neunkirchen-Seelscheid (DE)

(73) Assignee: **August Ruedgeberg GmbH & Co. KG**,  
Marienheide (DE)

(\*\*) Term: **14 Years**

(21) Appl. No.: **29/361,241**

(22) Filed: **May 7, 2010**

(51) **LOC (9) Cl.** ..... **08-05**

(52) **U.S. Cl.** ..... **D8/91**

(58) **Field of Classification Search** ..... D8/9-92;  
30/138; 76/31, 36, 80.5; 451/419; 407/29.15  
See application file for complete search history.

(56) **References Cited**

**U.S. PATENT DOCUMENTS**

2,601,227	A *	6/1952	Shebel	.....	76/36
2,705,430	A *	4/1955	Strandberg	.....	76/36
2,833,165	A *	5/1958	Irwin et al.	.....	76/31
3,172,306	A *	3/1965	Kephart, Jr.	.....	76/36
3,283,615	A *	11/1966	Kephart, Jr.	.....	76/36
3,349,460	A *	10/1967	Kephart, Jr.	.....	407/29.15
3,518,900	A *	7/1970	Gasner et al.	.....	76/36
D237,248	S *	10/1975	Santore	.....	D8/91
4,010,661	A *	3/1977	Fletcher	.....	76/36

D246,756	S *	12/1977	Smyth et al.	.....	D8/91
4,325,168	A *	4/1982	Swentzel	.....	76/80.5
4,327,605	A *	5/1982	Strojny	.....	76/80.5
4,584,745	A *	4/1986	Seiber	.....	76/80.5
4,864,897	A *	9/1989	Newman	.....	76/31
5,107,726	A *	4/1992	Wilhite et al.	.....	76/36
5,174,173	A *	12/1992	Granberg	.....	76/36

**OTHER PUBLICATIONS**

Chain Sharp CS-X. Downloaded Mar. 24, 2011 at [http://www.ruedgeberg.de/images/Neuheiten\\_2010\\_72dpi\\_se-en.pdf](http://www.ruedgeberg.de/images/Neuheiten_2010_72dpi_se-en.pdf).\*

\* cited by examiner

*Primary Examiner* — Philip S Hyder

*Assistant Examiner* — Roselynn Cody

(74) *Attorney, Agent, or Firm* — Browdy and Neimark, PLLC

(57) **CLAIM**

The ornamental design for a manual sharpener for teeth of chain saws, as shown and described.

**DESCRIPTION**

FIG. 1 is a front view of a manual sharpener for teeth of chain saws, showing our new design;

FIG. 2 is a rear view thereof;

FIG. 3 is a top view thereof;

FIG. 4 is a bottom view thereof;

FIG. 5 is a lateral view (right side) thereof;

FIG. 6 is a lateral view (left side) thereof; and,

FIG. 7 is a perspective view thereof.

**1 Claim, 7 Drawing Sheets**

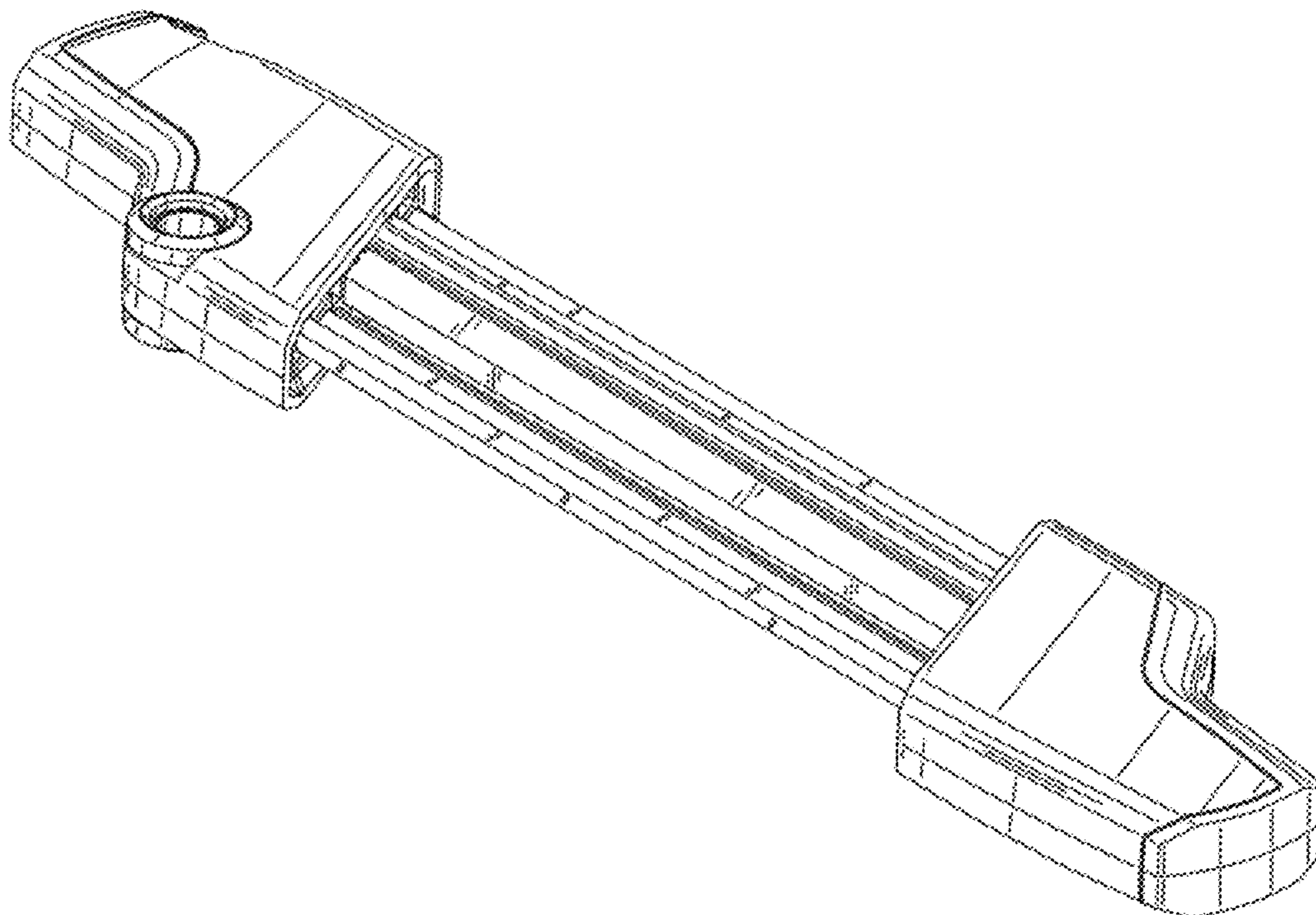

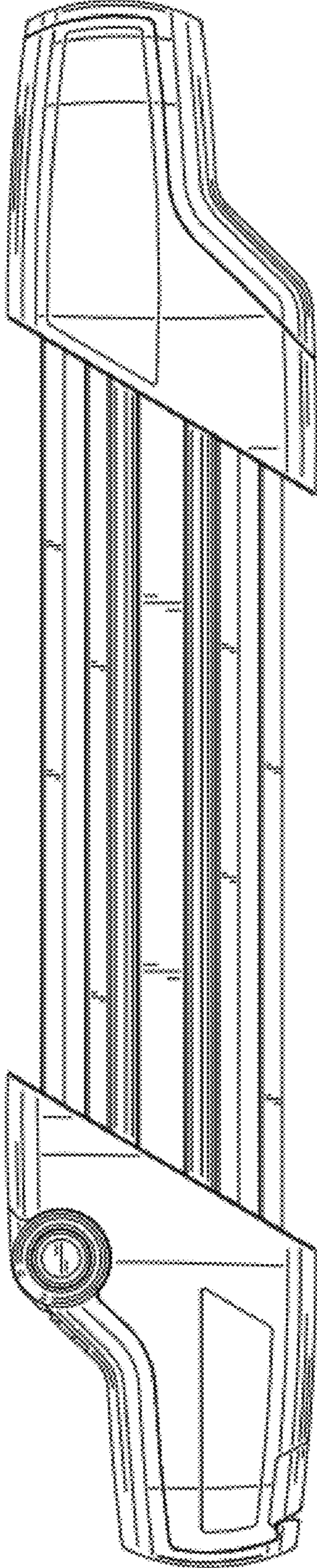

FIG. 1



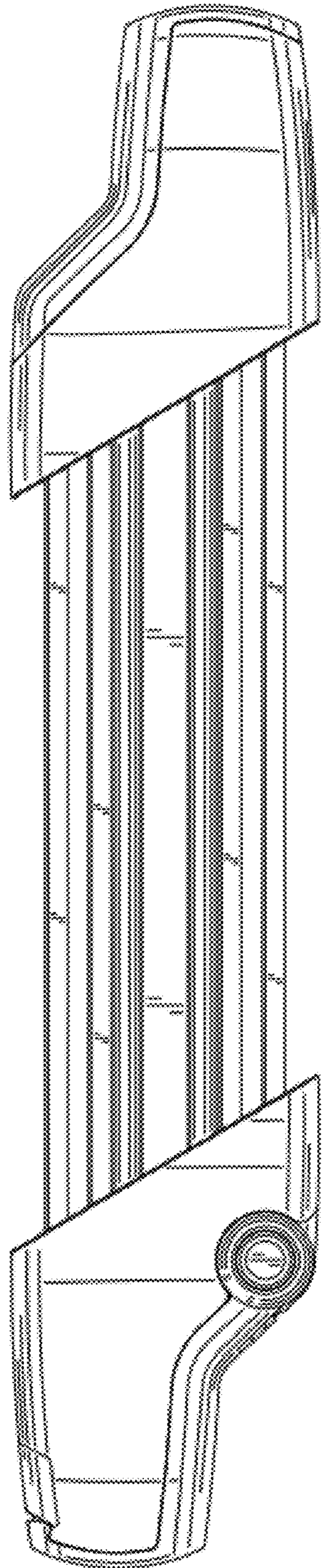

FIG. 2

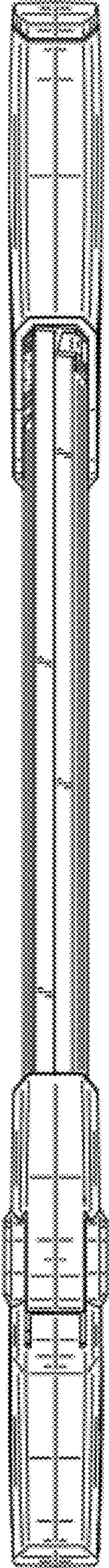

FIG. 3

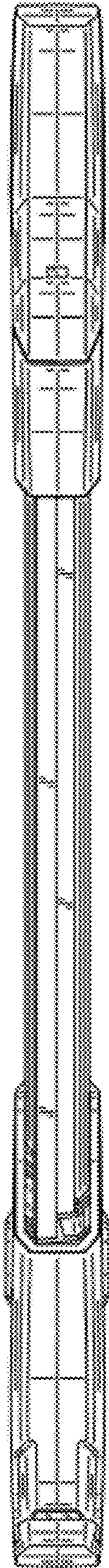

FIG. 4



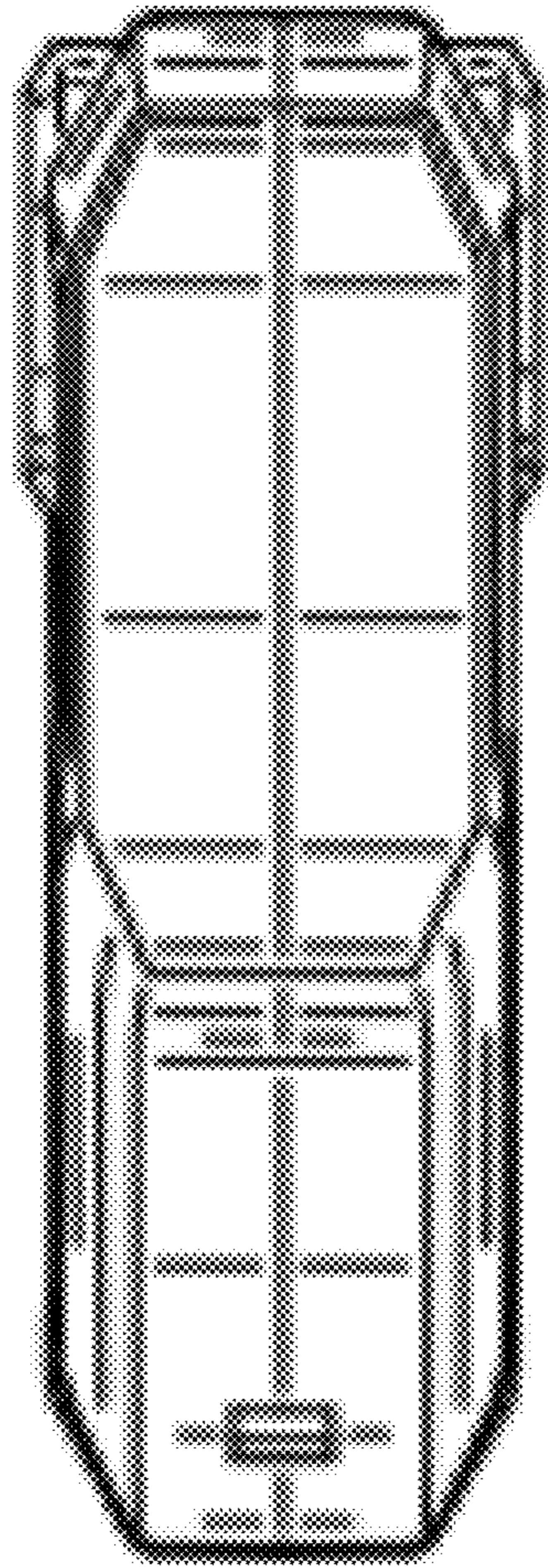

FIG. 5

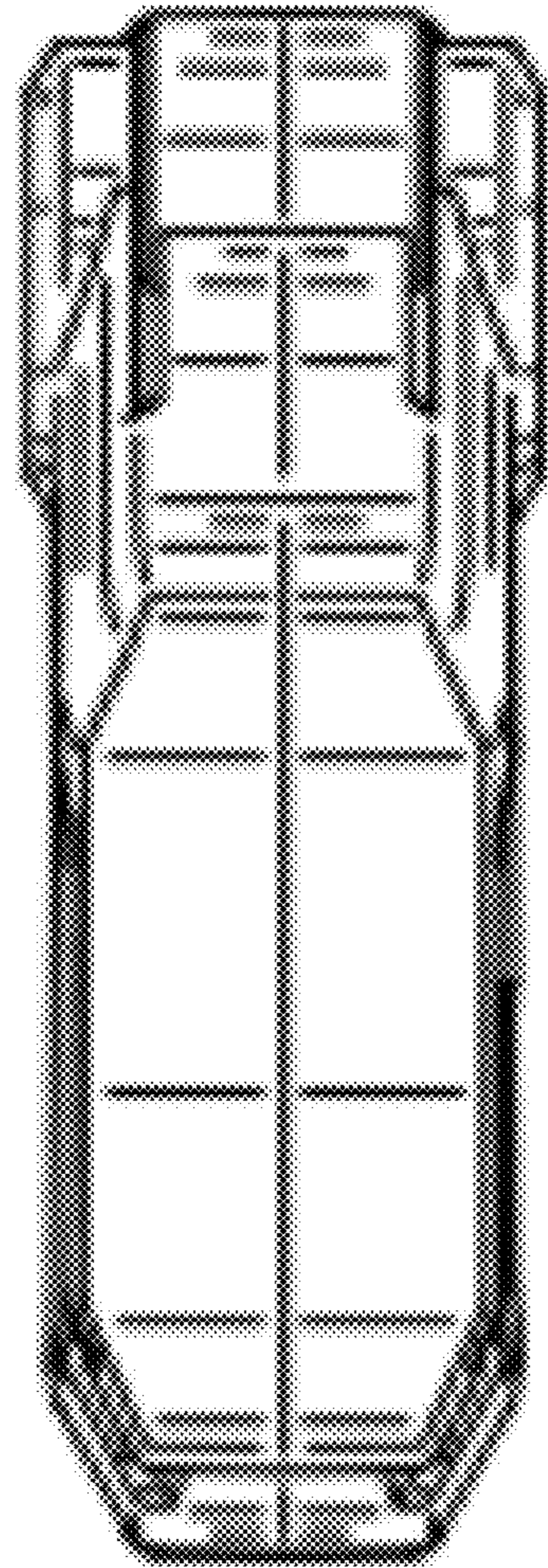

FIG. 6

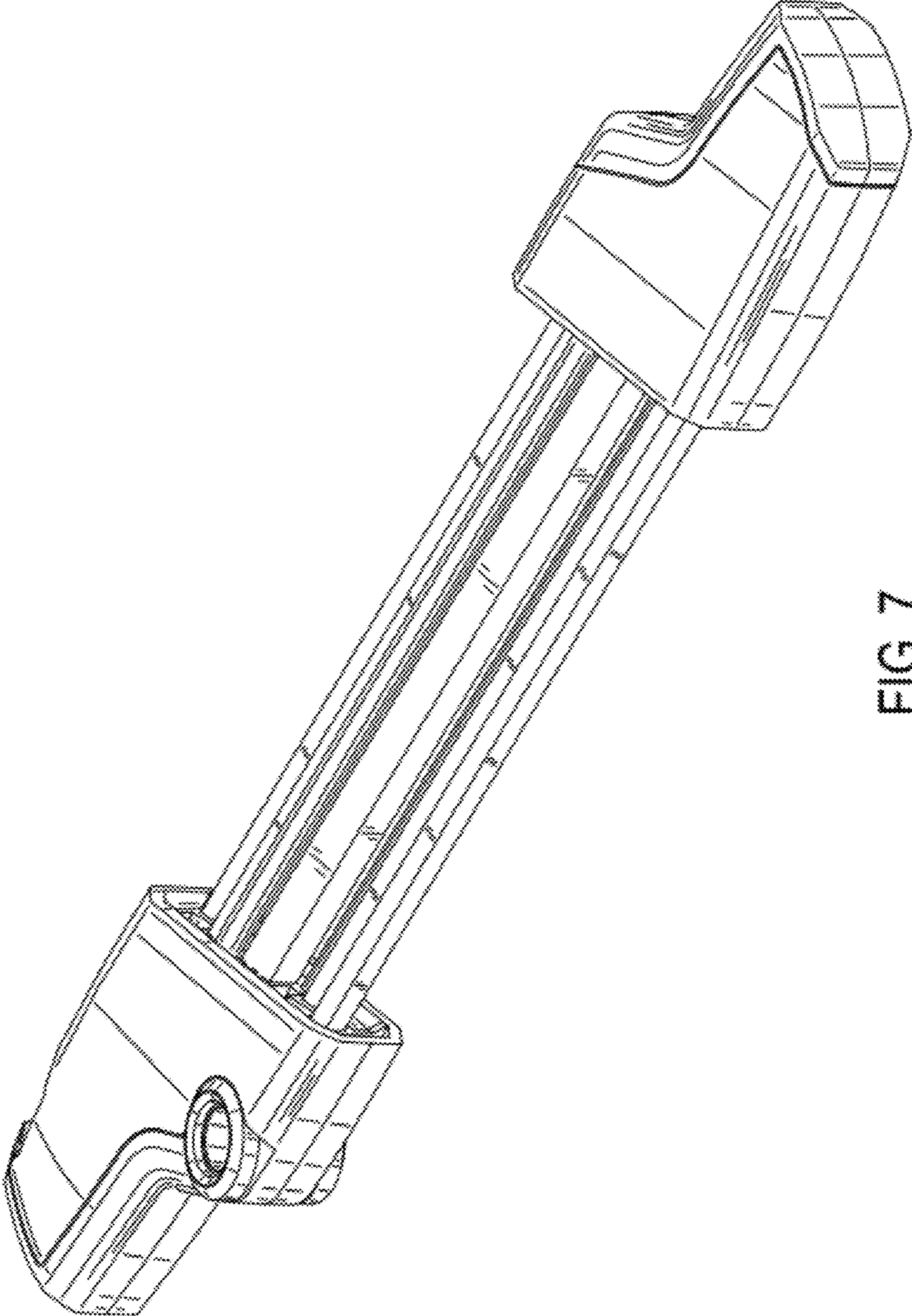

FIG. 7