



US00D670638S

(12) **United States Design Patent**
Goelet

(10) **Patent No.:** **US D670,638 S**
(45) **Date of Patent:** **** Nov. 13, 2012**

(54) **AIRSHIP**

(75) Inventor: **John Goelet**, Washington, DC (US)

(73) Assignee: **LTA Corporation**, New York, NY (US)

(**) Term: **14 Years**

(21) Appl. No.: **29/366,163**

(22) Filed: **Jul. 20, 2010**

(51) **LOC (9) Cl.** **12-07**

(52) **U.S. Cl.** **D12/319; D12/323**

(58) **Field of Classification Search** D12/327,
D12/326, 328, 329, 330, 319, 343, 324, 323;
244/96, 29, 26, 25, 17.17, 116, 115; D23/377;
D21/827, 583, 558, 453, 442, 440
See application file for complete search history.

(56) **References Cited**

U.S. PATENT DOCUMENTS

1,027,590	A	5/1912	Bucher	
1,944,467	A	1/1934	Sabin	
D166,475	S	* 4/1952	Lewis	D12/341
2,935,275	A	5/1960	Grayson	
3,432,120	A	3/1969	Guerrero	
D213,731	S	4/1969	Hsi	
3,477,168	A	11/1969	Trodglen, Jr.	
3,580,636	A	5/1971	Setto	
RE28,454	E	6/1975	Fitzpatrick et al.	
3,970,270	A	7/1976	Pittet, Jr.	
3,971,533	A	7/1976	Slater	
3,976,265	A	8/1976	Doolittle	
4,032,085	A	* 6/1977	Papst	244/30
4,085,912	A	4/1978	Slater	
4,204,656	A	* 5/1980	Seward, III	244/30
4,326,681	A	4/1982	Eshoo	
4,461,436	A	7/1984	Messina	
D274,999	S	8/1984	Reeves	
D280,194	S	8/1985	Bothe	
D288,216	S	* 2/1987	Jensen	D21/440
4,685,640	A	8/1987	Warrington et al.	
D305,418	S	1/1990	Blake	

(Continued)

FOREIGN PATENT DOCUMENTS

CA 1054124 A1 5/1979
(Continued)

OTHER PUBLICATIONS

21st Century Airships Web Site, accessed Jun. 22, 2007, <http://www.21stcenturyairships.com> (1 page).

(Continued)

Primary Examiner — Austin Murphy

(74) *Attorney, Agent, or Firm* — Finnegan, Henderson, Farabow, Garrett & Dunner, L.L.P.

(57) **CLAIM**

The ornamental design for an airship, as shown and described.

DESCRIPTION

FIG. 1 is the bottom view of an airship showing my new design;

FIG. 2 is a top plan view thereof;

FIG. 3 is a lower right perspective view thereof;

FIG. 4 is a front view thereof;

FIG. 5 is a rear view thereof;

FIG. 6 is a right side view thereof;

FIG. 7 is a left side view thereof;

FIG. 8 is a left side view thereof, showing the airship in an alternate configuration with cargo compartments deployed; and,

FIG. 9 is a left side view thereof, showing the airship in an alternate configuration with the tail section retracted into the hull section.

The broken line shown in the drawings represent portions of the airship that form no part of the claimed design. The cross-hatched area depicts a panel on the top surface of the airship. The broken lines immediately adjacent to the perimeter of the cross-hatched area indicate the boundary of the panel.

1 Claim, 9 Drawing Sheets

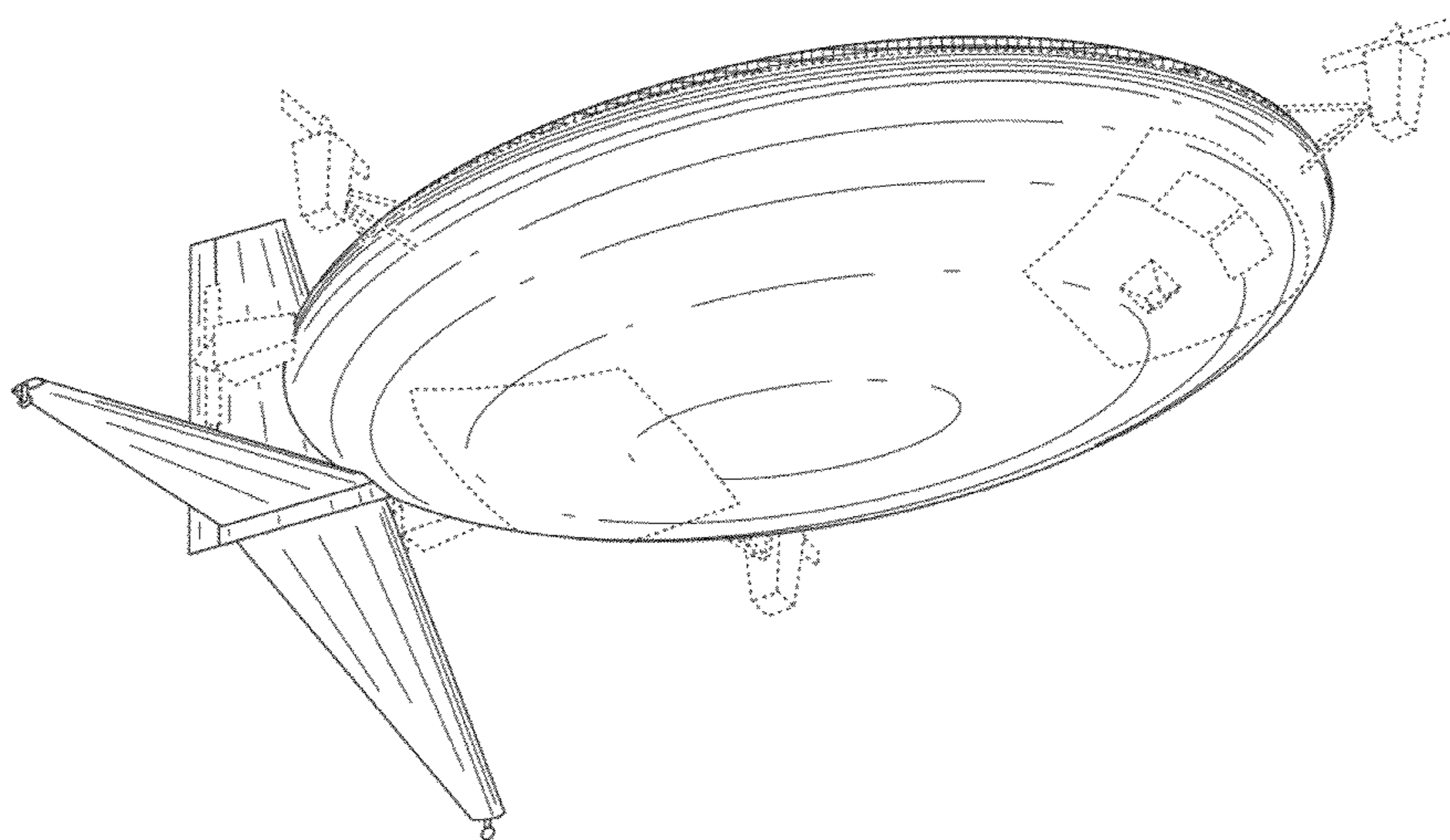

US D670,638 S

U.S. PATENT DOCUMENTS			DE	20204023 U1	7/2002
4,901,948 A	2/1990	Panos	DE	10120232 A1	10/2002
D307,131 S	4/1990	Kramer	DE	10121854 C1	11/2002
4,914,976 A	4/1990	Wyllie	DE	10139877 A1	2/2003
D307,884 S	5/1990	Ninkovich	DE	10148589 A1	4/2003
D309,887 S	8/1990	Ninkovich	DE	10148590 A1	4/2003
5,005,783 A *	4/1991	Taylor 244/97	DE	10201133 A1	7/2003
5,096,141 A	3/1992	Schley	DE	10210541 A1	9/2003
5,170,963 A	12/1992	Beck, Jr.	DE	10210542 A1	9/2003
5,178,344 A *	1/1993	Dlouhy 244/12.2	DE	10216480 A1	10/2003
5,240,206 A	8/1993	Omiya	DE	10226868 A1	12/2003
5,348,251 A	9/1994	Ferguson	DE	10228048 A1	1/2004
5,351,911 A	10/1994	Neumayr	DE	10252895 A1	5/2004
5,368,256 A	11/1994	Kalisz et al.	DE	10252896 A1	5/2004
D359,471 S *	6/1995	Cuccias et al. D12/323	DE	10252908 A1	5/2004
5,516,060 A	5/1996	McDonnell	DE	10252909 A1	5/2004
5,755,402 A	5/1998	Henry	DE	10252910 A1	5/2004
5,823,468 A	10/1998	Bothe	DE	10252911 A1	5/2004
5,906,335 A	5/1999	Thompson	DE	10 2005 013529	6/2007
D418,804 S	1/2000	Glasgow et al.	EP	0095763 A2	12/1983
6,010,093 A	1/2000	Paulson	EP	0 282 425 A1	9/1988
6,019,312 A	2/2000	Blenn	EP	0 291 355 A2	11/1988
D424,508 S	5/2000	Hankinson et al.	EP	0 503 801 A2	9/1992
6,164,589 A	12/2000	Kalisz	EP	0 619 792 B1	10/1994
6,196,498 B1	3/2001	Eichstedt et al.	EP	0 714 362 B1	6/1996
6,231,007 B1	5/2001	Schäfer	EP	0 729 423 B1	9/1996
6,270,036 B1 *	8/2001	Lowe, Jr. 244/12.2	EP	0 745 045 B1	12/1996
6,286,783 B1	9/2001	Keunkler	EP	1 070 008 B1	1/2001
6,293,493 B1	9/2001	Eichstedt et al.	EP	1 160 156 A2	12/2001
6,302,357 B1	10/2001	Kalisz	EP	1 292 474 B1	3/2003
6,311,925 B1	11/2001	Rist	EP	1 294 608 B1	3/2003
6,315,242 B1	11/2001	Eichstedt et al.	EP	1 451 063 B1	9/2004
6,328,257 B1	12/2001	Schäfer	EP	1 529 726 A2	5/2005
6,371,409 B1 *	4/2002	Steele 244/30	EP	1 770 009 A2	4/2007
6,398,159 B1 *	6/2002	Di Stefano 244/17.11	FR	2630397 A1	10/1989
6,565,037 B1	5/2003	Tonkovich	FR	2830838 B1	4/2003
6,648,272 B1	11/2003	Kothmann	GB	2 197 276 A	5/1988
6,659,838 B1	12/2003	Anderson	GB	2 250 007 A	5/1992
6,880,783 B2	4/2005	Munk	GB	2 275 036 A	8/1994
6,966,523 B2	11/2005	Colting	GB	2 278 815 A	12/1994
7,040,572 B2	5/2006	Munk	GB	2 300 010 A	10/1996
7,055,777 B2	6/2006	Colting	GB	2359534 A	8/2001
7,108,228 B1	9/2006	Marshall	GB	2 366 274 A	3/2002
7,137,592 B2	11/2006	Barocela et al.	RU	1799335 A3	2/1993
7,156,342 B2	1/2007	Heaven, Jr. et al.	RU	37568 S0	10/1993
7,159,817 B2	1/2007	VanderMey et al.	RU	2009073 C1	3/1994
7,448,572 B2 *	11/2008	Marimon et al. 244/30	RU	40822 S	1/1995
D583,294 S	12/2008	Balaskovic	RU	2028249 C1	2/1995
7,490,794 B2 *	2/2009	Heaven, Jr. 244/125	RU	2070136 C1	12/1996
D630,155 S *	1/2011	Buckley D12/323	RU	2092381 C1	10/1997
7,866,601 B2 *	1/2011	Balaskovic 244/96	RU	2098318 C1	12/1997
8,070,096 B2 *	12/2011	Wood et al. 244/116	RU	2111146	5/1998
8,177,161 B2 *	5/2012	Morehead et al. 244/100 A	RU	2111147 C1	5/1998
D663,255 S *	7/2012	Pasternak D12/319	RU	2114027 C1	6/1998
2002/0003189 A1	1/2002	Kuenkler	RU	2141911 C1	11/1999
2002/0109045 A1	8/2002	Beach et al.	RU	2196703 C2	1/2003
2003/0001044 A1	1/2003	Munk	RU	2249536 C1	4/2005
2003/0127557 A1	7/2003	Anderson et al.	RU	2250122 C1	4/2005
2003/0234320 A1	12/2003	Colting	UA	10870 A	12/1996
2004/0162000 A1	8/2004	Anderson	UA	32397 A	12/2000
2005/0277359 A1	12/2005	Anderson	UA	55928 A	4/2003
2006/0016930 A1	1/2006	Pak	WO	WO 92/06002 A1	4/1992
2006/0060695 A1	3/2006	Walden et al.	WO	WO 93/13979 A1	7/1993
2006/0065777 A1	3/2006	Walden et al.	WO	WO 93/24364 A2	12/1993
2006/0151666 A1	7/2006	VanderMey et al.	WO	WO 95/05307 A1	2/1995
2006/0227013 A1	10/2006	Harvison et al.	WO	WO 95/14607 A1	6/1995
2006/0261213 A1	11/2006	Lavan	WO	WO 95/22486 A1	8/1995
2006/0284002 A1	12/2006	Stephens et al.	WO	WO 95/27652 A1	10/1995
2007/0295859 A1	12/2007	Colvin	WO	WO 95/32893 A1	12/1995
2008/0179454 A1	7/2008	Balaskovic	WO	WO 95/32894 A1	12/1995
			WO	WO 96/38340 A1	12/1996
			WO	WO 97/15492 A2	5/1997
			WO	WO-97/49606 A1	12/1997
			WO	WO-98/28188 A1	7/1998
			WO	WO 98/29303 A2	7/1998
			WO	WO 98/31589 A1	7/1998
			WO	WO 99/67131 A1	12/1999
			WO	WO 00/48902 A1	8/2000
			WO	WO 00/73142 A2	12/2000

FOREIGN PATENT DOCUMENTS

DE	210003	5/1909
DE	2640433 C2	4/1977
DE	3508101 A1	9/1986
DE	10011319 A1	9/2001
DE	20116152 U1	2/2002
DE	10058072 A1	6/2002

WO	WO 01/42082	A1	6/2001
WO	WO 01/68447	A2	9/2001
WO	WO 01/94172	A1	12/2001
WO	WO 03/047967	A1	6/2003
WO	WO 03/055745	A1	7/2003
WO	WO 03/055746	A1	7/2003
WO	WO 03/074356	A3	9/2003
WO	WO 03/097450	A1	11/2003
WO	WO 03/097451	A1	11/2003
WO	WO 2004/000642	A1	12/2003
WO	WO 2004/074091	A2	9/2004
WO	WO 2004/087499	A2	10/2004
WO	WO 2005/002960	A1	1/2005
WO	WO 2005/007508	A1	1/2005
WO	WO 2006/061617	A1	6/2006
WO	WO 2006/085919	A2	8/2006
WO	WO 2006/137880	A2	12/2006
WO	WO 2007/036038	A1	4/2007
WO	WO 2007/037932	A2	4/2007
WO	WO 2007/045091	A1	4/2007
WO	WO 2007/065649	A2	6/2007

OTHER PUBLICATIONS

- ALA-40 proof-of-concept—Thermoplane, Photos from “Janes—All the World’s Aircraft,” 1997 (2 pages).
- Ben Ionnatta, “Spy Blimps and Heavy Lifters: The Latest Thing in Airships,” *Air & Space Smithsonian*, Sep. 2007 (2 pages).
- Blimp Europa N2A Web Site, accessed Oct. 11, 2006, machine translated Jun. 25, 2007, <http://www.blimp-n2a.com/cl5alpha.htm> (3 pages).
- CargoLifter Web Site, accessed Jun. 19, 2007 <http://cargolifter.info> (2 pages).
- Daniel P. Raymer, “Aircraft Design: A Conceptual Approach,” 4th Ed., 2006, pp. 652-659, American Institute of Aeronautics and Astronautics, Inc., Reston, Virginia (11 pages).
- Demonstrator Alpha, Lenticular Aircraft of Air Photography, accessed Oct. 11, 2006, machine translated Jun. 25, 2007, <http://perso.orange.fr/balaskovic/actu-texte.html> (2 pages).
- Dynalifter Web Site, accessed Jun. 22, 2007, <http://www.dynalifter.com> (7 pages).
- “Lift Equations,” derived from “The Non-Rigid Airship Test And Evaluation Manual,” U.S. Navy, 1940 (2 pages).
- Michael A. Dornheim, “Skunks Working,” *Aviation Week*, Feb. 6, 2006, accessed Jun. 22, 2007, http://www.aviationweek.com/aw/generic/story_generic.jsp?channel=awst&id=news/020606p2.xml (2 pages).
- Gabriel A. Khoury and J. David Gillett, “Lenticular Mathematics,” an excerpt from “Airship Technology,” Cambridge University Press, 1999 (6 pages).
- Lord Ventry and Eugene Kolesnik, Excerpt from “Jane’s Pocket Book of Airships,” Collier Books, 1977, pp. 94-96.
- Edwin Mowforth, “Lenticular History,” an excerpt from “An Introduction to the Airship,” Second Edition, 2001, and information sheet (7 pages).
- Operation-LTA Web Site, accessed Oct. 11, 2006, <http://web.archive.org/web/20040405173243/www.operation-lta.com> (5 pages).
- Stephane Doncieux and Jean-Arcady Meyer, “Evolving Neural Networks for the Control of a Lenticular Blimp,” *AnimalLab—LIP6*, 2003, France, <http://animallab.lip6.fr> (12 pages).
- Thomas F. Norton, “Now There’s a ‘Personal Blimp.’ Unique Foldable Frame Makes it Practical as a Second Century Aircraft,” *General Aviation News*, Jan. 19, 2007, p. 18-19, 59th year, No. 2, Flyer Media, Inc., Lakewood, WA (2 pages).
- Worldwide Aeros Corporation Web Site, accessed Jun. 22, 2007, <http://www.aerosml.com> (4 pages).
- Yu. Boiko and V.A. Turian, “Dreamboat of Centuries,” *Moscow, Machine Building*, p. 52, Jun. 13, 1991 (2 pages), Fig. 32.
- U.S. Army Advanced Materiel Concepts Agency, “Aerial Very Heavy Lift Concepts for the 1990 Army Volume I,” Basic Report, Nov. 1969 (41 pages).
- U.S. Army Advanced Materiel Concepts Agency, “Aerial Very Heavy Lift Concepts for the 1990 Army Volume III,” Academic and Industrial Presentations, Nov. 1, 1969 (200 pages).
- Boeing Vertol Company for NASA Ames., “Feasibility Study of Modern Airships”, Final Report, vol. 1, May 1975 (478 pages).
- P.A. Mackrodt, “Further Studies in the Concept of Delta-Winged Hybrid Airships”, *J. Aircraft*, Oct. 1, 1980, pp. 734-740.
- Mark D. Ardema, “Missions and Vehicle Concepts for Modern, Propelled, Lighter-Than-Air Vehicles”, Agard, NATO, Feb. 1985 (50 pages).
- Dr. R.S. Ross et al., “New Air Transport System for Heavy Bulky Cargo” (Advanced Copy), Apr. 20, 1962 (35 pages).
- W.L. Marcy, “Parametric Design Study of Fully-Buoyant Naval Air Vehicles”, NADC, Nov. 30, 1976 (85 pages).
- Steppler, Richard M., “Return to Lighter Than Air Transportation for Military and Civilian Application”, Defense Systems Management School, Fort Belvoir, VA, Nov. 1973 (56 pages).
- L. Balis Crema et al., “Some Trends in Airship Technology Developments”, NATO, Apr. 10-15, 1983 (14 pages).
- “Types of Lighter-Than-Air Aircraft,” Author unknown, Publication date unknown (34 pages).
- Mark D. Ardema, “Vehicle Concepts and Technology Requirements for Buoyant Heavy-Lift Systems”, NASA, 1979 (36 pages).
- Mark D. Ardema, “Vehicle Concepts and Technology Requirements for Buoyant Heavy-Lift Systems”, NASA Technical Paper, 1981 (18 pages).
- David Bailey and William Mueller, “North Warning Airship Program, Final Overview,” Naval Air Development Center, Apr. 6, 1987 (223 pages).
- “Preliminary Design Investigation for New Payload and Ground Handling Concepts for Airships Operating in Remote Arctic Regions, Final Report,” Naval Air Development Center, Mar. 31, 1986 (224 pages).
- Capt. J. Arvi et al., “North Warning Program Airship Feasibility Tests, Final Report,” Naval Air Development Center, Feb. 20, 1987 (41 pages).
- Capt. J. Arvi et al., “North Warning System Familiarisation, Feasibility and Operational Demonstration, Final Report,” Naval Air Development Center, Apr. 19, 1986 (126 pages).
- Douglas Botting, “The Giant Airships,” Time-Life Books, Alexandria, VA 1980 (186 pages).
- E. Udartsev and E. Tyan, “Dirigible of a New Generation in Kiev,” available at <http://www.avijournal.com/sections/journal/arh/maqazine/200112/index.html>, Dec. 2001. (9 pages), Machine Translation.
- Edwin Mowforth, “An Introduction to the Airship,” Third Edition, The Airship Association, Sep. 2007 (157 pages).
- Construction Cost Management Co., “With Us, Future Comes Faster,” available at <http://www.buildcostcontrol.com/Airship/tabid/640/Default.aspx>, 2008 (1 page).
- Future Flight?, Leslie Deane, *Ballooning, The Journal of the Balloon Federation of America*, Jul./Aug. 2008, pp. 26-32.
- Repoulias et al., “Dynamically Feasible Trajectory and Open-Loop Control Design for Unmanned Airships,” 2007 Mediterranean Conference on Control and Automation, Jul. 27, 2007, XP002511581, Athens, Greece.
- Nagabhushan et al., “Directional control of an advanced airship,” AIAA Lighter-Than-Air Systems Technology Conference, 11th, Clearwater Beach, FL, May 15-18, 1995, Technical Papers (A95-30317 07-01), Washington, DC, American Institute of Aeronautics and Astronautics, May 15, 1995, pp. 107-116.
- PCT International Search Report re PCT/US2007/021962, mailed Apr. 3, 2009.
- PCT International Search Report re PCT/US2008/009453, mailed Apr. 3, 2009.
- <http://dynalifter.com/>, accessed Dec. 1, 2009 (16 pages).
- <http://hybridairvehicles.net/index.html>, accessed Dec. 1, 2009 (23 pages).
- <http://www.skylifter.com.au/>, accessed Dec. 1, 2009 (17 pages).
- Luffman, “Aeroraft The Alternative Aircraft for Heavy Lift Transport or Crane Use,” American Institute of Aeronautics and Astronautics, AIAA’s 3rd Annual Aviation Technology, Integration, and Operations (ATIO) Tech, Nov. 17-19, 2003, Denver, Colorado, AIAA 2003-6754, pp. 1-13.
- European Examination Report from EP Application No. 08 827 387.5-1254, dated Jun. 6, 2010, (4 pages).

US D670,638 S

Page 4

European Examination Report from EP Application No. 07 873 810.1-2422, dated Aug. 16, 2010, (4 pages).

Office Action dated Sep. 3, 2009, from U.S. Appl. No. 11/907,883.

Final Office Action dated Apr. 1, 2010, from U.S. Appl. No. 11/907,883.

Advisory Action dated Aug. 3, 2010, from U.S. Appl. No. 11/907,883.

Amendment After Final dated Aug. 17, 2010, from U.S. Appl. No. 11/907,883.

Notice of Allowance dated Sep. 1, 2010, from U.S. Appl. No. 11/907,883.

U.S. Appl. No. 12/222,355, filed Aug. 7, 2008.

* cited by examiner

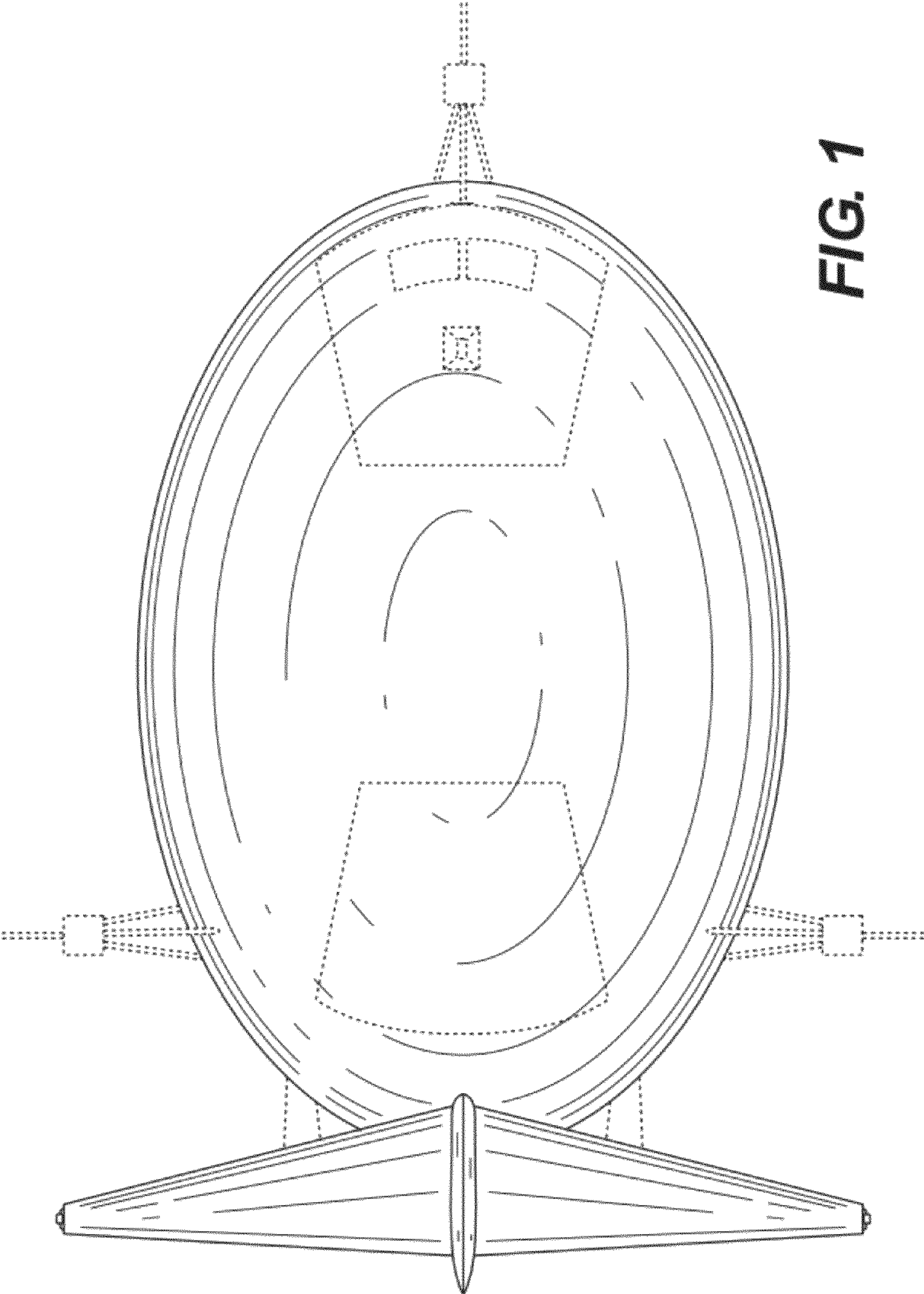

FIG. 1

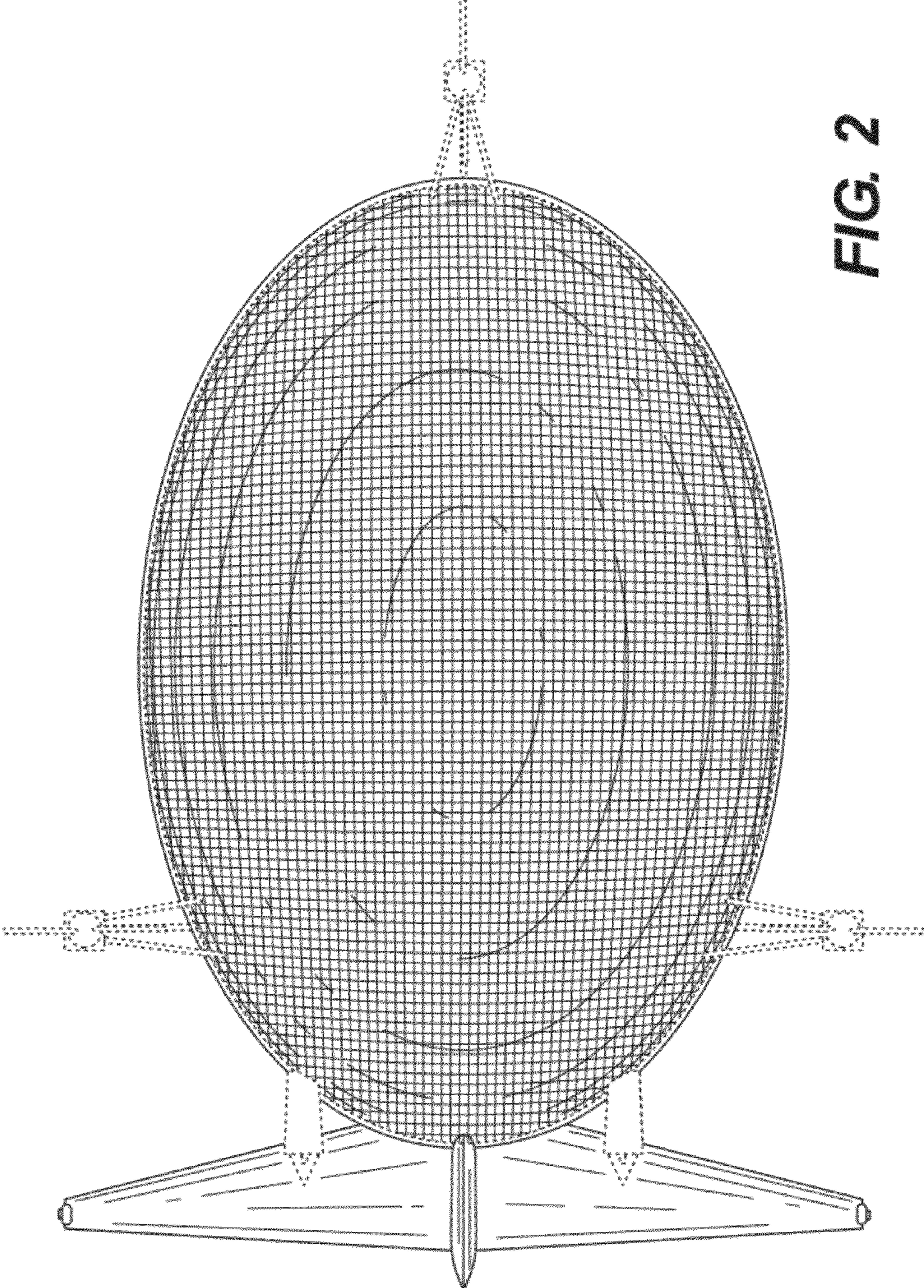

FIG. 2

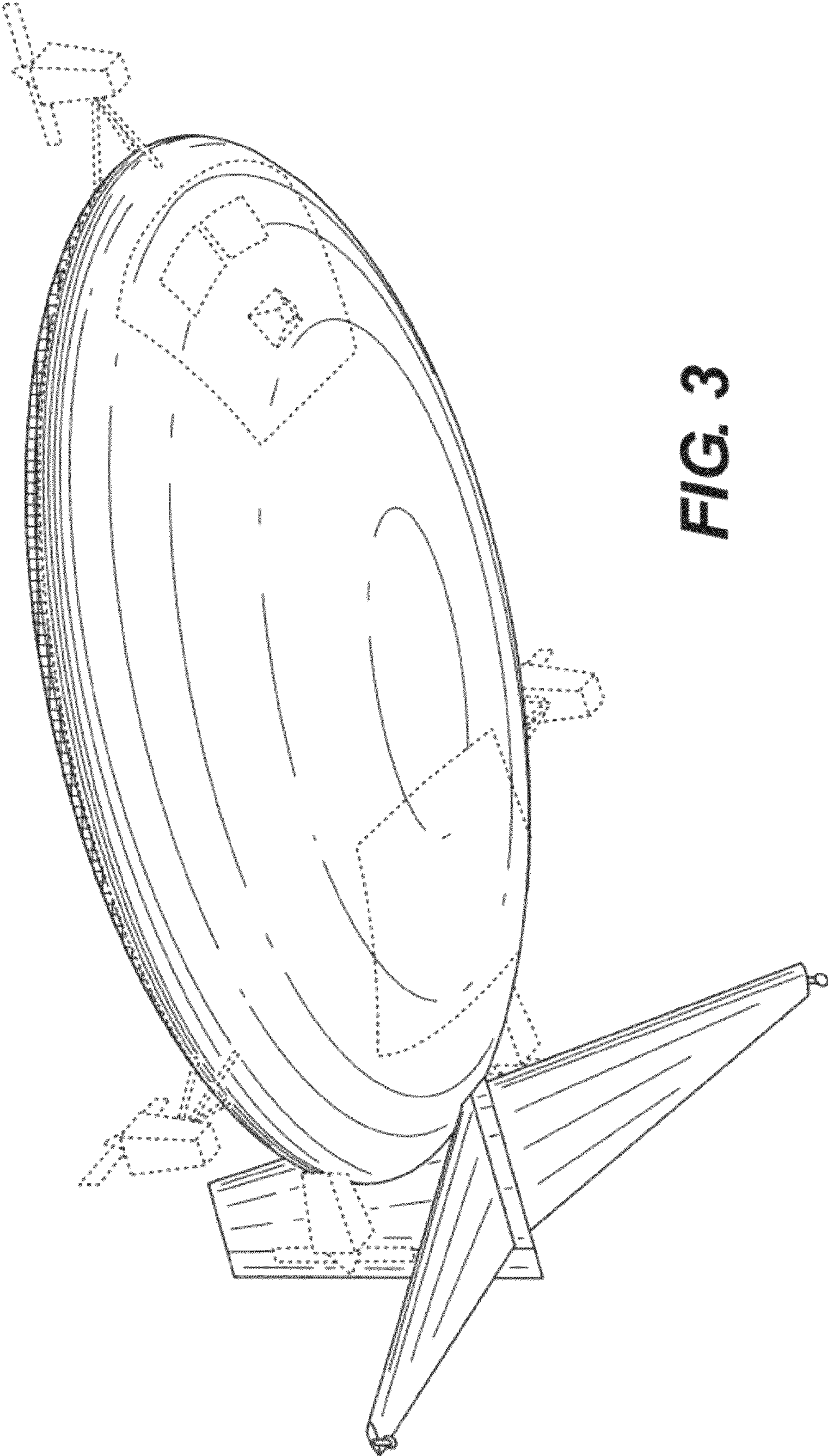

FIG. 3

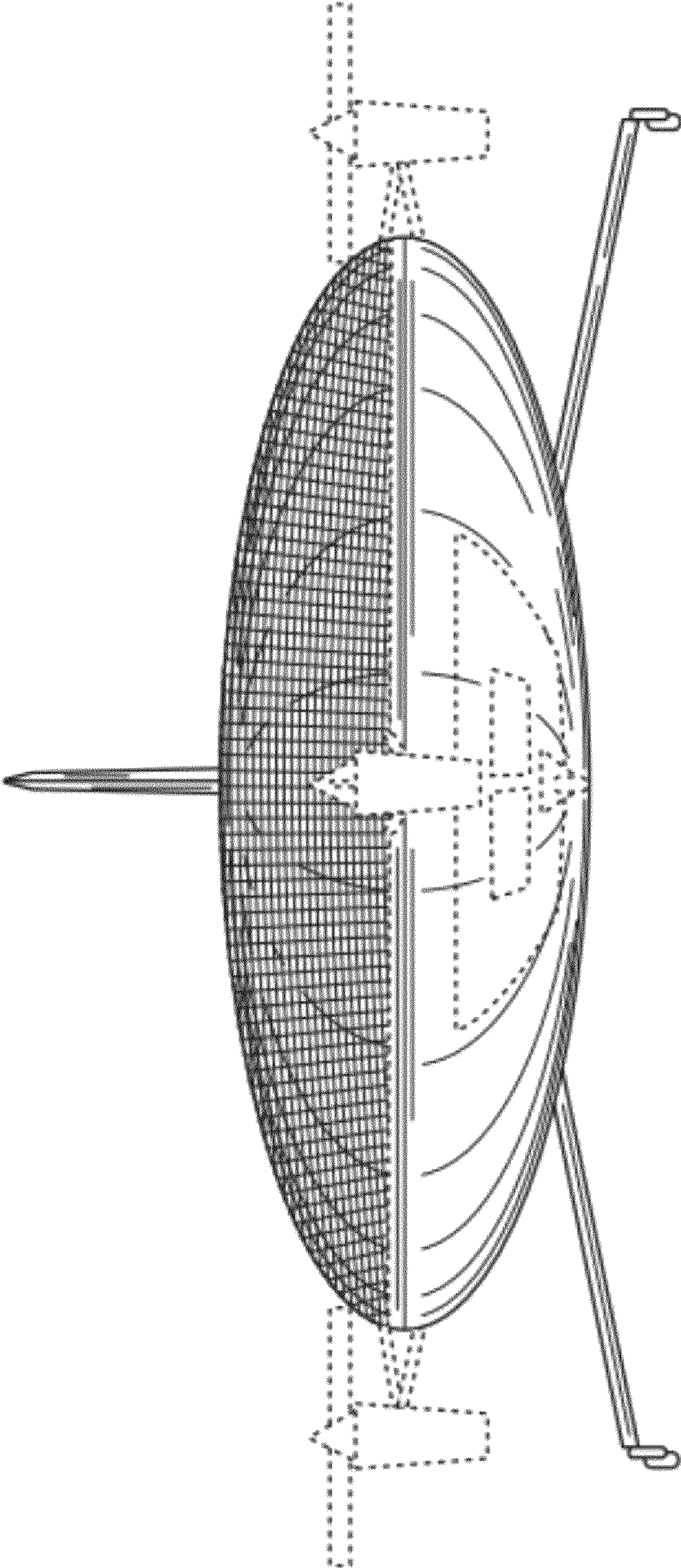

FIG. 4

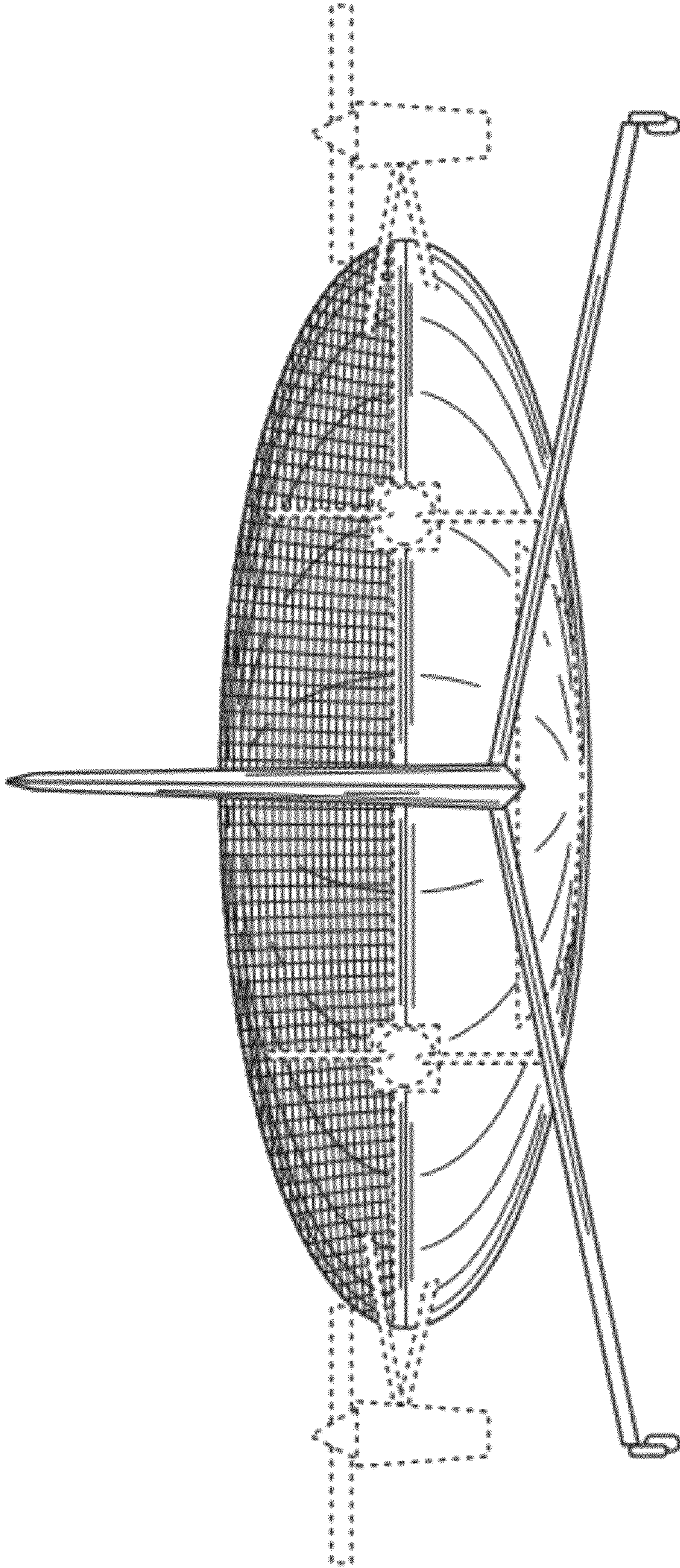

FIG. 5

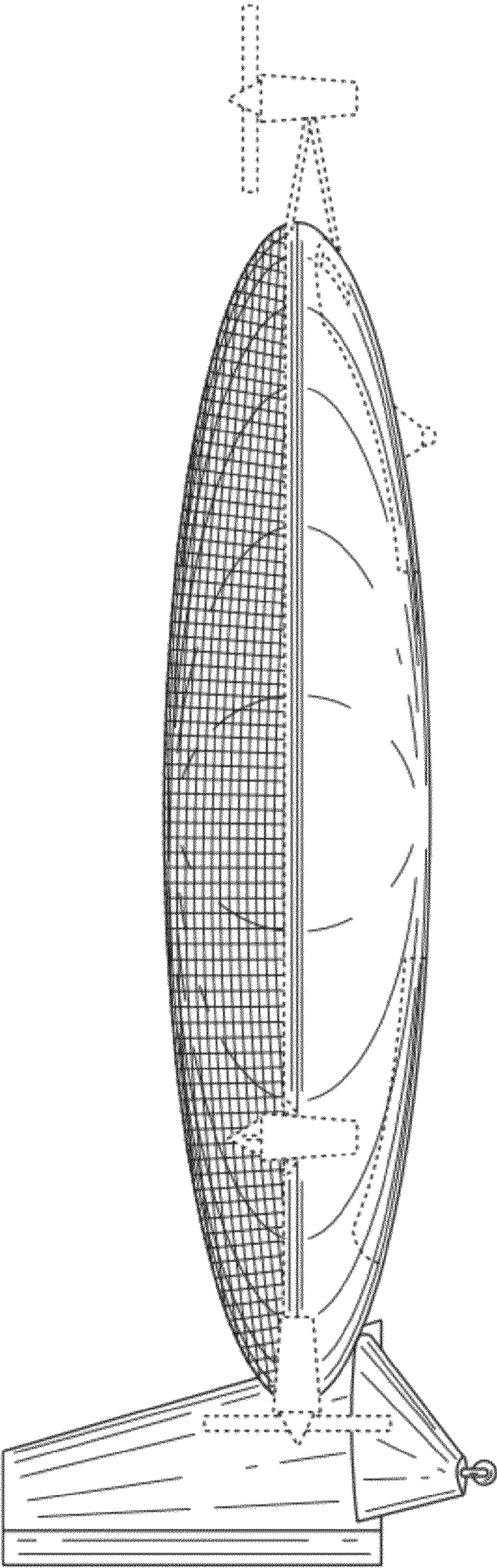

FIG. 6

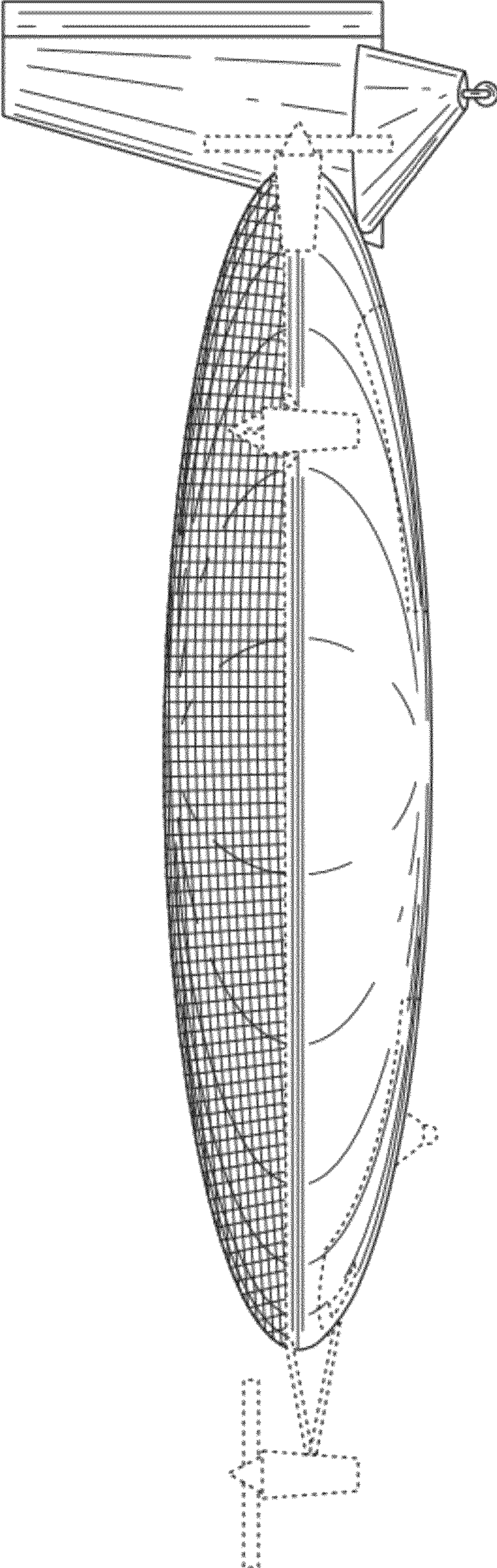

FIG. 7

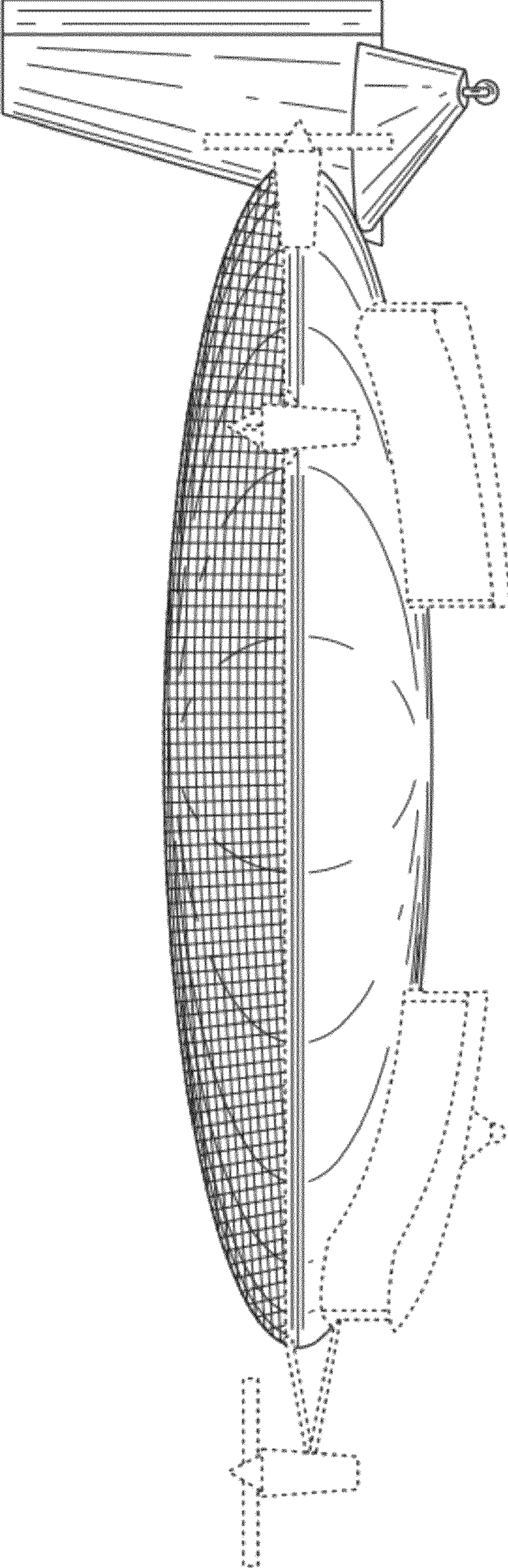

FIG. 8

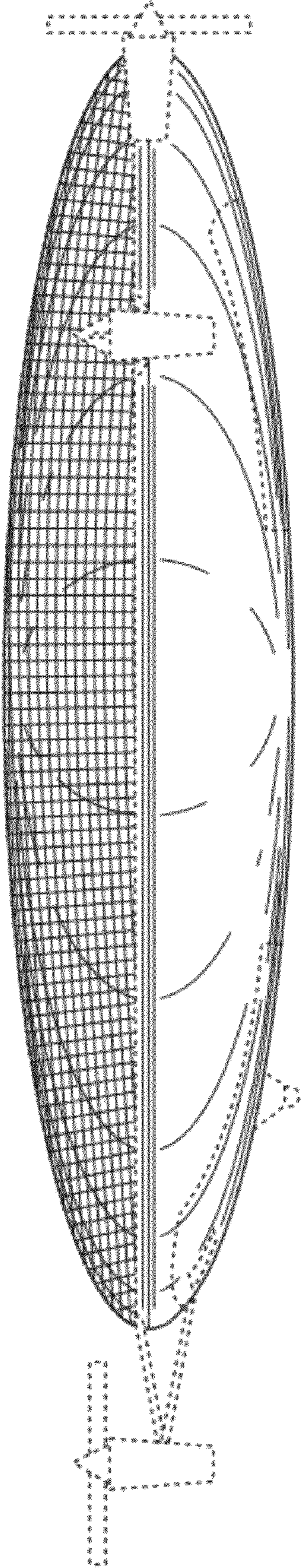

FIG. 9