

US00D670624S

(12) **United States Design Patent**
Koehl et al.

(10) **Patent No.:** **US D670,624 S**

(45) **Date of Patent:** **** Nov. 13, 2012**

(54) **FRONT BUMPER FOR A VEHICLE**

(75) Inventors: **Steffen Koehl**, Stuttgart (DE); **Minchul Koo**, Stuttgart (DE); **Toru Nakano**, Stuttgart (DE); **Frank Pfisterer**, Stuttgart (DE); **Il-Hun Yoon**, Stuttgart (DE)

(73) Assignee: **Daimler AG**, Stuttgart (DE)

(**) Term: **14 Years**

(21) Appl. No.: **29/371,283**

(22) Filed: **Dec. 20, 2010**

(30) **Foreign Application Priority Data**

Jun. 21, 2010 (DE) 402010003318

(51) **LOC (9) Cl.** **12-16**

(52) **U.S. Cl.** **D12/169**

(58) **Field of Classification Search** D12/169,
D12/196, 171, 216, 163, 86, 90-92; 293/102,
293/113, 115, 117, 120; 296/180.1, 180.2
See application file for complete search history.

(56) **References Cited**

U.S. PATENT DOCUMENTS

D503,133 S	3/2005	Pfeiffer et al.	
D507,991 S	8/2005	Pfeiffer et al.	
D514,026 S	1/2006	Pfeiffer et al.	
D550,594 S *	9/2007	Pfeiffer	D12/169
D578,451 S *	10/2008	Jodo et al.	D12/169
D580,314 S *	11/2008	Yamaji	D12/169
D586,705 S *	2/2009	Bauer et al.	D12/169
D589,414 S *	3/2009	Futschik et al.	D12/169
D605,096 S *	12/2009	Mueller	D12/169
D610,956 S *	3/2010	Truebsbach	D12/169

D623,566 S *	9/2010	Bauer et al.	D12/169
D625,230 S *	10/2010	Hirai et al.	D12/169
D626,473 S *	11/2010	Mueller	D12/169
D630,978 S *	1/2011	Koshino et al.	D12/169
D633,013 S *	2/2011	Bauer et al.	D12/169
D636,303 S *	4/2011	Frei et al.	D12/169

* cited by examiner

Primary Examiner — Melody N Brown

(74) *Attorney, Agent, or Firm* — Crowell & Moring LLP

(57) **CLAIM**

The ornamental design for a front bumper for a vehicle, as shown and described.

DESCRIPTION

This application contains subject matter related to the following co-pending U.S. design patent applications: application Ser. No. 29/371,282, filed herewith and entitled "Front Bumper for a Vehicle"; application Ser. No. 29/311,765, filed Jun. 15, 2009 and entitled "Vehicle and Vehicle Shaped Articles;" application Ser. No. 29/311,767, filed Jun. 15, 2009 and entitled "Front Portion of a Vehicle and Vehicle Shaped Articles;" and application Ser. No. 29/311,356, filed Feb. 27, 2009 and entitled "Front Bumper for a Vehicle."

FIG. 1 is a left perspective view of a front bumper for a vehicle according to our design, the right perspective view being mirror symmetrical;

FIG. 2 is a front view thereof;

FIG. 3 is a top view thereof;

FIG. 4 is a bottom view thereof;

FIG. 5 is a right side view thereof; and,

FIG. 6 is a left side view thereof.

The broken lines are for illustrative purposes only and form no part of the claimed design.

1 Claim, 2 Drawing Sheets

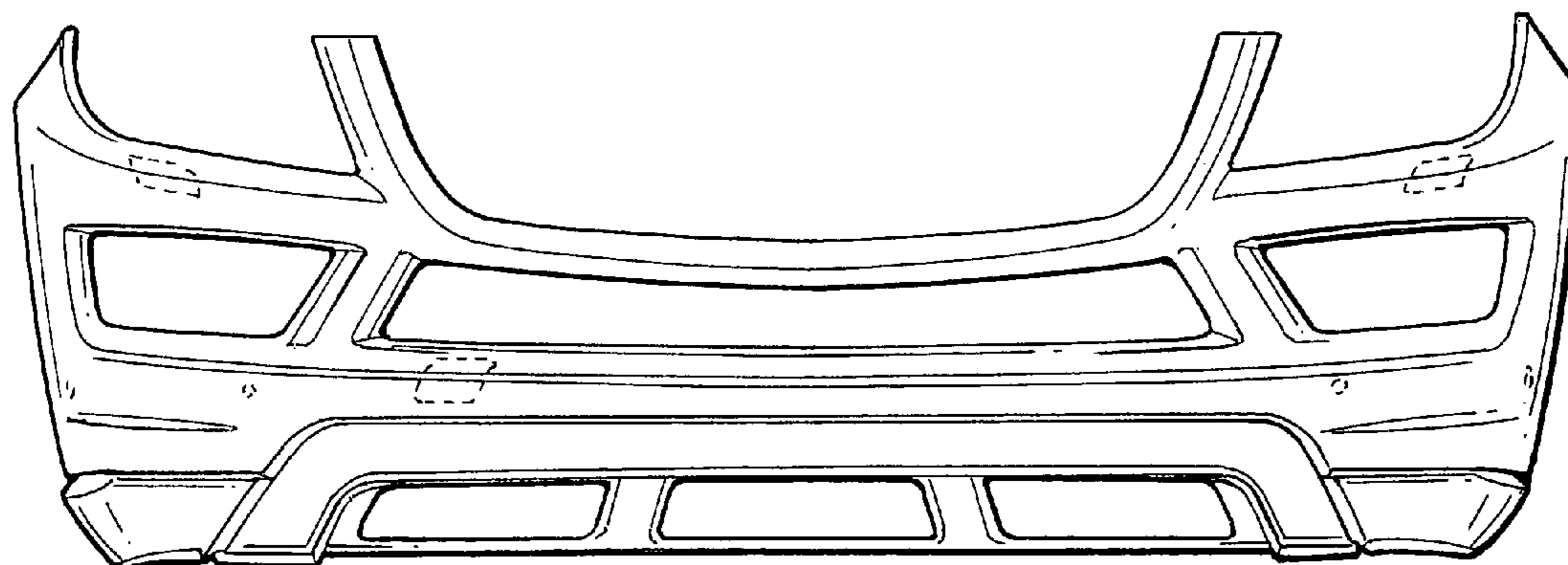

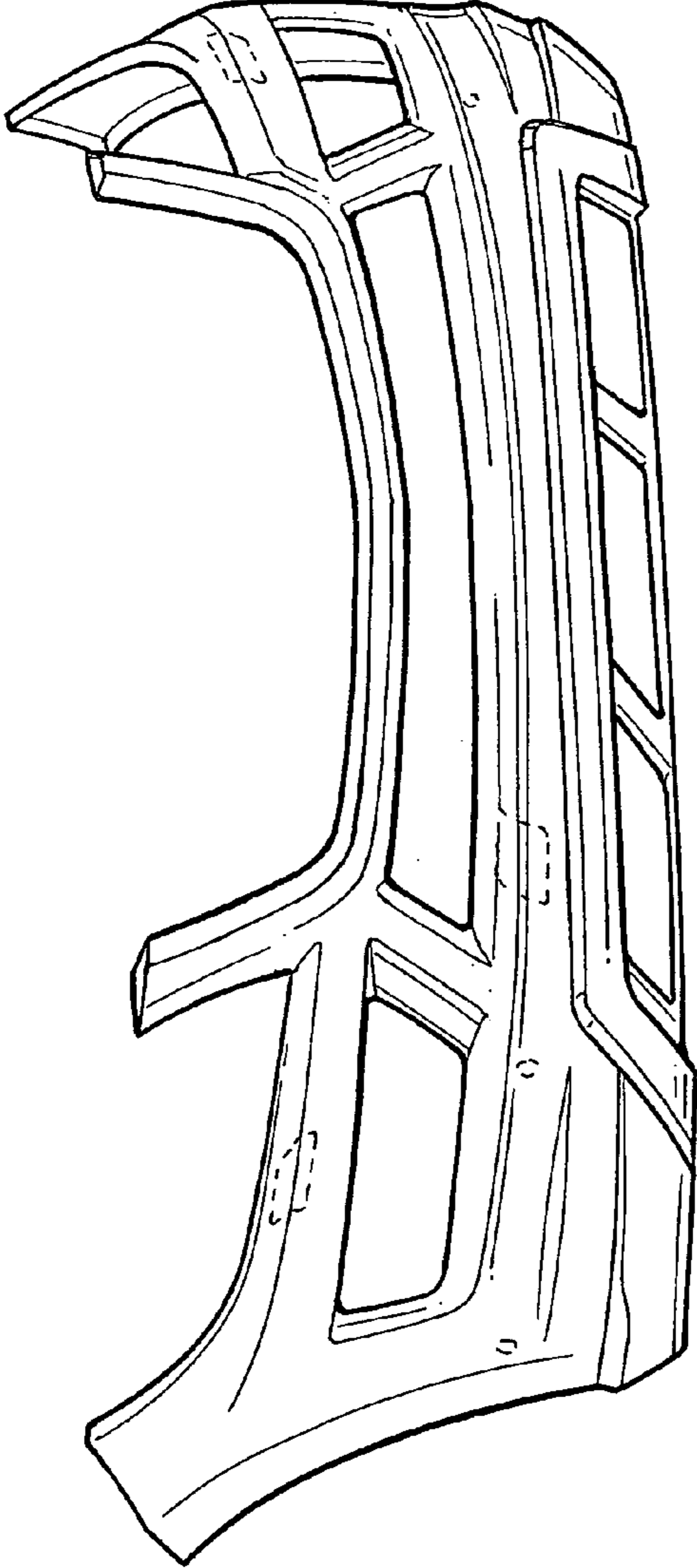

FIG. 1

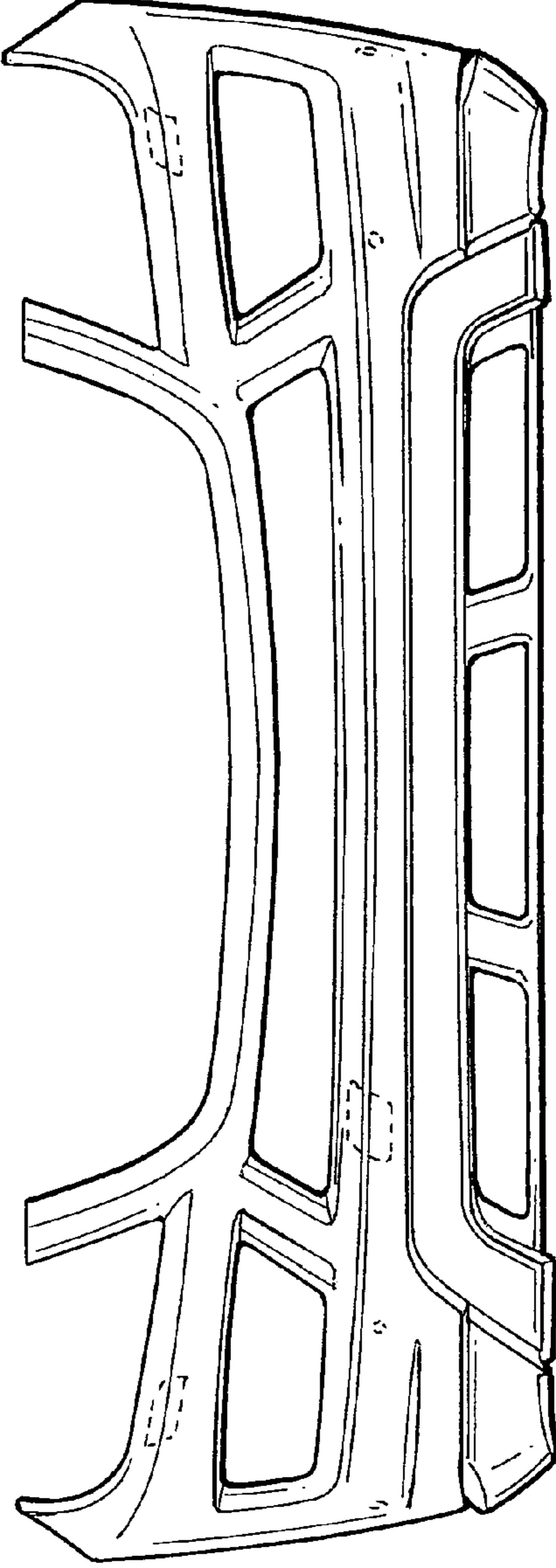

FIG. 2

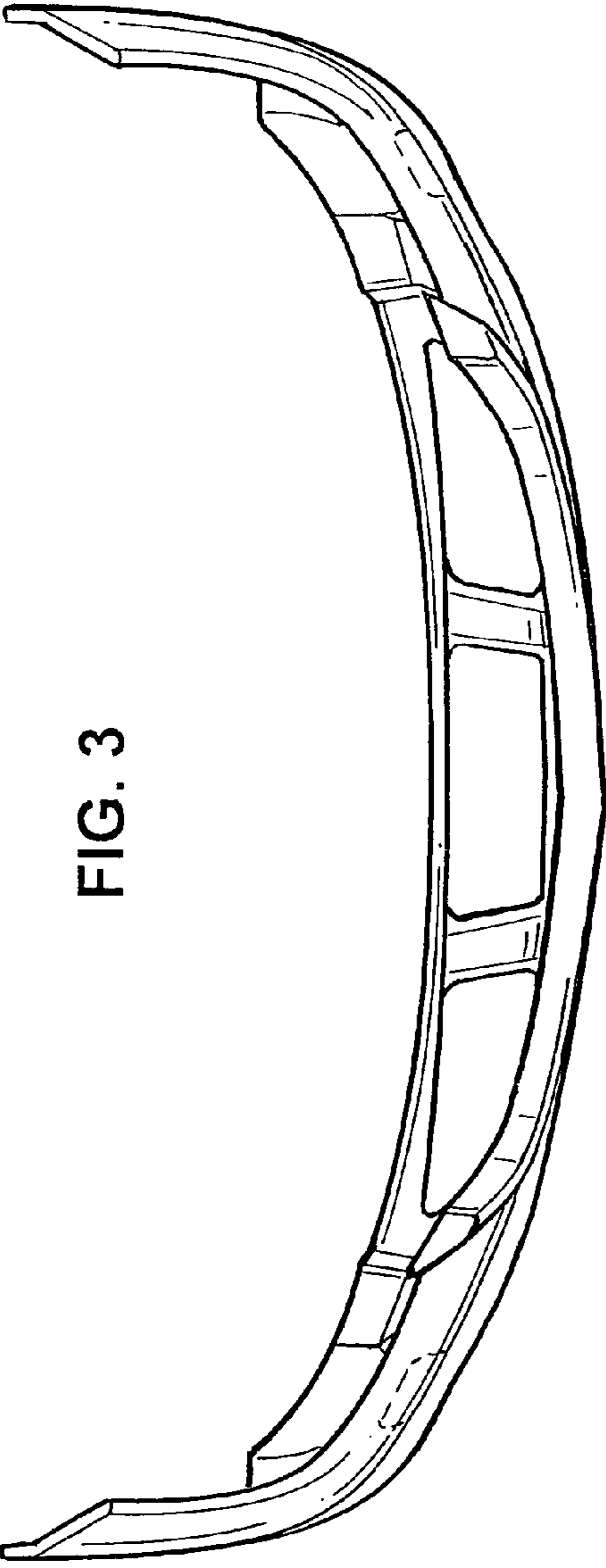

FIG. 3

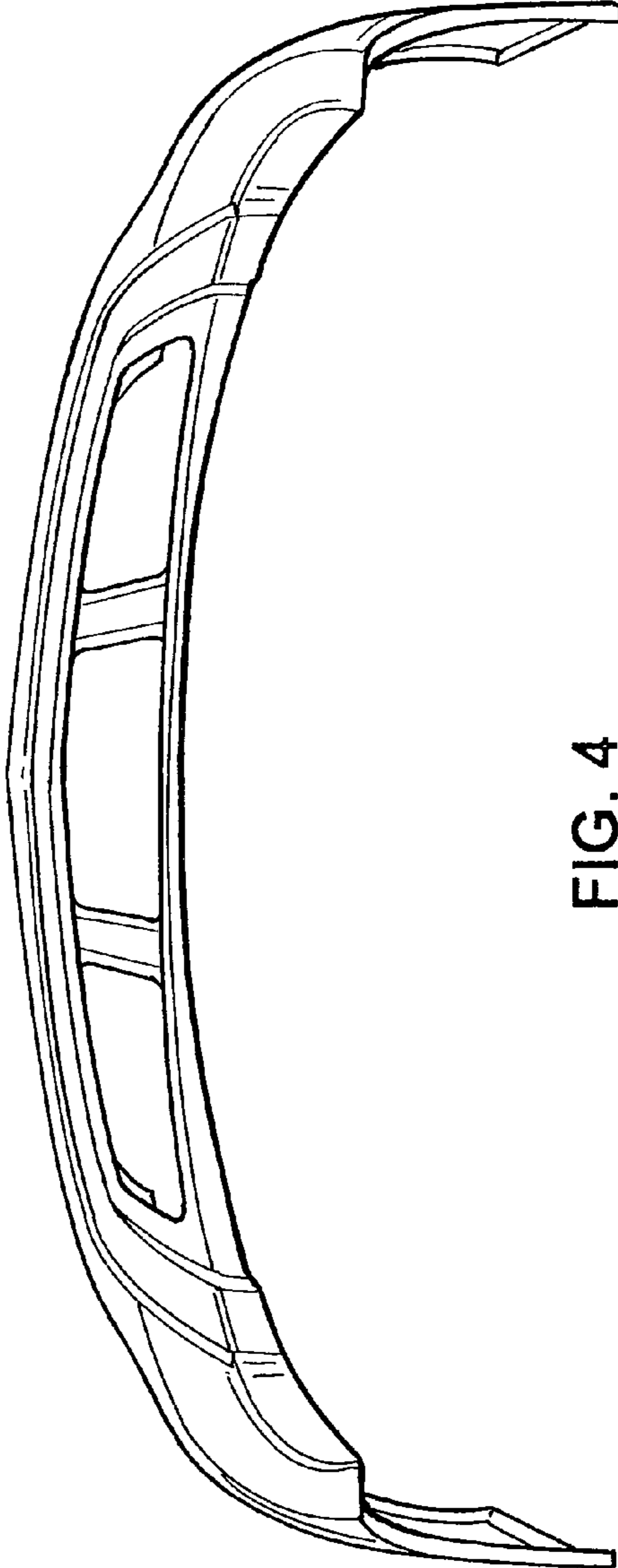

FIG. 4

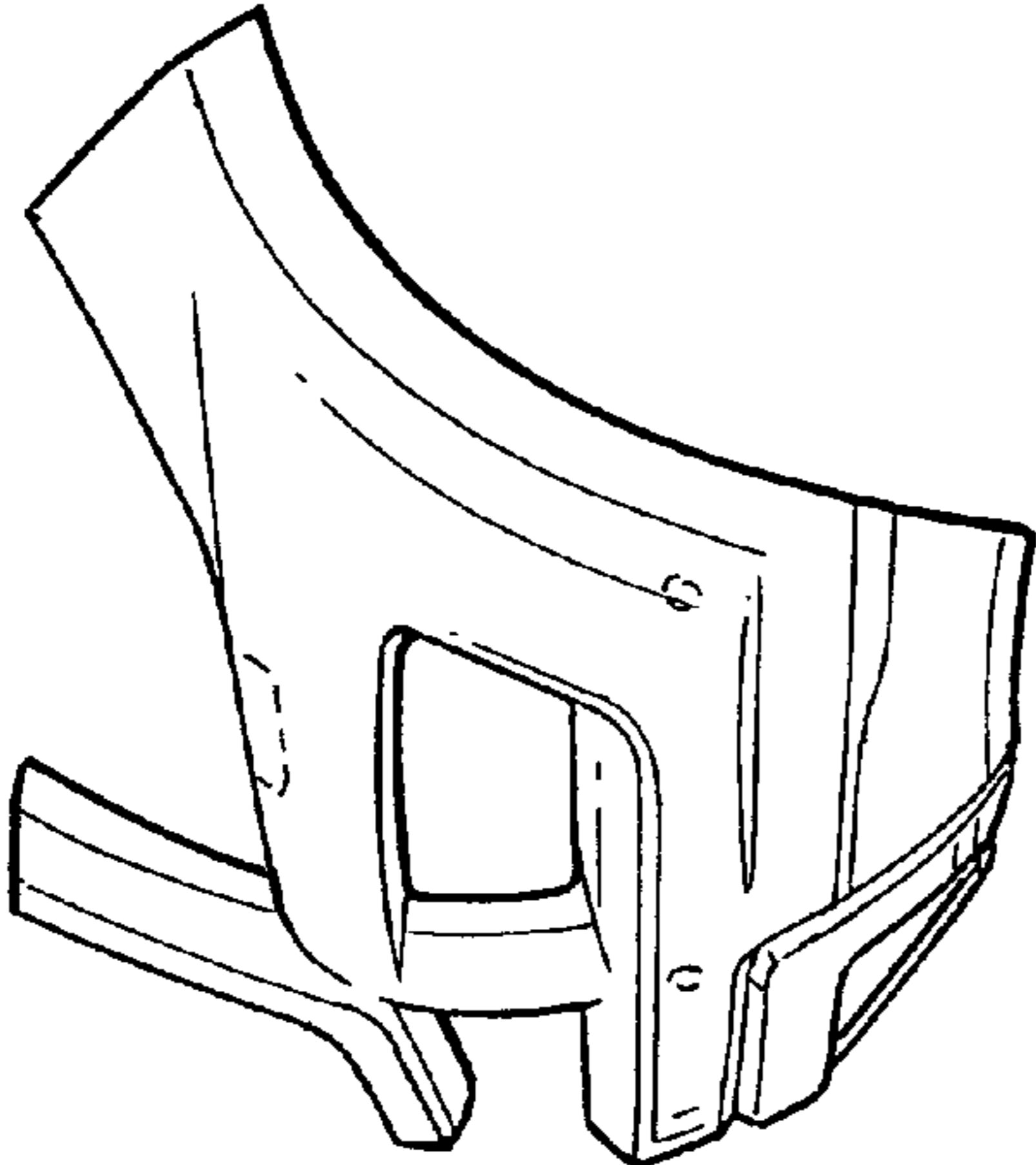

FIG. 5

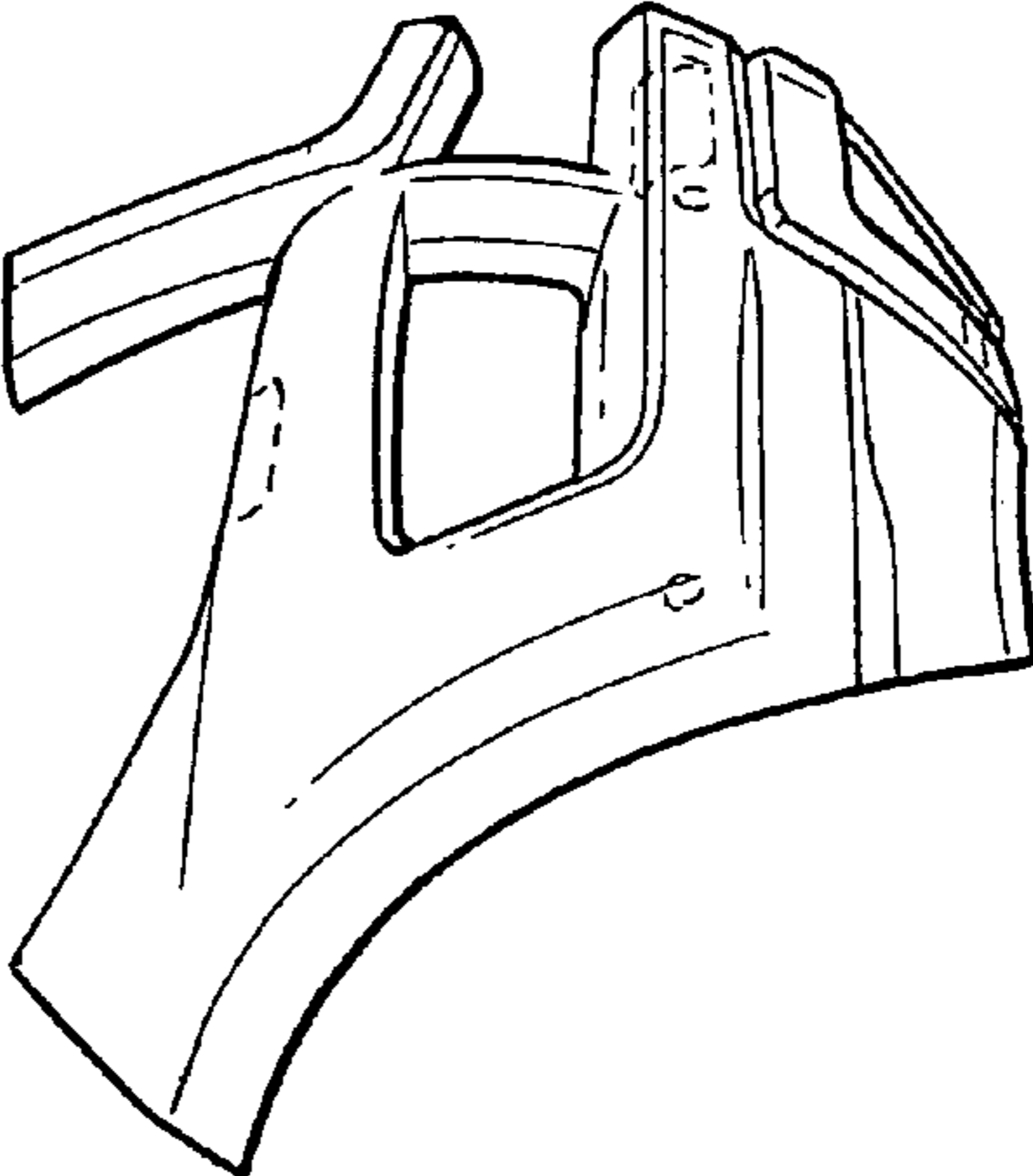

FIG. 6