



US00D670525S

(12) **United States Design Patent**  
**Fallon et al.**

(10) **Patent No.:** **US D670,525 S**  
(45) **Date of Patent:** **\*\* Nov. 13, 2012**

(54) **VESSEL**

(75) Inventors: **Barry Fallon**, Birmingham (GB); **Paul Hanniffy**, Birmingham (GB)

(73) Assignee: **Manitowoc Beverage Systems Ltd**,  
West Midlands (GB)

(\*\*) Term: **14 Years**

(21) Appl. No.: **29/416,578**

(22) Filed: **Mar. 23, 2012**

**Related U.S. Application Data**

(62) Division of application No. 29/356,558, filed on Feb. 26, 2010, now Pat. No. Des. 658,922.

(51) **LOC (9) Cl.** ..... **31-00**

(52) **U.S. Cl.** ..... **D7/300; D7/509**

(58) **Field of Classification Search** ..... D7/300,  
D7/306, 311, 317, 387, 605, 510, 305, 624.1;  
D9/716, 719, 515, 500, 549, 502, 504, 509,  
D9/529; 220/592.16, 592.17, 592.24, 737,  
220/718, 739, 715, 288; 215/12.1; 219/387,  
219/429; 229/403, 738, 739; 206/459.1;  
222/153.07, 542, 146.6, 608; 62/400; D3/202  
See application file for complete search history.

(56) **References Cited**

**U.S. PATENT DOCUMENTS**

D205,825 S	9/1966	Cornelius	
D229,530 S	12/1973	Simpson	
D242,834 S	12/1976	Little	
D272,308 S	1/1984	Schessel	
D298,719 S *	11/1988	Beckerer, Jr.	D7/624.2
D303,199 S *	9/1989	Parsons	D7/624.1

5,174,534 A *	12/1992	Mitchell	248/311.2
D332,891 S *	2/1993	Cumberland	D7/619.1
5,655,742 A *	8/1997	Whitman et al.	248/311.2
5,897,840 A *	4/1999	Owens et al.	422/559
D435,906 S	1/2001	Wilkinson et al.	
6,810,788 B2 *	11/2004	Hale	99/295
D513,939 S	1/2006	Leonzo	
D560,873 S	1/2008	Brans	

(Continued)

*Primary Examiner* — Cynthia Underwood

(74) *Attorney, Agent, or Firm* — Ohlandt, Greeley, Ruggiero & Perle, L.L.P.

(57) **CLAIM**

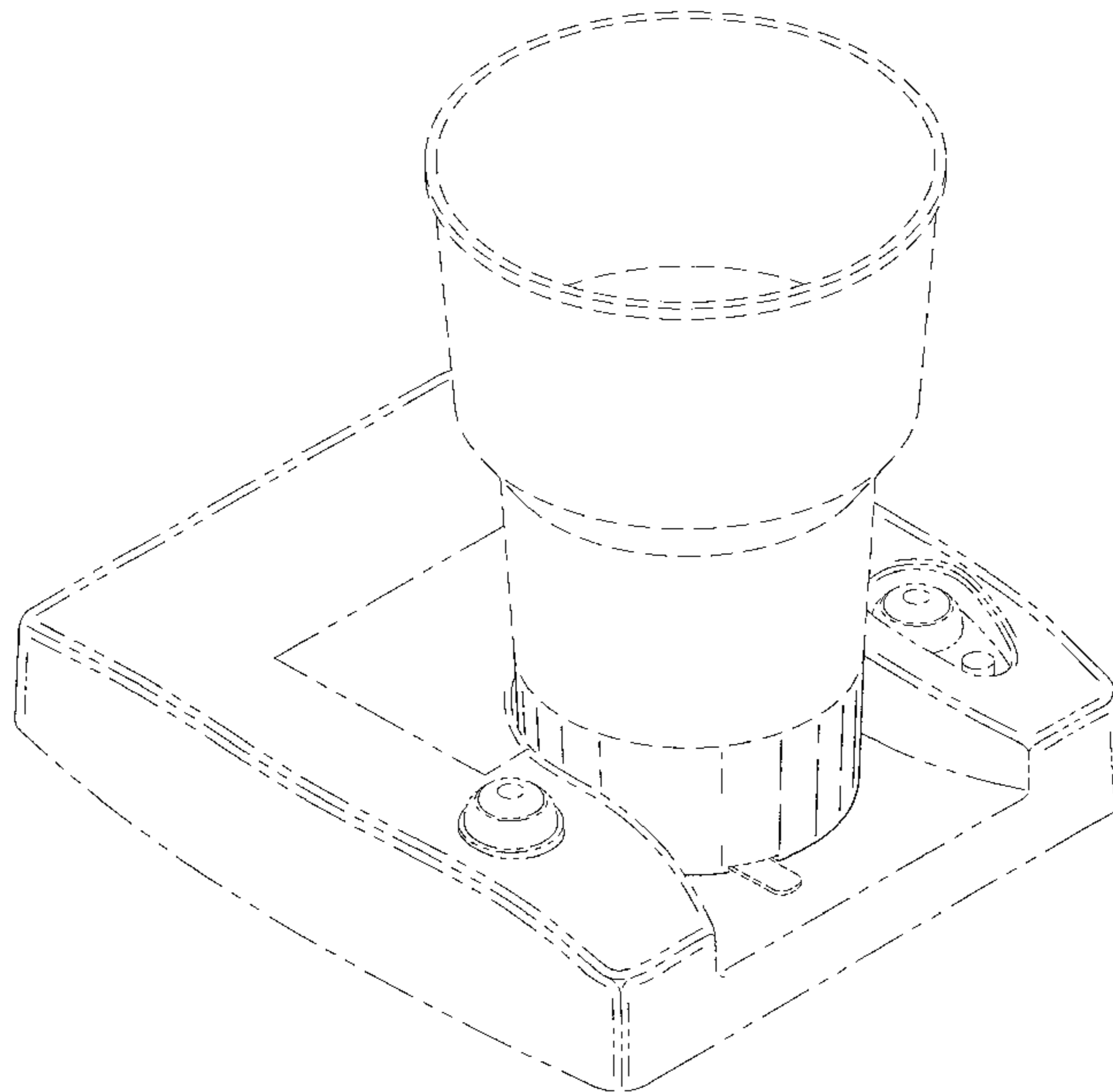
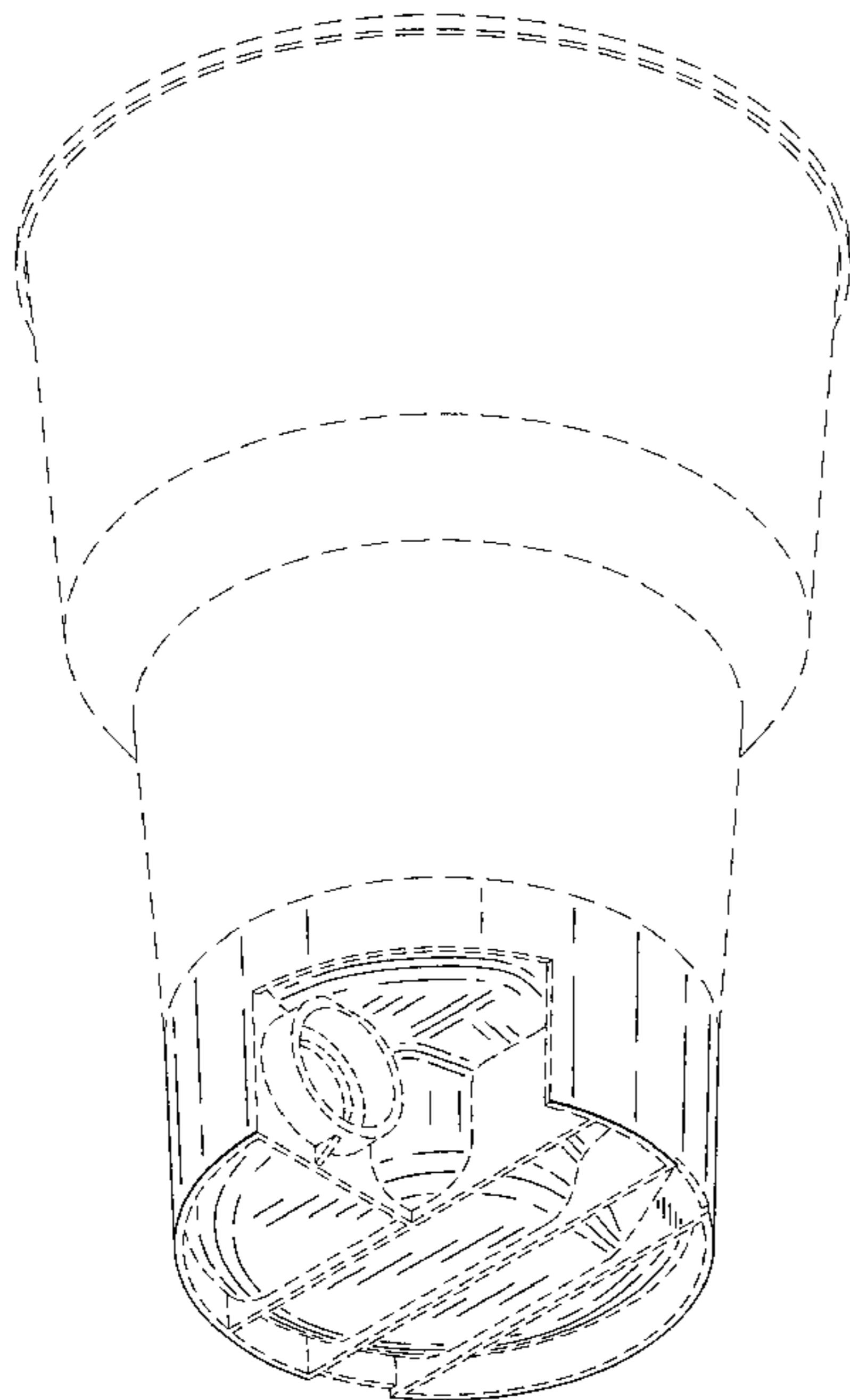
The ornamental design for a vessel, as shown and described.

**DESCRIPTION**

FIG. 1 is a top perspective view of a vessel of the present disclosure;  
 FIG. 2 is a bottom perspective view of the vessel of FIG. 1;  
 FIG. 3 is a first side view of the vessel of FIG. 1;  
 FIG. 4 is a second side view of the vessel of FIG. 1;  
 FIG. 5 is a third side view of the vessel of FIG. 1;  
 FIG. 6 is a fourth side view of the vessel of FIG. 1;  
 FIG. 7 is a top view of the vessel of FIG. 1;  
 FIG. 8 is a bottom view of the vessel of FIG. 1;  
 FIG. 9 is a front view of a cross section taken along line 9-9 of the vessel of FIG. 7;  
 FIG. 10 is a perspective view of a cross section taken along line 10-10 of the vessel of FIG. 7; and,  
 FIG. 11 is a perspective view of the vessel of FIG. 1 shown in use.

The broken lines in the drawings illustrate either environment structure or boundaries of the claim are for illustrative purposes only and form no part of the claim.

**1 Claim, 10 Drawing Sheets**



# US D670,525 S

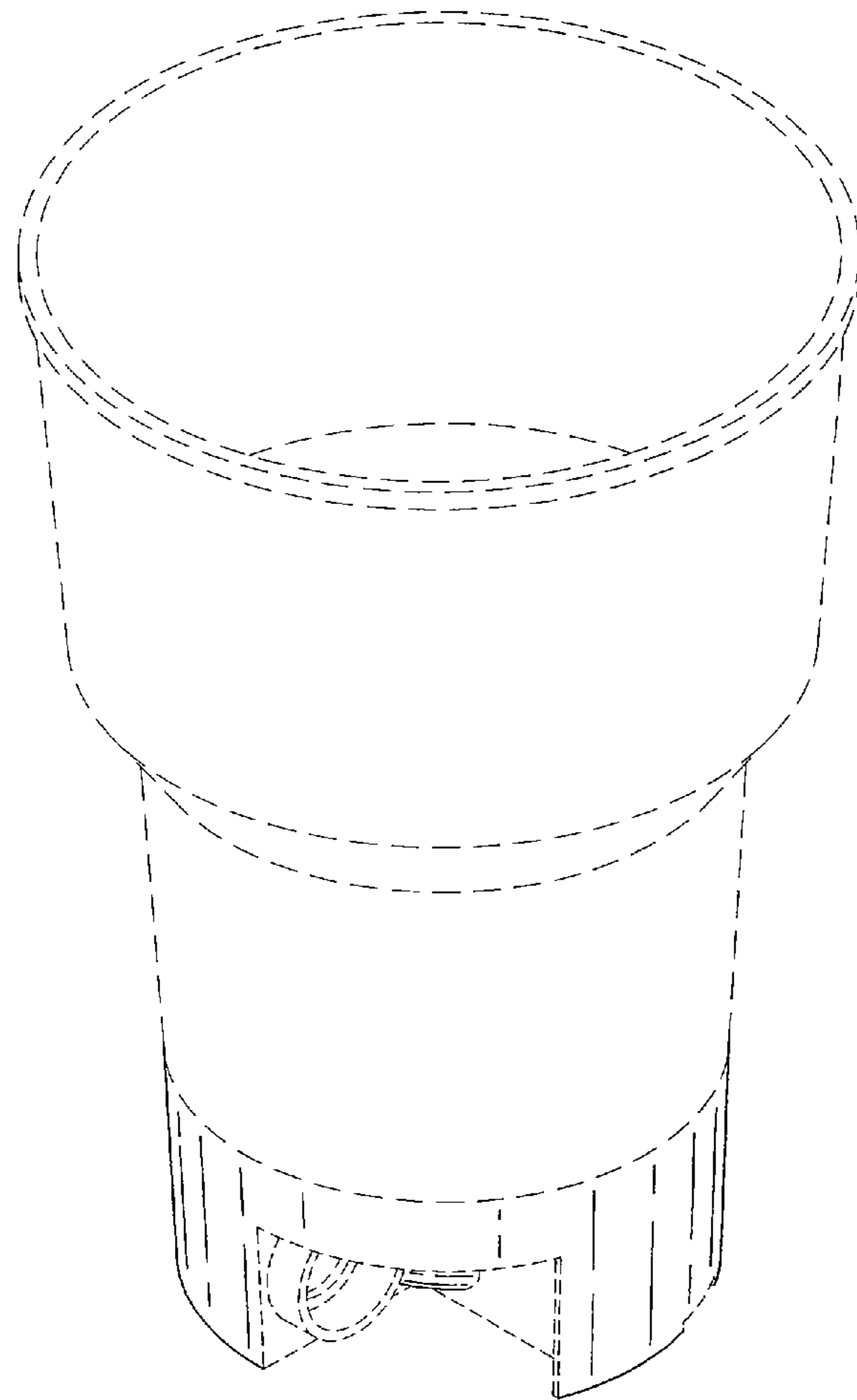
Page 2

---

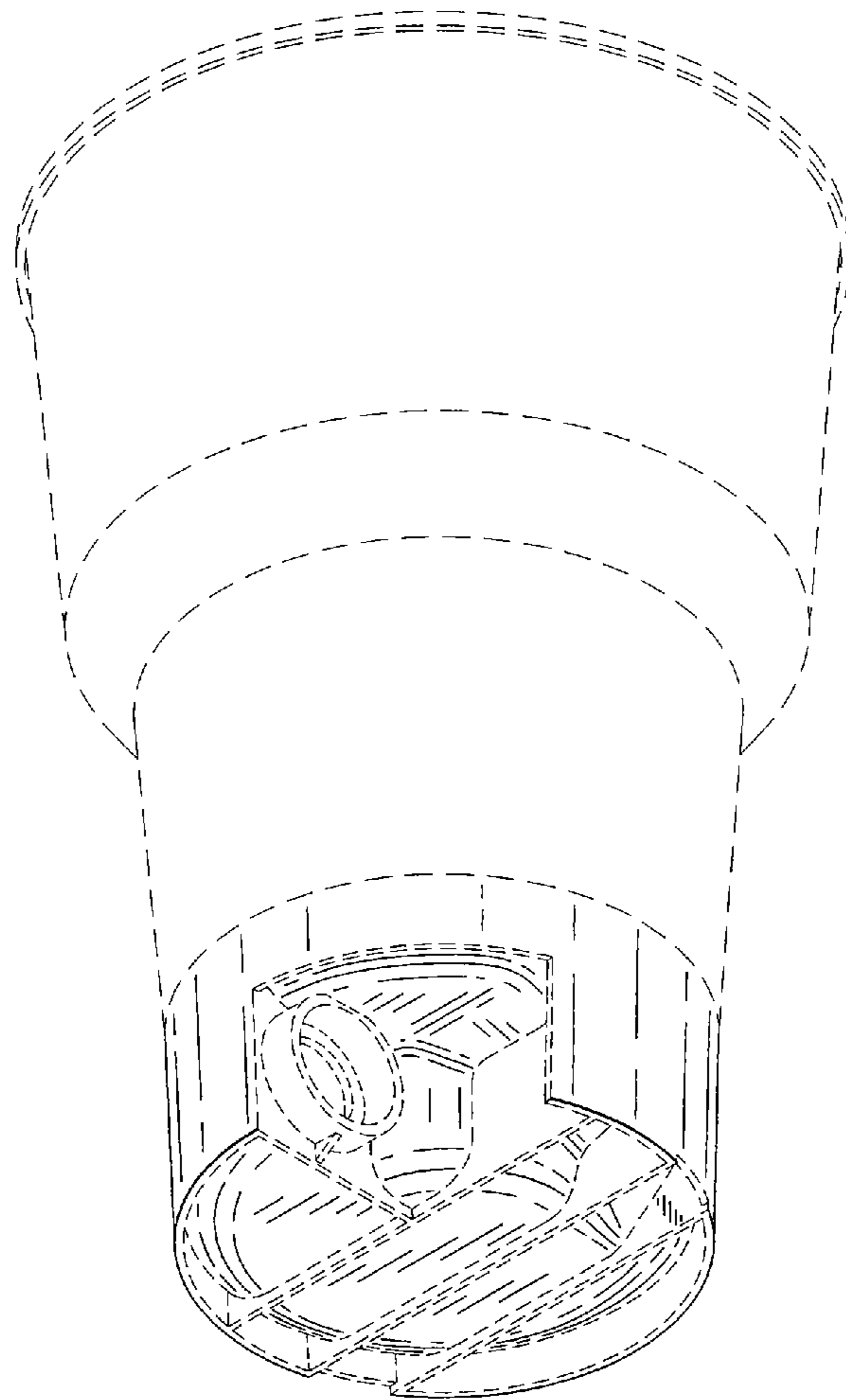
## U.S. PATENT DOCUMENTS

D567,021 S	4/2008	Bach et al.		D605,894 S *	12/2009	Drennow .....	D7/397
D578,348 S *	10/2008	Liu .....	D7/396.6	7,753,226 B2 *	7/2010	Chauvin .....	220/714
D581,737 S *	12/2008	Starck .....	D7/509	D634,167 S	3/2011	Foster	
D587,524 S	3/2009	Allen et al.		D637,442 S	5/2011	Fallon et al.	
D595,539 S	7/2009	Starck		D643,734 S *	8/2011	Perez et al. ....	D9/548
D597,679 S *	8/2009	Shigesada et al. ....	D24/216				

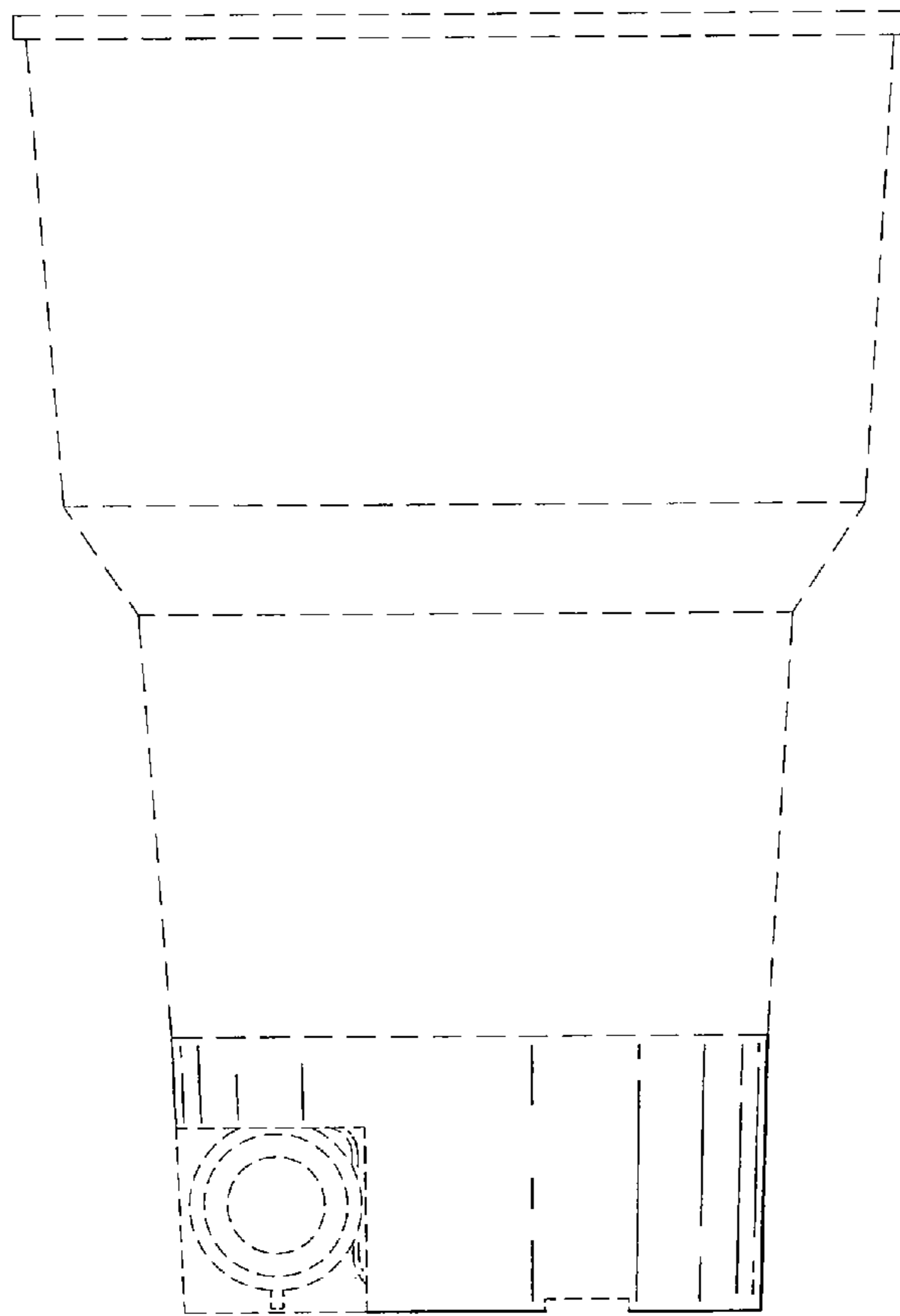
\* cited by examiner



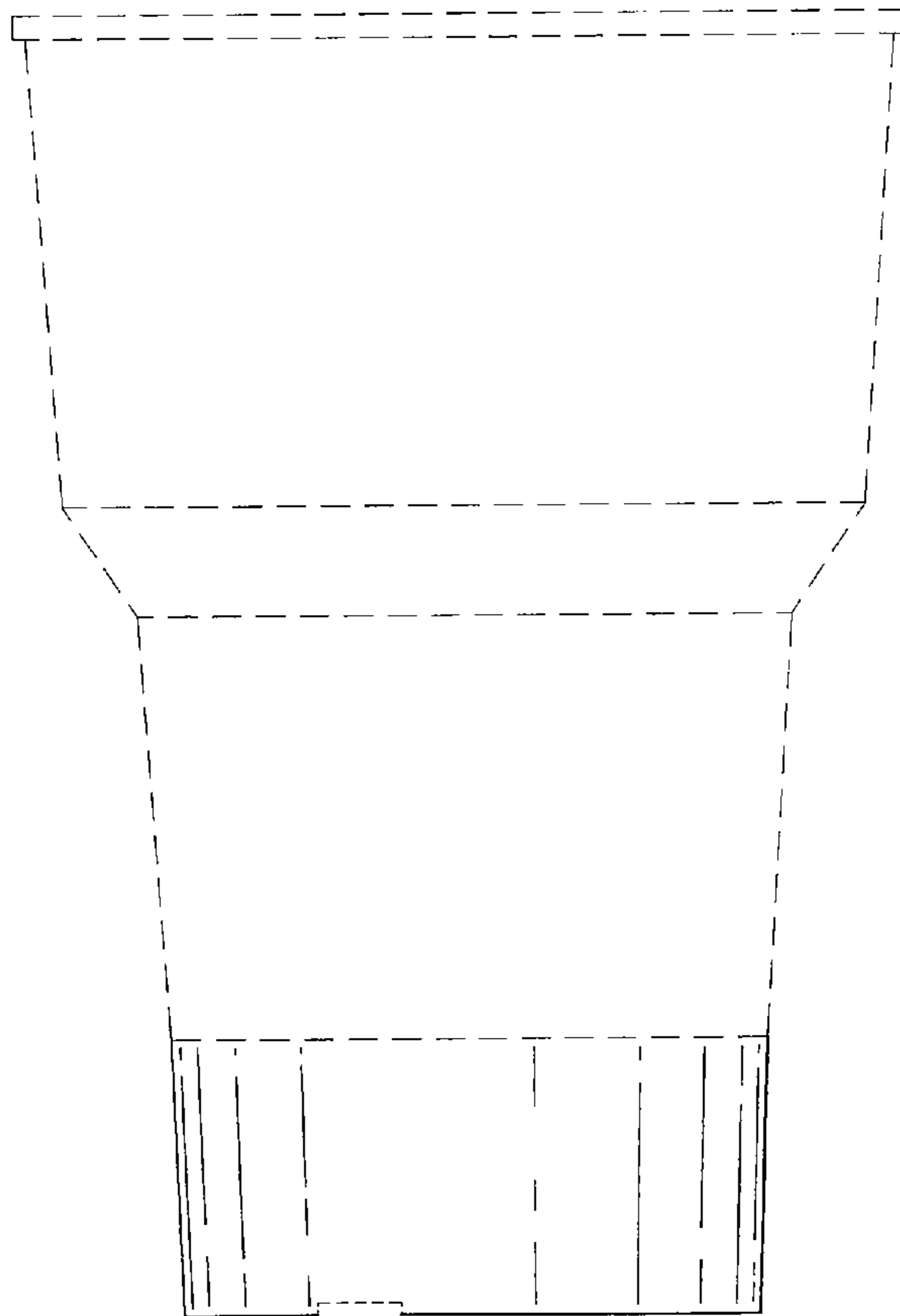
**FIG. 1**



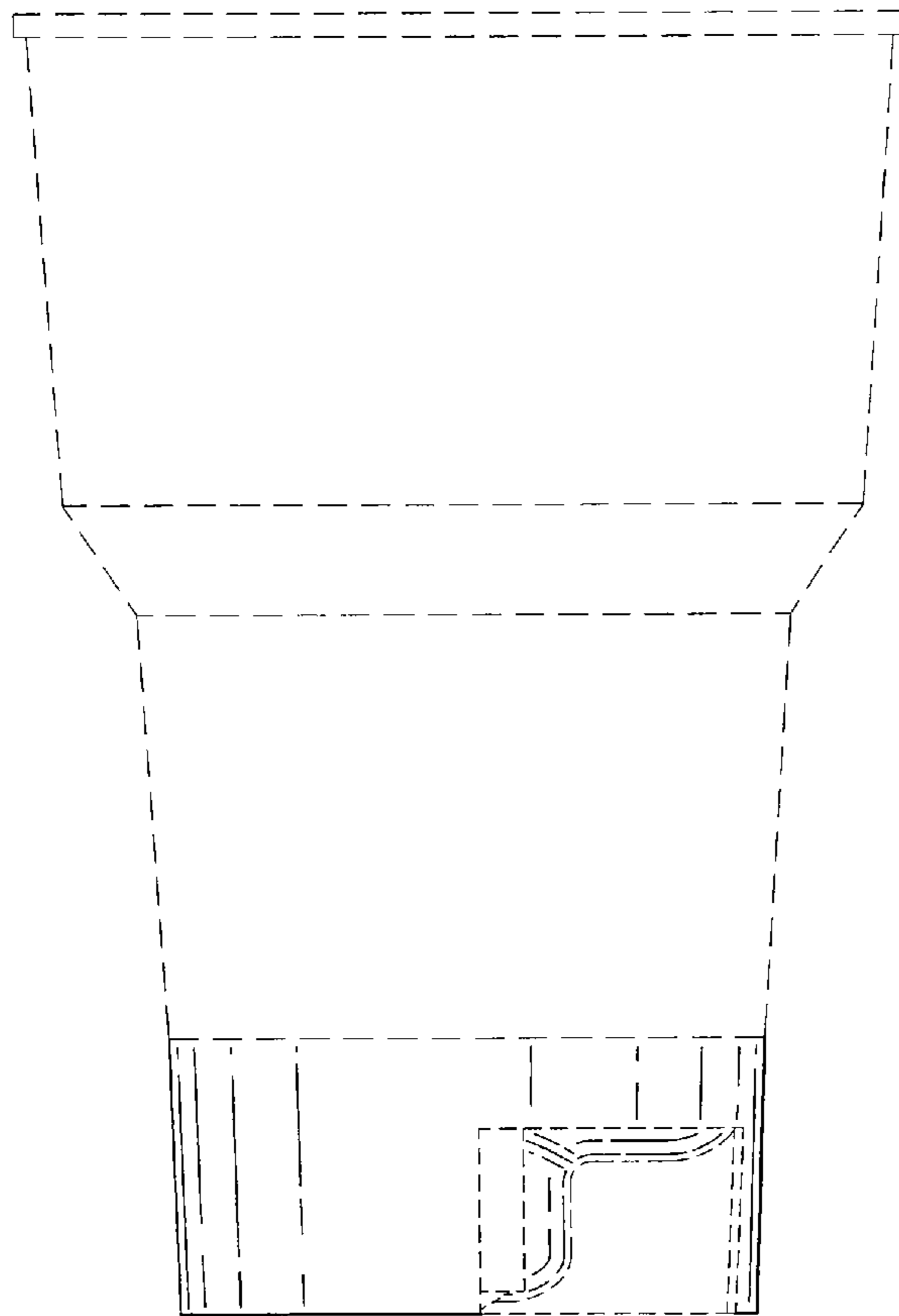
**FIG. 2**



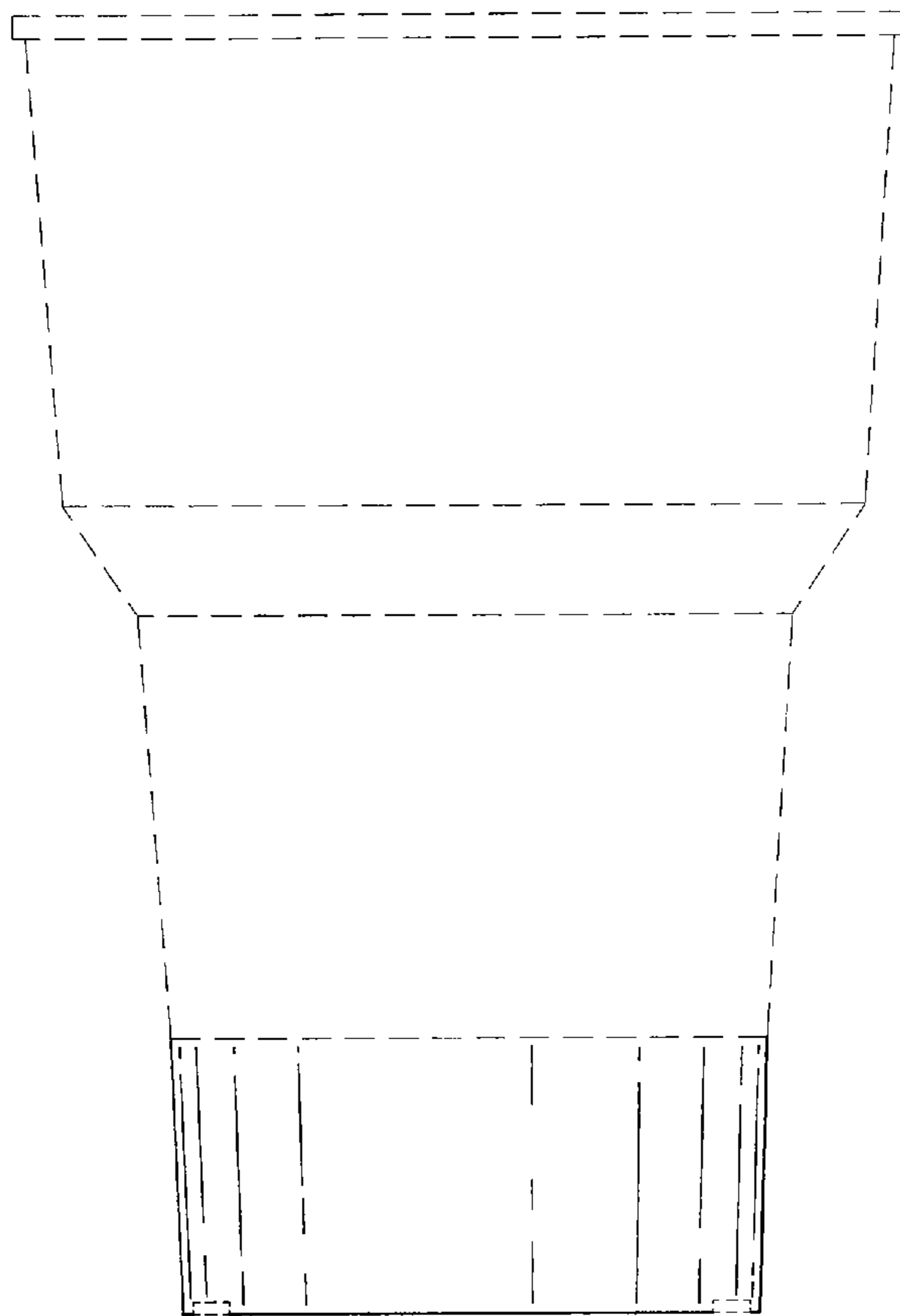
**FIG. 3**



**FIG. 4**

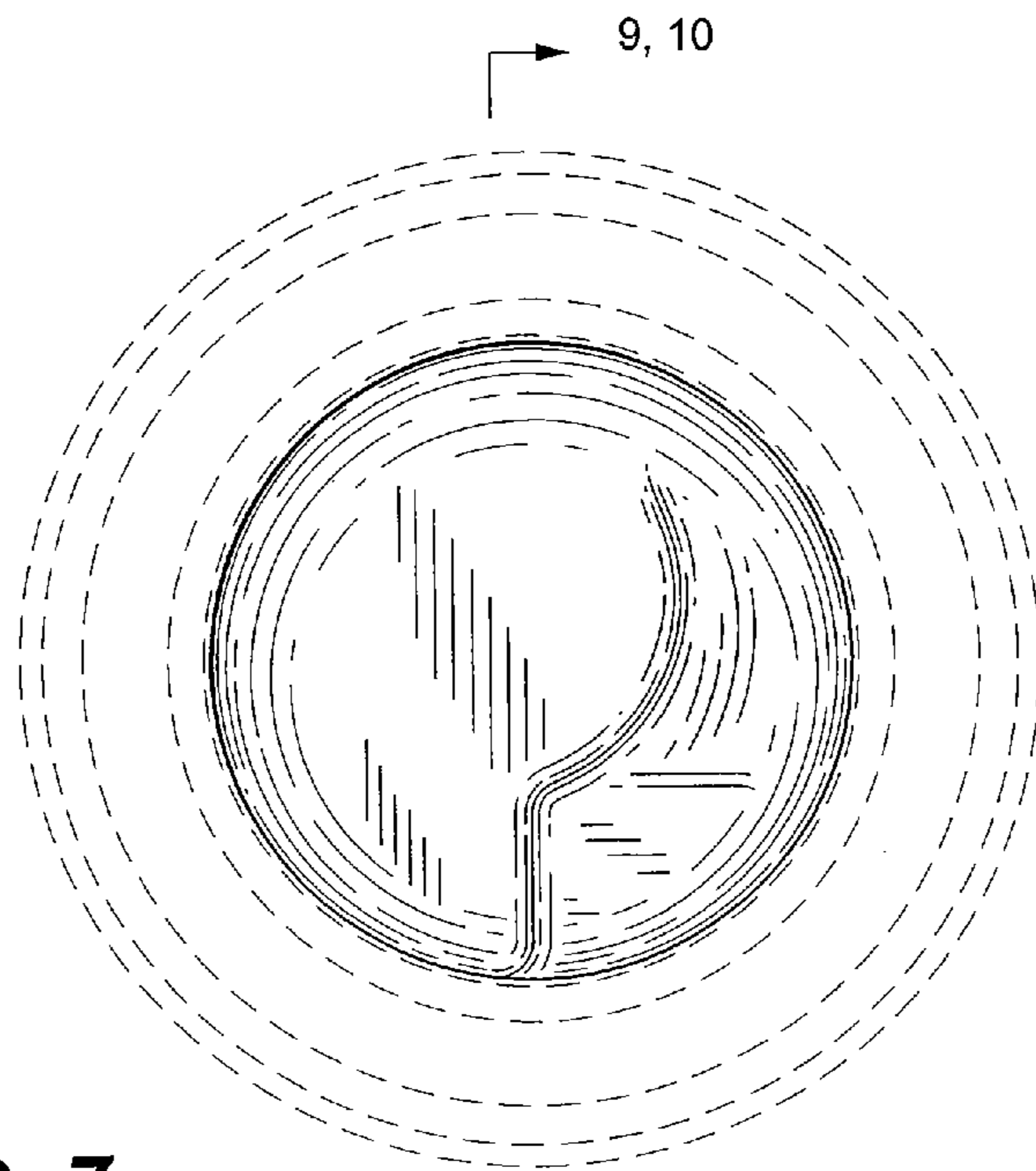


**FIG. 5**

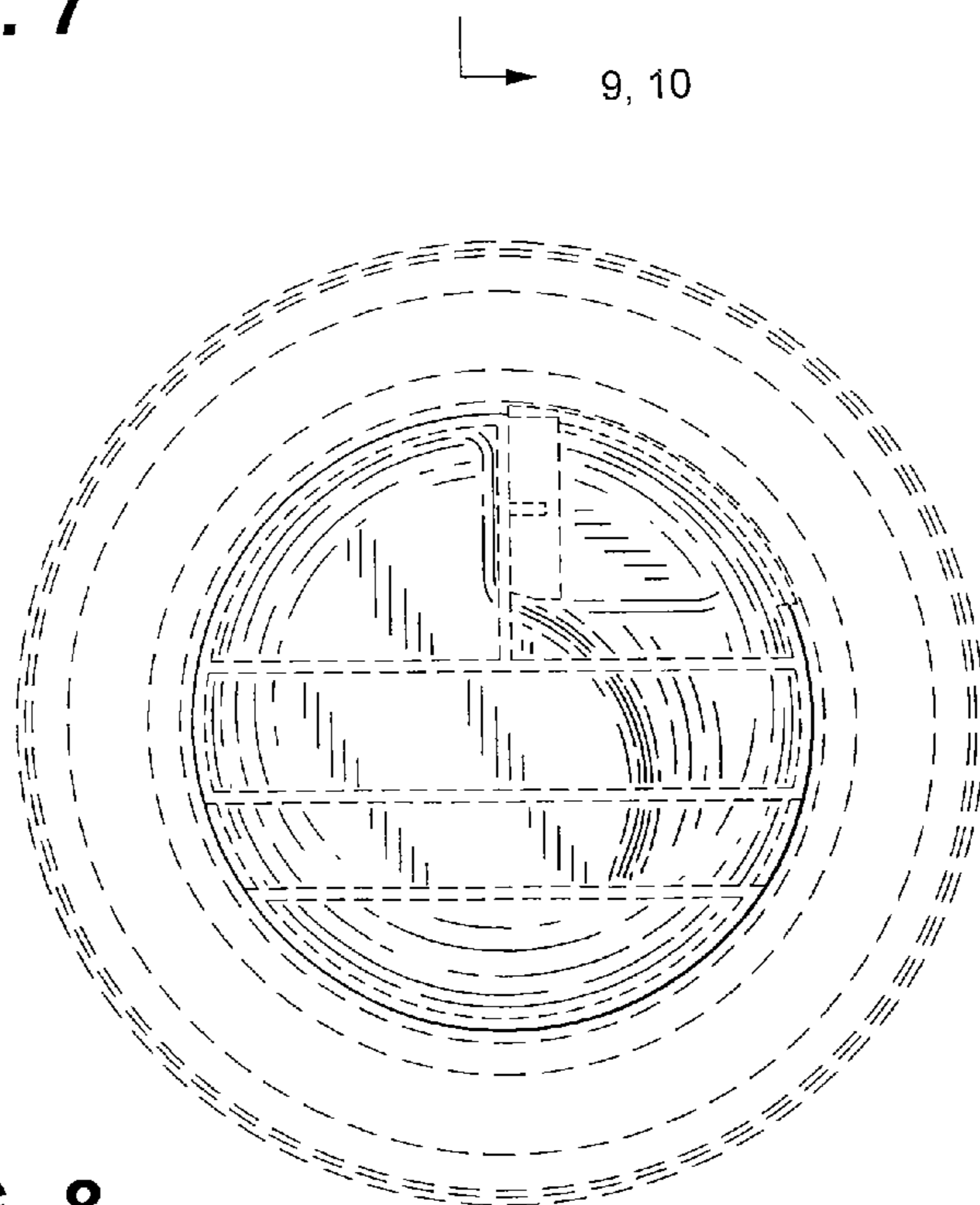


**FIG. 6**

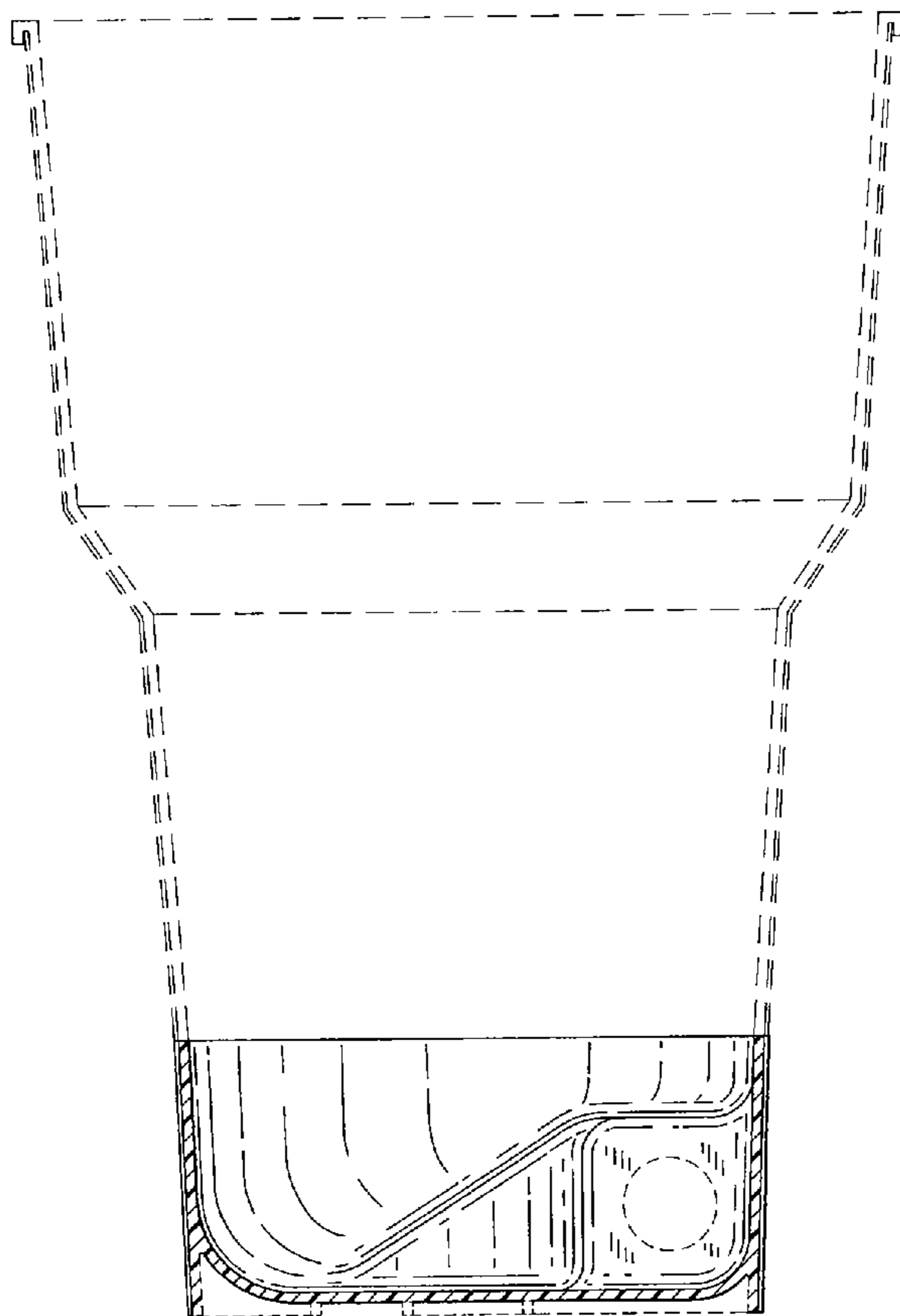




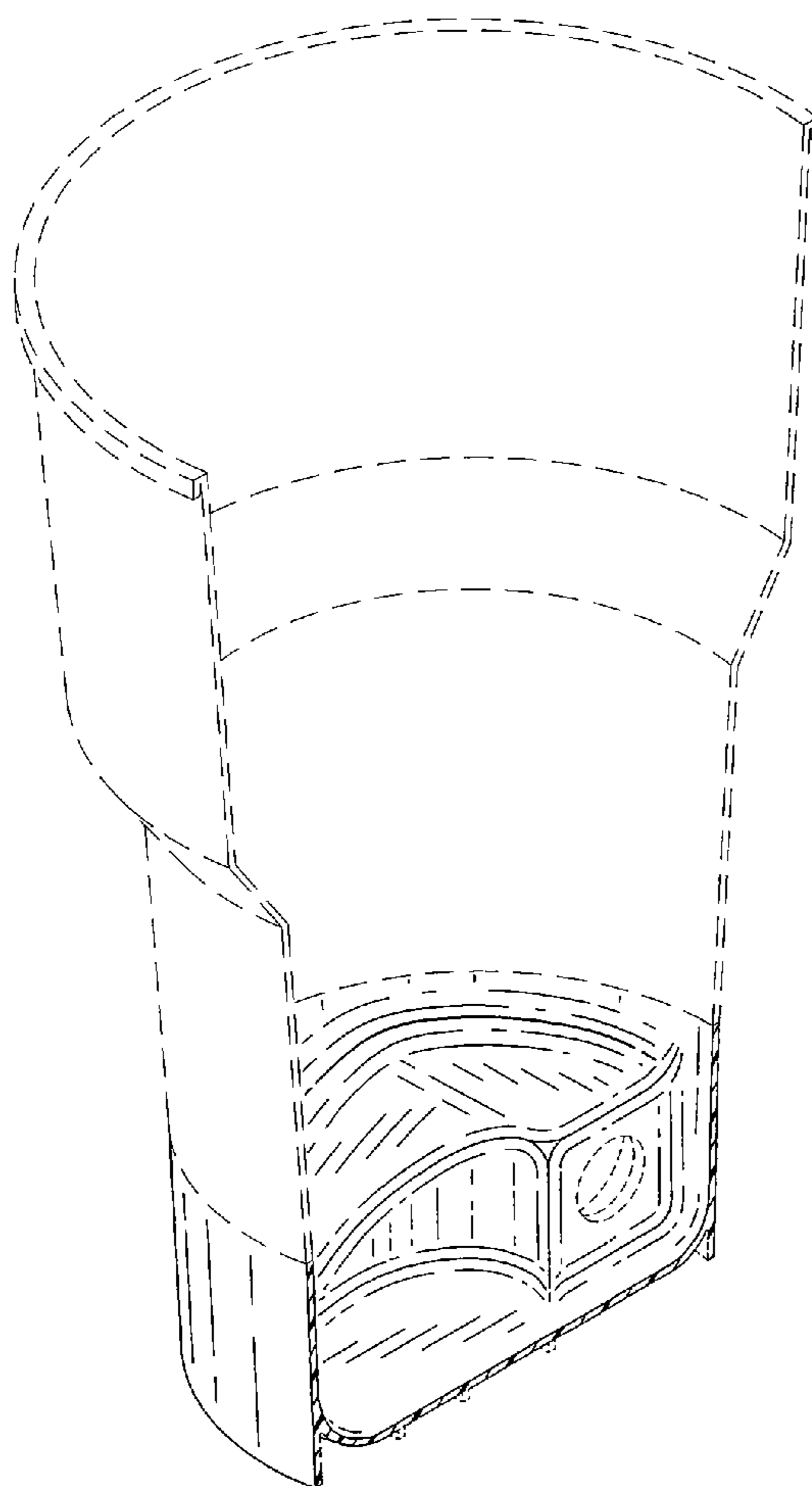
**FIG. 7**



**FIG. 8**



**FIG. 9**



**FIG. 10**

**FIG. 11**

