



US00D670394S

(12) **United States Design Patent**
Collins

(10) **Patent No.:** **US D670,394 S**
(45) **Date of Patent:** **** Nov. 6, 2012**

(54) **HOUSING FOR INSTRUMENT FOR TAKING HEALTH-RELATED MEASUREMENTS**

(76) Inventor: **John Collins**, Monrovia, CA (US)

(**) Term: **14 Years**

(21) Appl. No.: **29/382,378**

(22) Filed: **Jan. 3, 2011**

(51) **LOC (9) Cl.** **24-01**

(52) **U.S. Cl.** **D24/186**

(58) **Field of Classification Search** D24/107,
D24/111, 164–165, 186, 167, 216, 231; 600/301,
600/481, 483–485, 509, 513, 519, 544; D10/81,
D10/104

See application file for complete search history.

(56) **References Cited**

U.S. PATENT DOCUMENTS

D435,904 S *	1/2001	Naude	D24/200
D475,137 S *	5/2003	Manke et al.	D24/165
D536,794 S *	2/2007	Knieriem et al.	D24/186
D536,795 S *	2/2007	Knieriem et al.	D24/186
D550,366 S *	9/2007	Zhou et al.	D24/186
D554,263 S *	10/2007	Al-Ali et al.	D24/186
D562,456 S *	2/2008	Scruggs et al.	D24/160
D600,814 S *	9/2009	Lathrop et al.	D24/186
D613,411 S *	4/2010	Collins et al.	D24/186
D621,511 S *	8/2010	Lathrop et al.	D24/167

D624,654 S *	9/2010	Shimizu	D24/186
D634,435 S *	3/2011	Chua et al.	D24/186
D641,881 S *	7/2011	Inami et al.	D24/165
D643,126 S *	8/2011	Barker et al.	D24/186

* cited by examiner

Primary Examiner — T. Chase Nelson

Assistant Examiner — Mark Cavanna

(74) *Attorney, Agent, or Firm* — Wood, Phillips, Katz, Clark & Mortimer

(57) **CLAIM**

The ornamental design for a housing for instrument for taking health-related measurements, as shown and described.

DESCRIPTION

FIG. 1 is a front, right, and top perspective view of a housing for instrument for taking health-related measurements showing my/our new design;

FIG. 2 is a rear elevational view thereof;

FIG. 3 is a front elevational view thereof;

FIG. 4 is a top view thereof;

FIG. 5 is a bottom view thereof;

FIG. 6 is a right side elevational view; and,

FIG. 7 is a left side elevational view.

The portions of the housing for instrument for taking health-related measurements shown in dotted lines do not constitute a part of the claimed design.

1 Claim, 4 Drawing Sheets

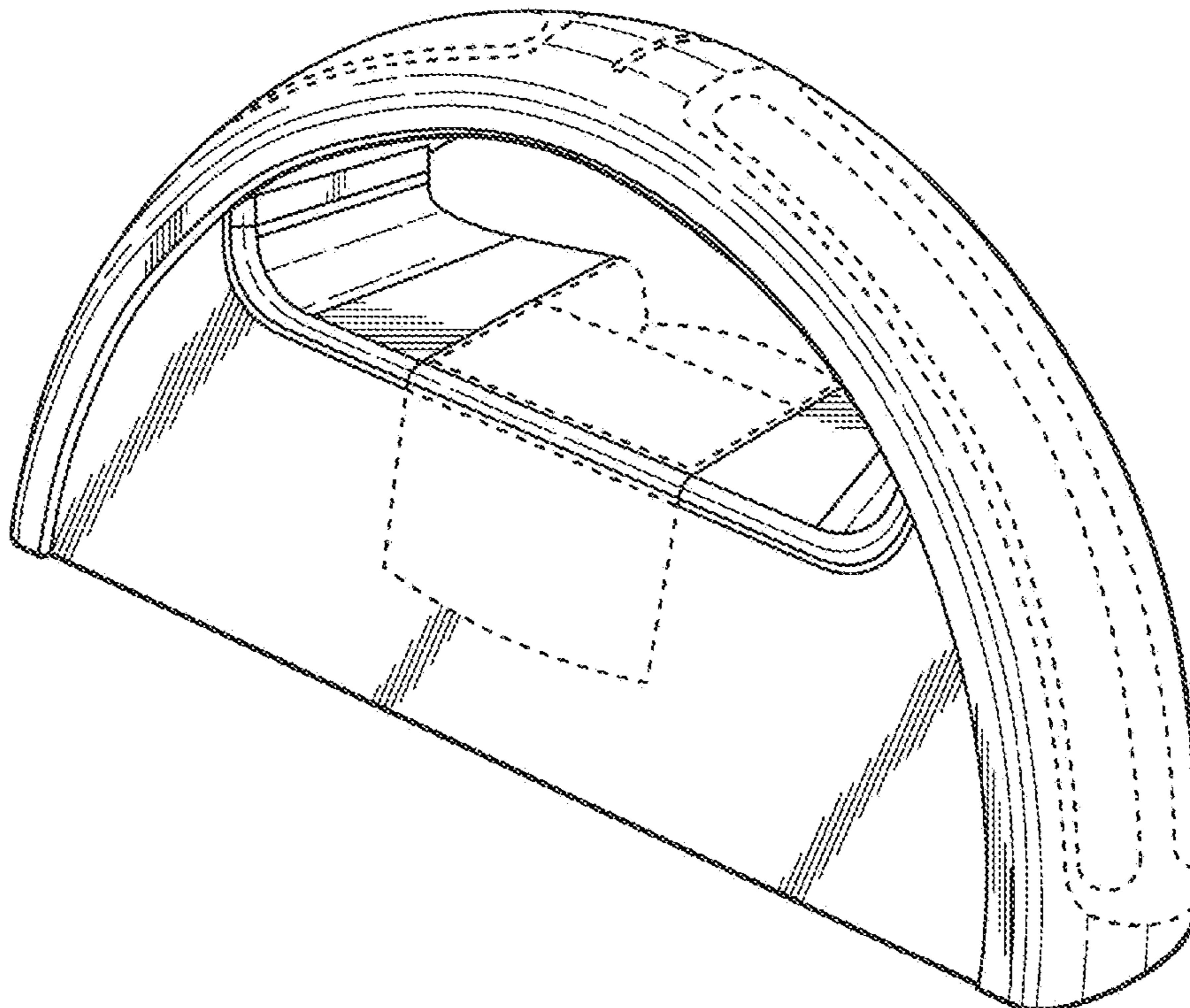

Fig. 1

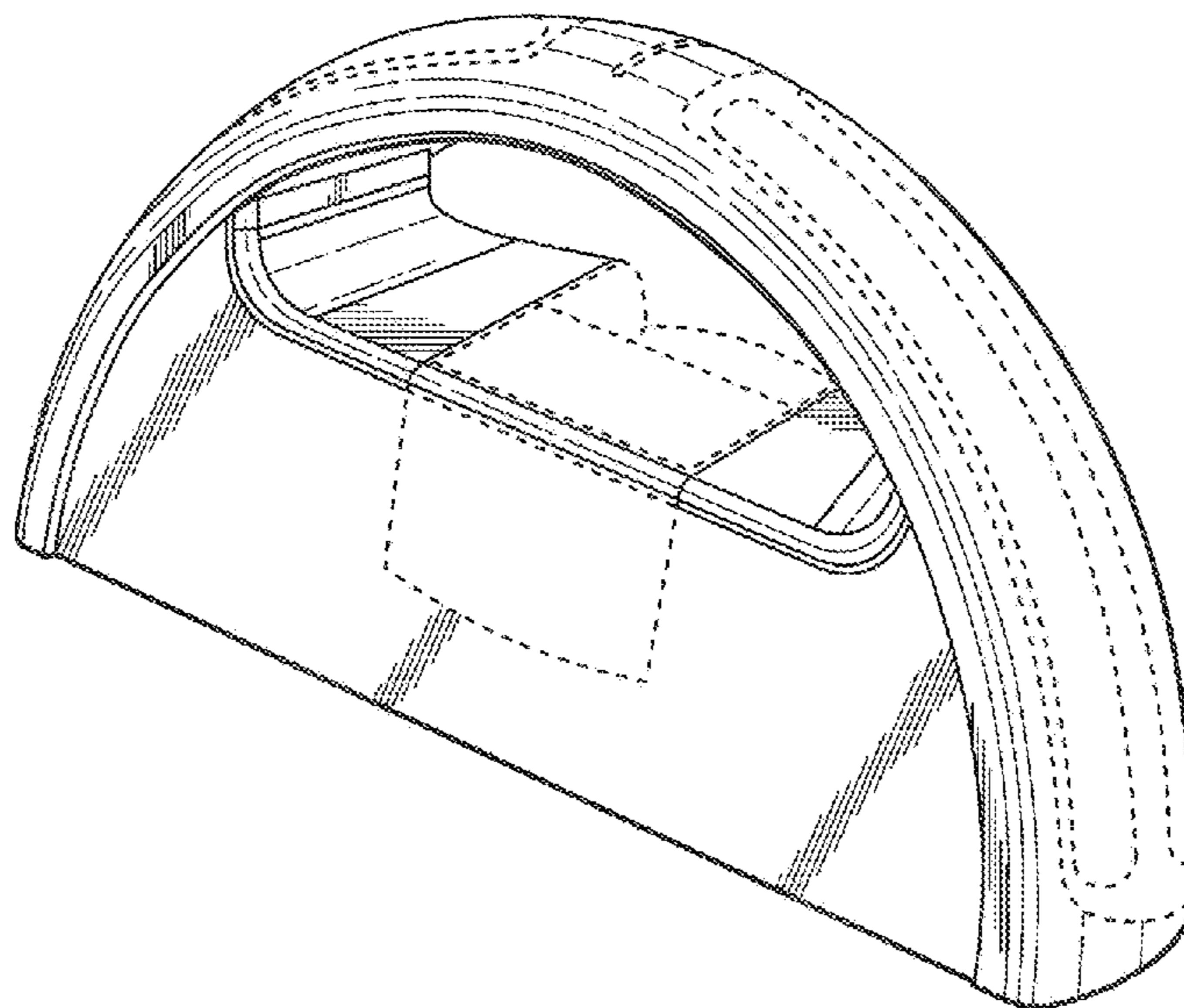

Fig. 2

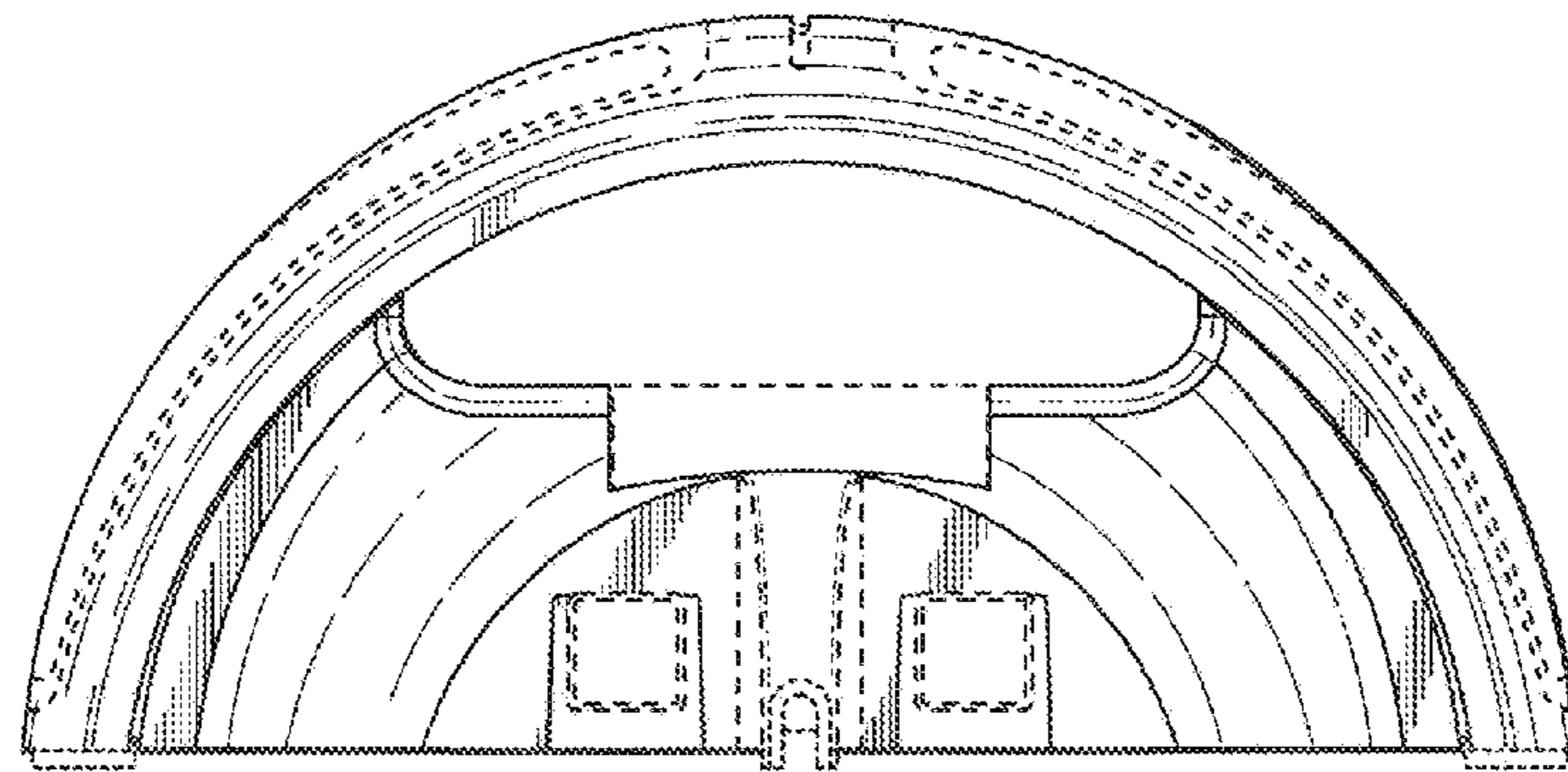

Fig. 3

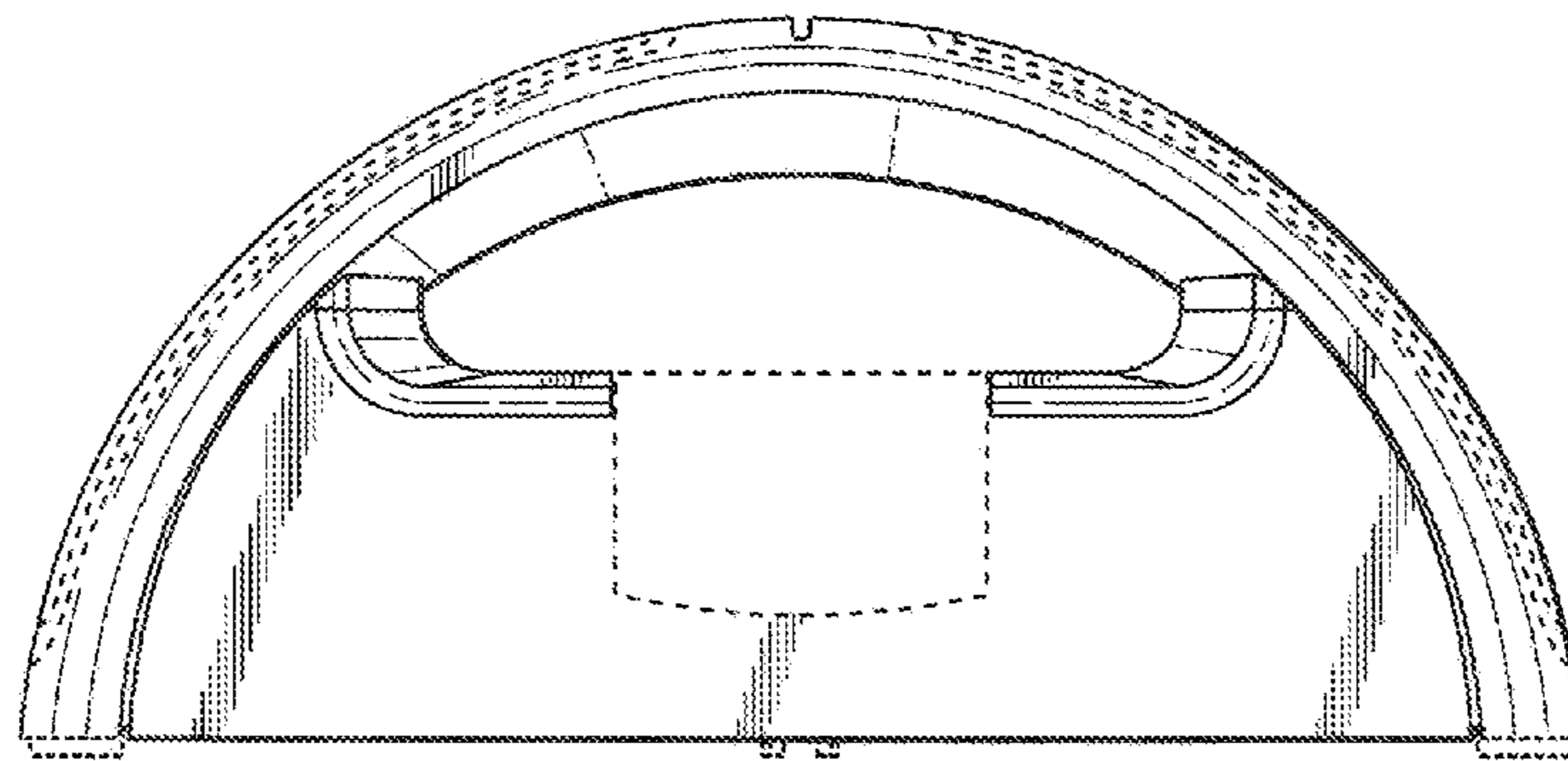

Fig. 4

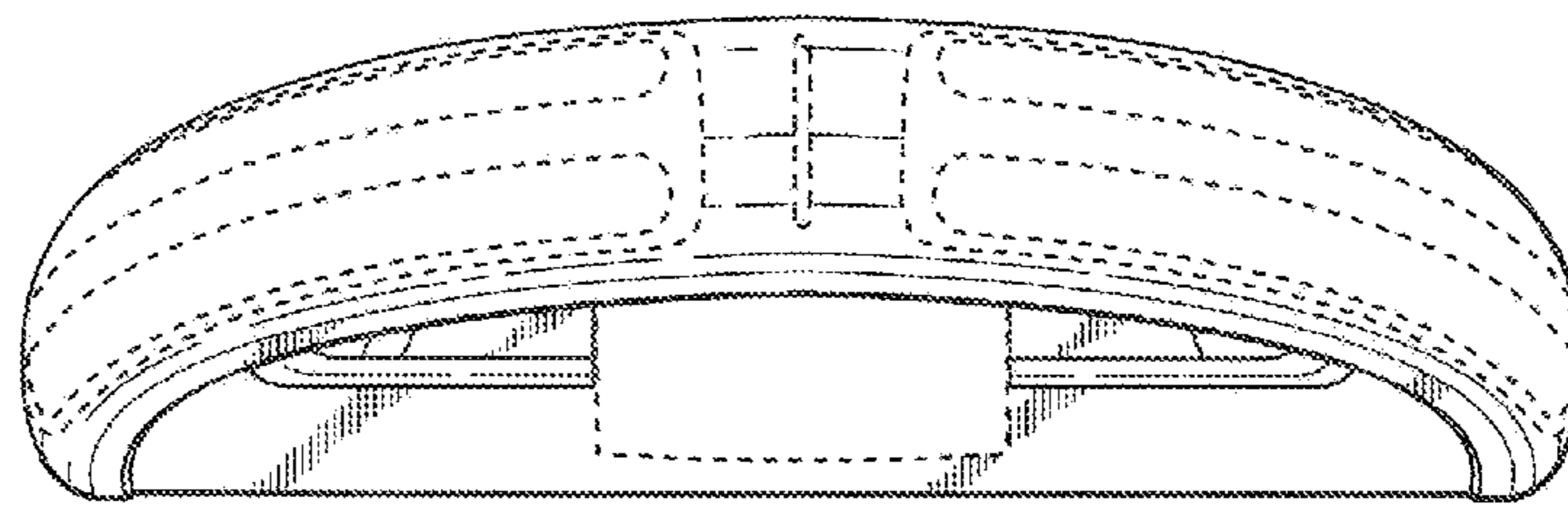

Fig. 5

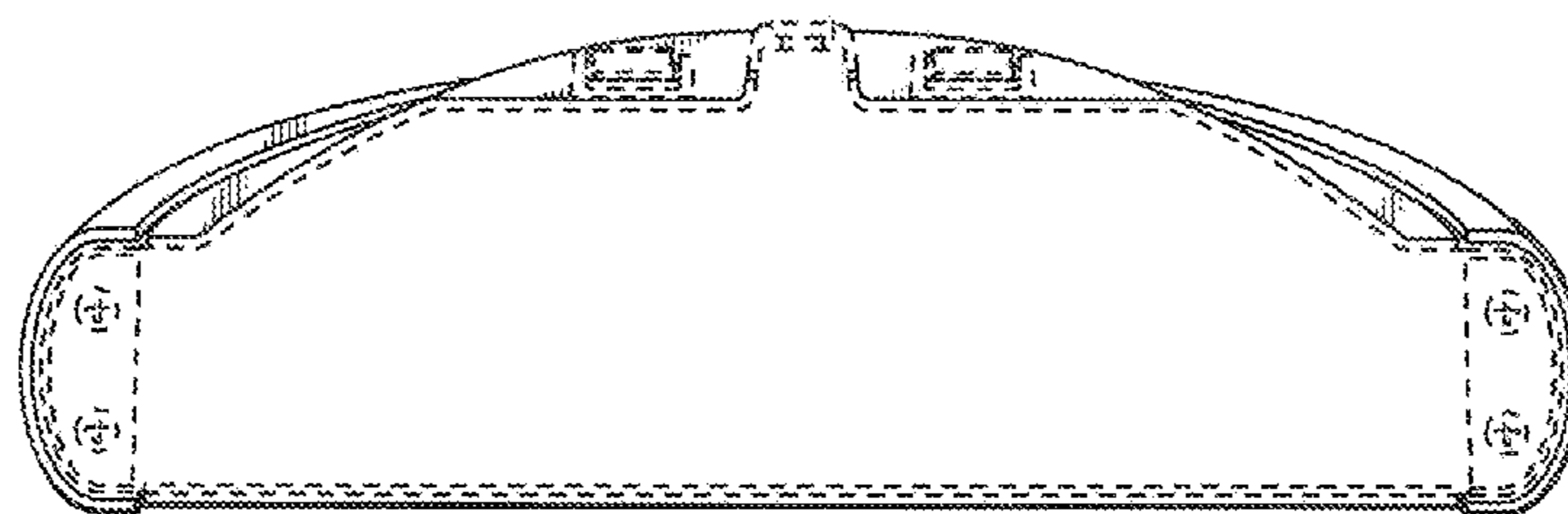

Fig. 6

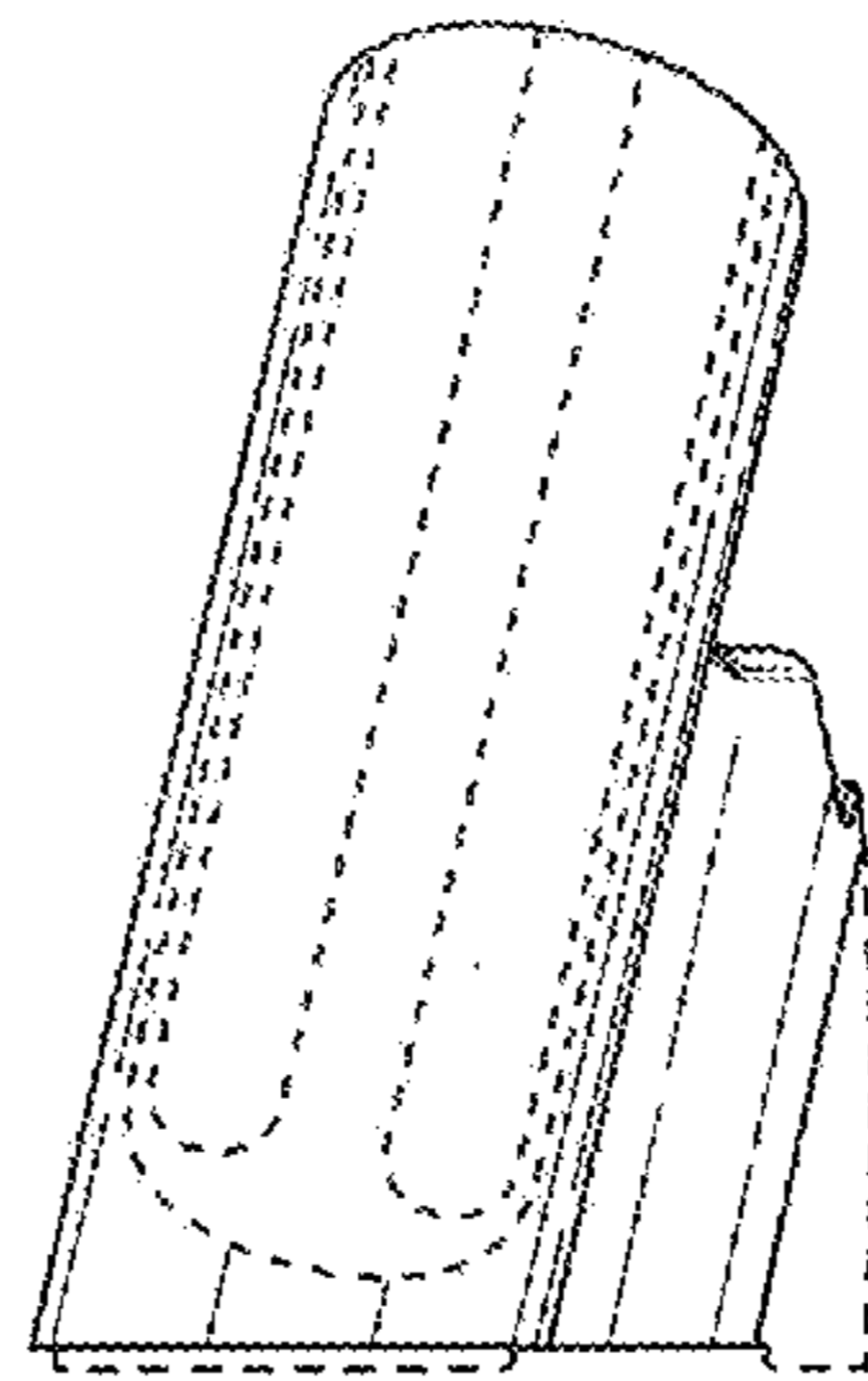

Fig. 7

