



US00D670218S

(12) **United States Design Patent**
Bobba et al.

(10) **Patent No.:** **US D670,218 S**
(45) **Date of Patent:** **** Nov. 6, 2012**

(54) **ENERGY ABSORBER FOR A VEHICLE BUMPER UNIT**

(75) Inventors: **Somasekhar Venkat Bobba**, Bangalore (IN); **Dhanendra Kumar Nagwanshi**, Bangalore (IN); **Matthew D. Marks**, Waterford, MI (US)

(73) Assignee: **Sabic Innovative Plastics IP B.V.** (NL)

(**) Term: **14 Years**

(21) Appl. No.: **29/419,820**

(22) Filed: **May 2, 2012**

Related U.S. Application Data

(63) Continuation of application No. 13/288,298, filed on Nov. 3, 2011.

(51) **LOC (9) Cl.** **12-16**

(52) **U.S. Cl.** **D12/196; D12/169**

(58) **Field of Classification Search** D12/169, D12/196, 171, 216, 163, 86, 90-92; 293/102, 293/113, 115, 117, 120, 122, 109, 132, 133, 293/142, 143; 296/180.1, 180.2

See application file for complete search history.

(56) **References Cited**

U.S. PATENT DOCUMENTS

4,940,270	A	7/1990	Yamazaki et al.	
D431,506	S *	10/2000	Runfola	D12/169
D515,989	S *	2/2006	Choi et al.	D12/169
7,044,514	B2	5/2006	Mustafa et al.	
D580,319	S *	11/2008	Gueler et al.	D12/169
7,568,746	B2 *	8/2009	Jaarda et al.	293/132
D603,764	S *	11/2009	Youn	D12/169
D603,765	S *	11/2009	Youn	D12/169
D607,790	S *	1/2010	Golden et al.	D12/169
D607,791	S *	1/2010	Golden et al.	D12/169
7,690,703	B2 *	4/2010	Maruko	293/102
7,699,367	B2 *	4/2010	Evans et al.	293/120
D624,471	S *	9/2010	Green	D12/169
7,866,716	B2 *	1/2011	Perucca et al.	293/133
7,938,462	B2 *	5/2011	Nilsson	293/102
7,954,866	B2 *	6/2011	Barcomb et al.	293/143

8,087,706	B2 *	1/2012	Karlander et al.	293/102
8,096,595	B2 *	1/2012	Muskos	293/120
8,191,944	B2 *	6/2012	Rinklin	293/142
2002/0005644	A1	1/2002	Tamada et al.	
2004/0174025	A1	9/2004	Converse et al.	
2007/0200376	A1	8/2007	Jaarda et al.	
2009/0256370	A1	10/2009	Siler et al.	
2010/0326782	A1	12/2010	VandenBerge et al.	

FOREIGN PATENT DOCUMENTS

EP 1038733 A2 9/2000

OTHER PUBLICATIONS

European Enhanced Vehicle-Safety Committee; EEVC Working Group 17 Report, "Improved Test Methods to Evaluate Pedestrian Protection Afforded by Passenger Cars"; Dec. 1998; Updated Sep. 2002; 98 Pages.

* cited by examiner

Primary Examiner — Melody N Brown

(74) *Attorney, Agent, or Firm* — Cantor Colburn LLP

(57) **CLAIM**

We claim, the ornamental design for energy absorber for a vehicle bumper unit, as shown and described.

DESCRIPTION

FIG. 1 is a front perspective view of an energy absorber for a vehicle bumper unit, showing an embodiment of our new design;

FIG. 2 is a rear perspective view of the embodiment shown in FIG. 1;

FIG. 3 is a top plan view of the embodiment shown in FIG. 1;

FIG. 4 is a front elevation view of the embodiment shown in FIG. 1;

FIG. 5 is a bottom plan view of the embodiment shown in FIG. 1;

FIG. 6 is a rear elevation view of the embodiment shown in FIG. 1;

FIG. 7 is a left elevation view of the embodiment shown in FIG. 1; and

FIG. 8 is a right elevation view of the embodiment shown in FIG. 1.

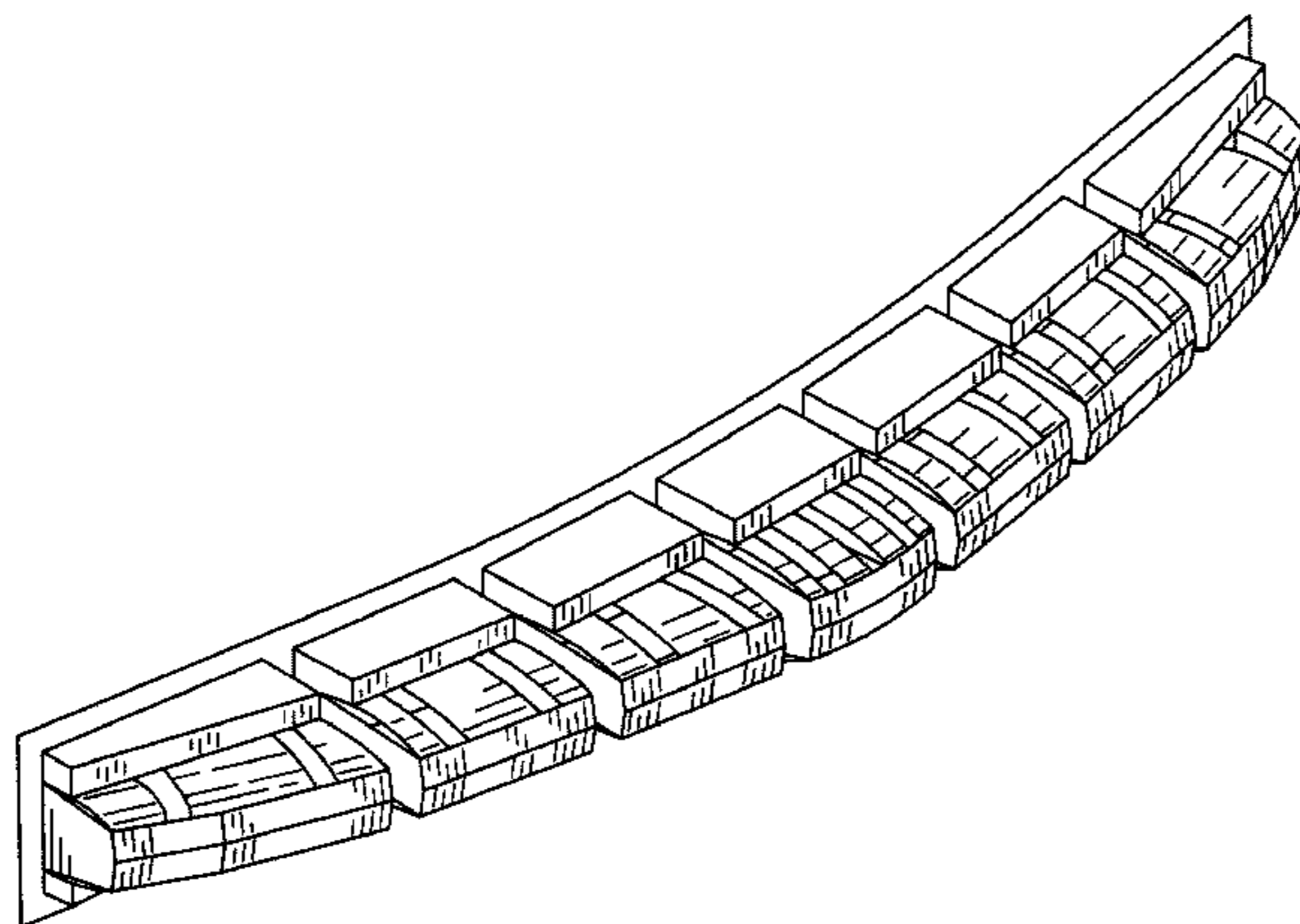

FIG. 9 is a front perspective view of an energy absorber for a vehicle bumper unit, showing a second embodiment of our new design;

FIG. 10 is a rear perspective view of the embodiment shown in FIG. 9;

FIG. 11 is a top plan view of the embodiment shown in FIG. 9;

FIG. 12 is a front elevation view of the embodiment shown in FIG. 9;

FIG. 13 is a bottom plan view of the embodiment shown in FIG. 9;

FIG. 14 is a rear elevation view of the embodiment shown in FIG. 9;

FIG. 15 is a left elevation view of the embodiment shown in FIG. 9; and

FIG. 16 is a right elevation view of the embodiment shown in FIG. 9.

FIG. 17 is a front perspective view of an energy absorber for a vehicle bumper unit, showing a third embodiment of our new design;

FIG. 18 is a rear perspective view of the embodiment shown in FIG. 17;

FIG. 19 is a top plan view of the embodiment shown in FIG. 17;

FIG. 20 is a front elevation view of the embodiment shown in FIG. 17;

FIG. 21 is a bottom plan view of the embodiment shown in FIG. 17;

FIG. 22 is a rear elevation view of the embodiment shown in FIG. 17;

FIG. 23 is a left elevation view of the embodiment shown in FIG. 17; and

FIG. 24 is a right elevation view of the embodiment shown in FIG. 17.

FIG. 25 is a front perspective view of an energy absorber for a vehicle bumper unit, showing a fourth embodiment of our new design;

FIG. 26 is a rear perspective view of the embodiment shown in FIG. 25;

FIG. 27 is a top plan view of the embodiment shown in FIG. 25;

FIG. 28 is a front elevation view of the embodiment shown in FIG. 25;

FIG. 29 is a bottom plan view of the embodiment shown in FIG. 25;

FIG. 30 is a rear elevation view of the embodiment shown in FIG. 25

FIG. 31 is a left elevation view of the embodiment shown in FIG. 25; and,

FIG. 32 is a right elevation view of the embodiment shown in FIG. 25.

The broken lines shown throughout the drawing disclosure are for illustrative purposes only and form no part of the claimed design.

1 Claim, 20 Drawing Sheets

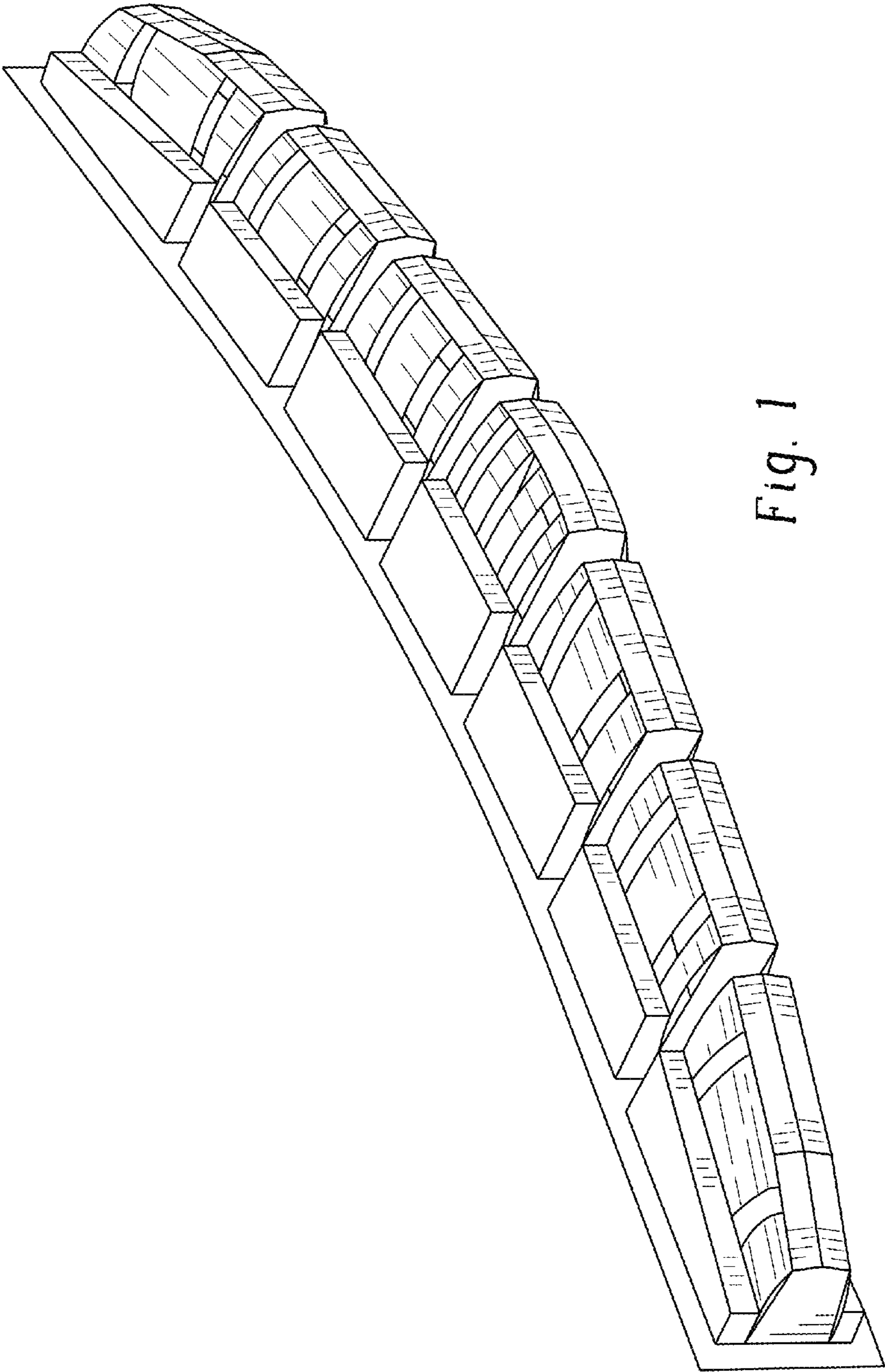

Fig. 1

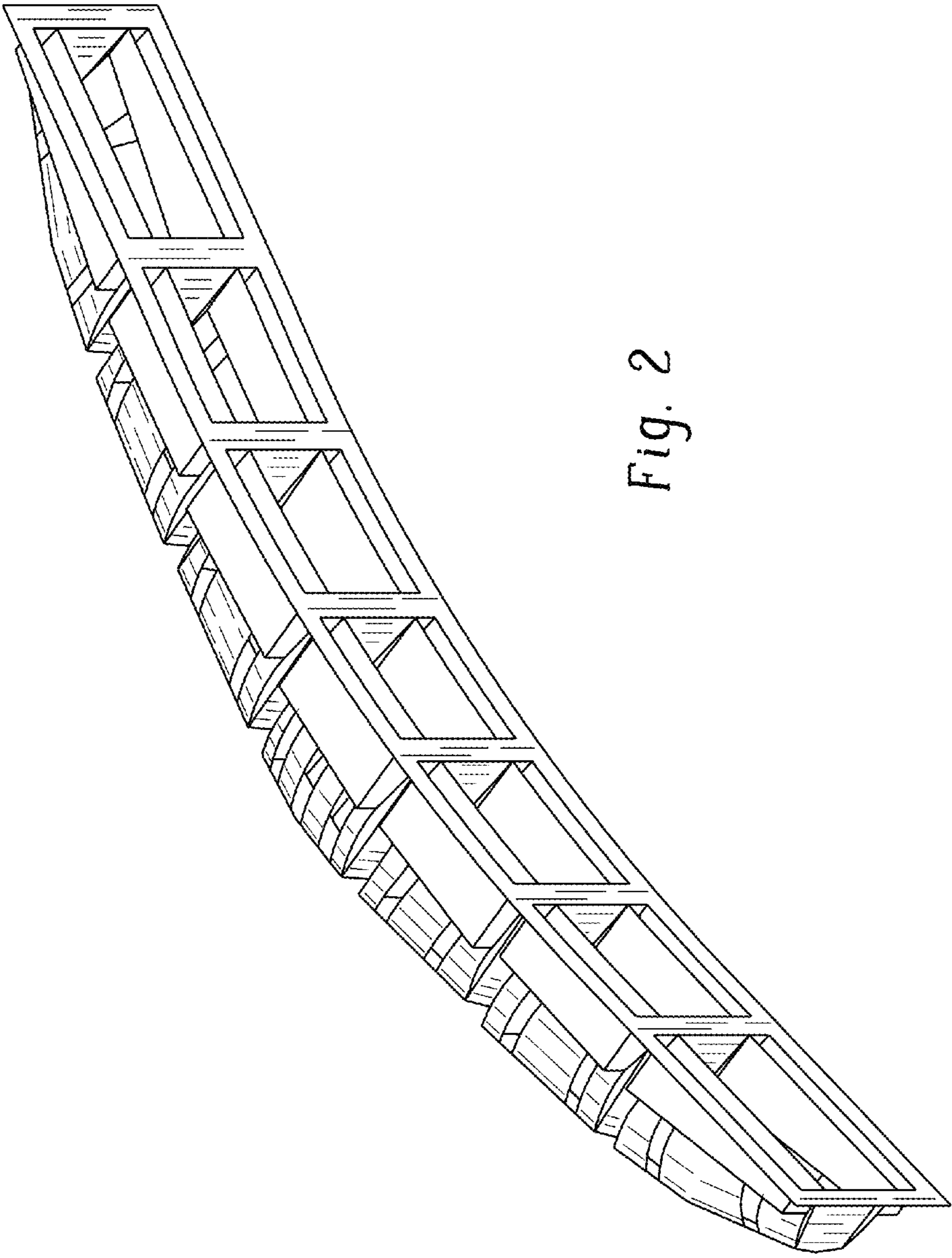

Fig. 2

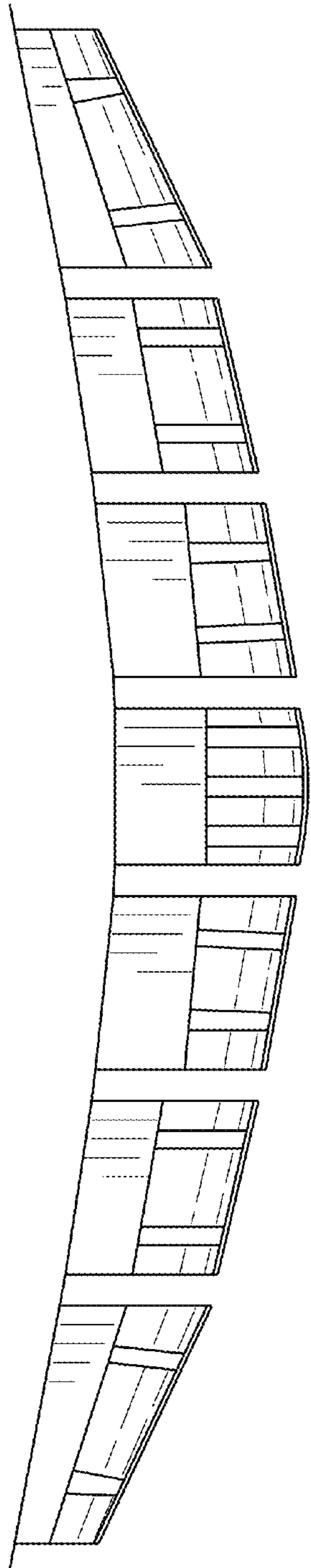

Fig. 3

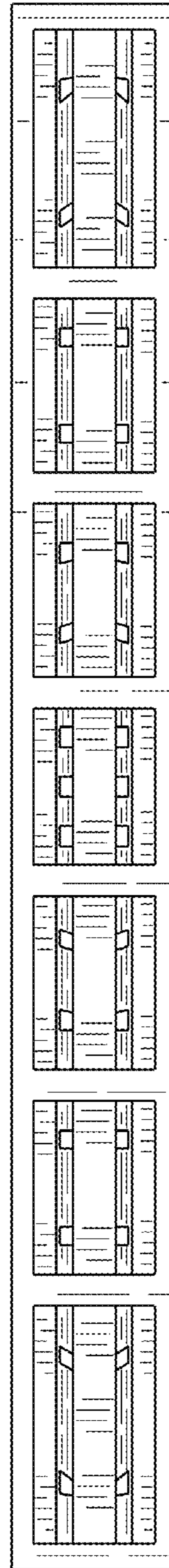

Fig. 4

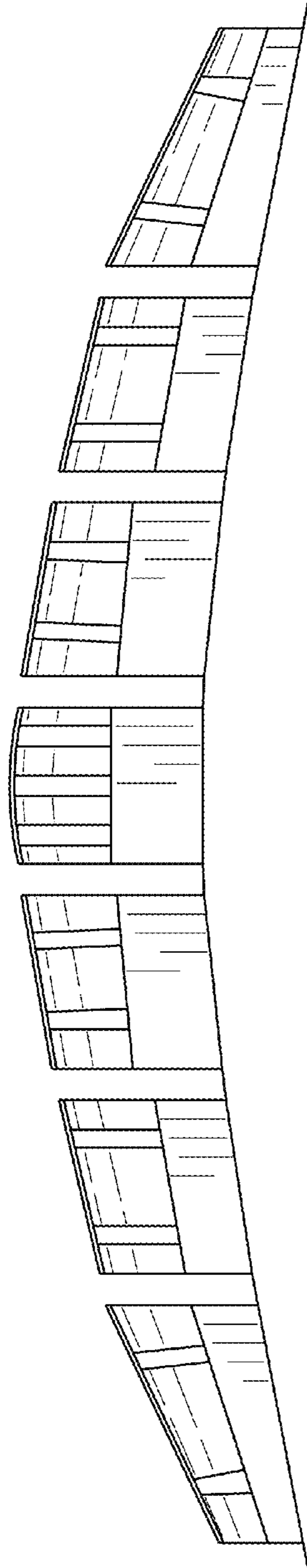

Fig. 5

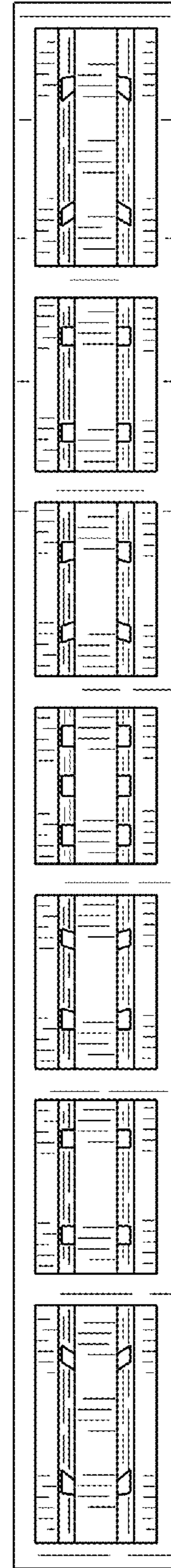

Fig. 6

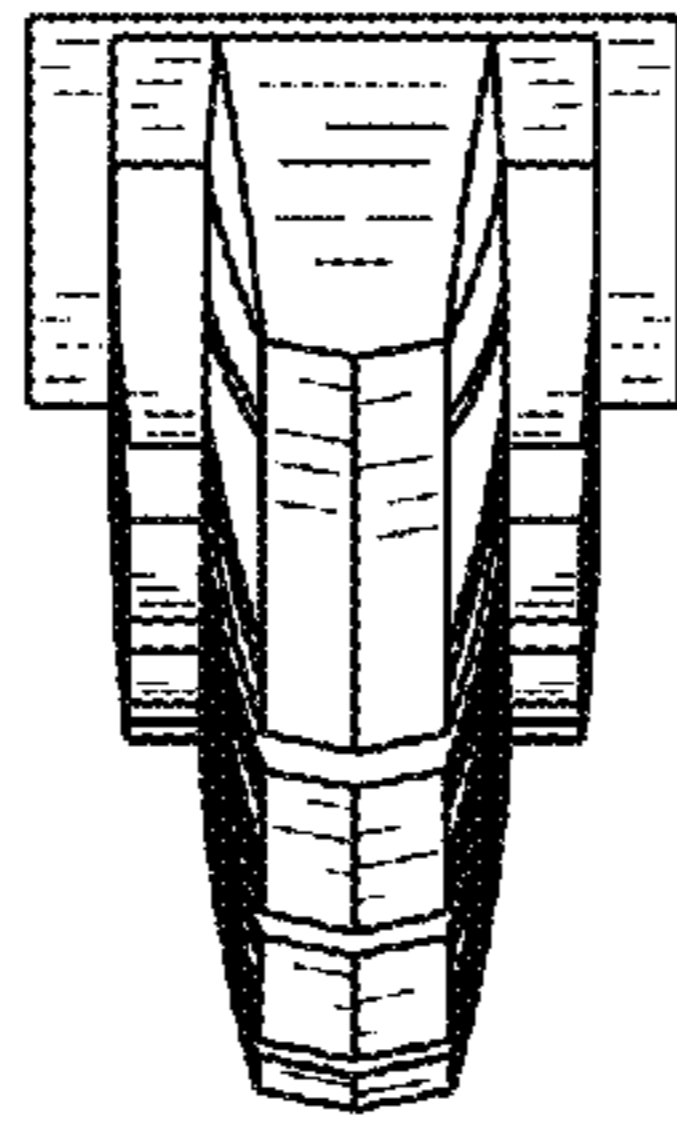

Fig. 8

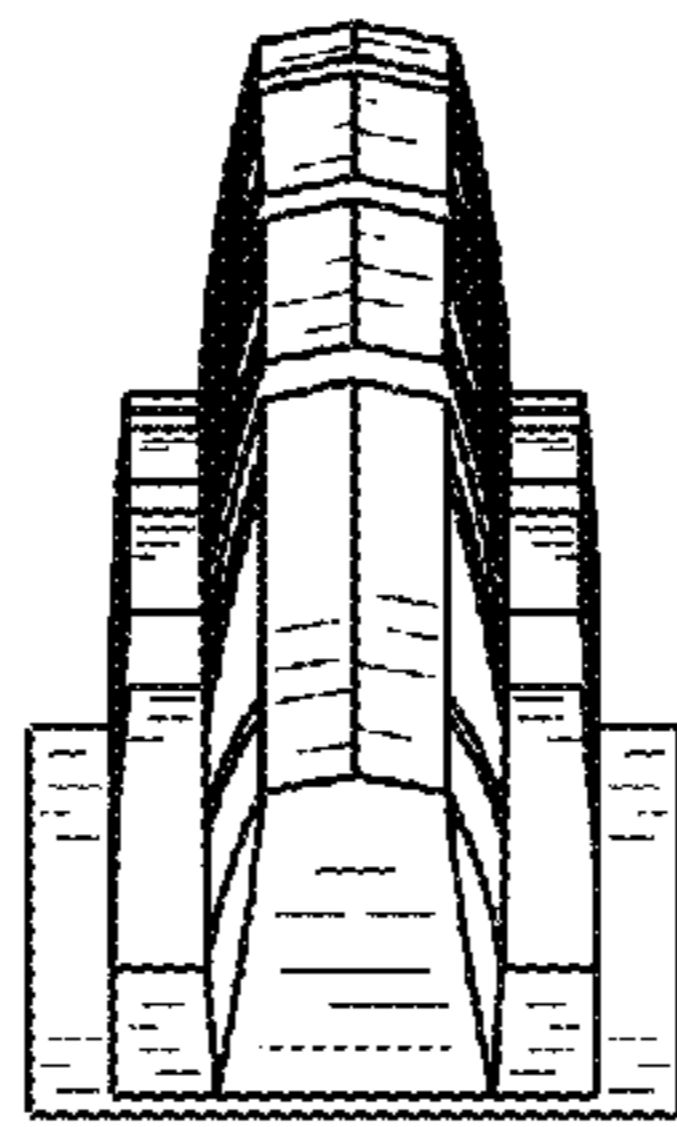

Fig. 7

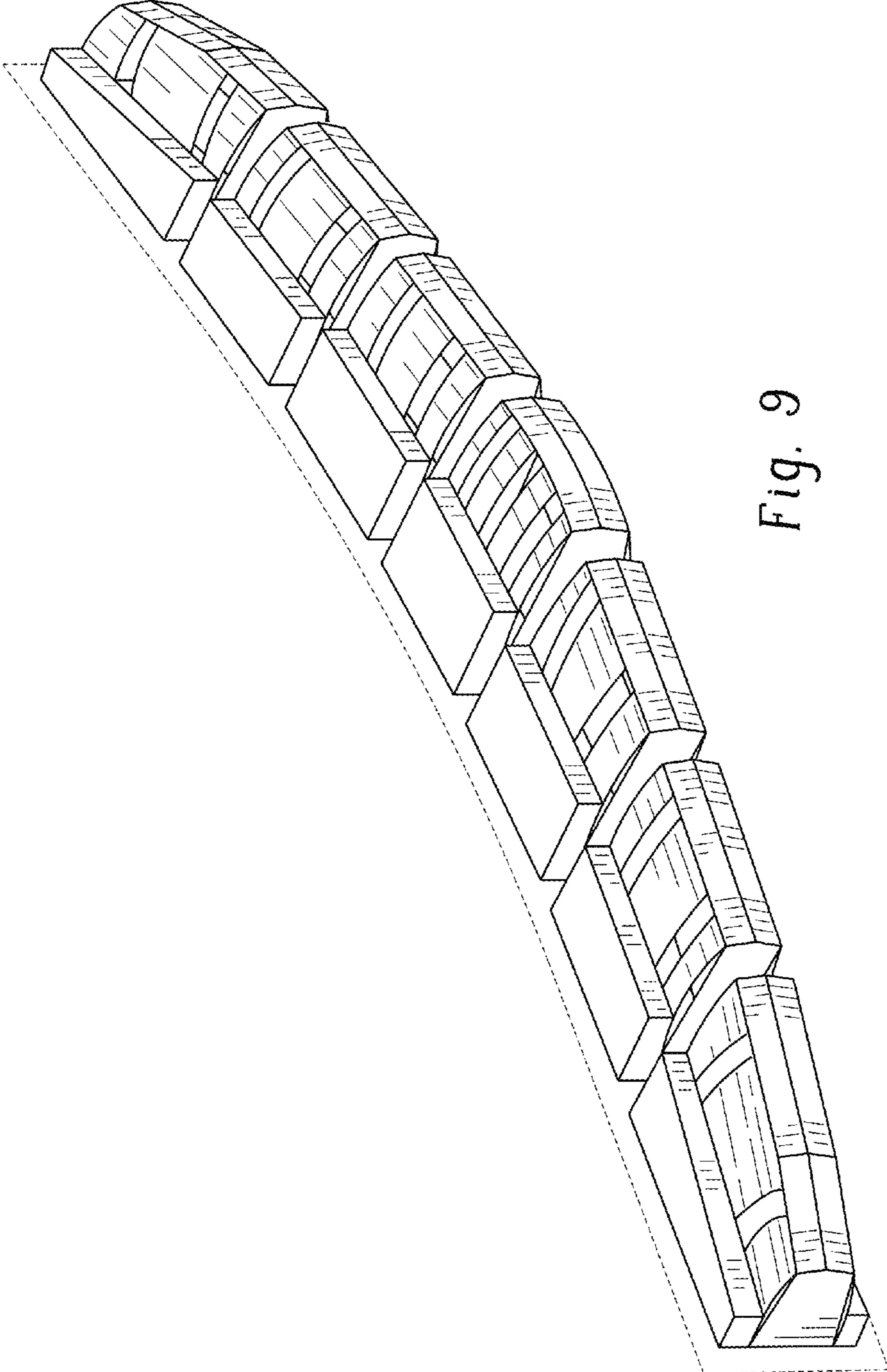

Fig. 9

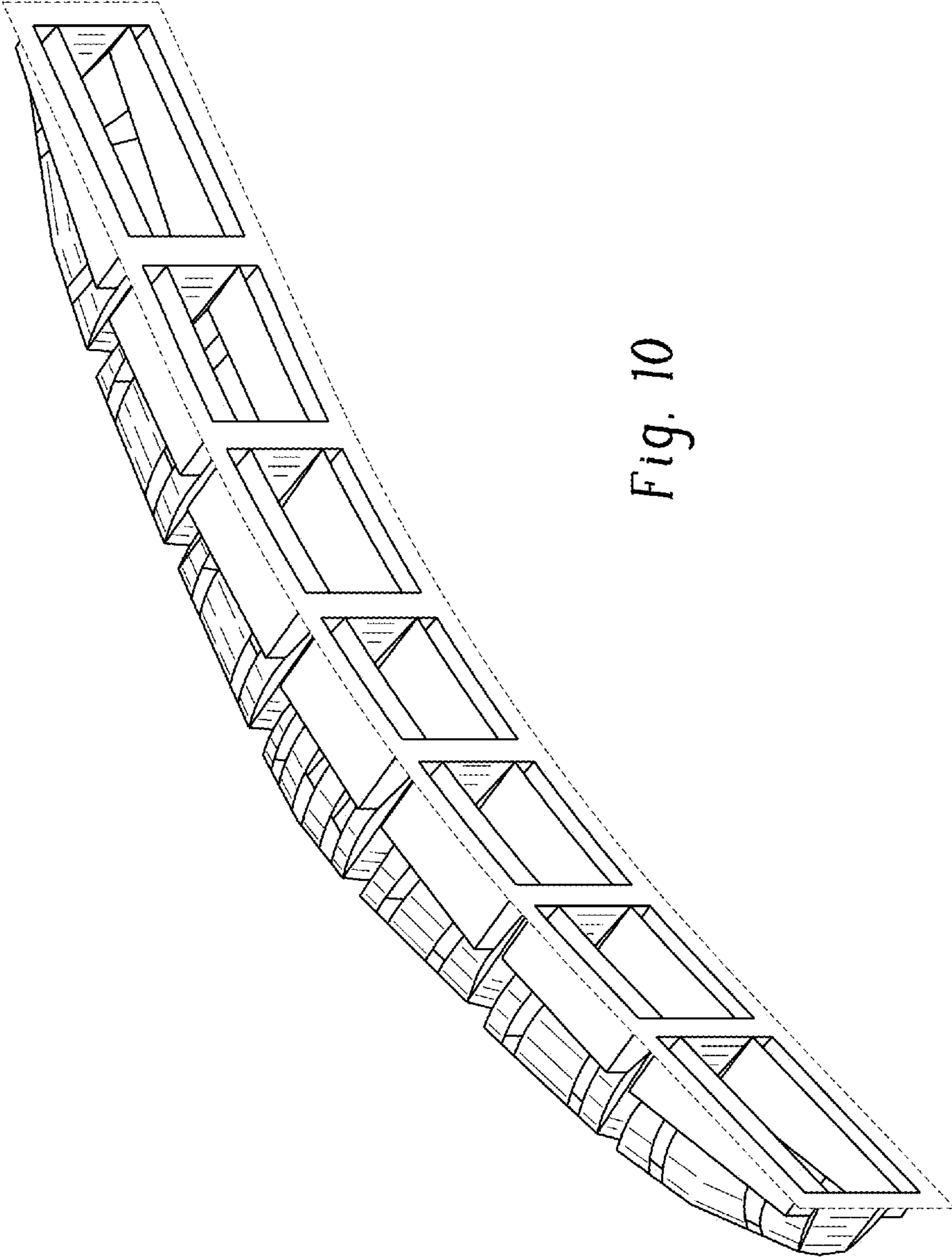

Fig. 10

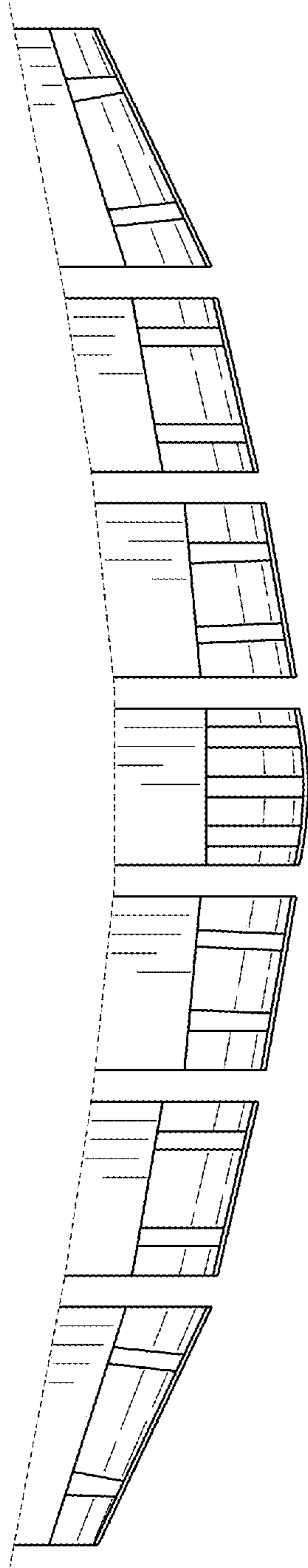

Fig. 11

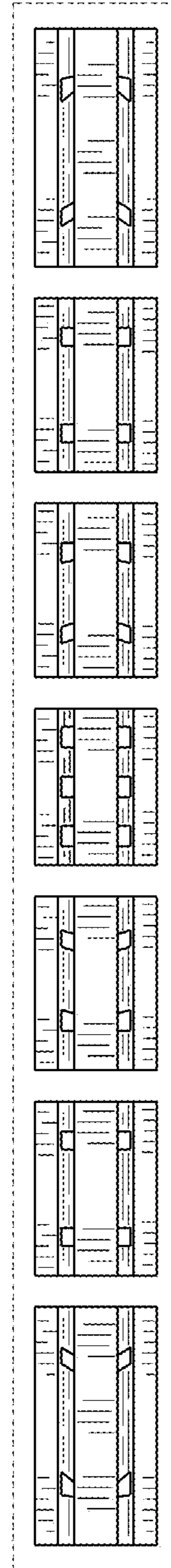

Fig. 12

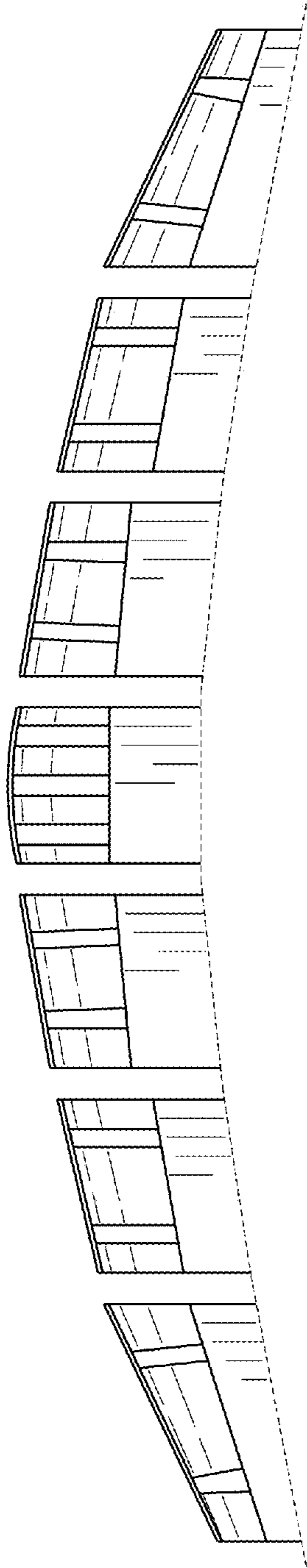

Fig. 13

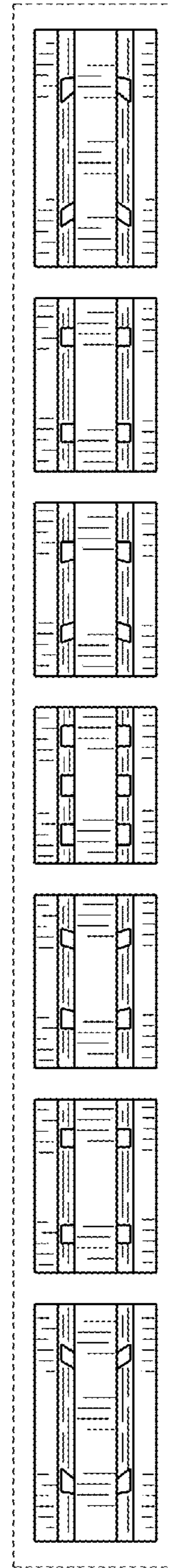

Fig. 14

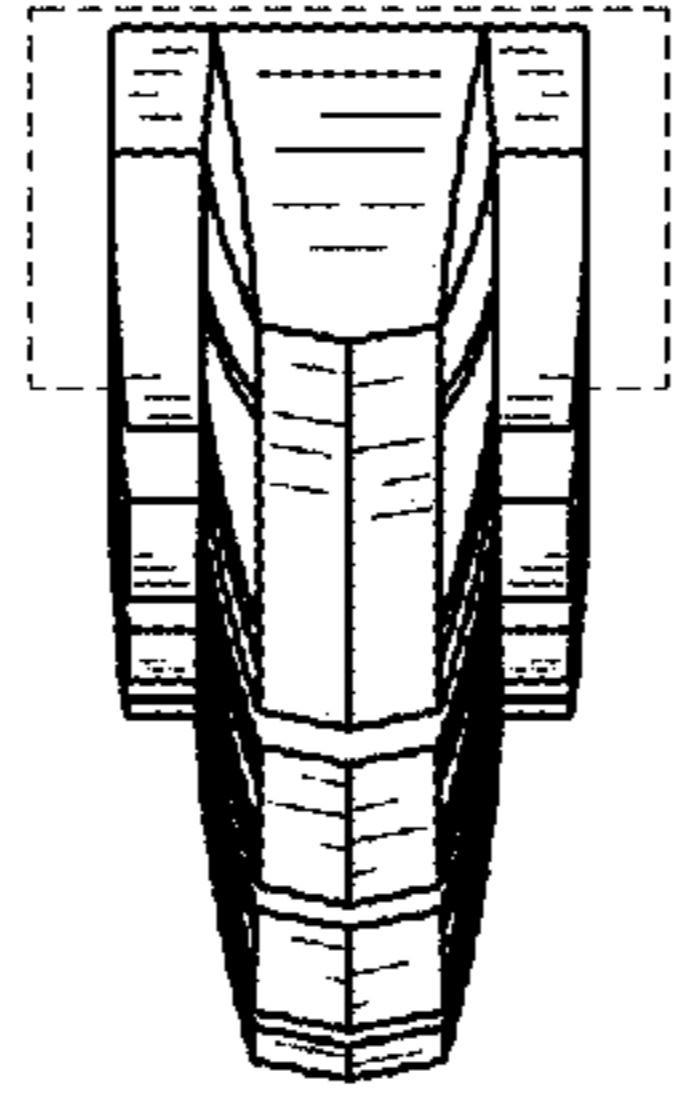

Fig. 16

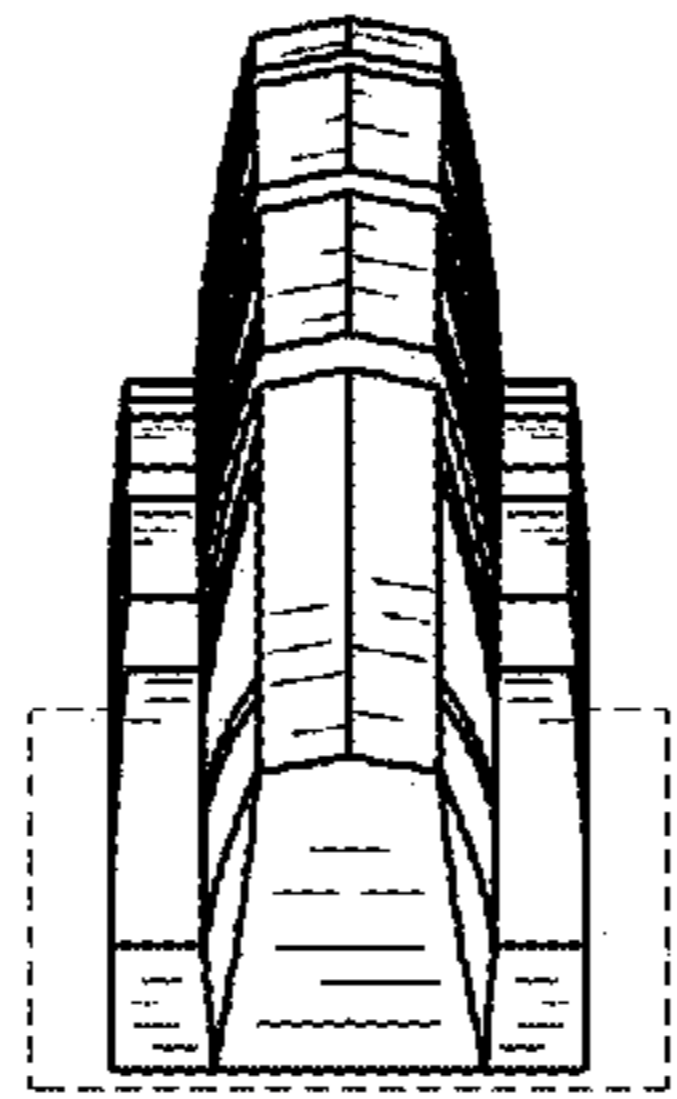

Fig. 15

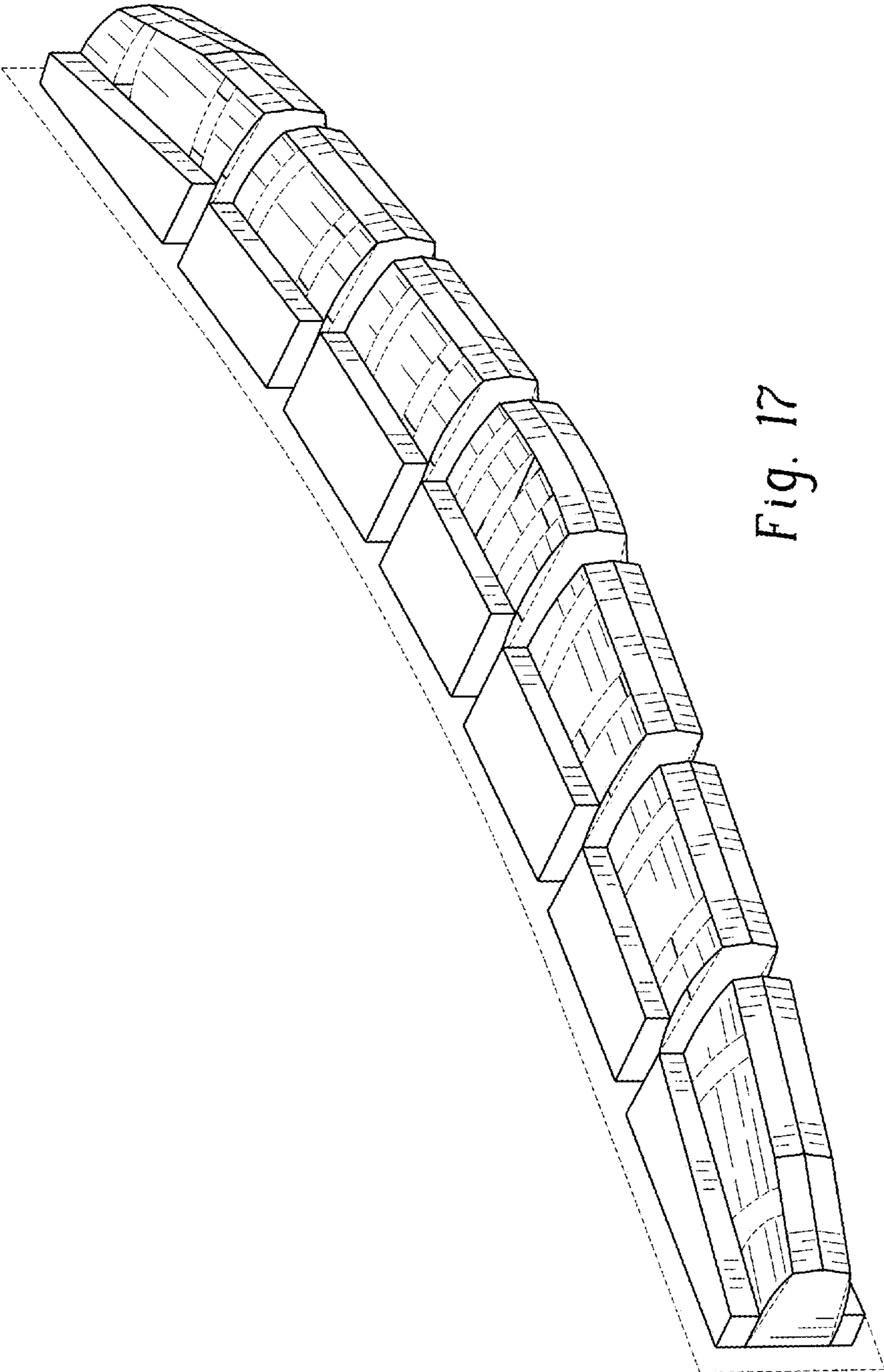

Fig. 17

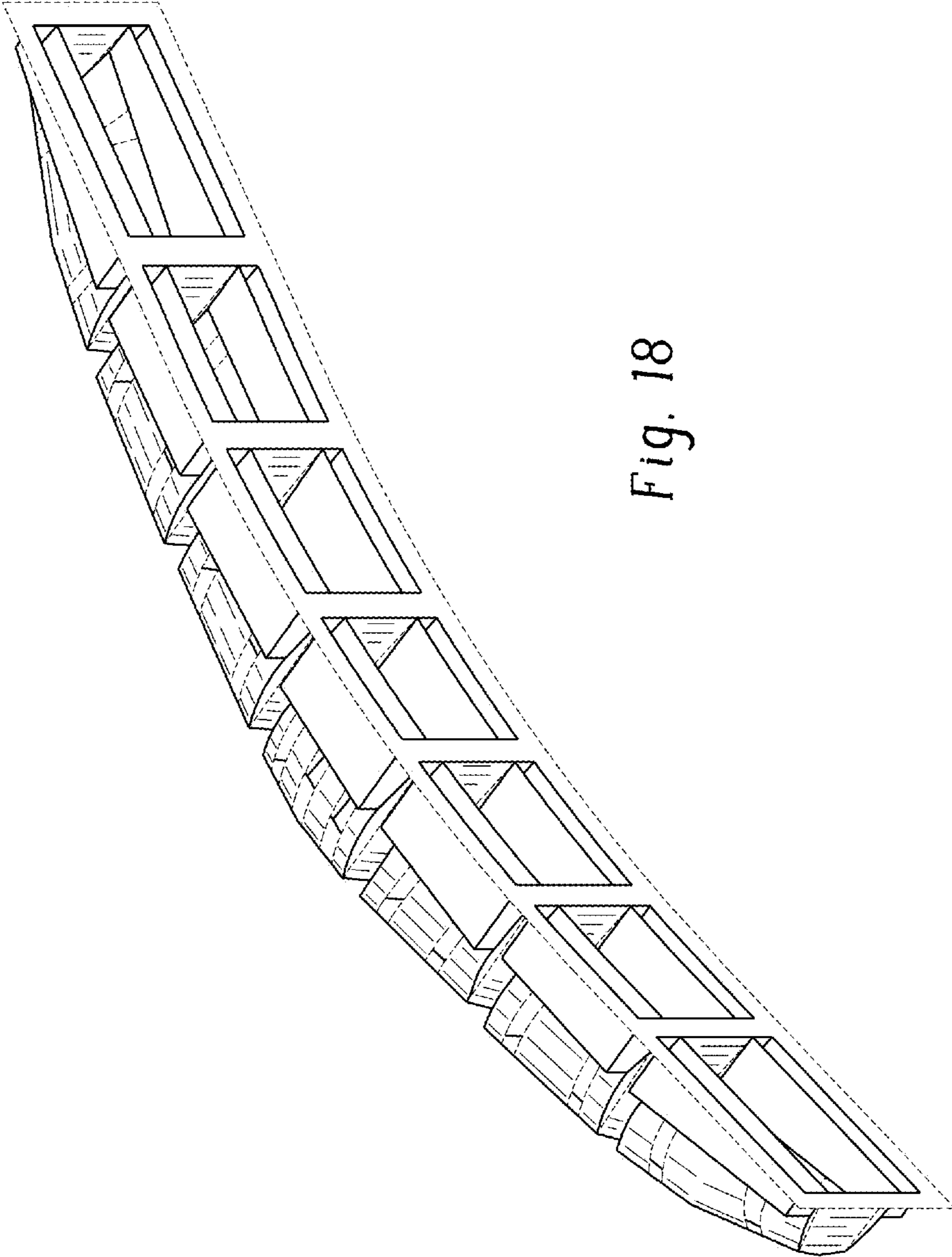

Fig. 18

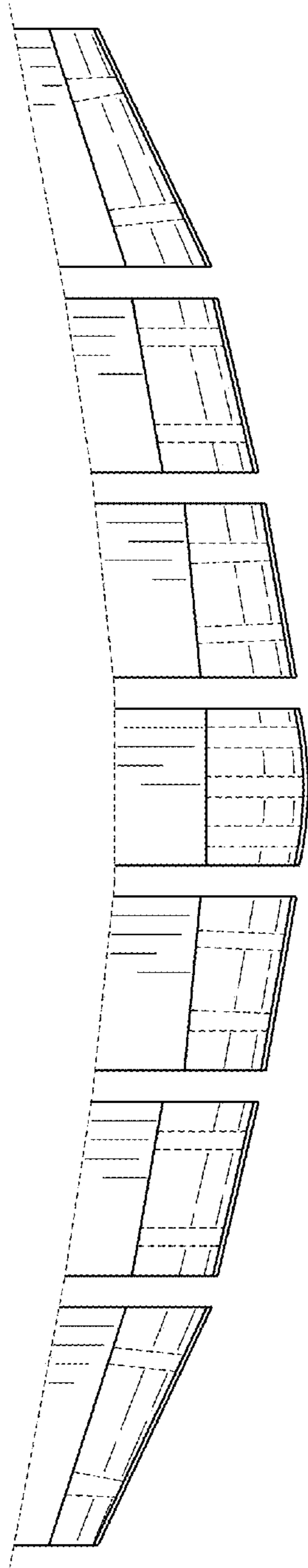

Fig. 19

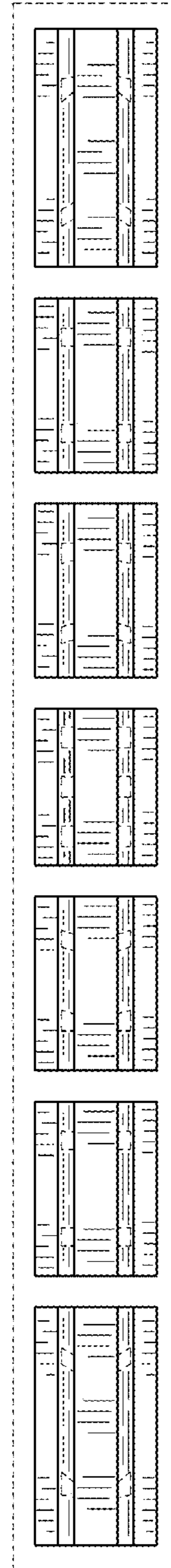

Fig. 20

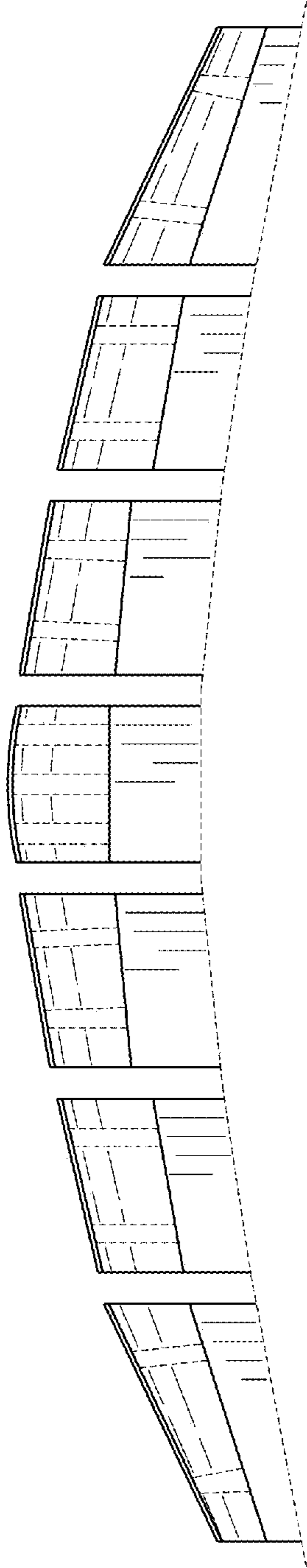

Fig. 21

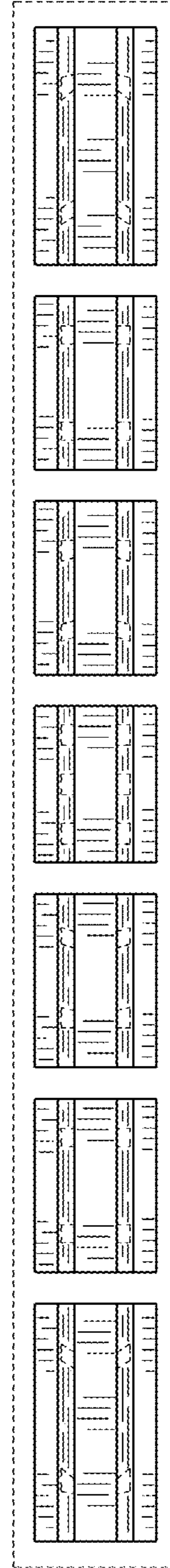

Fig. 22

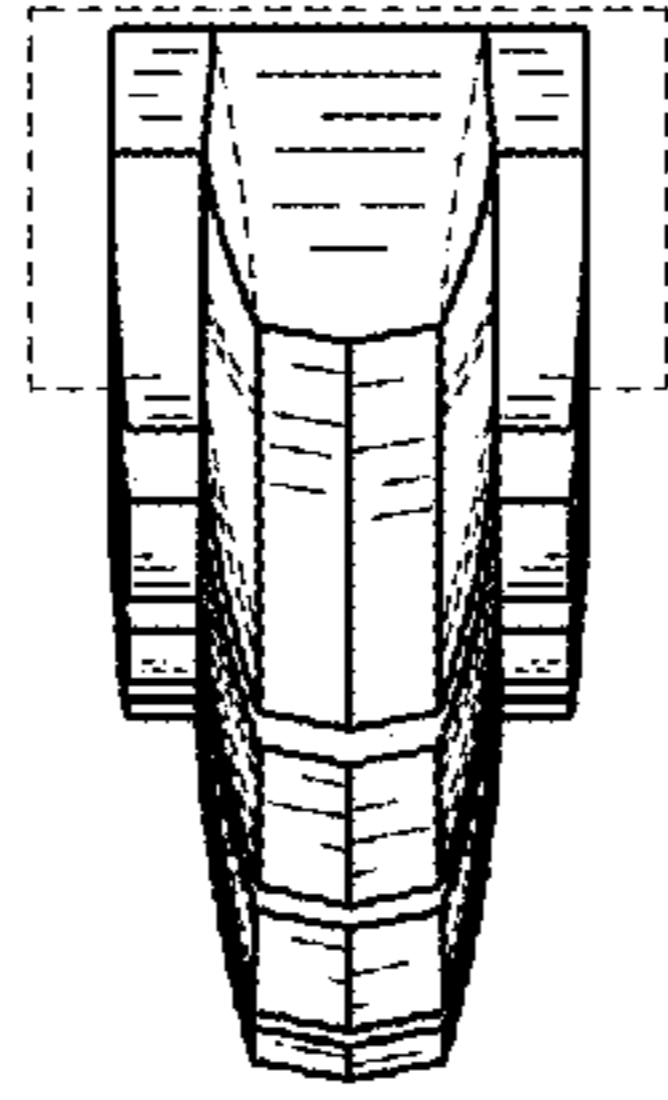

Fig. 24

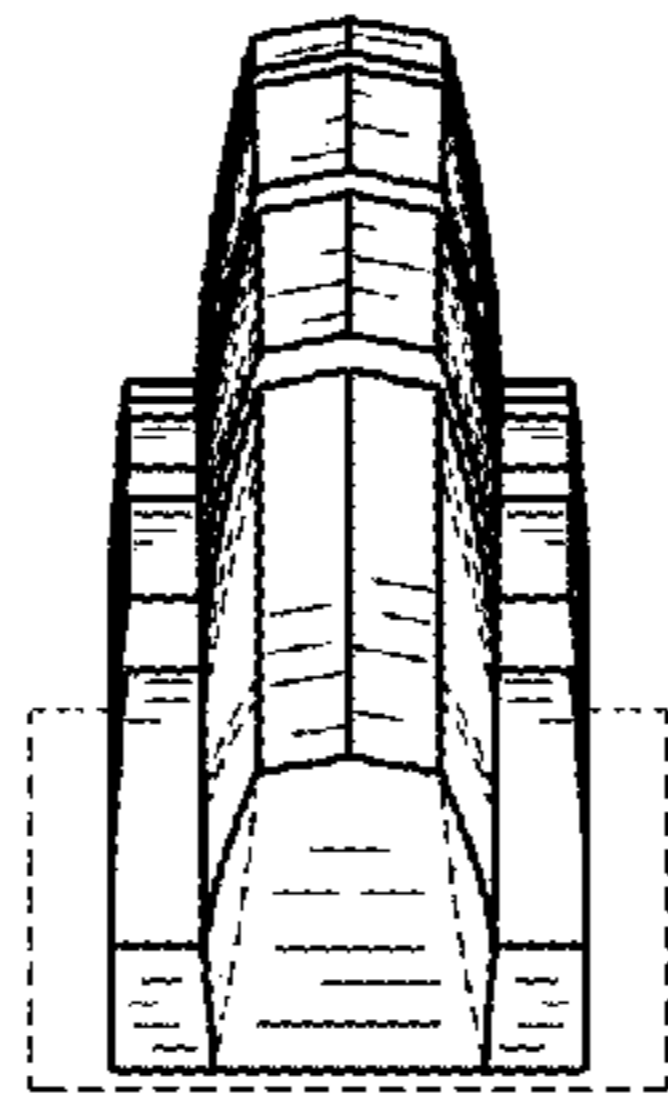

Fig. 23

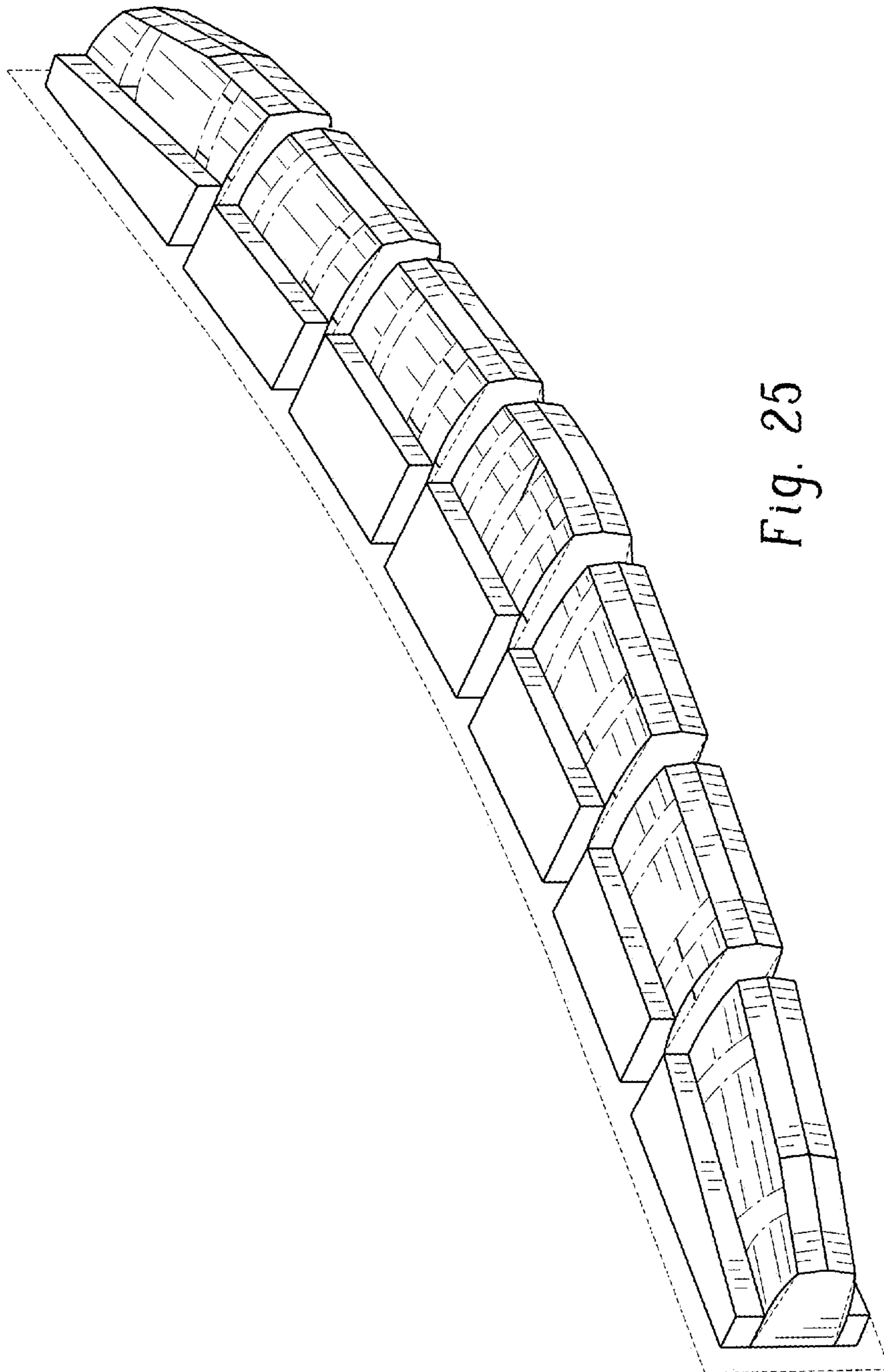

Fig. 25

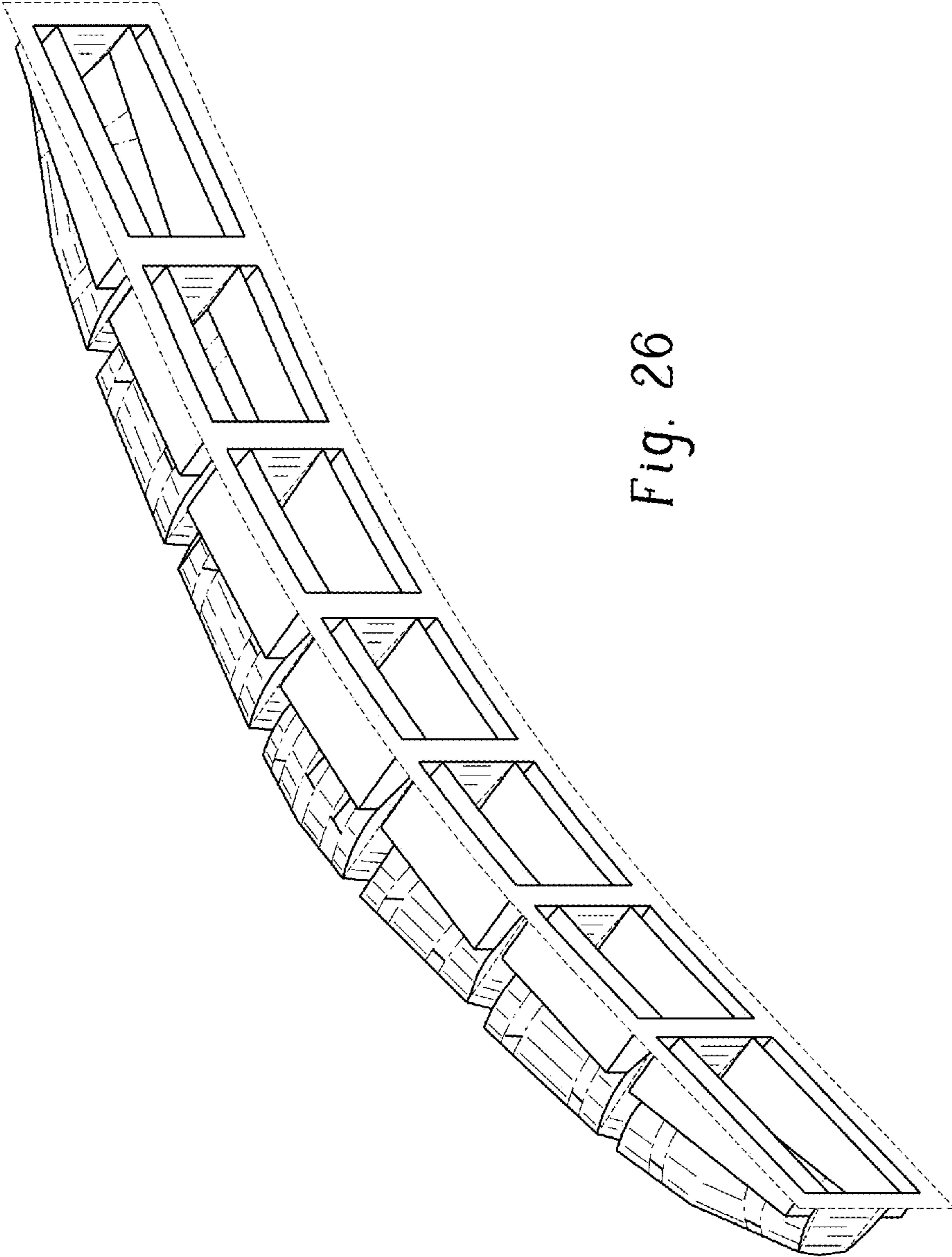

Fig. 26

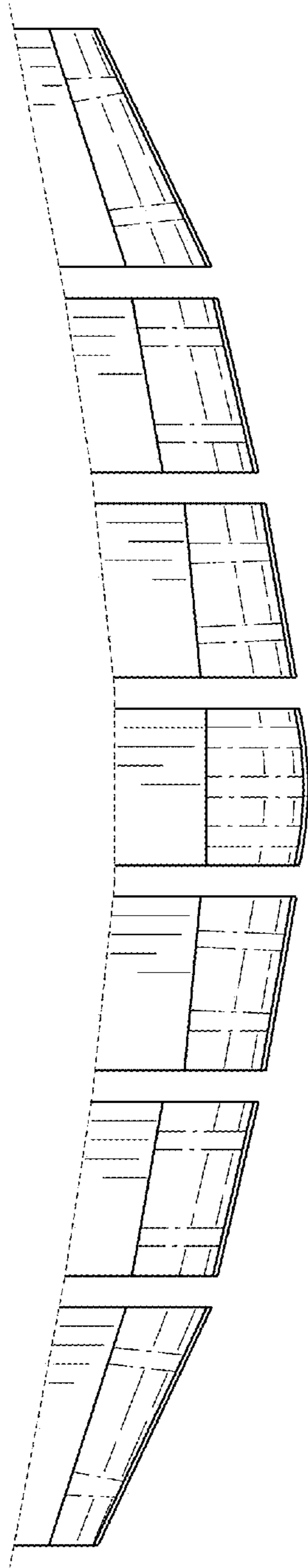

Fig. 27

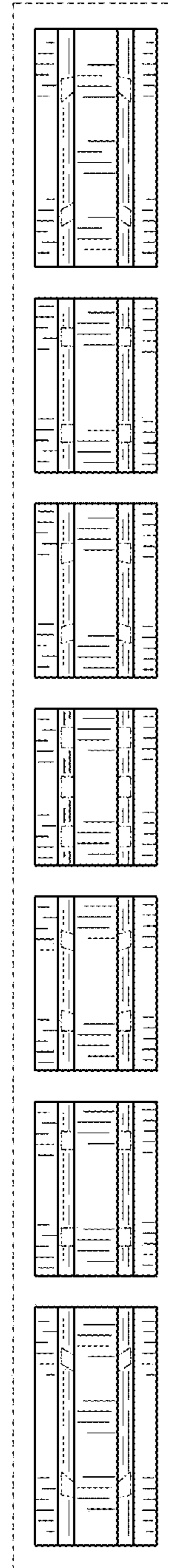

Fig. 28

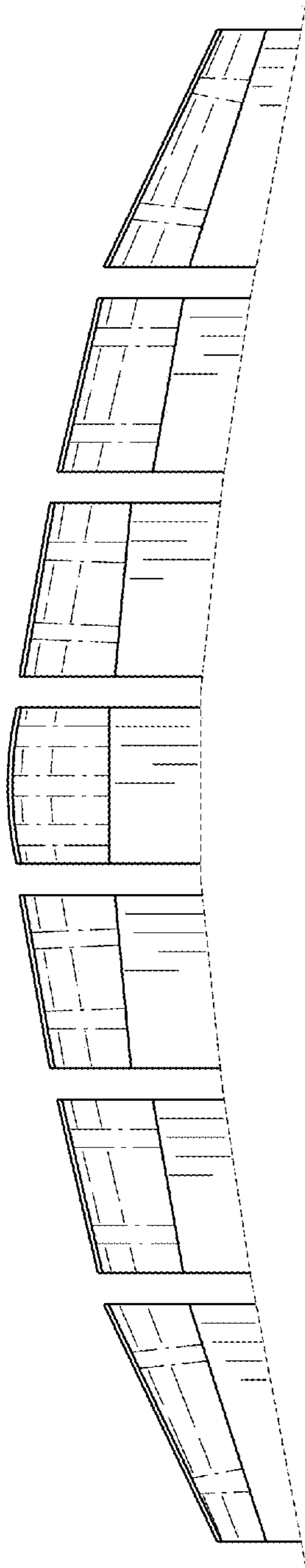

Fig. 29

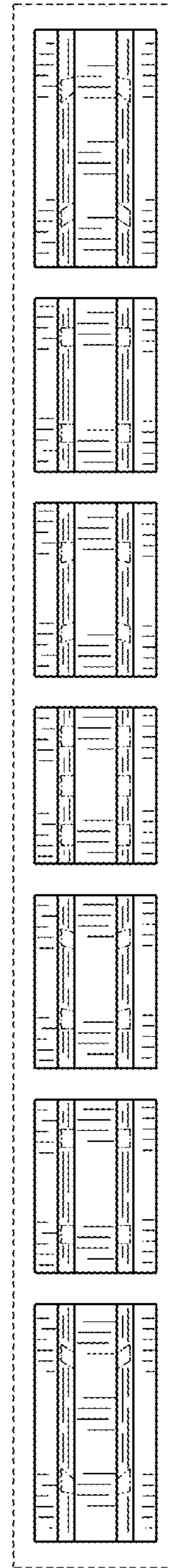

Fig. 30

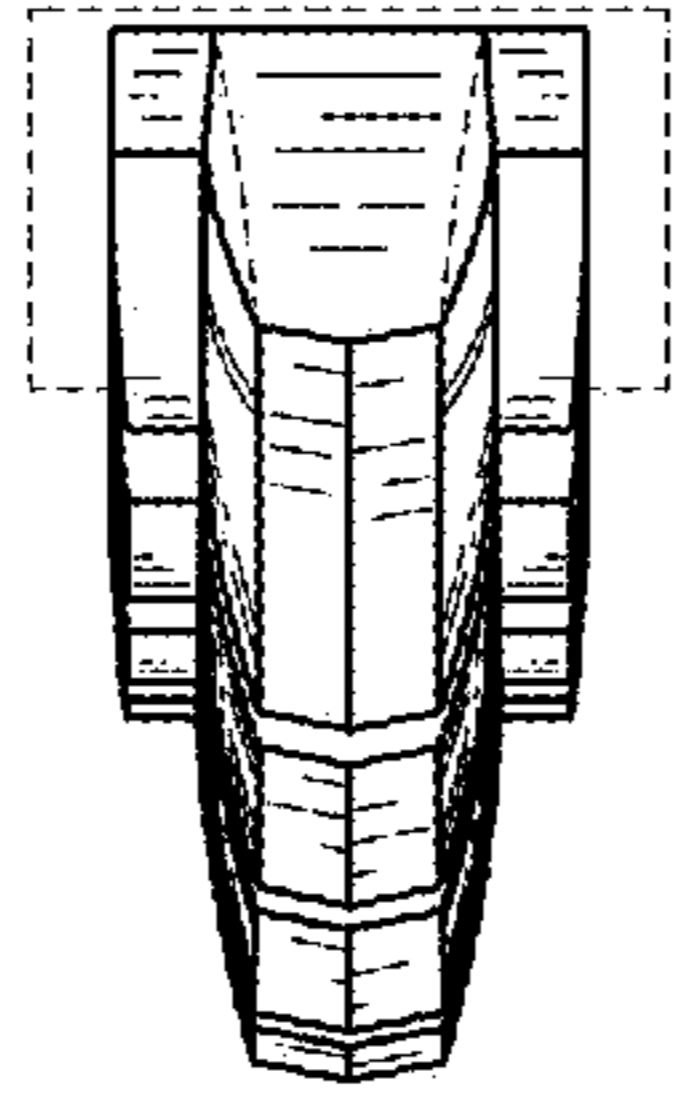

Fig. 32

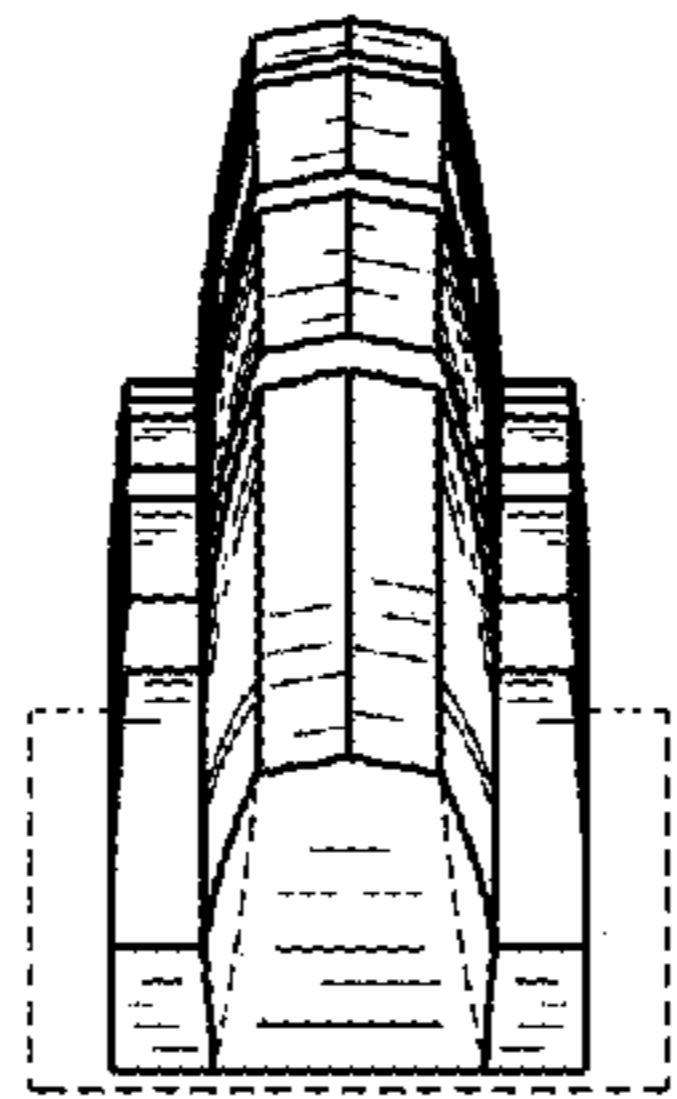

Fig. 31