



US00D670108S

(12) **United States Design Patent**  
**Nakao et al.**

(10) **Patent No.:** **US D670,108 S**  
(45) **Date of Patent:** **\*\* Nov. 6, 2012**

(54) **ELECTRONIC PERCUSSION INSTRUMENT STAND**

Product: KP125 by Yamaha taken from: <http://yamaha.jp/product/drums/el-drums/kick-pads/kp125/> dated Oct. 29, 2009.

(75) Inventors: **Koichi Nakao**, Hamamatsu (JP);  
**Yoshiaki Mori**, Hamamatsu (JP)

\* cited by examiner

(73) Assignee: **Roland Corporation**, Hamamatsu (JP)

*Primary Examiner* — Sydney Buffalow

(\*\*) Term: **14 Years**

(74) *Attorney, Agent, or Firm* — **Foley & Lardner LLP**

(21) Appl. No.: **29/346,357**

(22) Filed: **Oct. 30, 2009**

(57) **CLAIM**  
We claim the ornamental design for an electronic percussion instrument stand, as shown and described.

(30) **Foreign Application Priority Data**

**DESCRIPTION**

Jun. 9, 2009 (JP) ..... 2009-012967

(51) **LOC (9) Cl.** ..... **06-04**

(52) **U.S. Cl.** ..... **D6/499**

(58) **Field of Classification Search** ..... D6/466,  
D6/396, 475, 462, 450, 491, 429, 463, 495;  
248/448, 167, 166, 122.1, 443, 434, 201,  
248/150; 84/327, 421, 329, 453; D17/22;  
D7/619.1; D21/385

See application file for complete search history.

FIG. 1 is a front view of a electronic percussion instrument stand showing our new design, as attached to an electronic percussion instrument.

FIG. 2 is a rear view thereof.

FIG. 3 is a left side view thereof.

FIG. 4 is a right side view thereof.

FIG. 5 is a top view thereof.

FIG. 6 is a bottom view thereof.

FIG. 7 is a perspective view thereof, as also attached to a foot pedal.

FIG. 8 is a front view of the electronic percussion instrument stand.

FIG. 9 is a rear view thereof.

FIG. 10 is a left side view thereof.

FIG. 11 is a right side view thereof.

FIG. 12 is a top view thereof.

FIG. 13 is a bottom view thereof

FIG. 14 is a cross-section view thereof, where the cross-section is taken along the line A-A of FIG. 8; and,

FIG. 15 is a cross-section view thereof, where the cross-section is taken along the line B-B of FIG. 8.

The ornamental design which is claimed is shown in solid lines in the drawings. The broken lines in the drawings are for illustrative purposes only and form no part of the claimed design.

(56) **References Cited**

**U.S. PATENT DOCUMENTS**

4,019,709	A *	4/1977	Mason	.....	248/150
D296,447	S *	6/1988	Jowitt	.....	D17/22
D333,231	S *	2/1993	Bareiss	.....	D6/495
D336,408	S *	6/1993	Tersch et al.	.....	D7/619.1
D537,482	S *	2/2007	Gadda et al.	.....	D21/385
D596,222	S	7/2009	Onishi		
D634,949	S *	3/2011	Babick	.....	D6/495
D650,204	S *	12/2011	Muller	.....	D6/495

**FOREIGN PATENT DOCUMENTS**

JP	01-347984	1/2009
JP	2009-128427	6/2009

**OTHER PUBLICATIONS**

Product: KP125 by Yamaha taken from: <http://yamaha.jp/product/drums/el-drums/kick-pads/kp125/> dated Oct. 29, 2009.

**1 Claim, 15 Drawing Sheets**

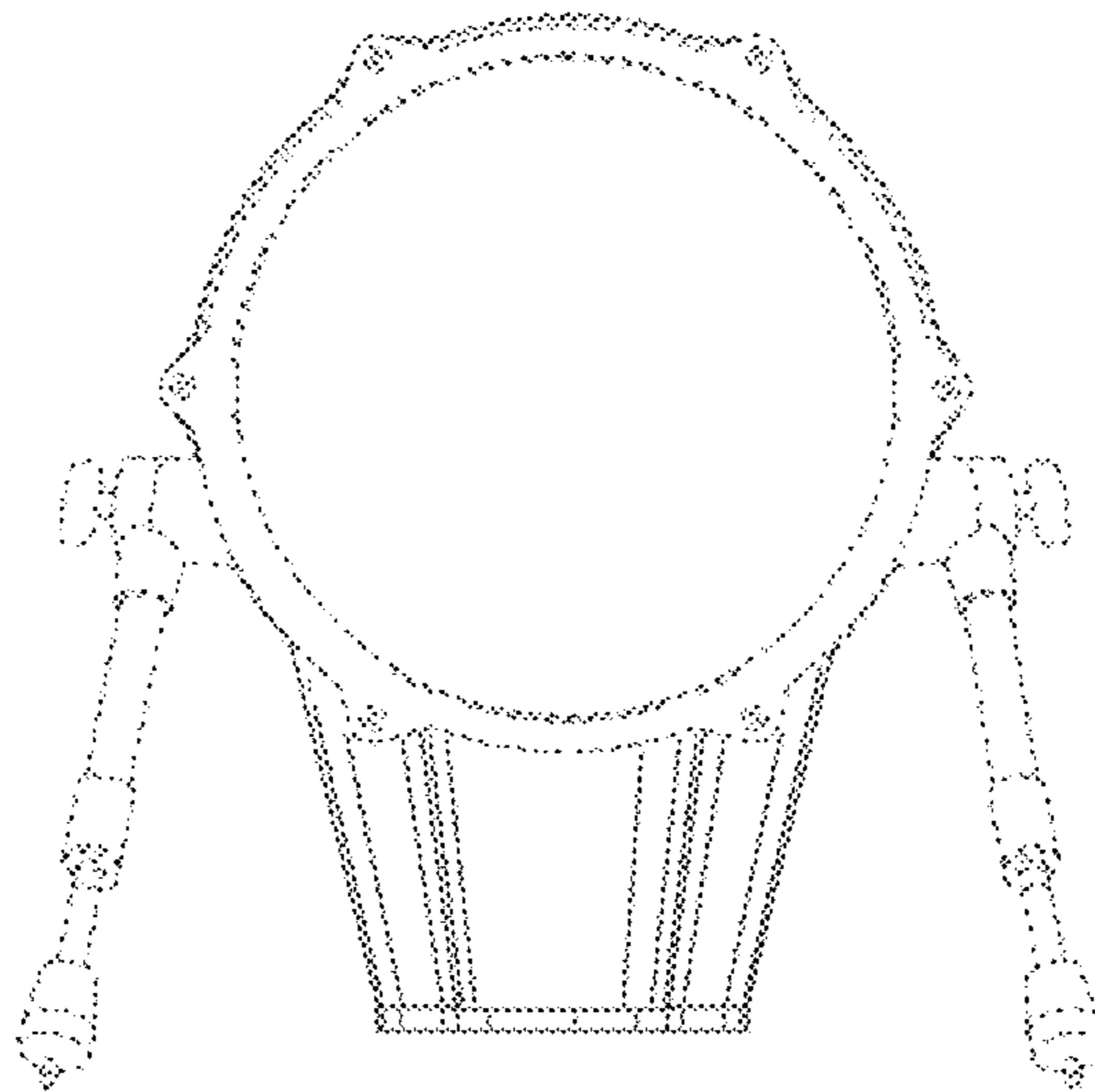

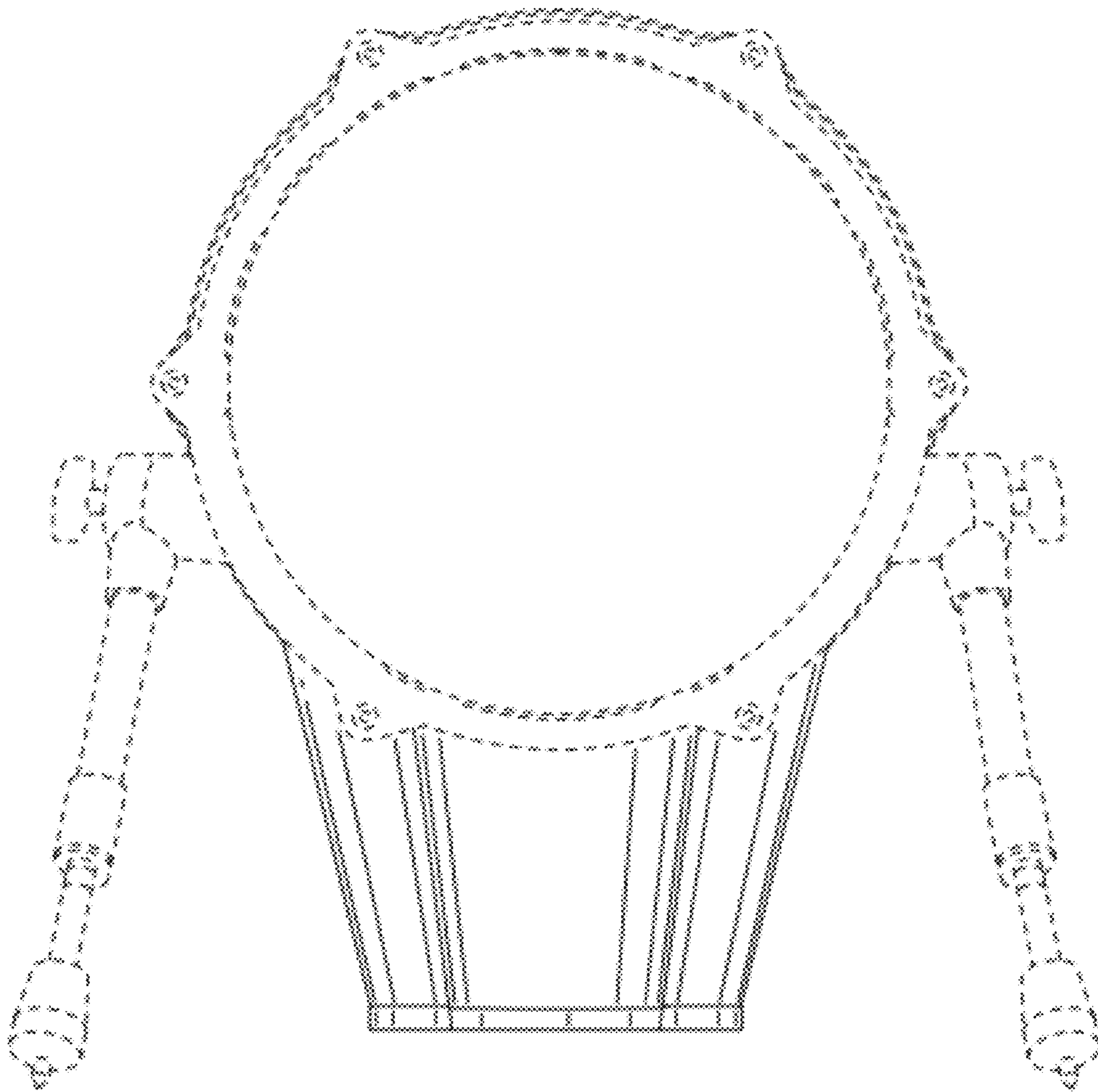

FIG. 1

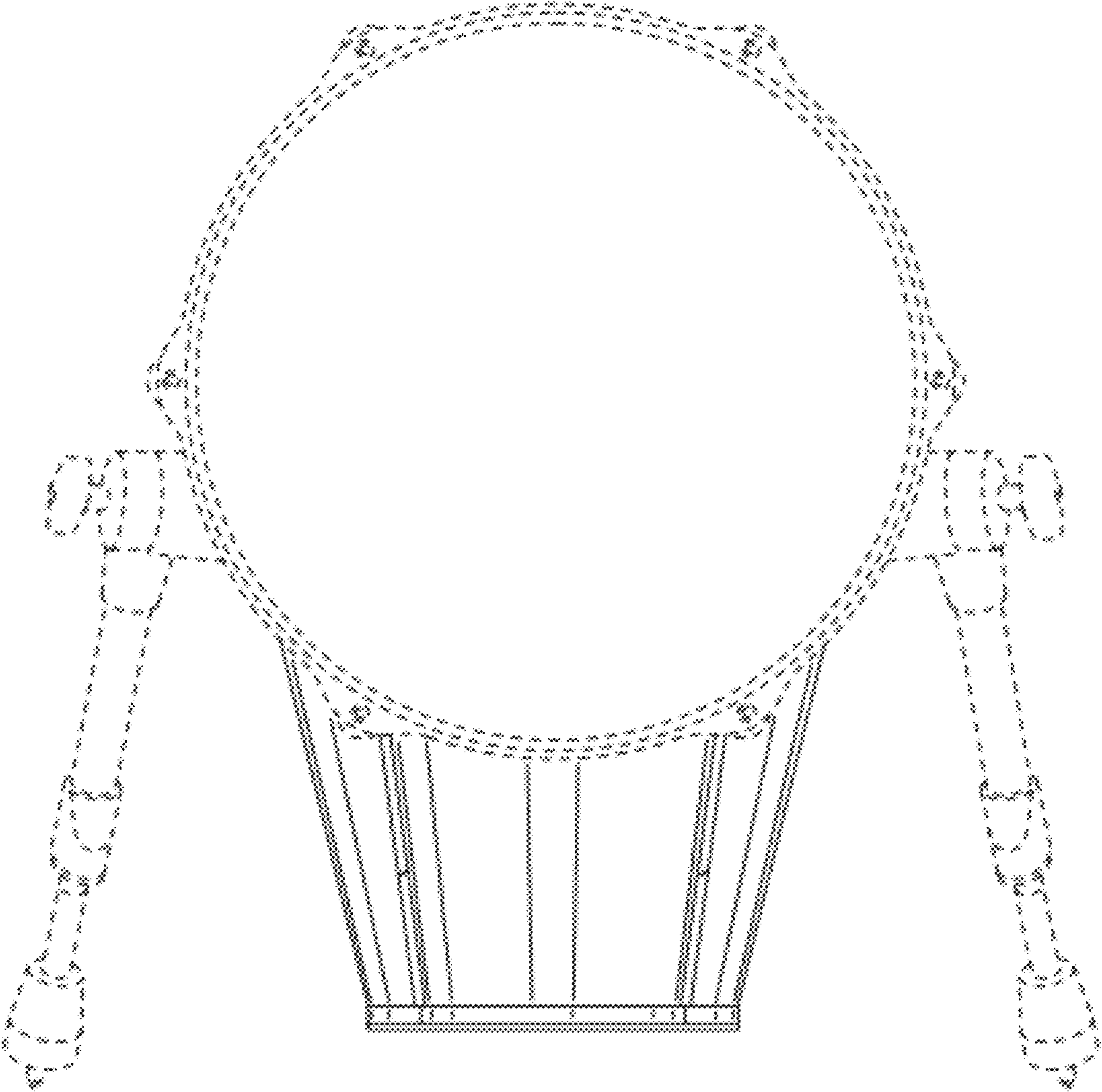

FIG. 2



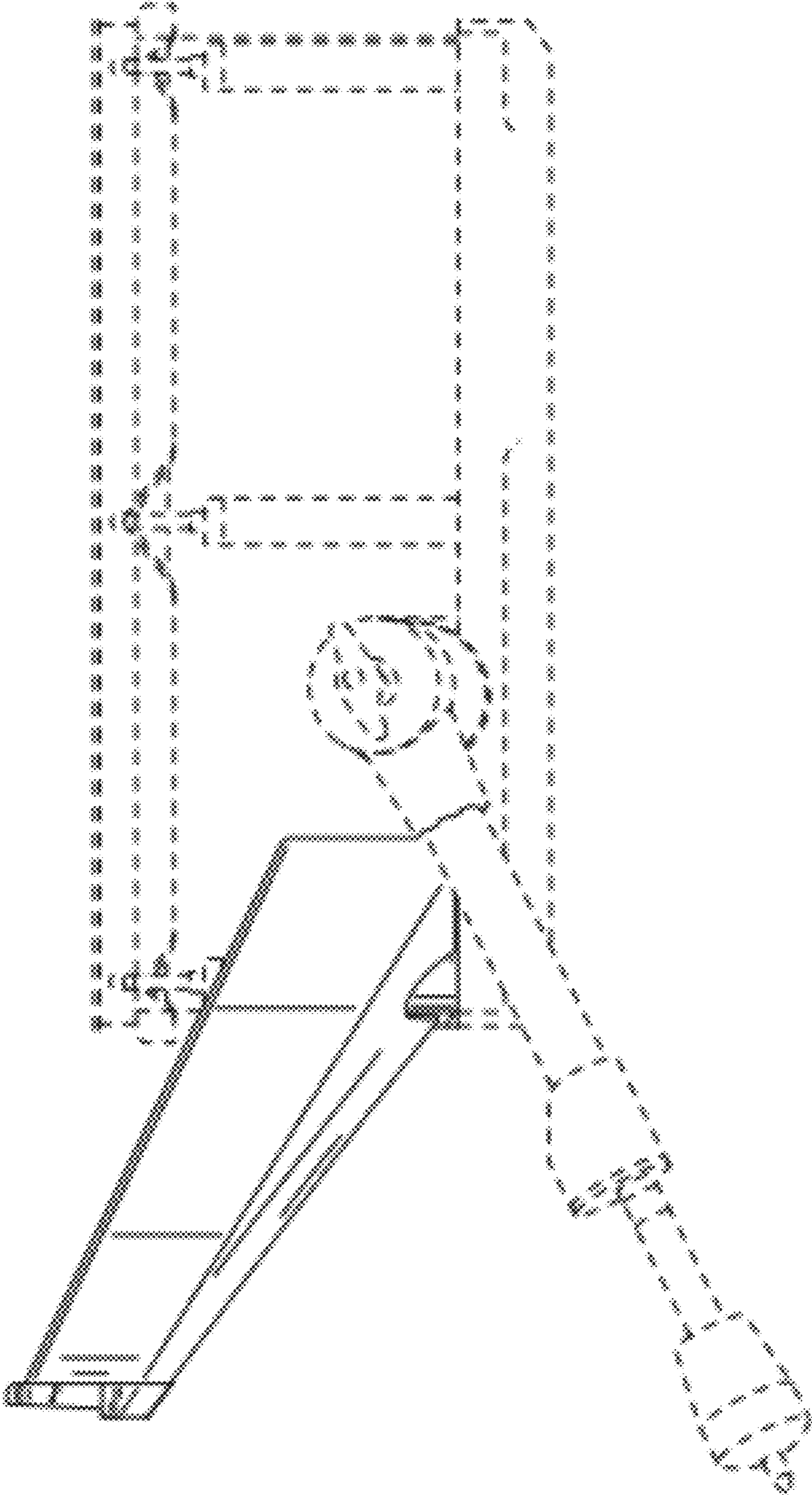

FIG. 3

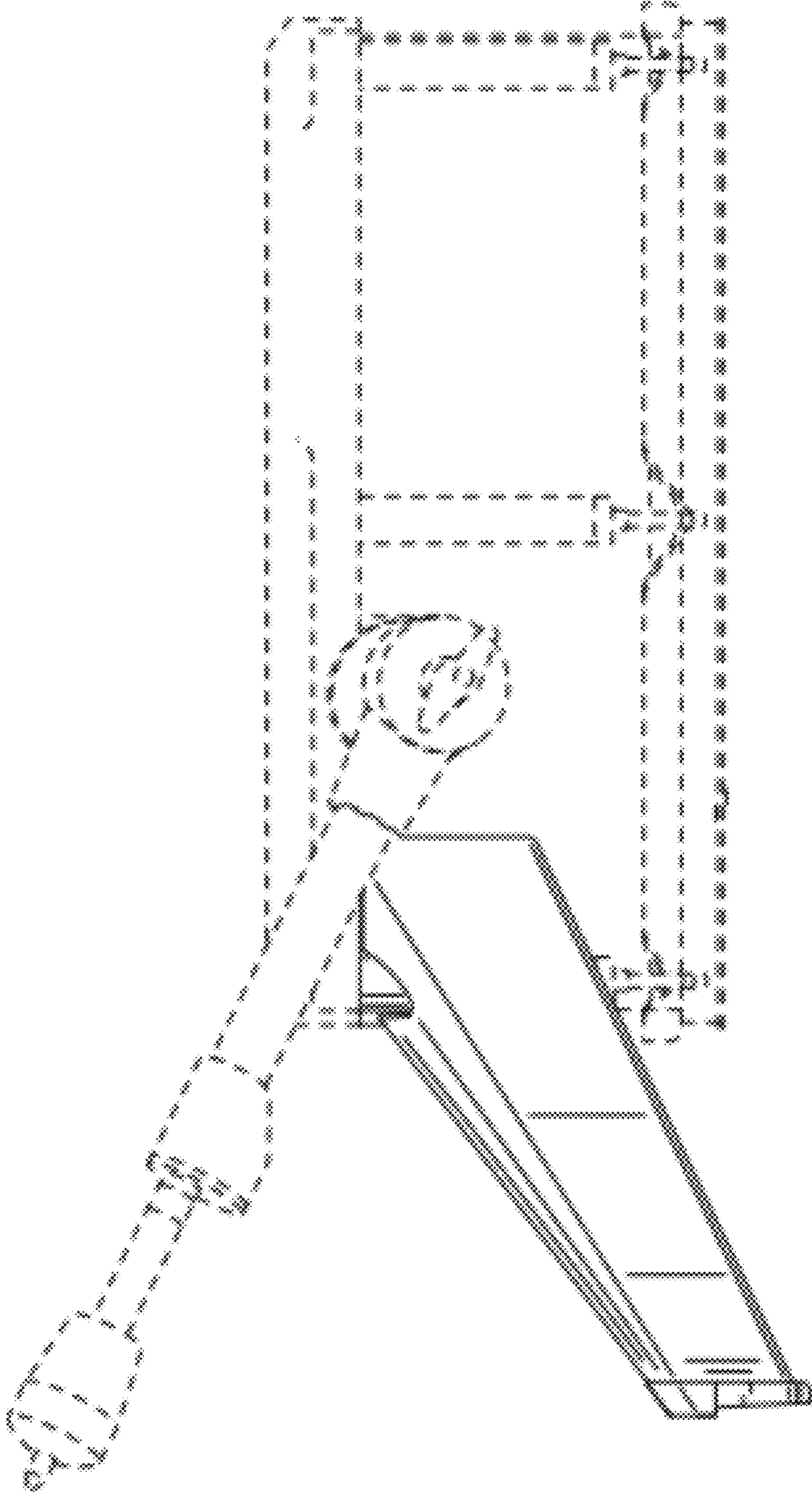

FIG. 4

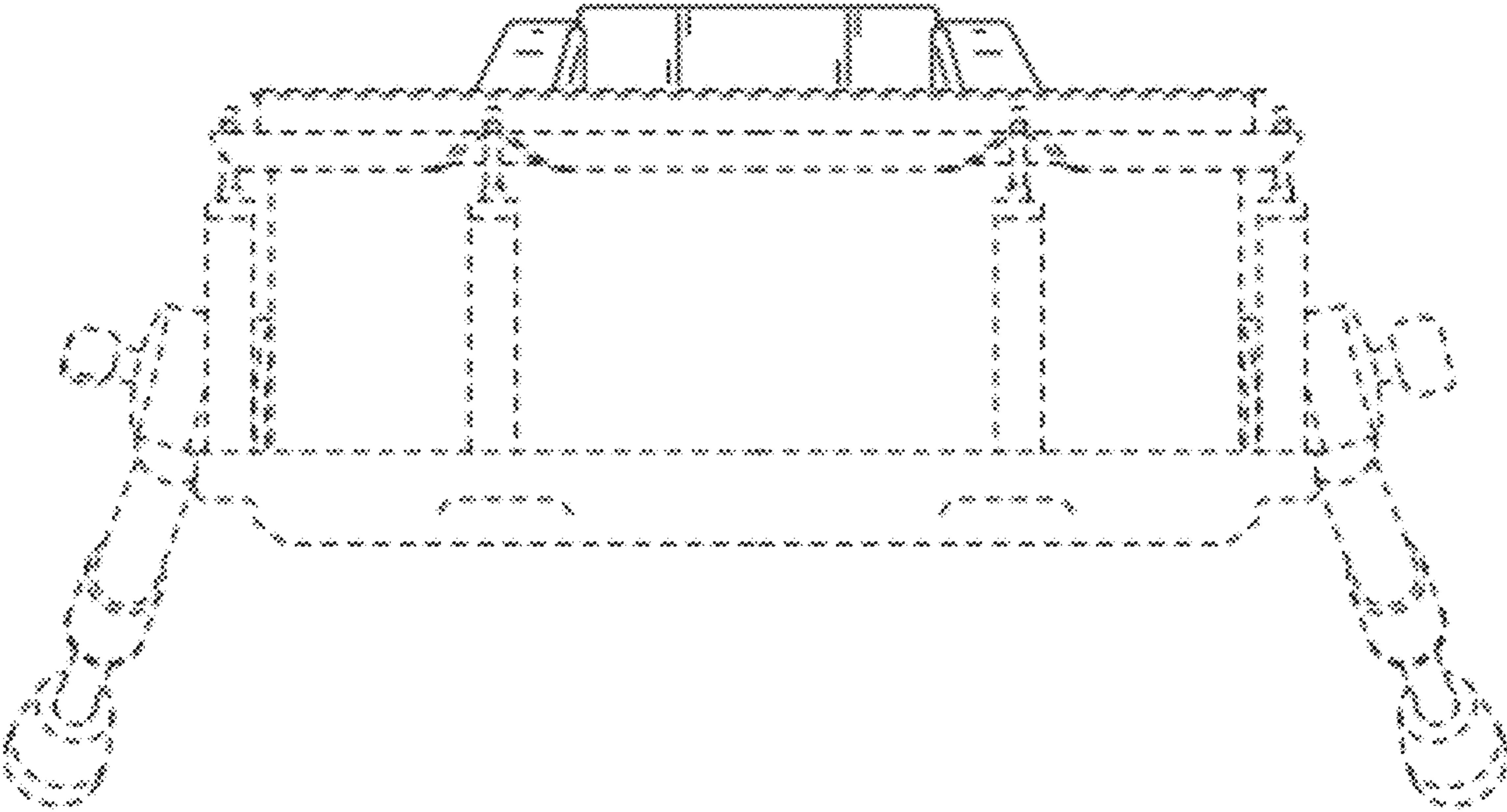

FIG. 5

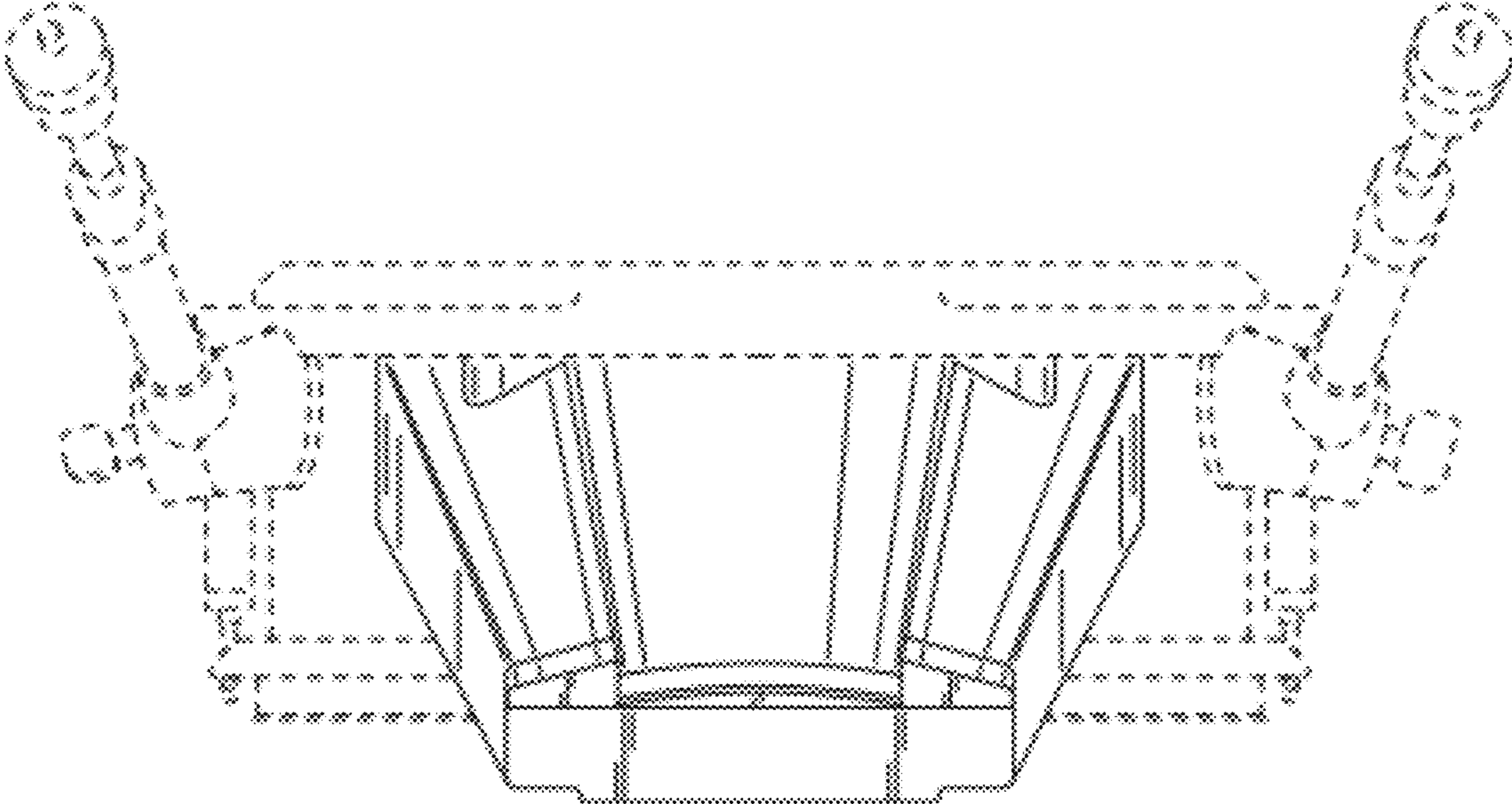

FIG. 6

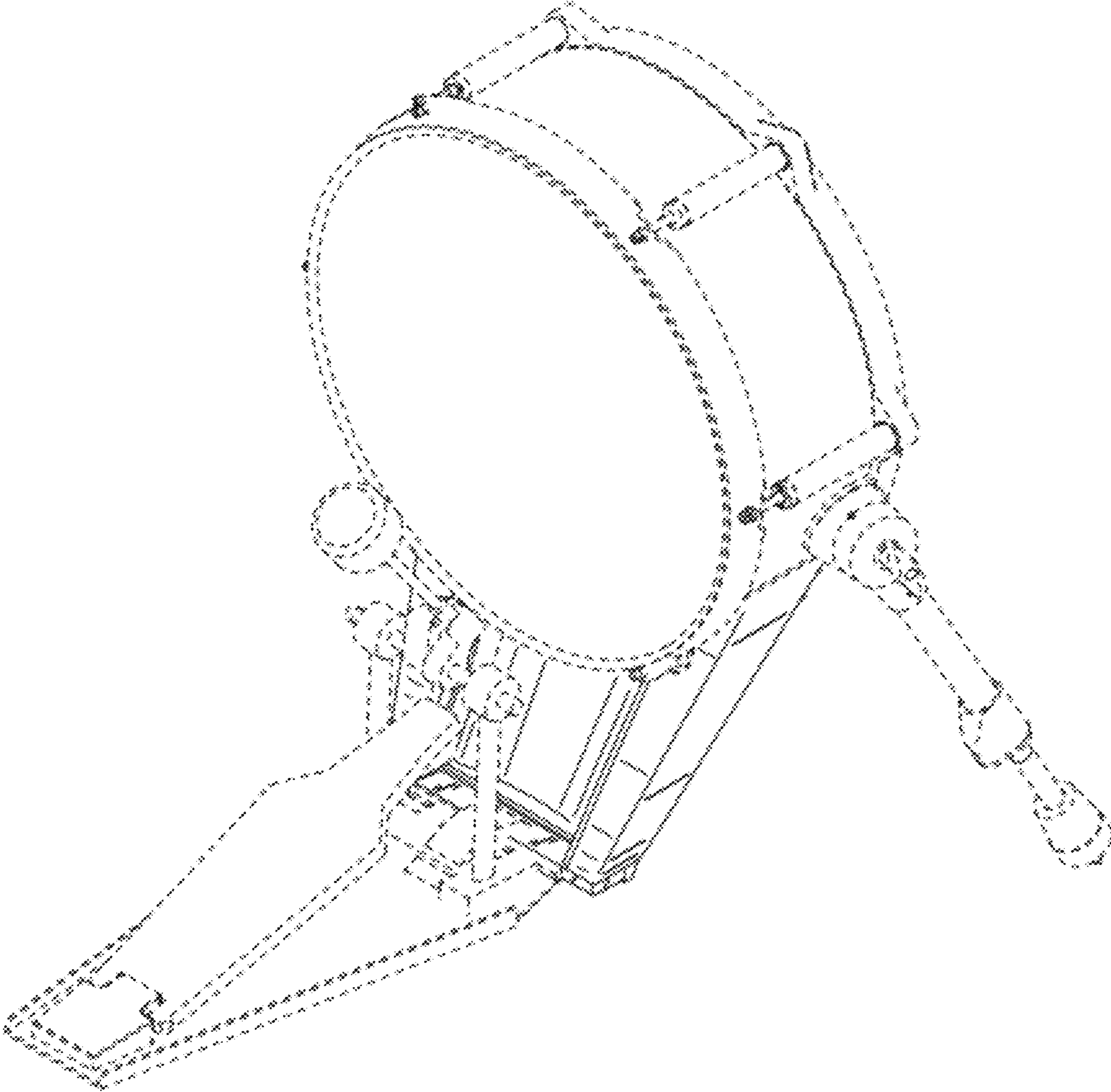

FIG. 7



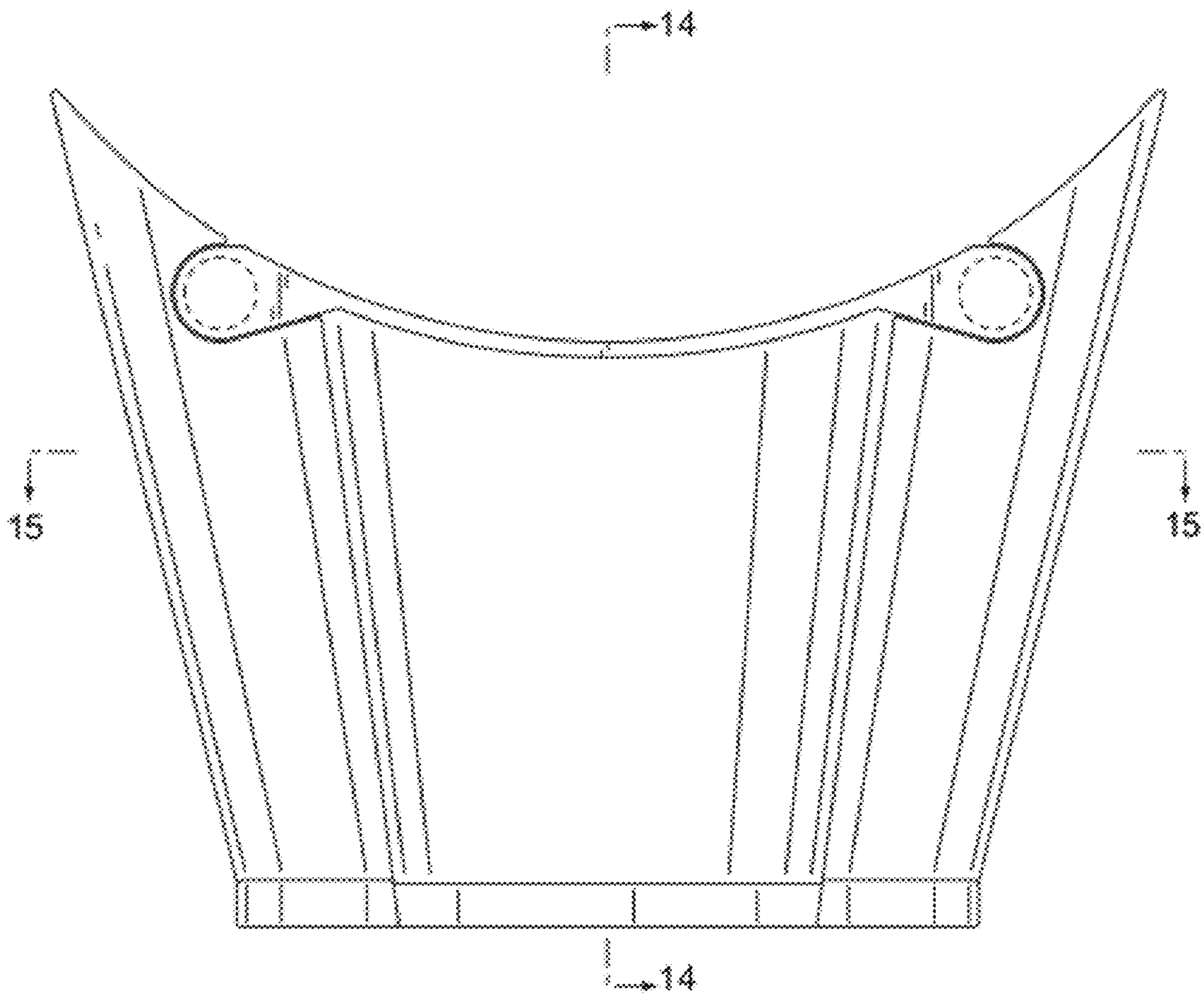

FIG. 8

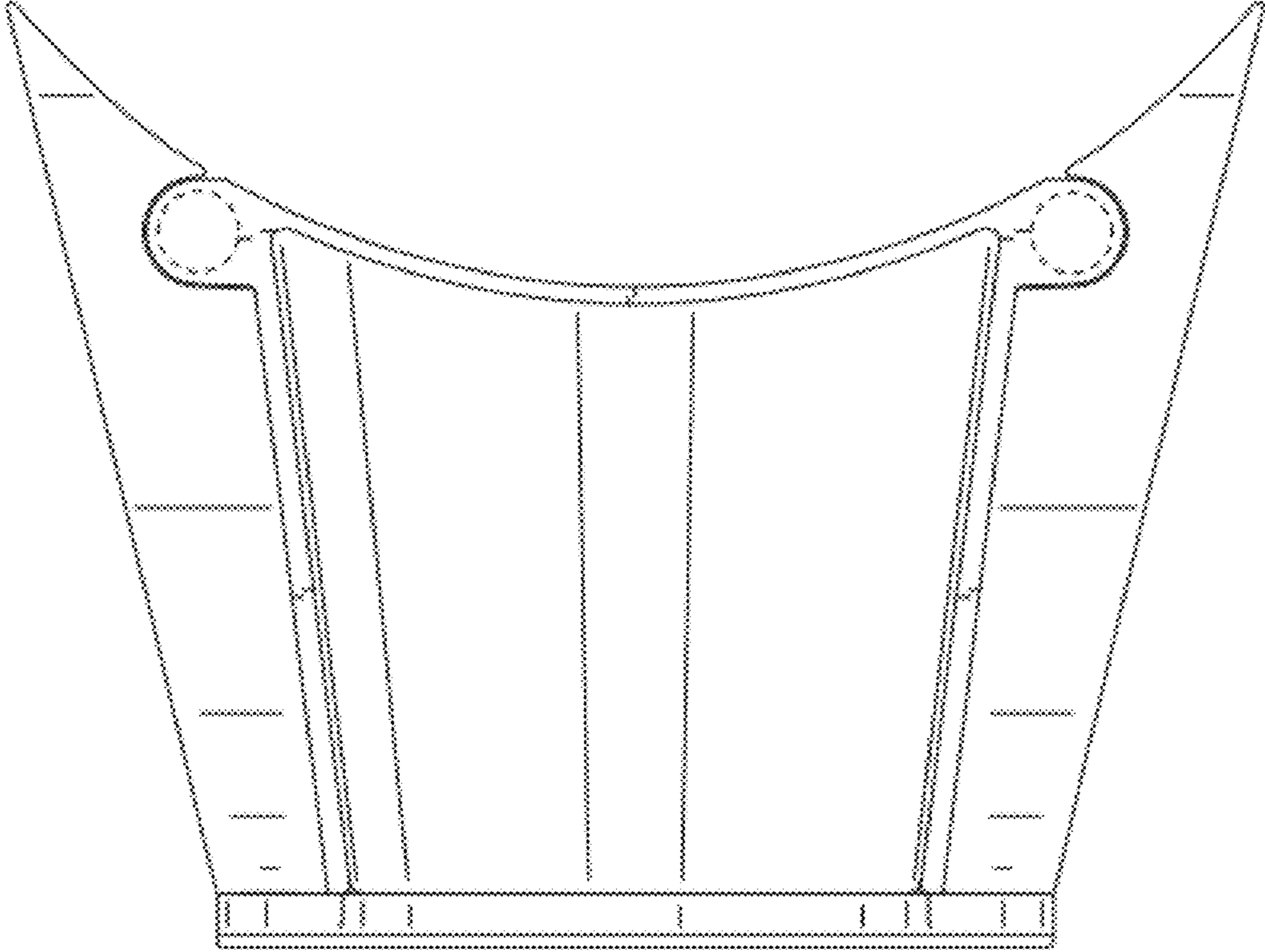

FIG. 9

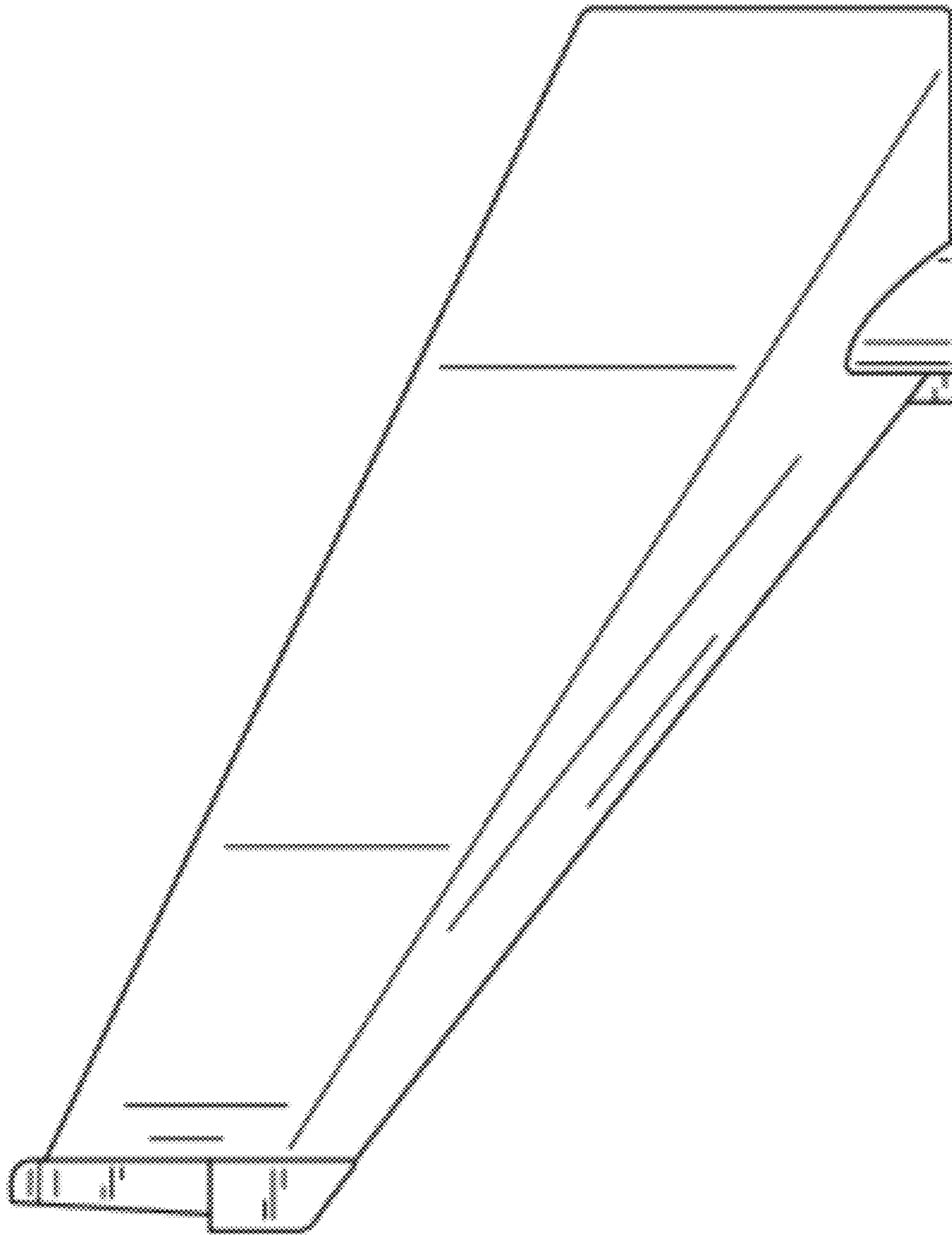

FIG. 10

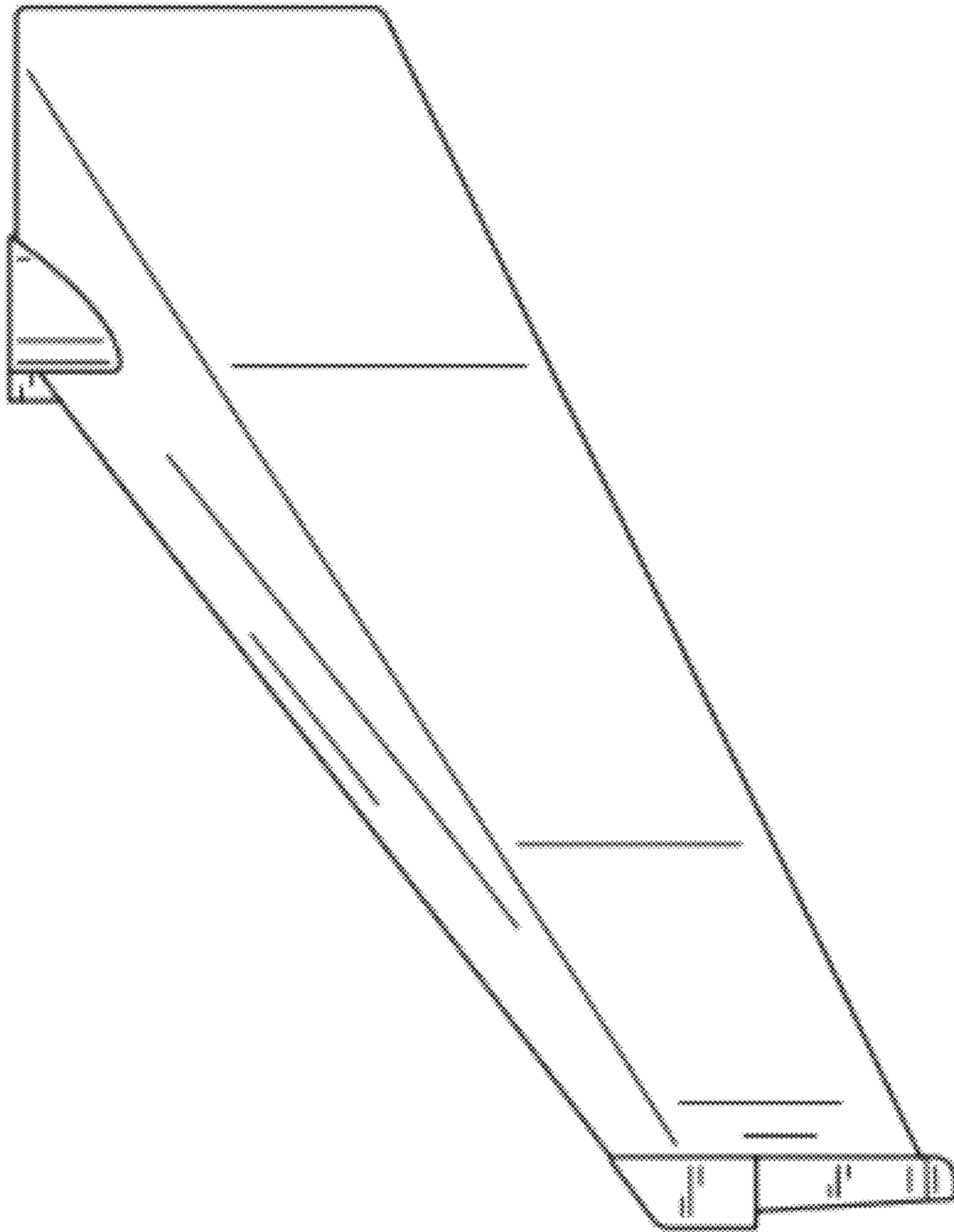

FIG. 11



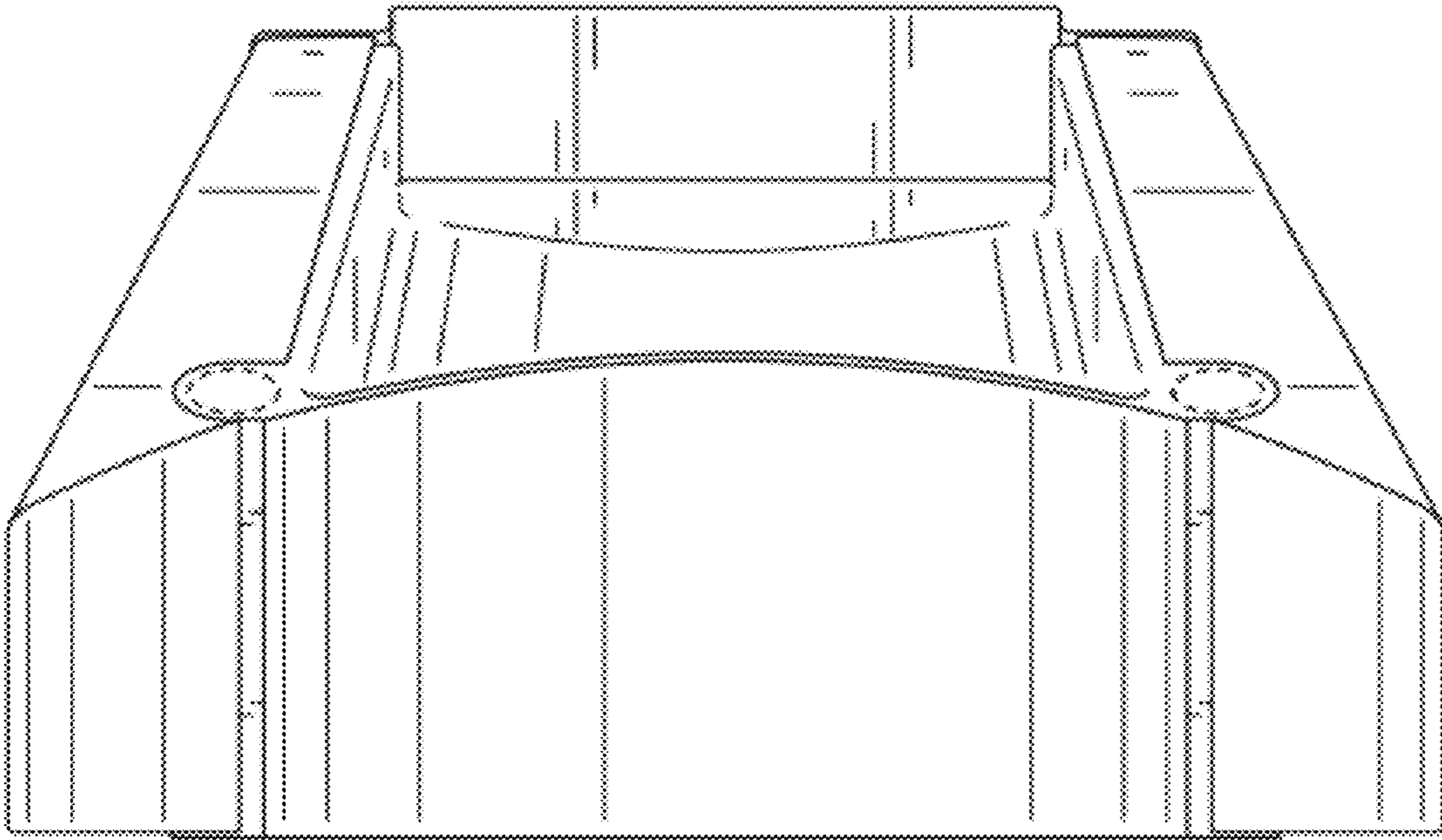

FIG . 12

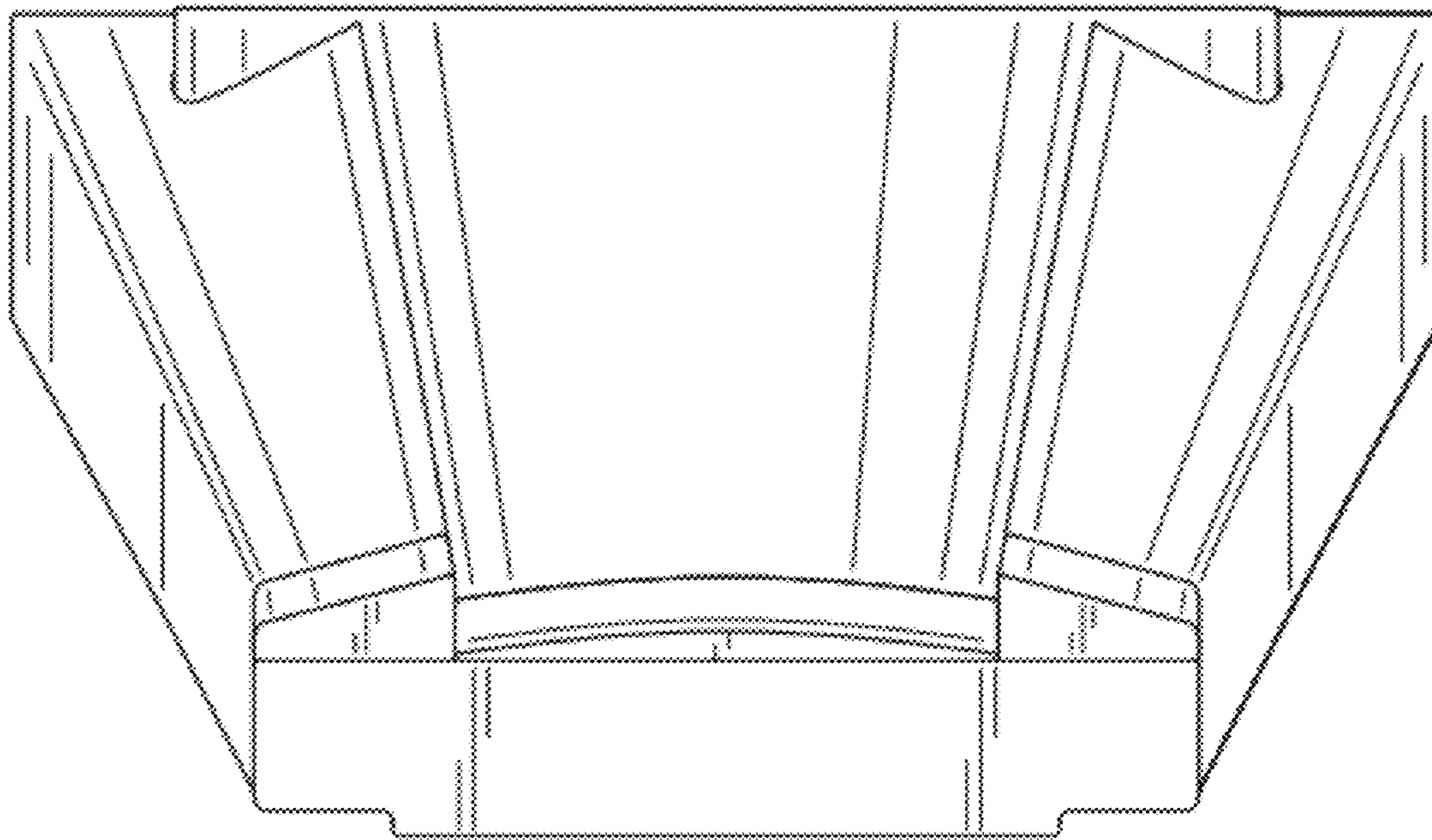

FIG . 13

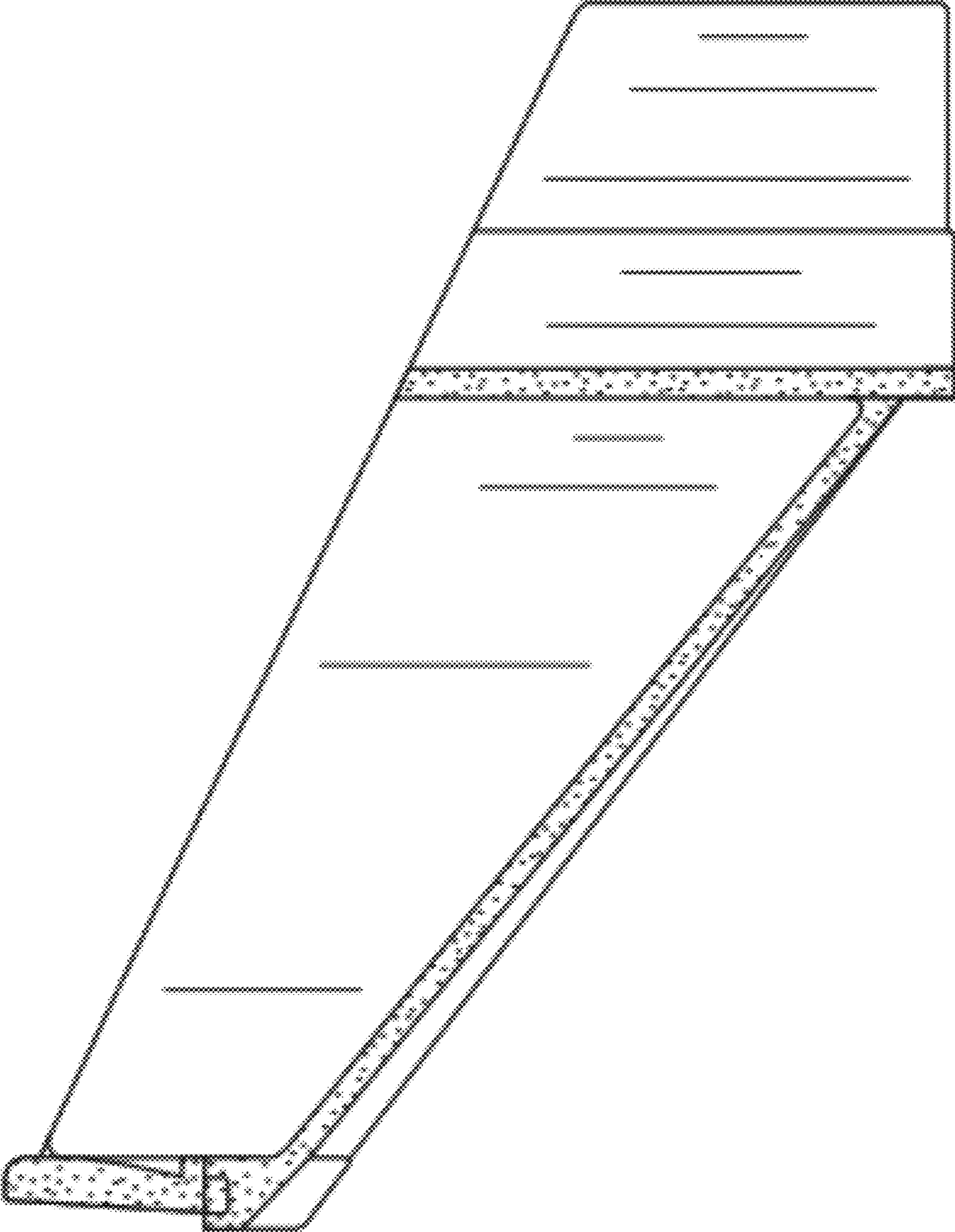

FIG. 14

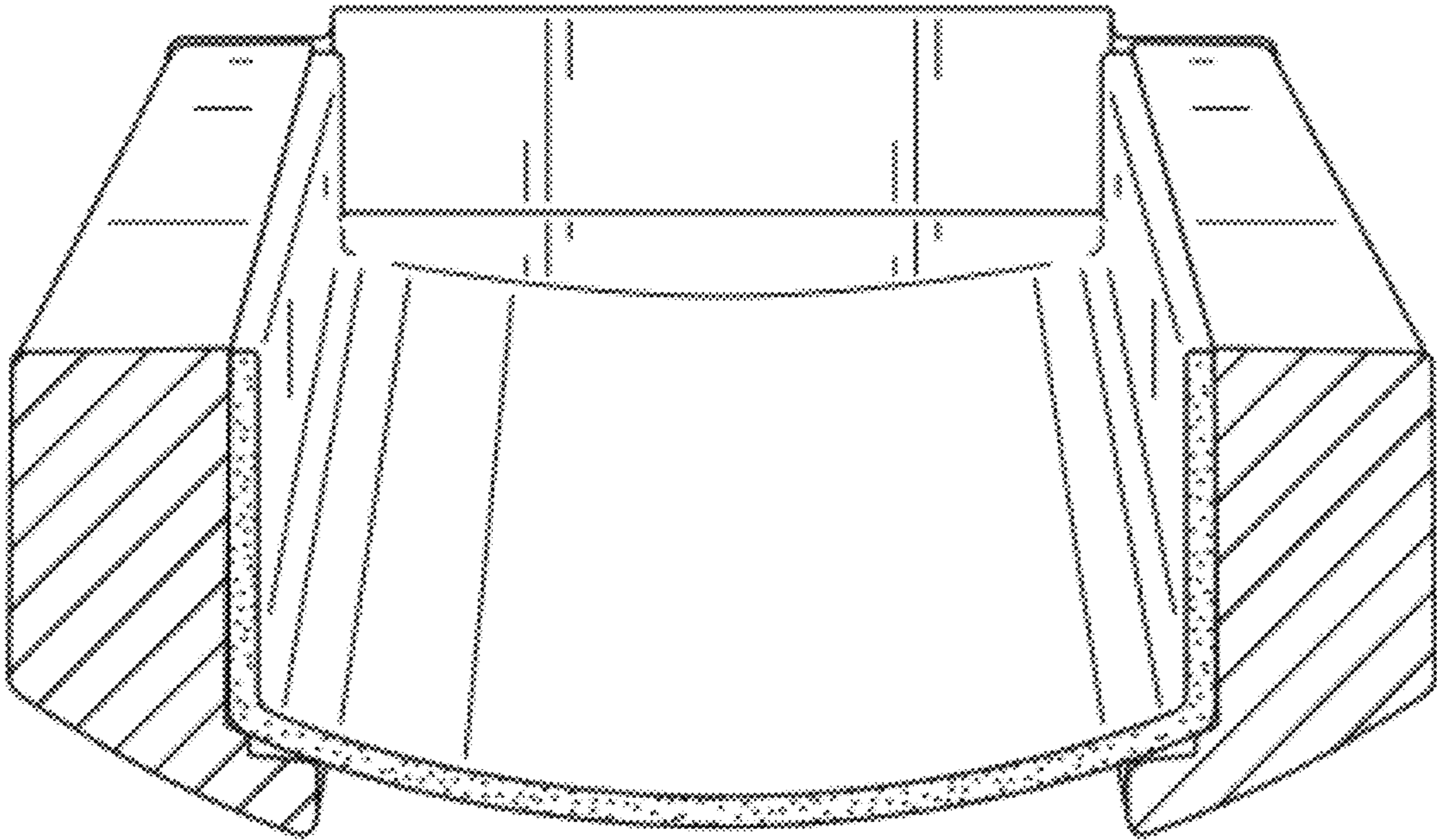

FIG. 15