



US00D670087S

(12) **United States Design Patent**  
**Walker**

(10) **Patent No.:** **US D670,087 S**  
(45) **Date of Patent:** **\*\* Nov. 6, 2012**

(54) **MIRRORED CLIP**

(76) Inventor: **Gary K. Walker**, Arvada, CO (US)

(\*\*) Term: **14 Years**

(21) Appl. No.: **29/412,428**

(22) Filed: **Feb. 2, 2012**

(51) **LOC (9) Cl.** ..... **06-07**

(52) **U.S. Cl.** ..... **D6/309**

(58) **Field of Classification Search** ..... D6/300-314;  
D12/189; D26/140; D24/107; D16/135;  
D20/42

See application file for complete search history.

(56) **References Cited**

**U.S. PATENT DOCUMENTS**

D284,462 S *	7/1986	Greenlaw et al. ....	D12/189
D286,395 S *	10/1986	Greenlaw et al. ....	D12/189
D331,967 S *	12/1992	Flower .....	D24/107
D358,715 S *	5/1995	Young .....	D6/300
D377,421 S *	1/1997	Young .....	D6/300
D378,159 S *	2/1997	Mulkey .....	D2/896
D405,039 S *	2/1999	Kiser .....	D12/189
D614,219 S *	4/2010	Yip et al. ....	D16/135

D657,425 S \* 4/2012 Podd ..... D20/42

\* cited by examiner

*Primary Examiner* — Philip S Hyder

*Assistant Examiner* — Sydney Buffalow

(74) *Attorney, Agent, or Firm* — Aileen Law; A Law Firm, PC

(57) **CLAIM**

The ornamental design for a mirrored clip, as shown and described.

**DESCRIPTION**

FIG. 1 is a front elevational view of my new design for a mirrored clip;

FIG. 2 is a back elevational view of FIG. 1;

FIG. 3 is a right side elevational view of FIG. 1;

FIG. 4 is a left side elevational view of FIG. 1;

FIG. 5 is a top plan view of the embodiment shown in FIG. 1.

FIG. 6 is a bottom plan view thereof; and,

FIG. 7 is a top, front and left perspective view thereof.

The broken lines shown in the drawings illustrate environment and form no part of the claimed design.

**1 Claim, 2 Drawing Sheets**

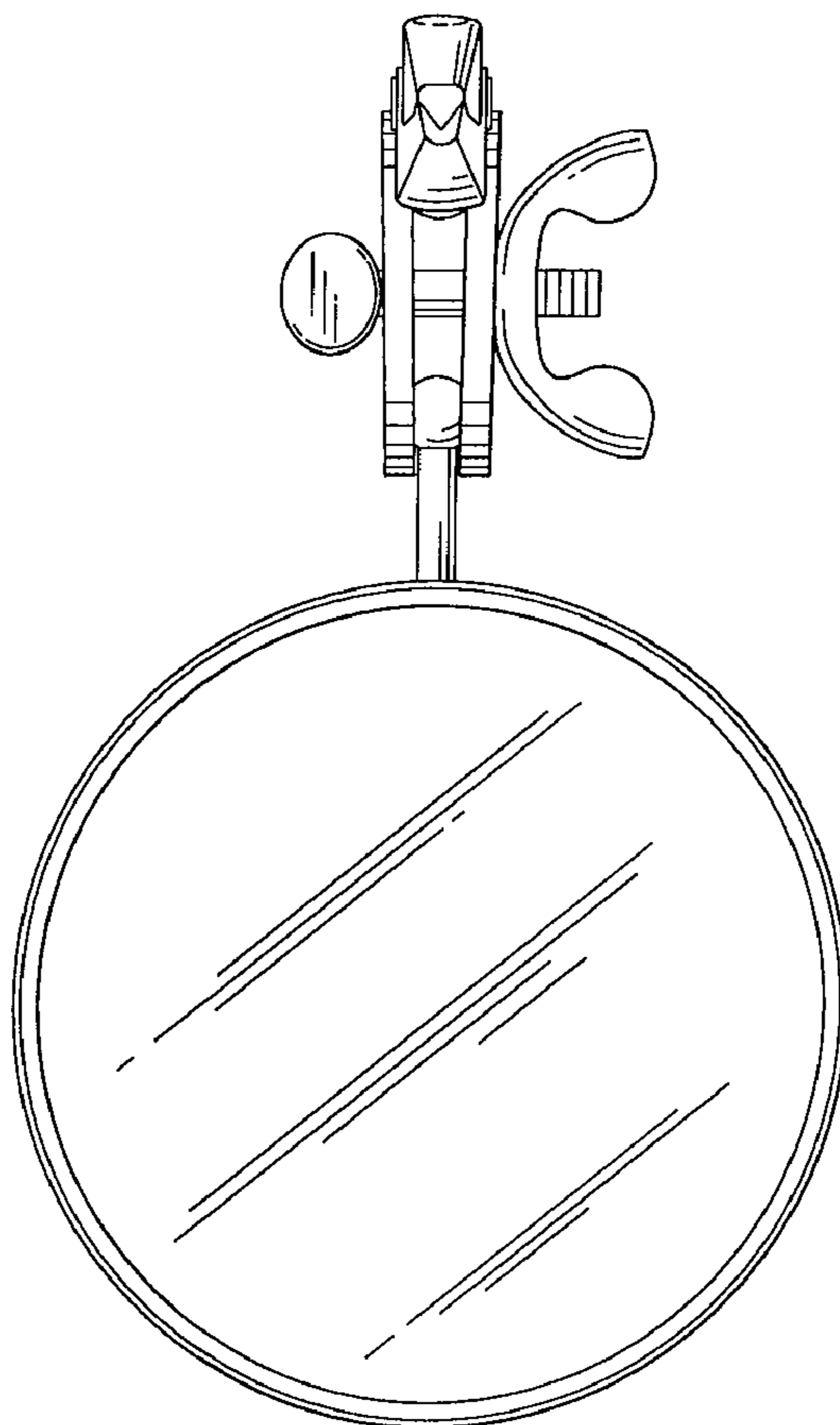

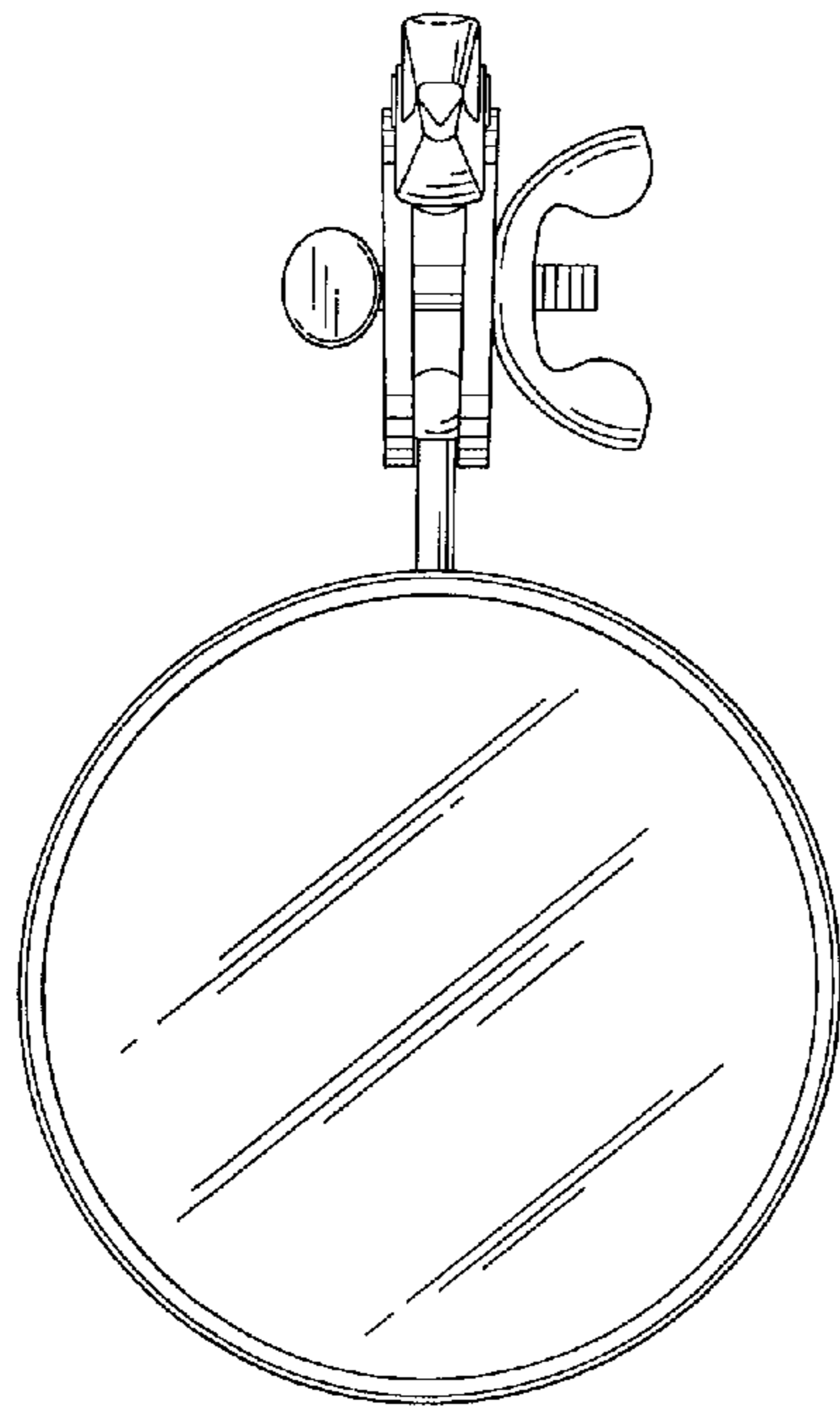

FIG. 1

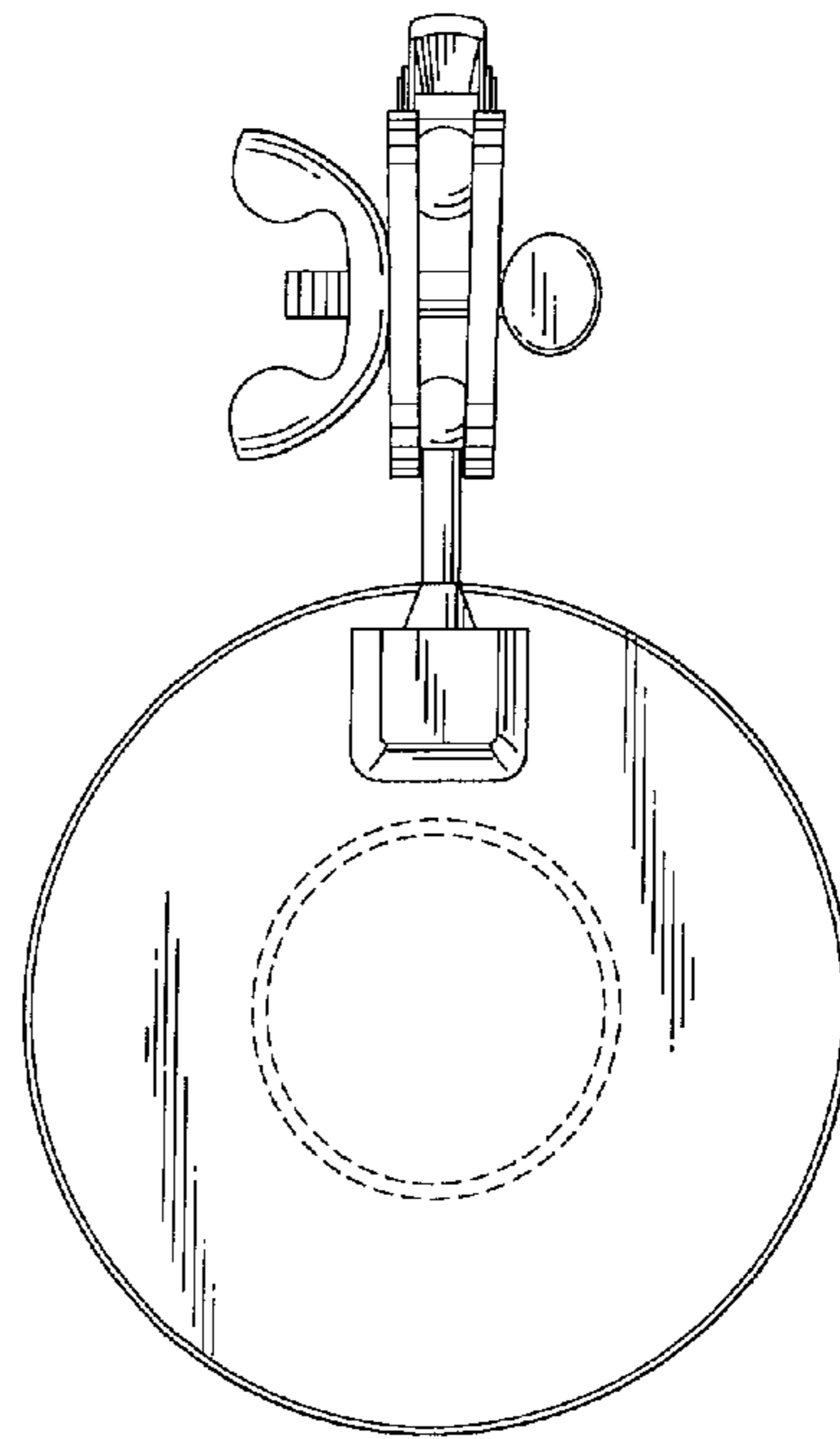

FIG. 2

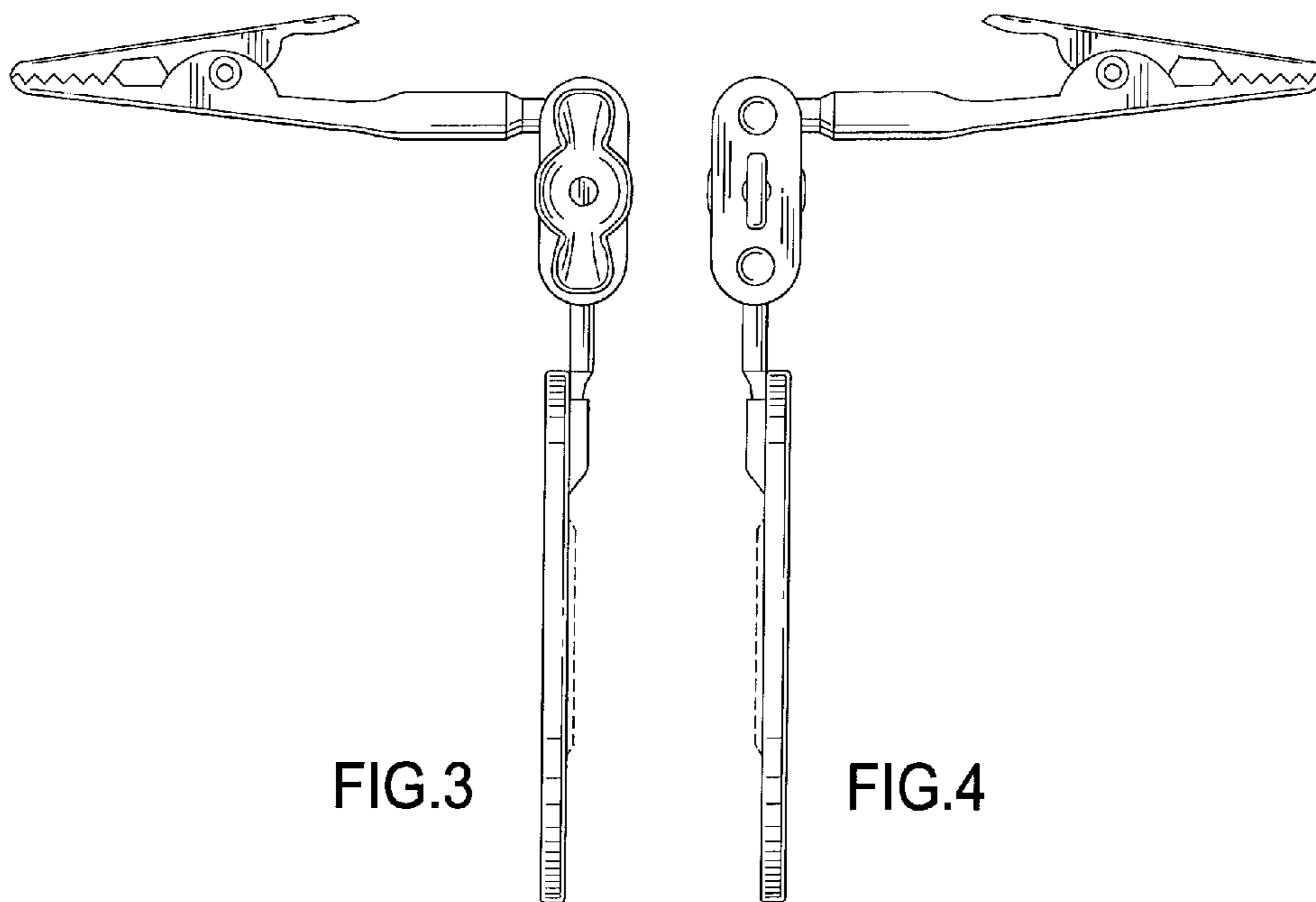

FIG. 3

FIG. 4

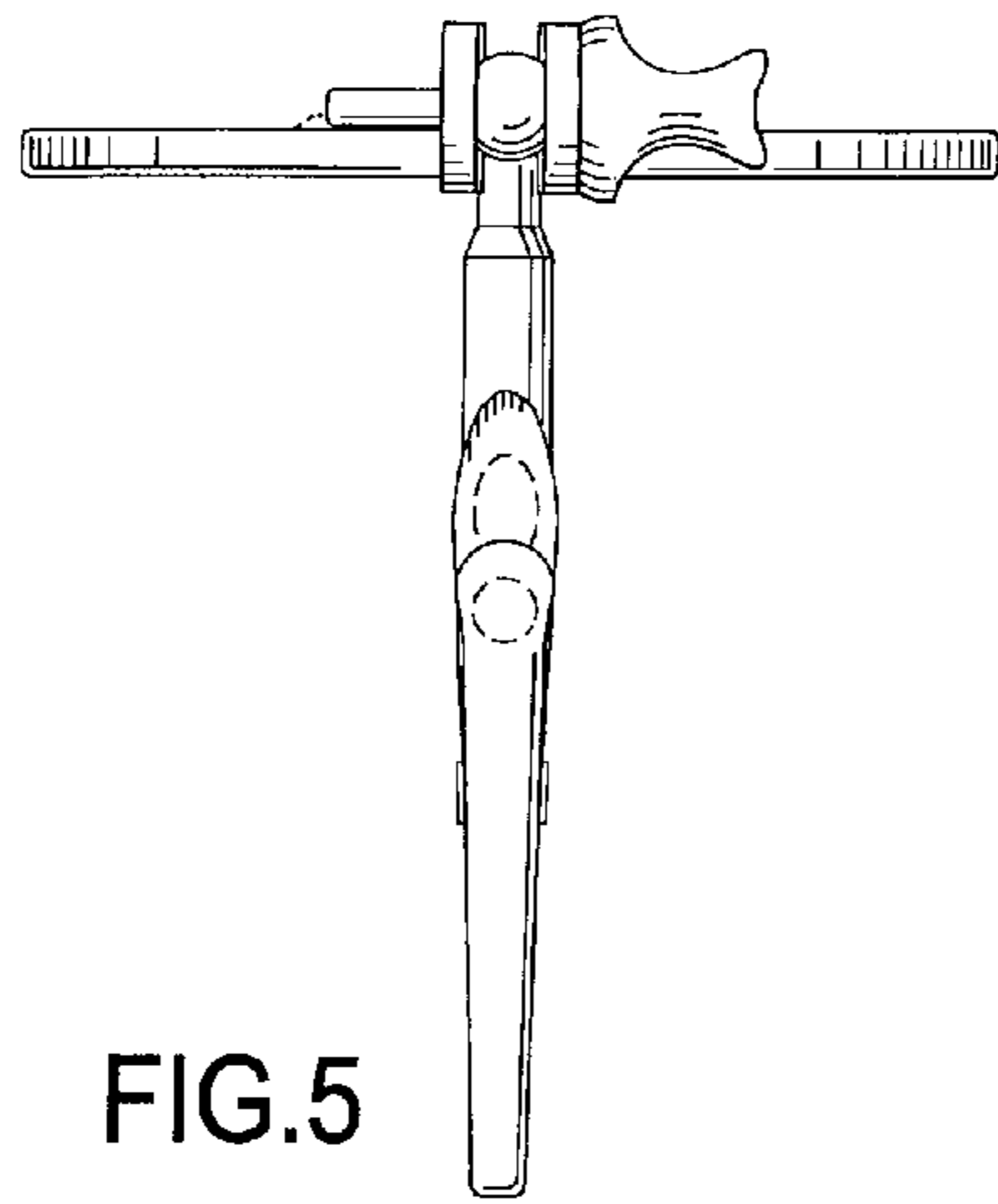

FIG. 5

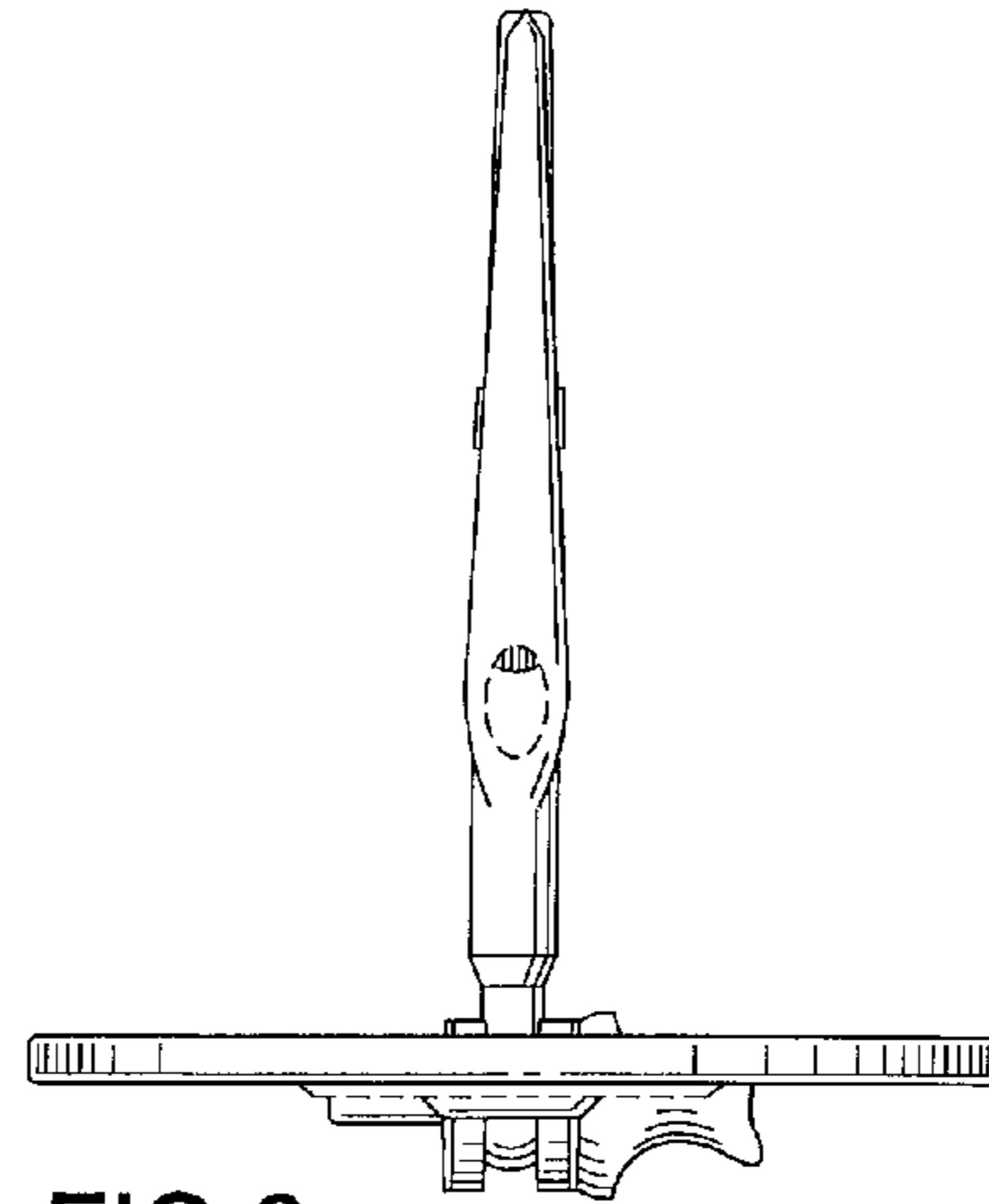

FIG. 6

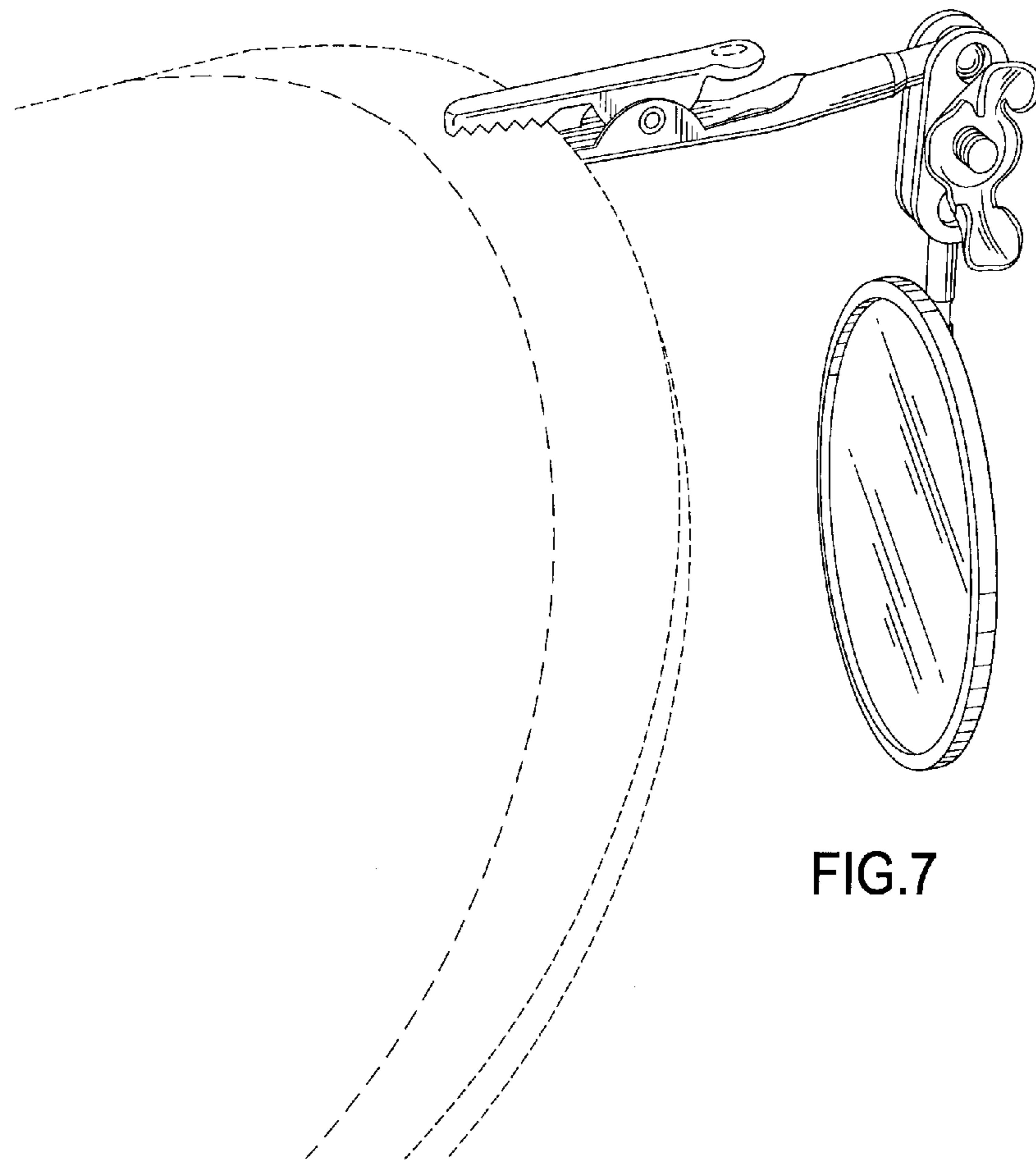

FIG. 7