

US00D669821S

(12) **United States Design Patent**  
**Nishihara et al.**

(10) **Patent No.:** **US D669,821 S**

(45) **Date of Patent:** **\*\* Oct. 30, 2012**

(54) **MOTORCYCLE**

D638,756 S \* 5/2011 Kouchi et al. .... D12/110  
D647,825 S \* 11/2011 Shibuta et al. .... D12/110

(75) Inventors: **Toshiyuki Nishihara**, Kakogawa (JP);  
**Takumi Uemoto**, Kobe (JP)

\* cited by examiner

(73) Assignee: **Kawasaki Jukogyo Kabushiki Kaisha**,  
Hyogo (JP)

*Primary Examiner* — Susan M Lee

*Assistant Examiner* — Linda G. Brooks

(\*\*) Term: **14 Years**

(21) Appl. No.: **29/395,700**

(22) Filed: **Mar. 13, 2012**

(30) **Foreign Application Priority Data**

Sep. 21, 2011 (JP) ..... 2011-021528

(51) **LOC (9) Cl.** ..... **12-11**

(52) **U.S. Cl.** ..... **D12/110**

(58) **Field of Classification Search** ..... D12/110;  
180/219, 220, 225, 229

See application file for complete search history.

(56) **References Cited**

**U.S. PATENT DOCUMENTS**

D588,961 S \* 3/2009 Tanaka et al. .... D12/110

D606,457 S \* 12/2009 Tanaka et al. .... D12/110

(57) **CLAIM**

The ornamental design for a motorcycle, as shown and described.

**DESCRIPTION**

FIG. 1 is a front elevational view of a motorcycle showing our new design;

FIG. 2 is a rear elevational view thereof;

FIG. 3 is a left side elevational view thereof;

FIG. 4 is a right side elevational view thereof;

FIG. 5 is a top plan view thereof;

FIG. 6 is a bottom plan view thereof;

FIG. 7 is a front left perspective view thereof; and,

FIG. 8 is a rear right perspective view thereof.

**1 Claim, 8 Drawing Sheets**

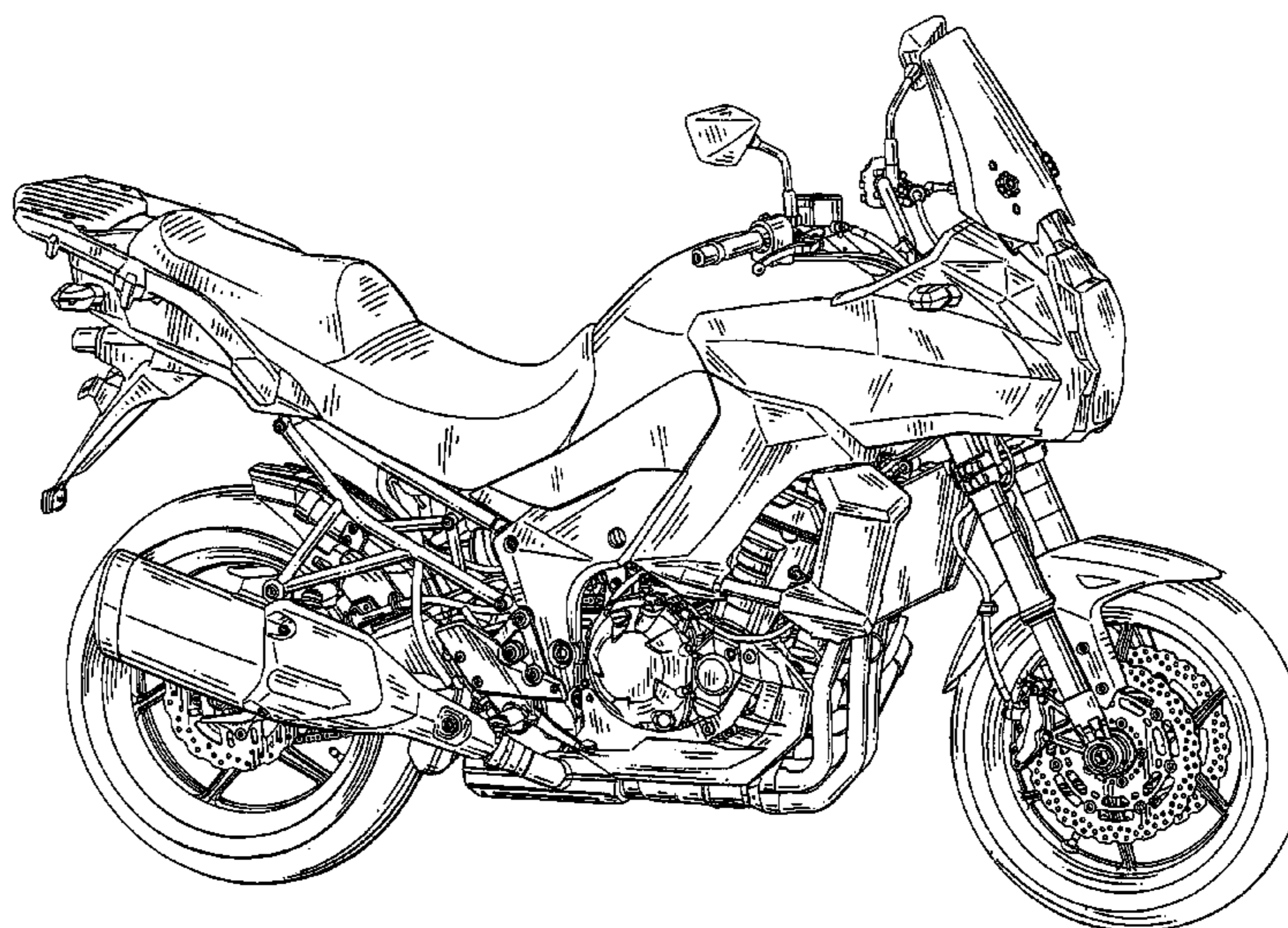
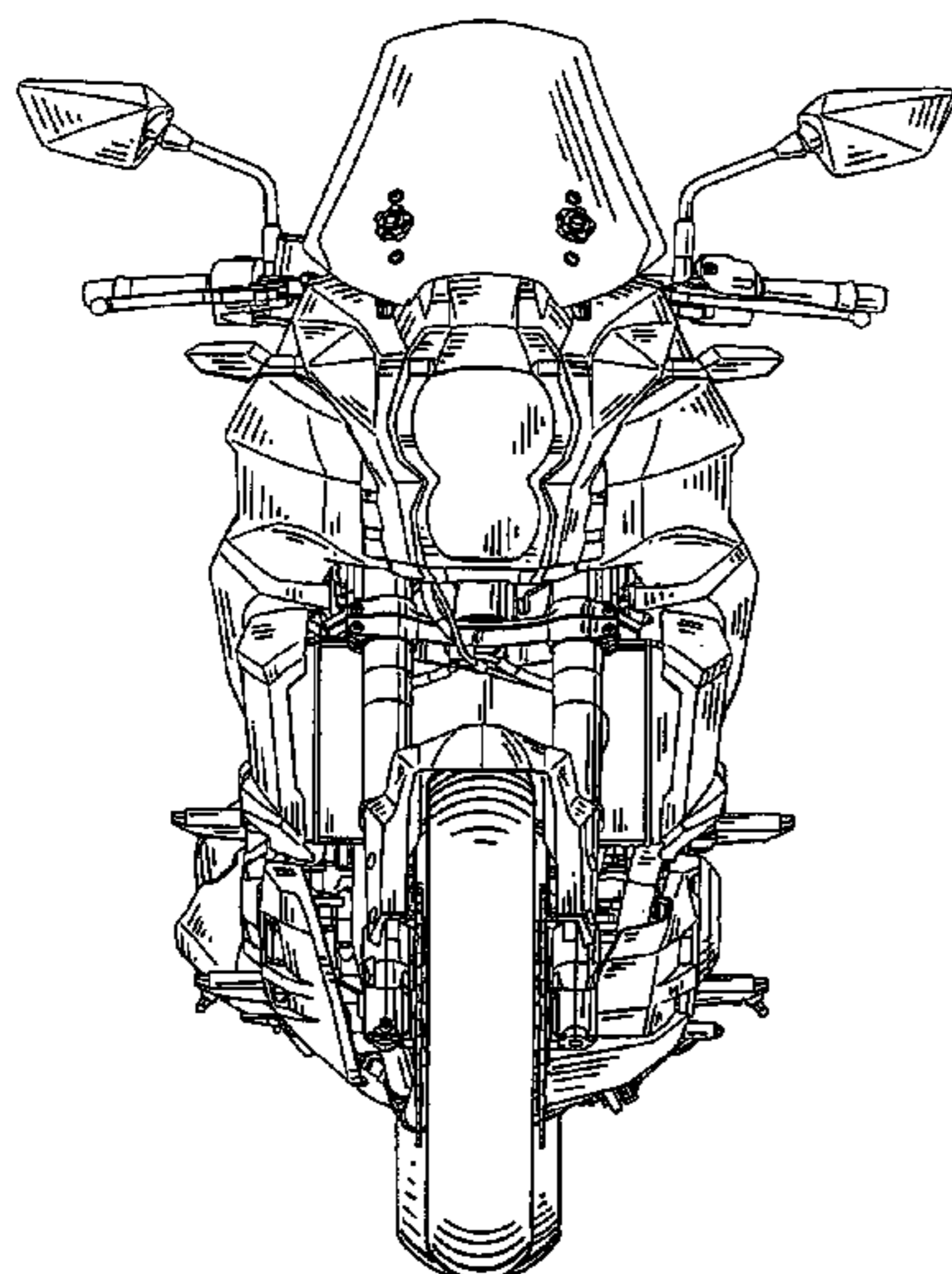

Fig. 1

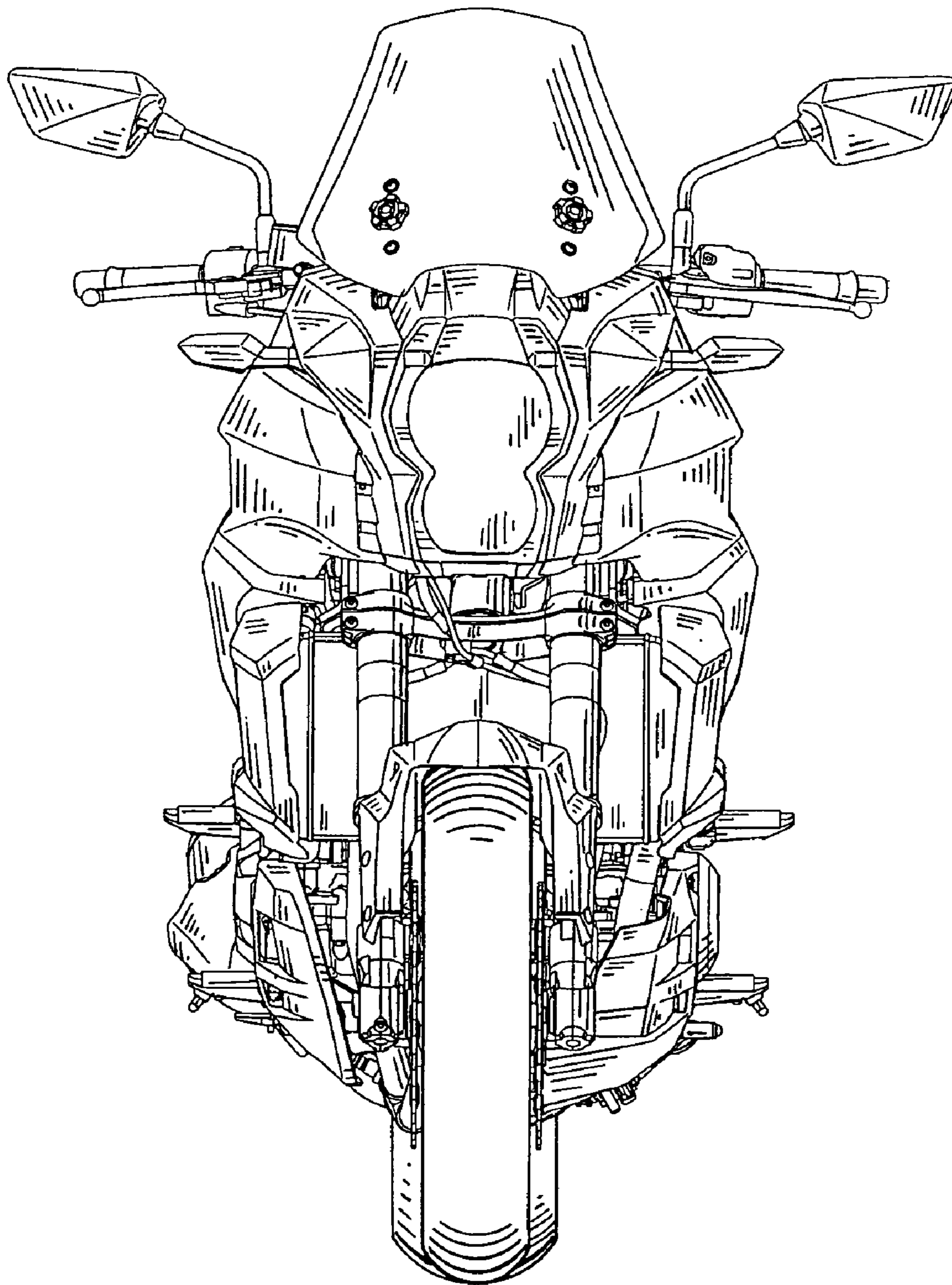
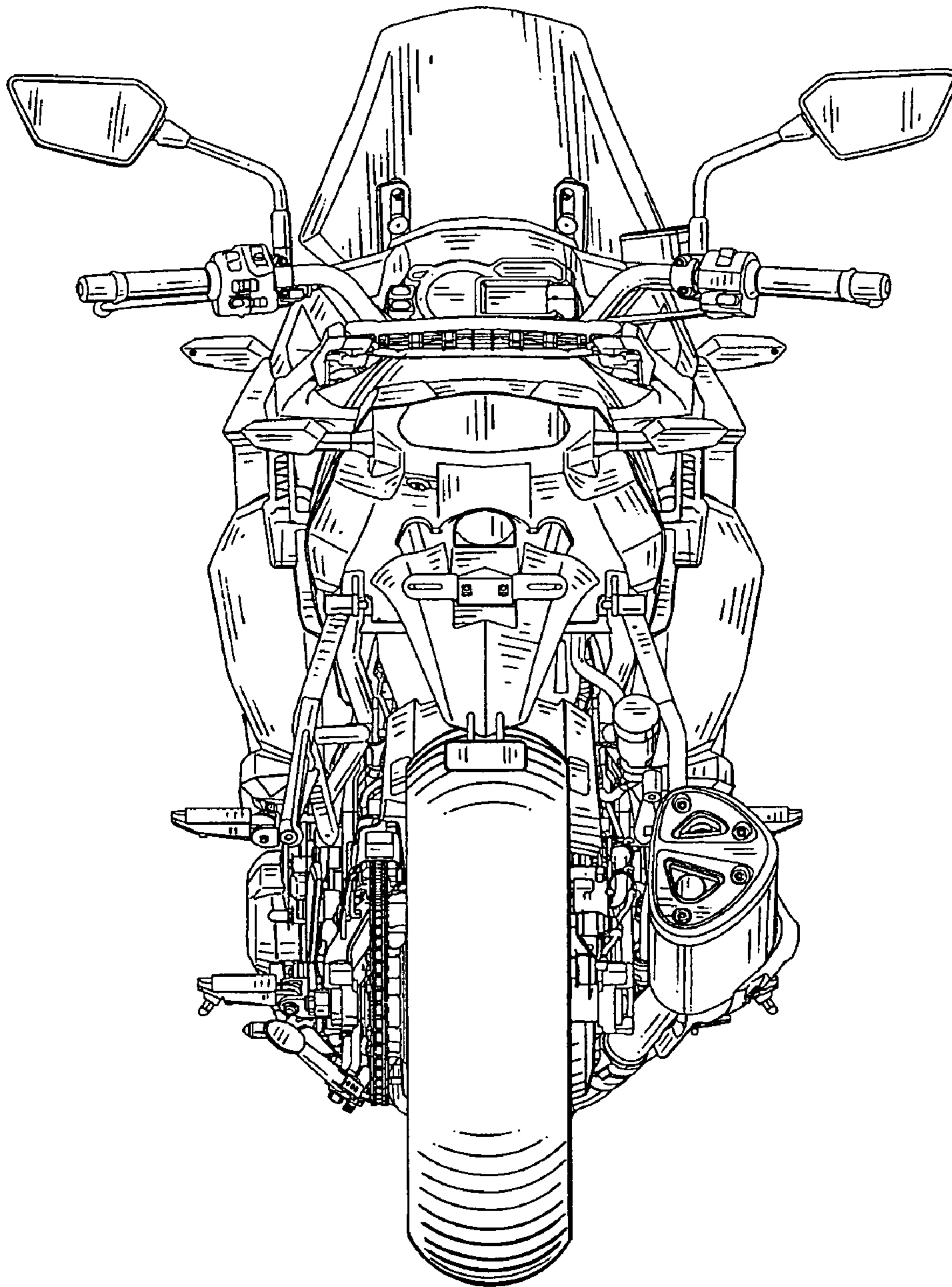

Fig. 2





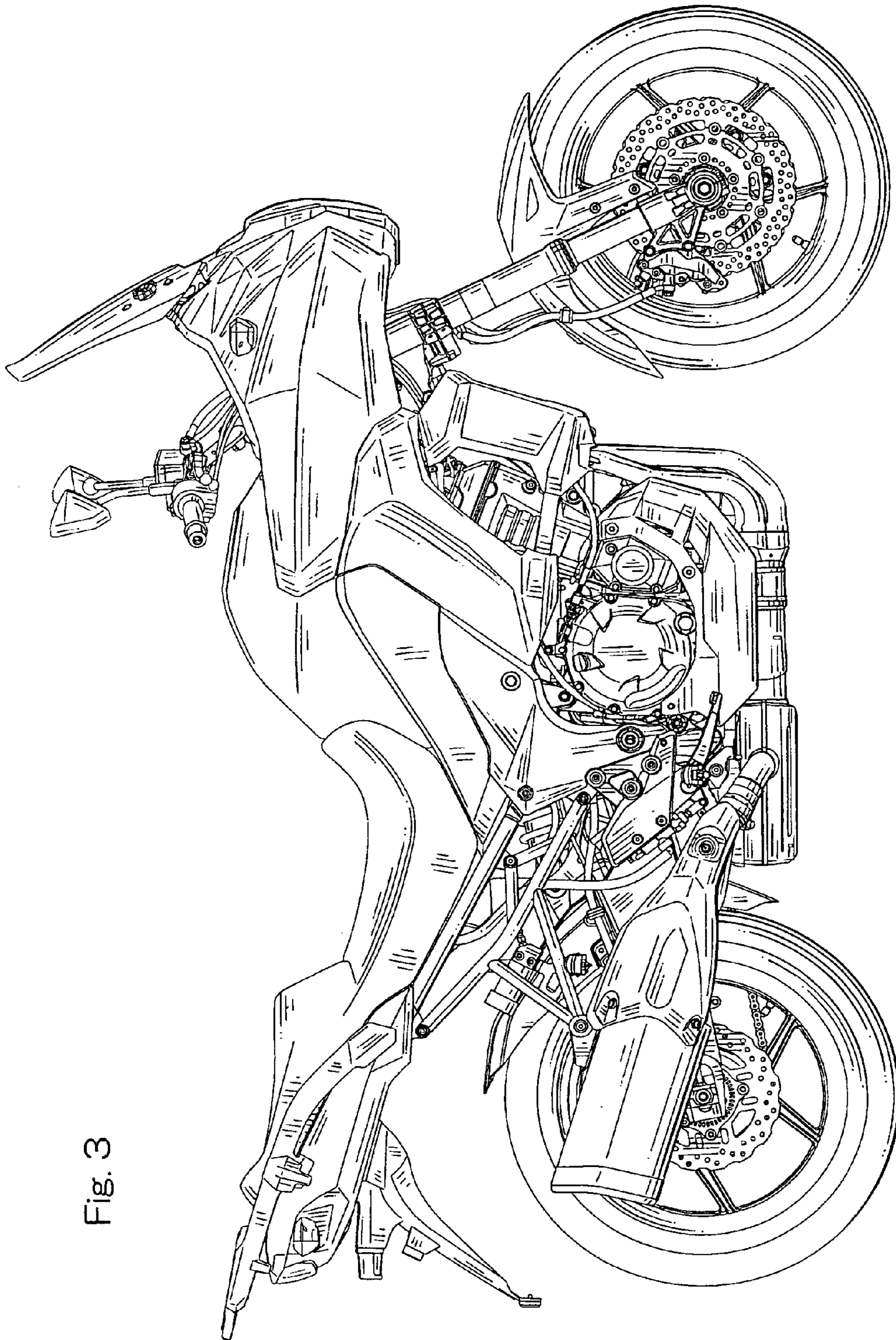

Fig. 3

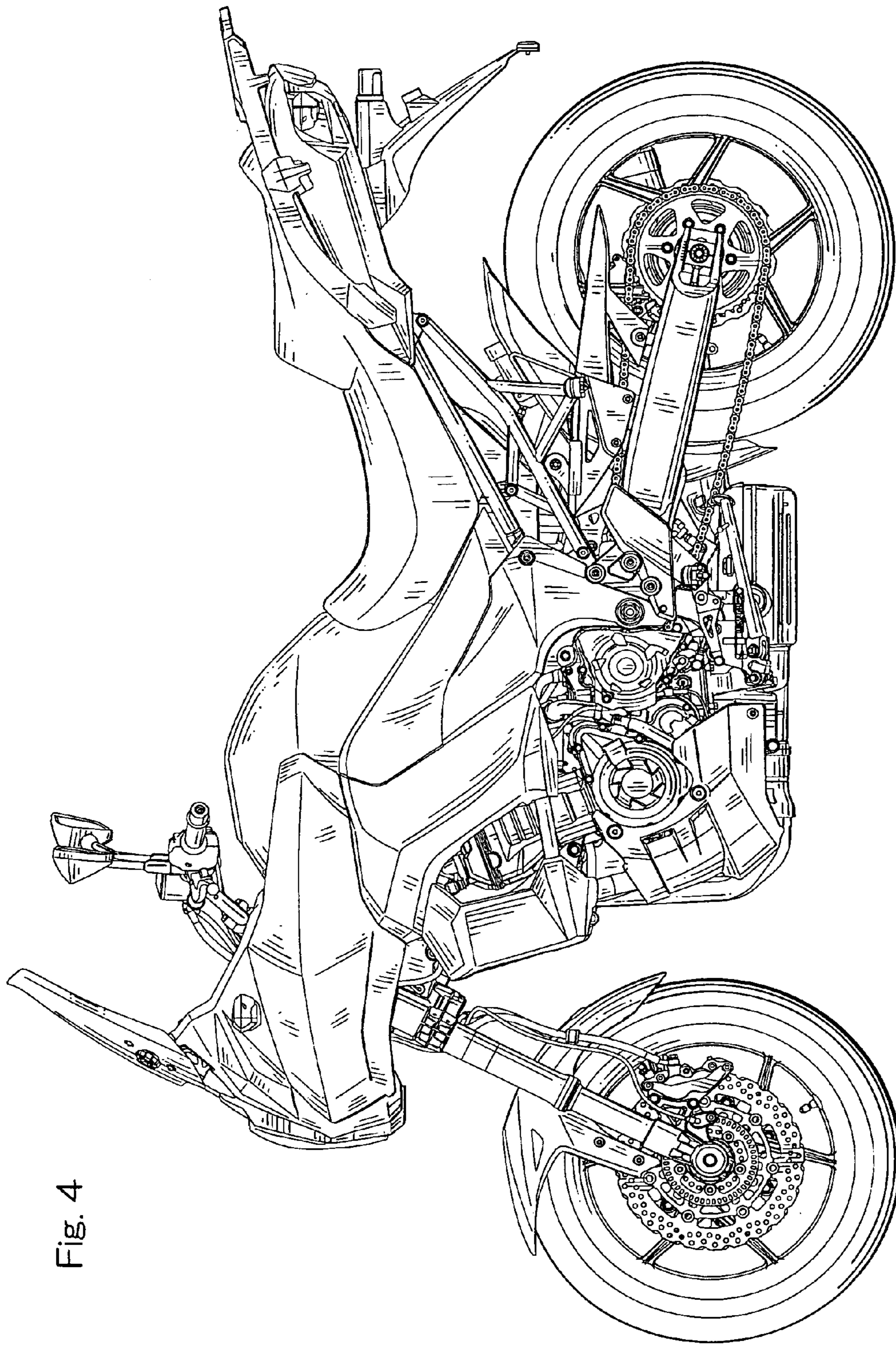

Fig. 4



Fig. 5

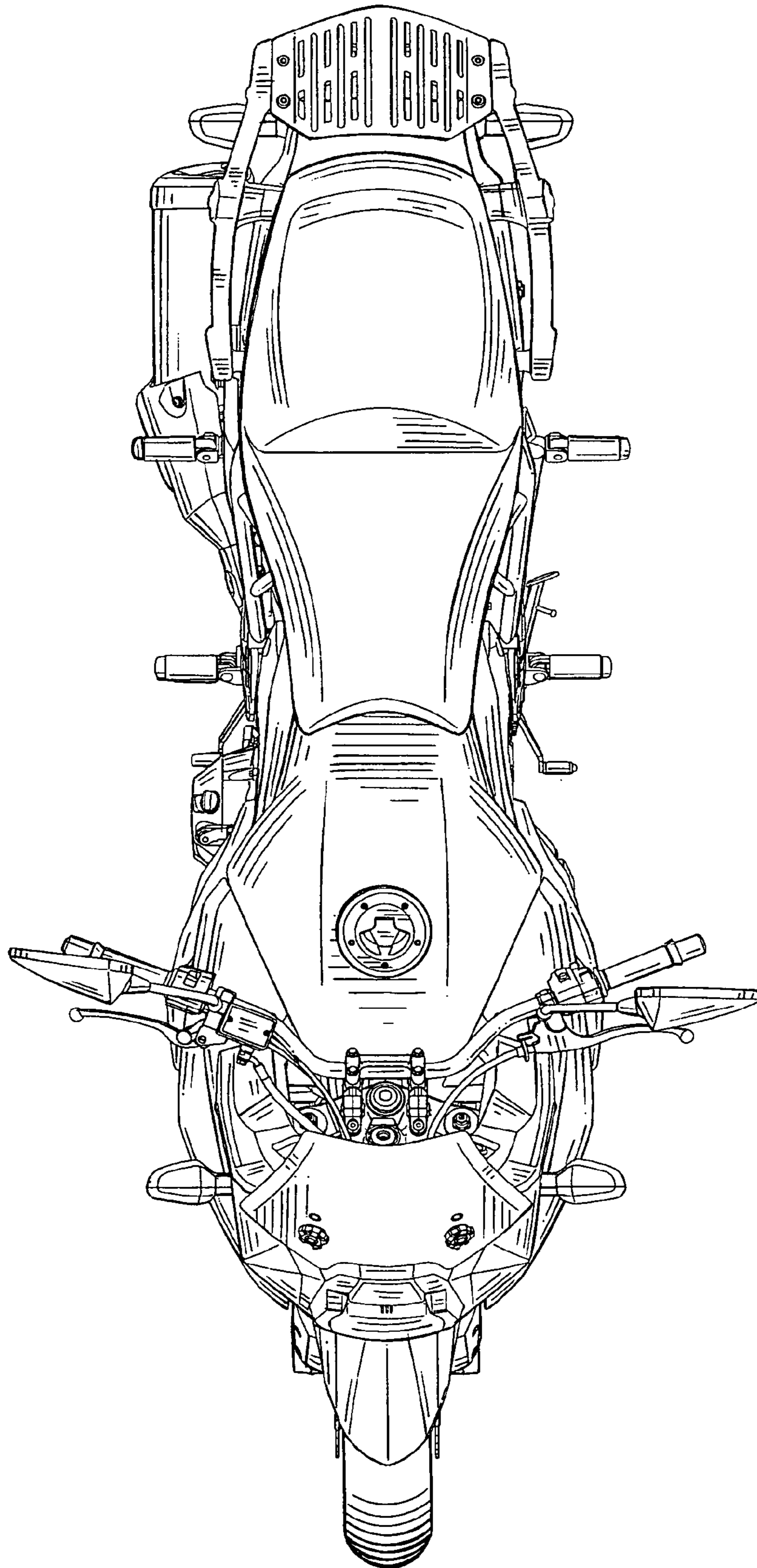
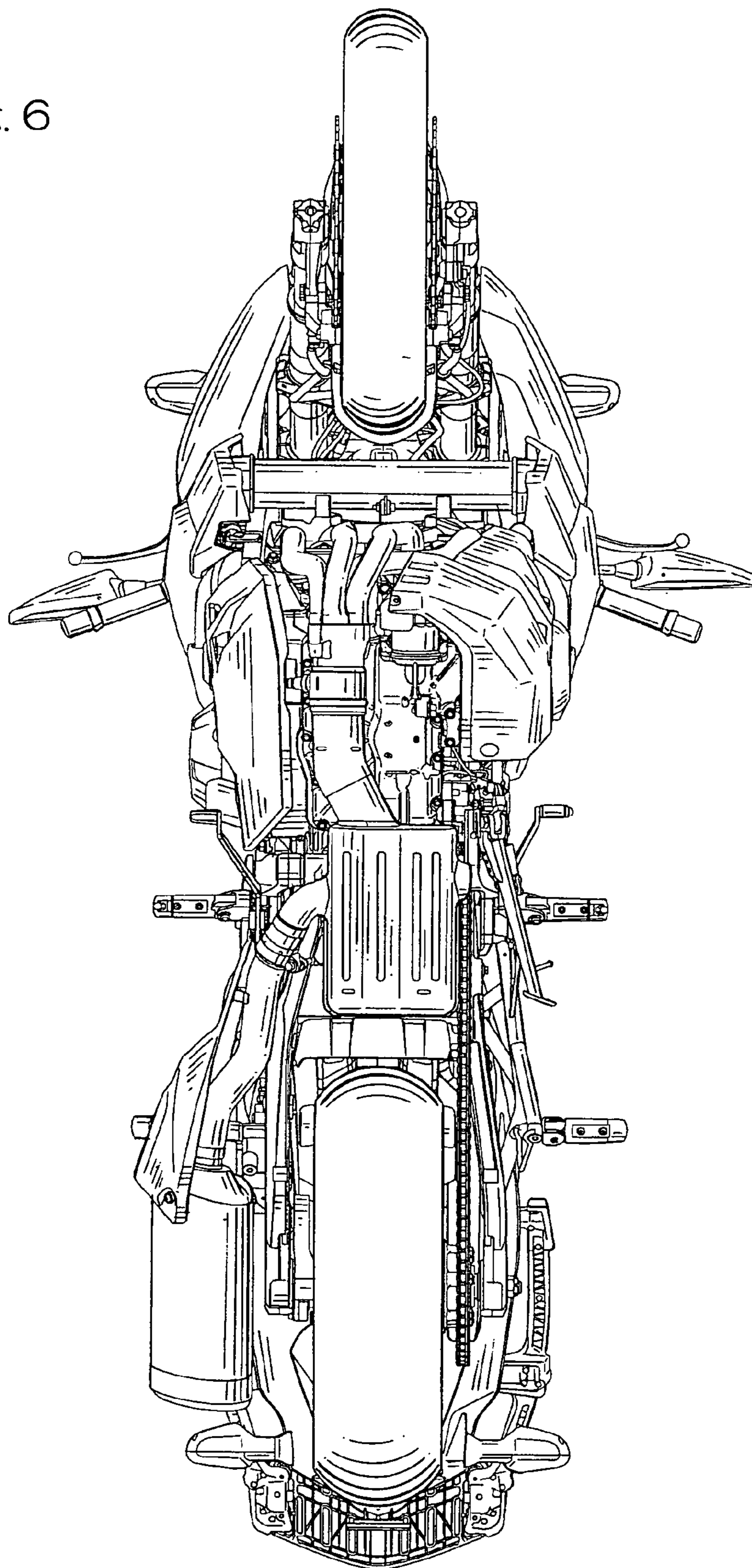

Fig. 6





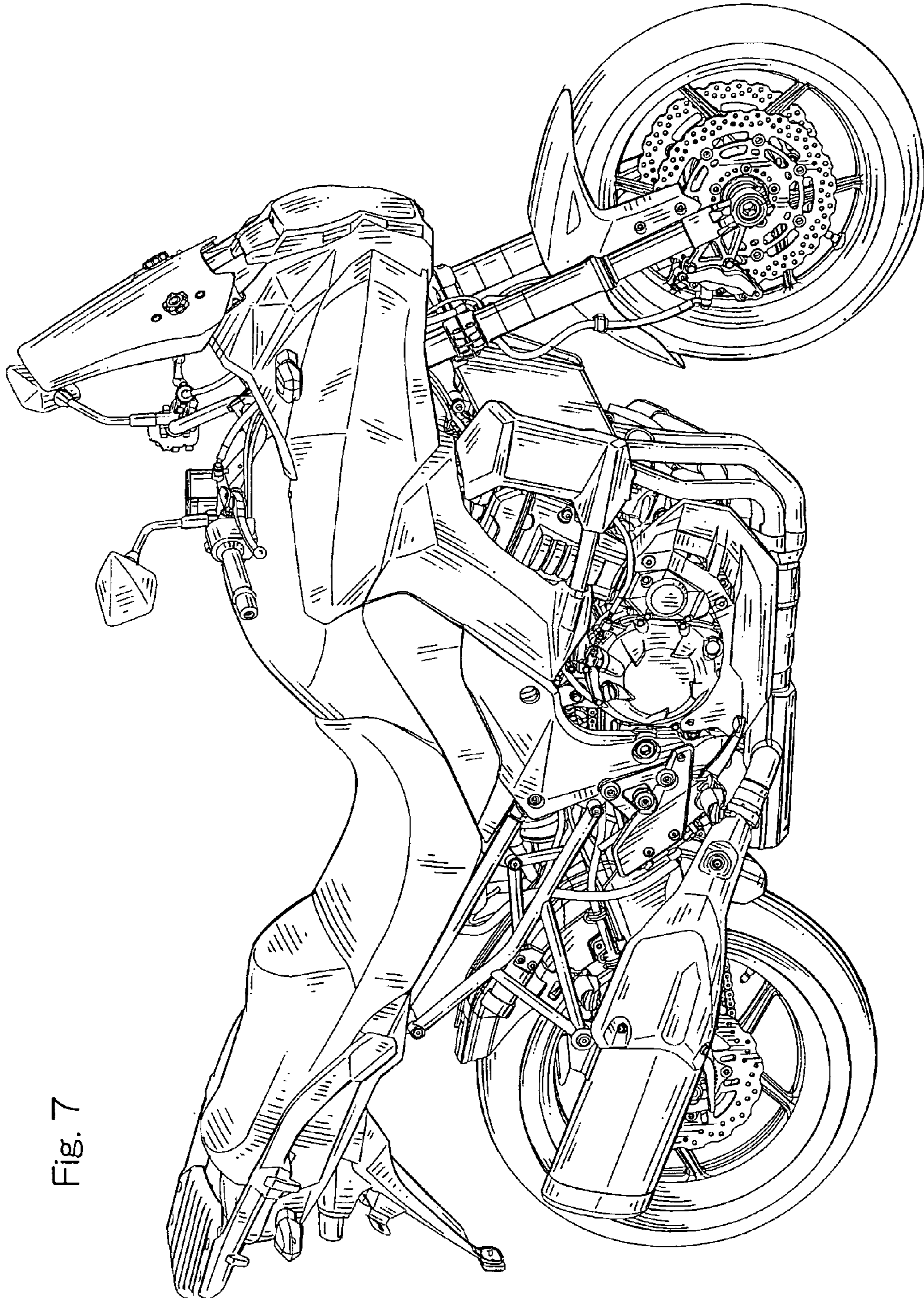

Fig. 7



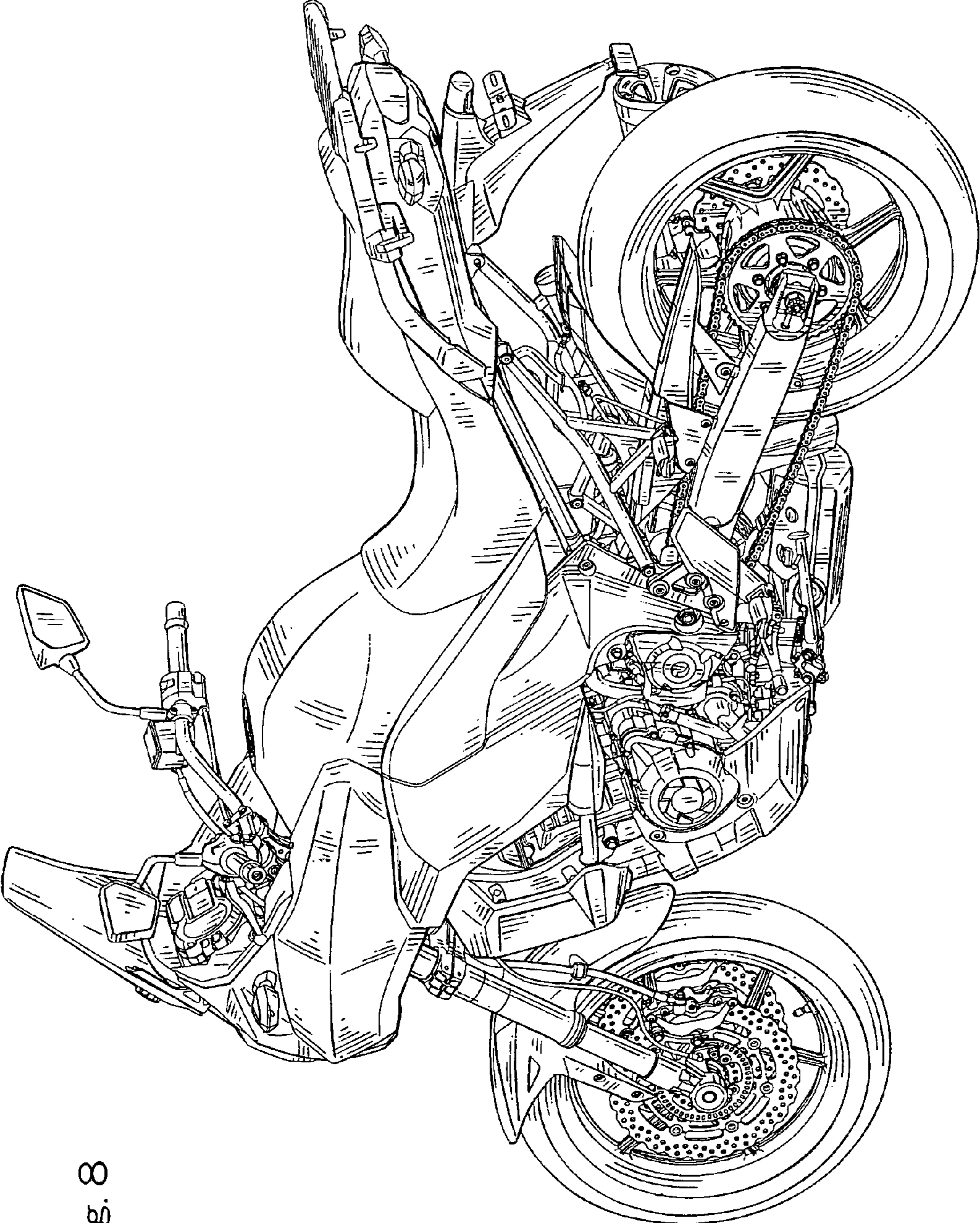

Fig. 8