



US00D669483S

(12) **United States Design Patent**
Ono

(10) **Patent No.:** **US D669,483 S**

(45) **Date of Patent:** **** Oct. 23, 2012**

(54) **DAMPER**

(75) Inventor: **Takashi Ono**, Sagamihara (JP)

(73) Assignee: **Nifco Inc.**, Yokohama-Shi (JP)

(**) Term: **14 Years**

(21) Appl. No.: **29/371,729**

(22) Filed: **Aug. 2, 2011**

(30) **Foreign Application Priority Data**

Feb. 7, 2011 (JP) 2011-002492

(51) **LOC (9) Cl.** **14-99**

(52) **U.S. Cl.** **D14/483**

(58) **Field of Classification Search** D14/474-483,
D14/496, 299; D8/323, 499, 343; 360/220,
360/221.1, 230, 237; 188/290, 252, 371,
188/378; 74/572, 574; D15/174, 199, 143
See application file for complete search history.

(56) **References Cited**

U.S. PATENT DOCUMENTS

5,211,267	A *	5/1993	Clark	188/276
5,277,282	A *	1/1994	Umemura	188/290
5,660,252	A *	8/1997	Lafon	188/130
5,839,548	A *	11/1998	Parker et al.	188/82.1
D486,833	S *	2/2004	Koizumi et al.	D14/483
D489,028	S *	4/2004	Nishiyama	D12/180

D513,264	S *	12/2005	Hayashi	D14/483
7,048,098	B1 *	5/2006	Moradian	188/306
7,065,829	B2 *	6/2006	Okabayashi et al.	16/51
D539,296	S *	3/2007	Hayashi et al.	D14/483
D540,809	S *	4/2007	Okabayashi et al.	D14/483
D566,123	S *	4/2008	Takei	D14/483
7,424,939	B2 *	9/2008	Hayashi et al.	188/290

* cited by examiner

Primary Examiner — Prabhakar Deshmukh

(74) *Attorney, Agent, or Firm* — Manabu Kanesaka

(57) **CLAIM**

The ornamental design for a damper, as shown and described.

DESCRIPTION

FIG. 1 is a perspective view of a damper showing my new design;
FIG. 2 is a front view thereof;
FIG. 3 is a rear view thereof;
FIG. 4 is a top plan view thereof;
FIG. 5 is a bottom plan view thereof;
FIG. 6 is a right side view thereof;
FIG. 7 is a left side view thereof; and,
FIG. 8 is a cross-sectional view thereof taken along the line
8-8 in FIG. 2.

The broken lines depict portions of the damper that form no part of claimed design.

1 Claim, 6 Drawing Sheets

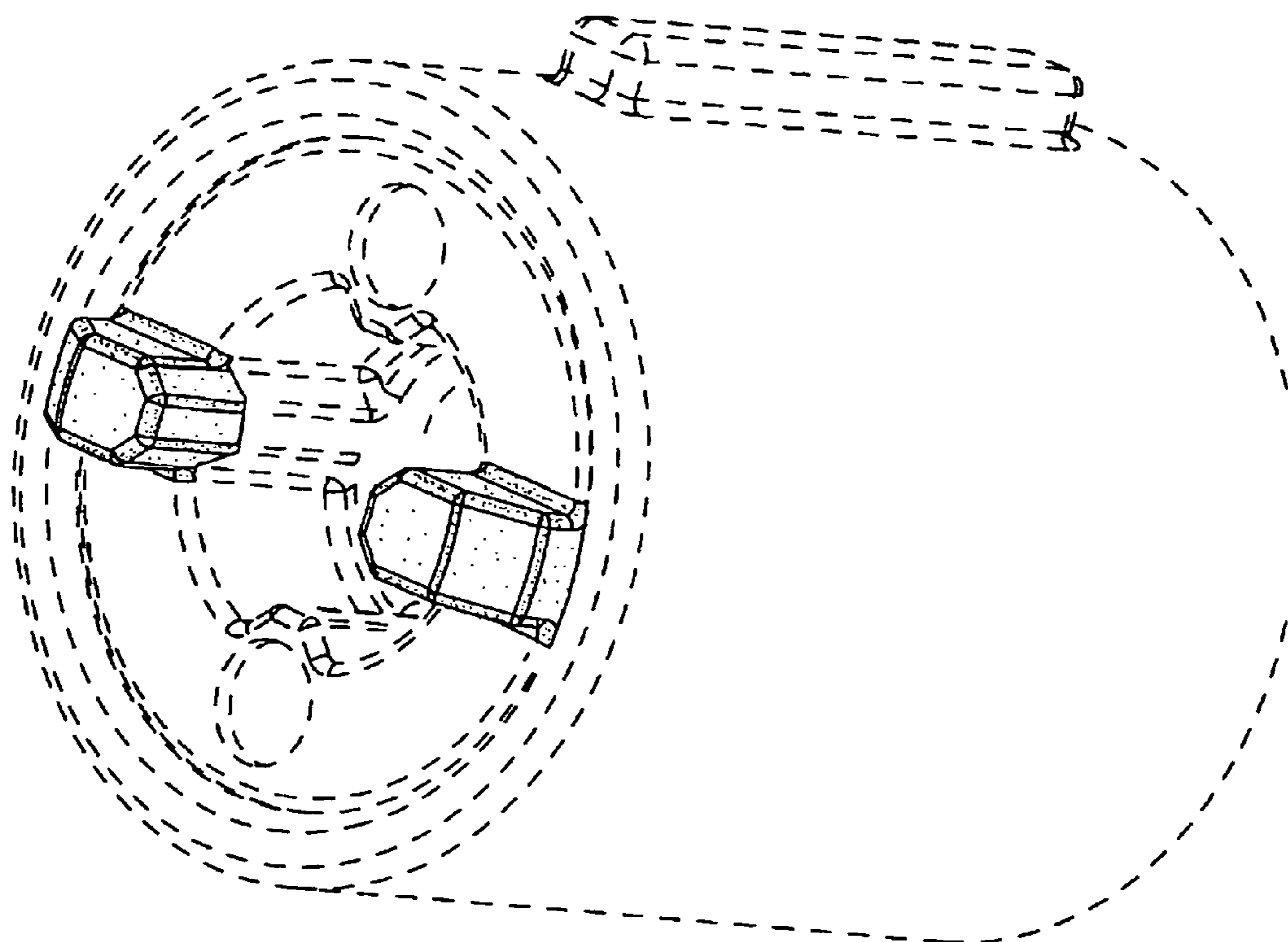

FIG. 1

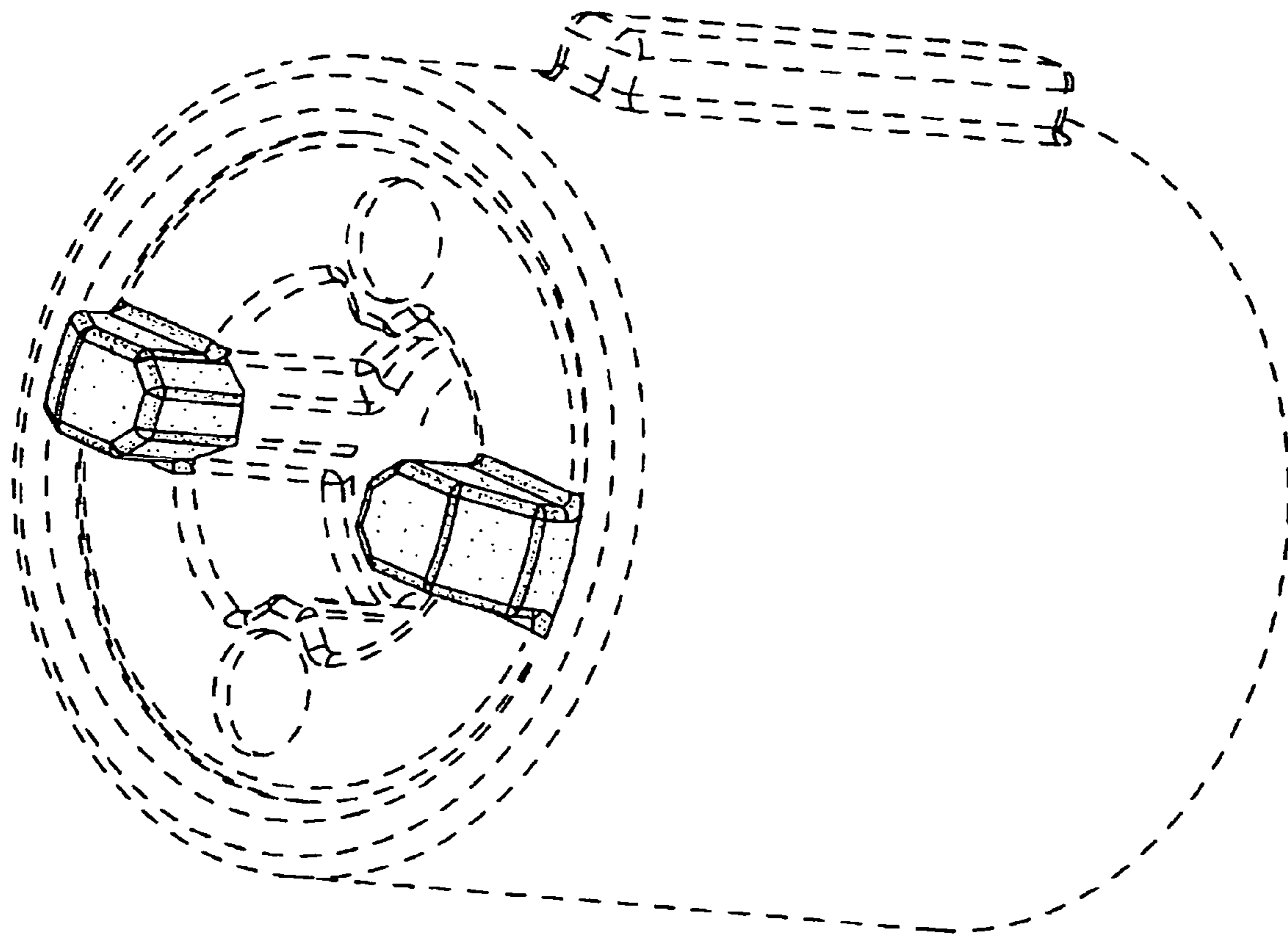

FIG. 2

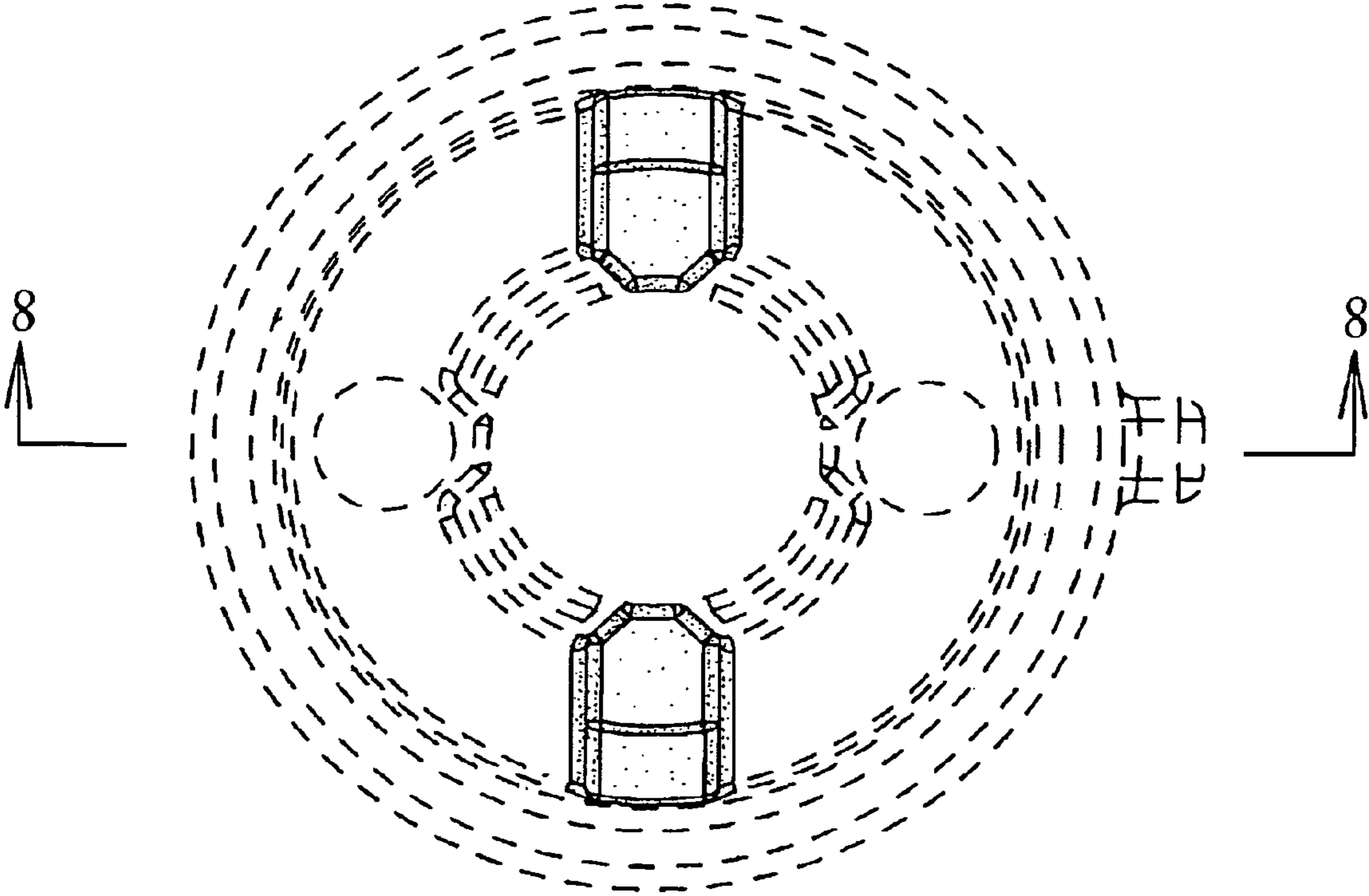

FIG. 3

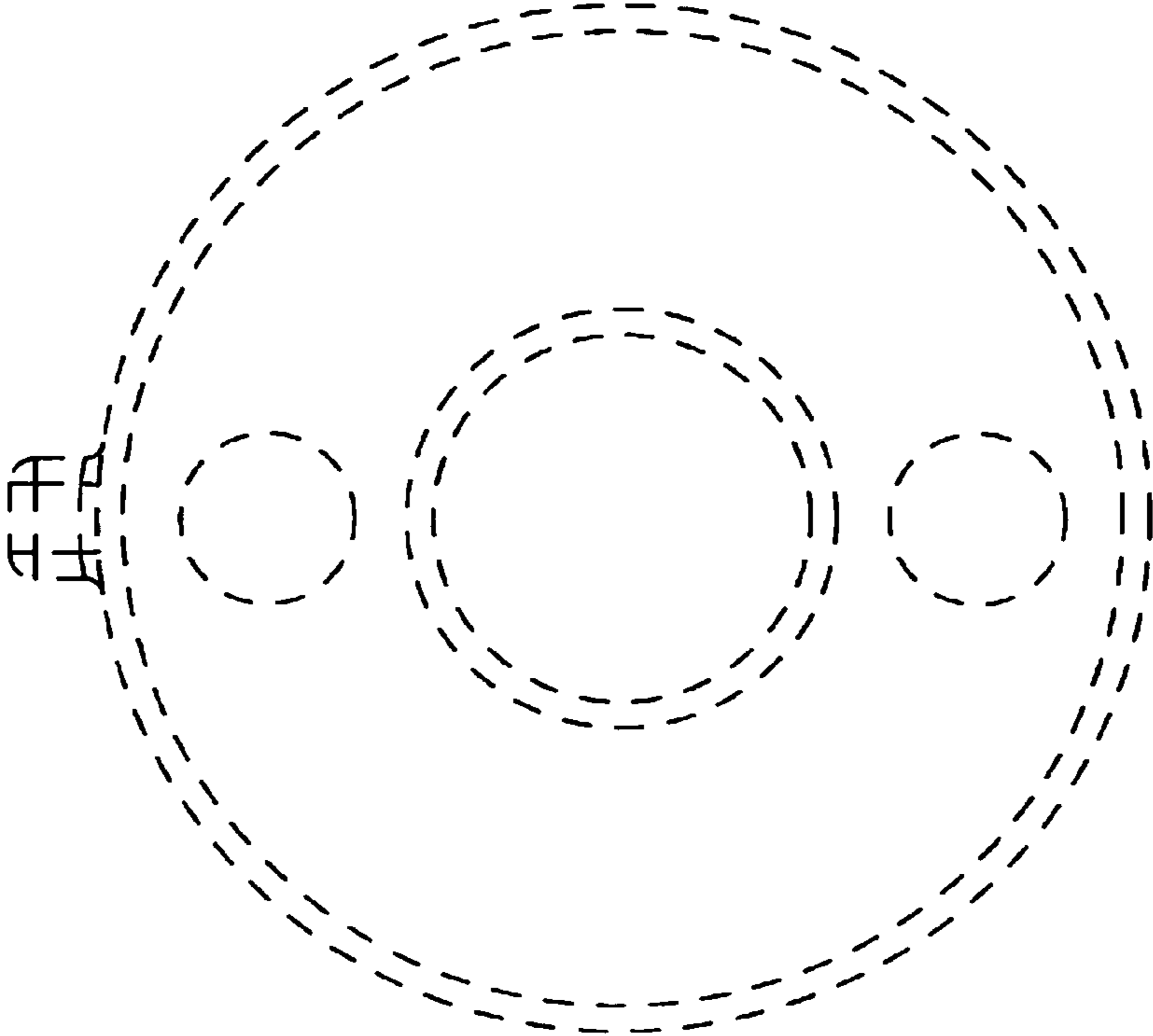

FIG. 4

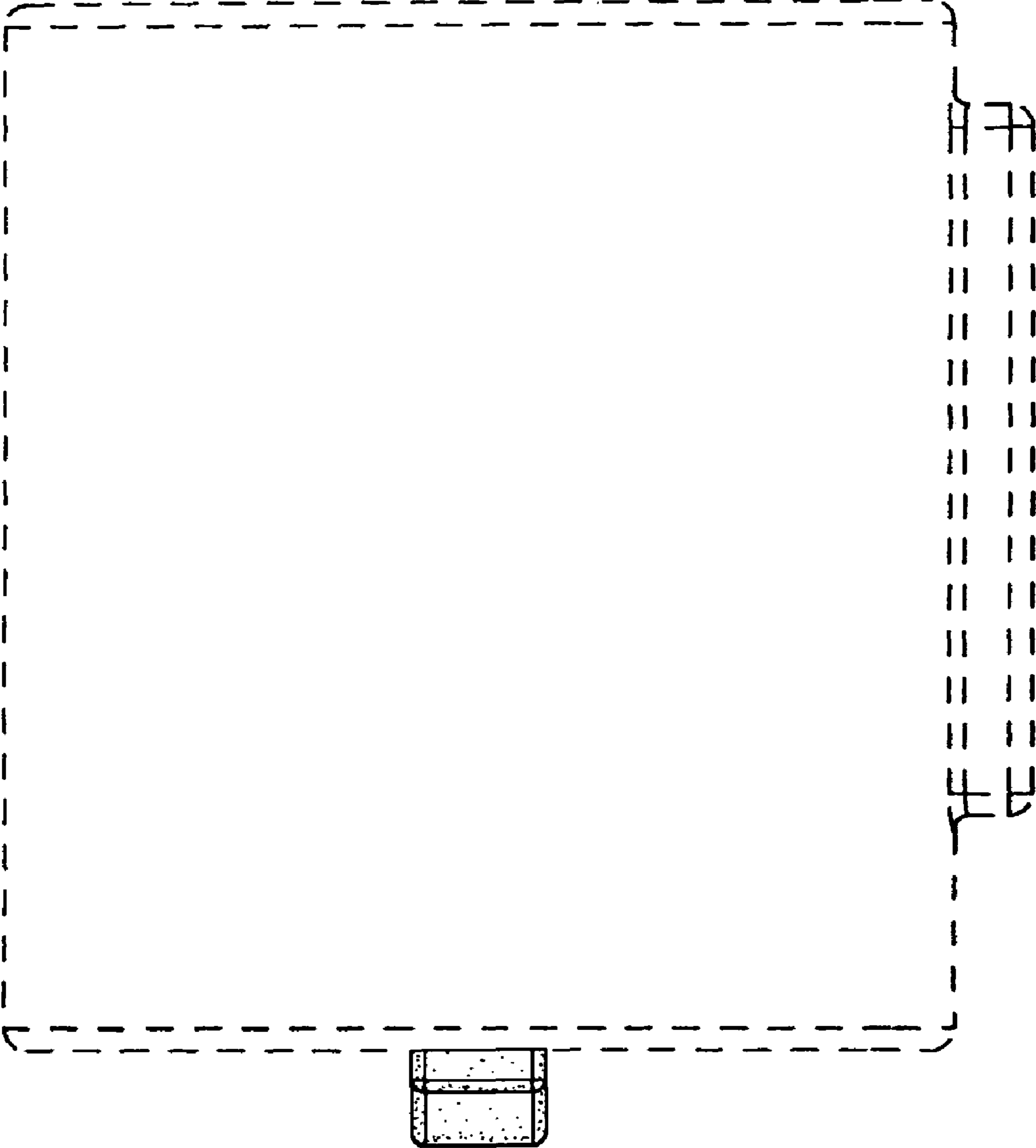

FIG. 5

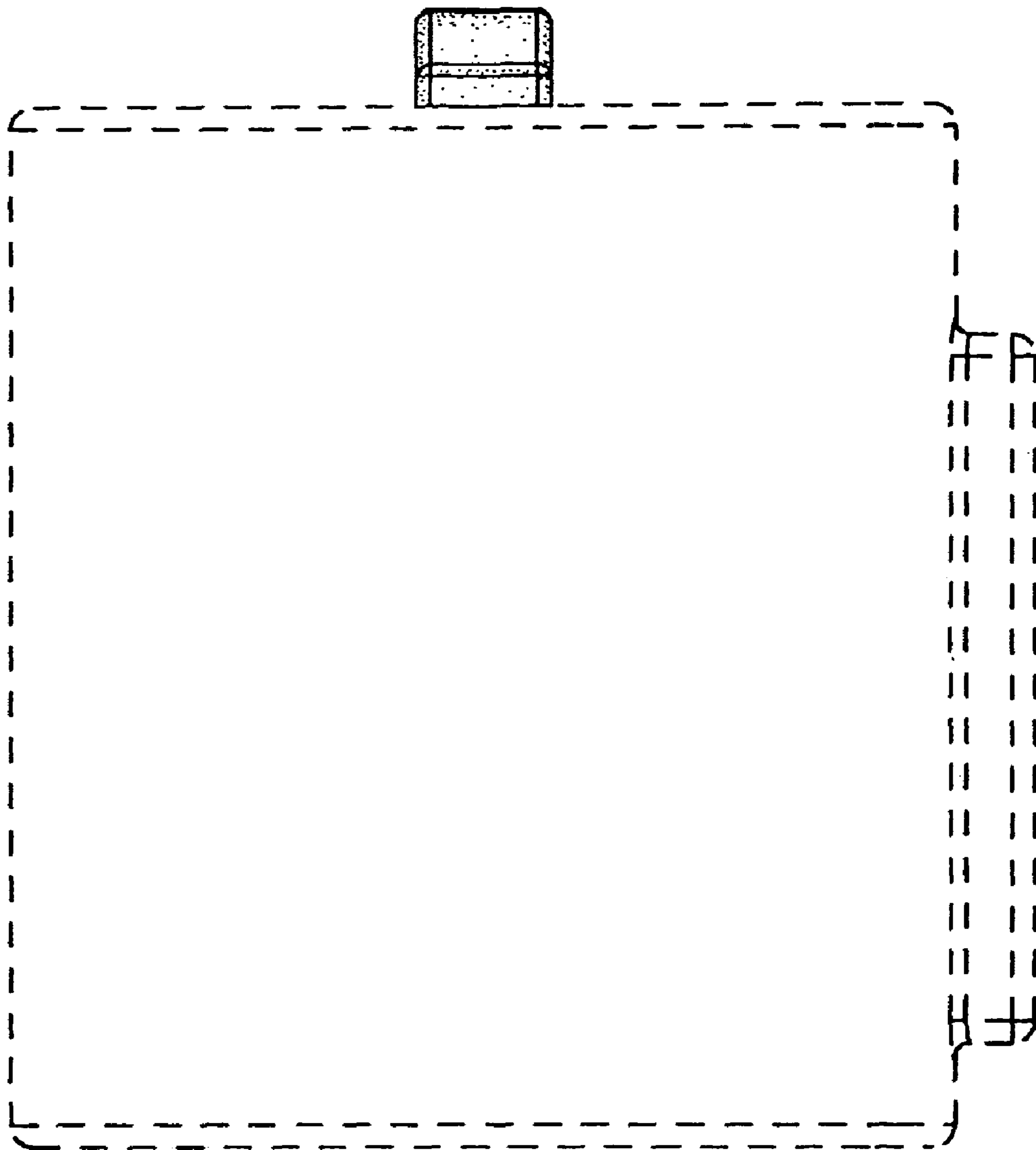

FIG. 6

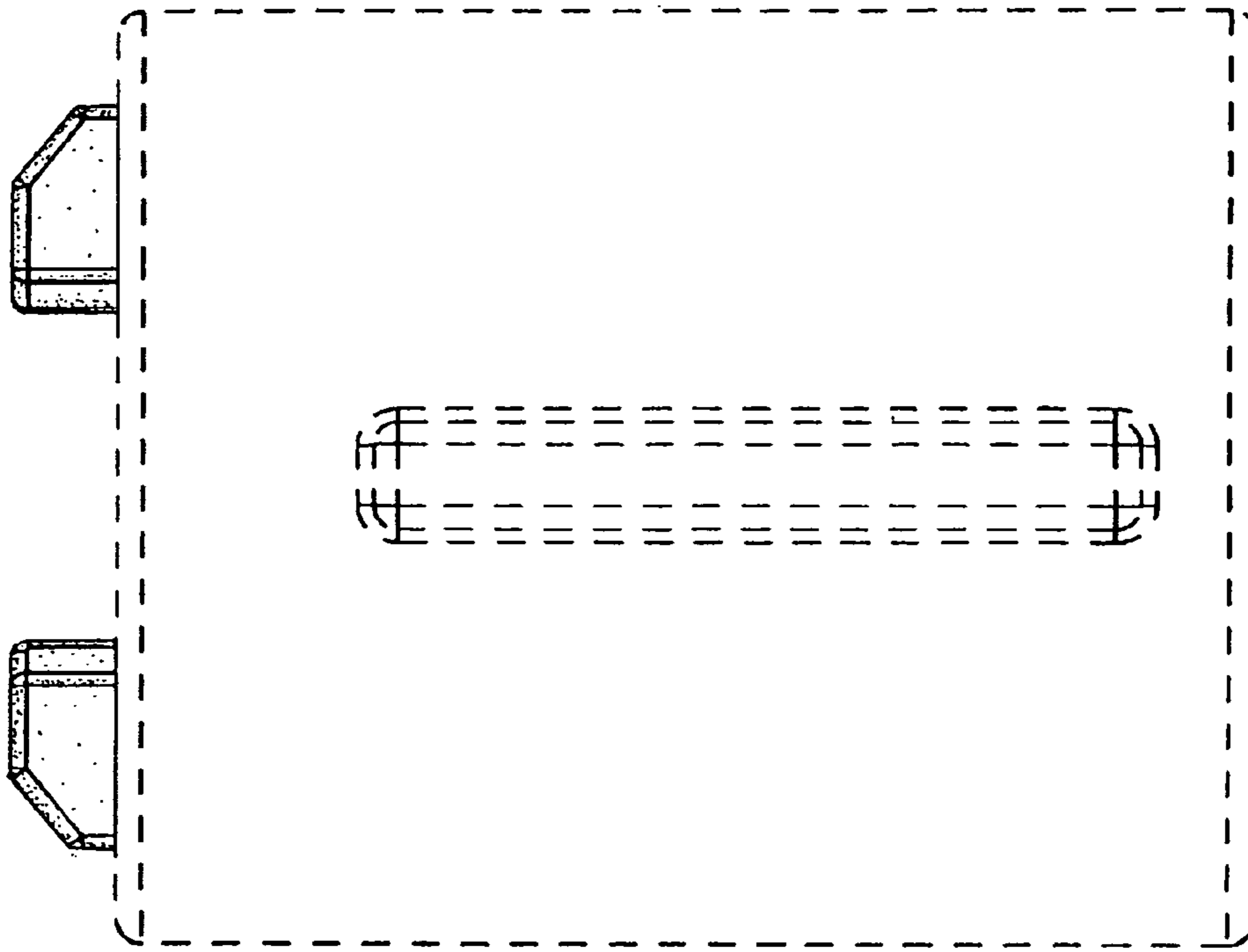

FIG. 7

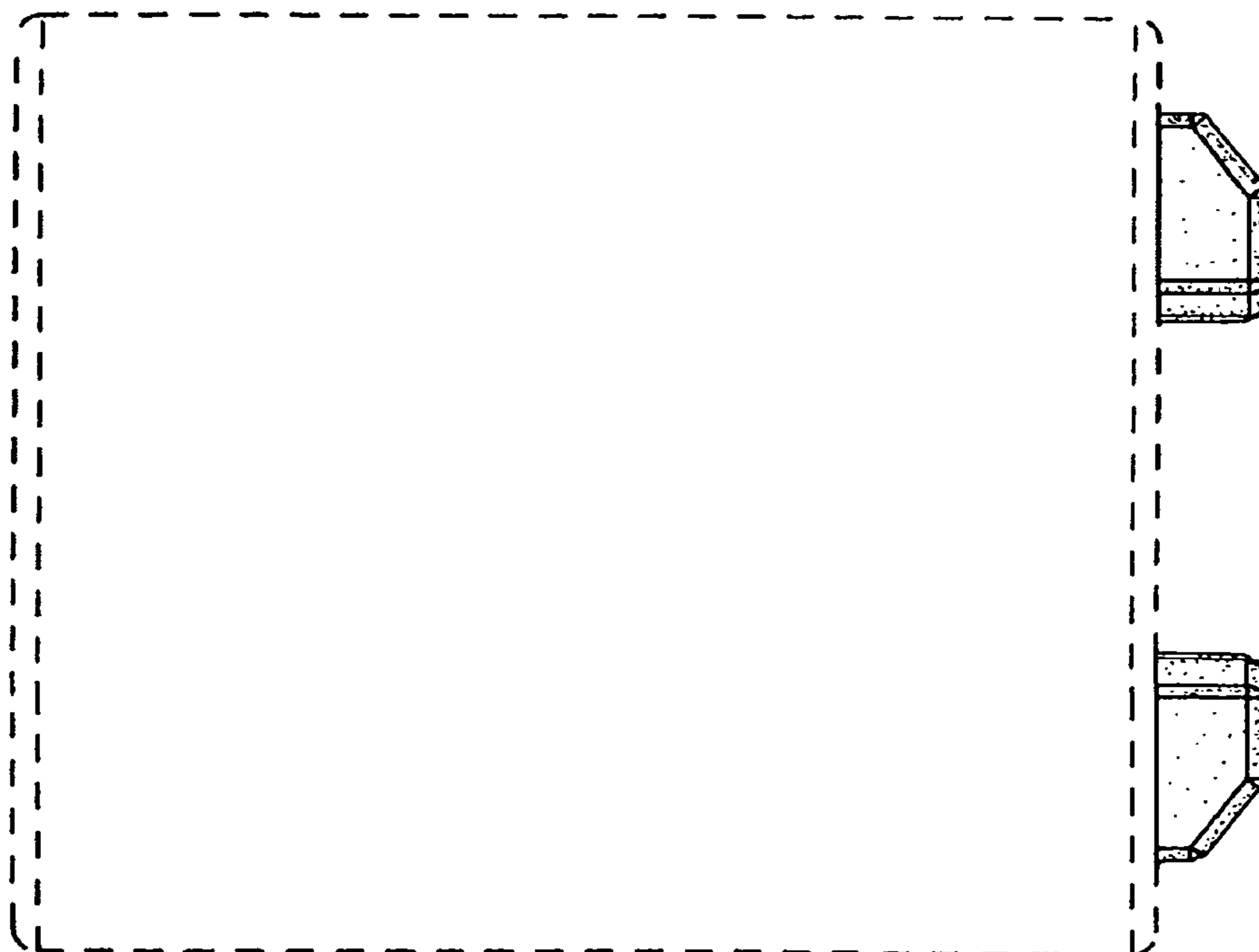

FIG. 8

