



US00D669379S

(12) **United States Design Patent**
McDonald et al.

(10) **Patent No.:** **US D669,379 S**
(45) **Date of Patent:** **** Oct. 23, 2012**

(54) **FLOW CELL FOR A FLOW METER**

(75) Inventors: **Benjamin Edward McDonald**,
Holliston, MA (US); **Mykhaylo Barsukov**,
Acton, MA (US)

(73) Assignee: **General Electric Company**,
Schenectady, NY (US)

(**) Term: **14 Years**

(21) Appl. No.: **29/404,665**

(22) Filed: **Oct. 24, 2011**

(51) **LOC (9) Cl.** **10-06**

(52) **U.S. Cl.** **D10/96**

(58) **Field of Classification Search** D10/96,
D10/97, 99, 100, 101; 116/264, 276; 73/273,
73/323, 861-861.41

See application file for complete search history.

(56) **References Cited**

U.S. PATENT DOCUMENTS

- 2010/0229654 A1 9/2010 Ao et al.
- 2012/0125121 A1* 5/2012 Gottlieb et al. 73/861.28
- 2012/0125122 A1* 5/2012 Gottlieb et al. 73/861.28

OTHER PUBLICATIONS

Altosonic V, Technical Datasheet, 5—Beam ultrasonic flowmeter for custody transfer of liquid hydrocarbons, Krohne, 20 pages.

Altosonic III, Technical Datasheet, Cost effective 3-beam ultrasonic flowmeter for custody transfer of liquid hydrocarbons, Krohne, Apr. 2006, 20 pages.

Cameron—LEFM 280Ci, Ultrasonic Flow Meter, Measurement Systems, Copyright 2010 Cameron International Corporation, 6 pages.

Cameron—LEFM 280CiRN, Ultrasonic Flow Meters, Measurement Systems, Cameron International Corporation, 6 pages.

* cited by examiner

Primary Examiner — Antoine D Davis

(74) *Attorney, Agent, or Firm* — Hiscock & Barclay LLP

(57) **CLAIM**

The ornamental design for a flow cell for a flow meter, as shown and described.

DESCRIPTION

FIG. 1 is a right side and top perspective view thereof; FIG. 2 is a left side and bottom perspective view thereof; FIG. 3 is a right side elevational view thereof; FIG. 4 is a left side elevational view thereof; FIG. 5 is a left end elevational view thereof; FIG. 6 is a right end elevational view thereof; FIG. 7 is a top view thereof; and, FIG. 8 is a bottom view of the flow cell for a flow meter of FIG. 1.

Broken lines are shown herein for illustrative purposes only, and form no part of the claimed design.

1 Claim, 5 Drawing Sheets

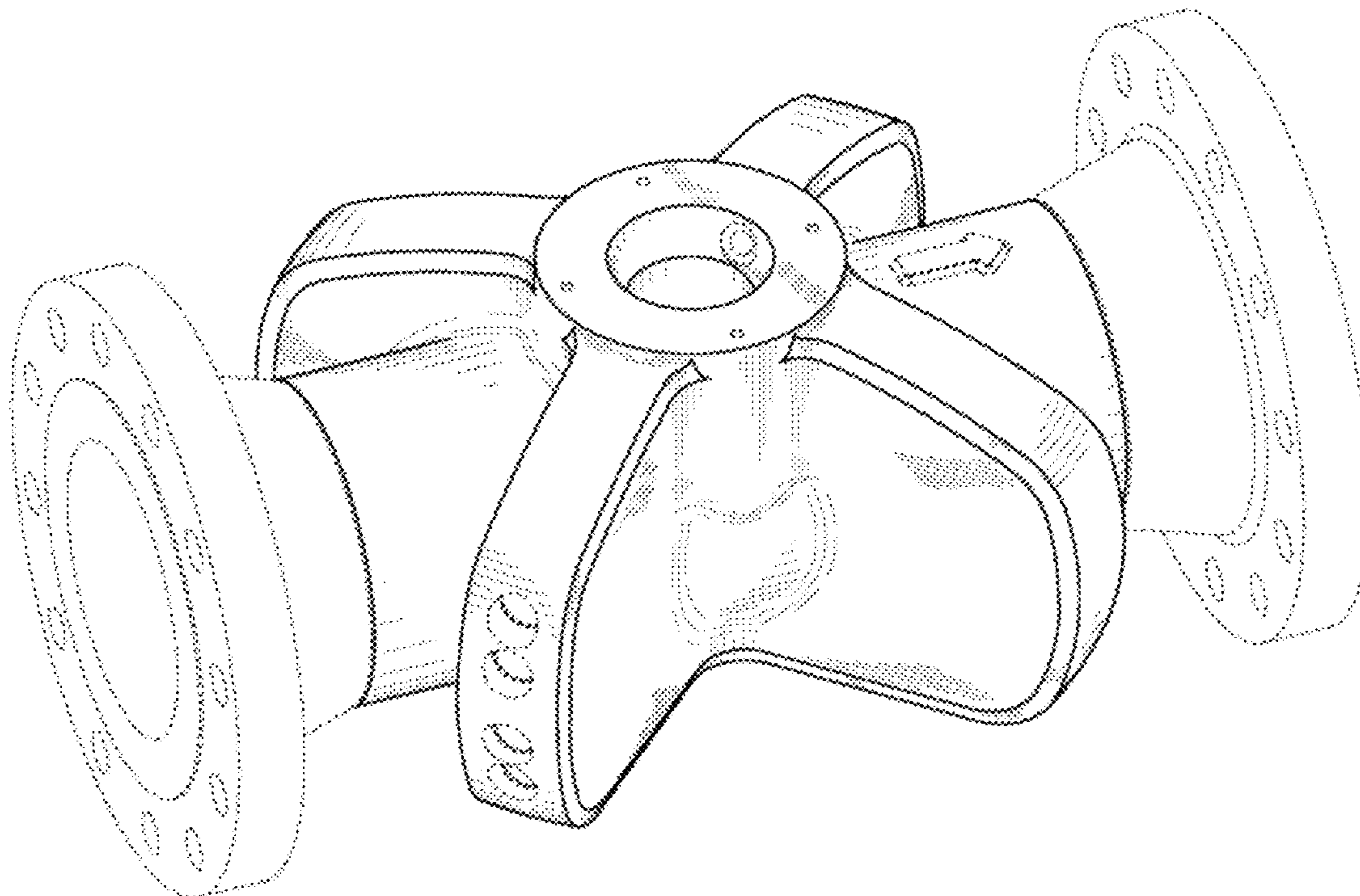

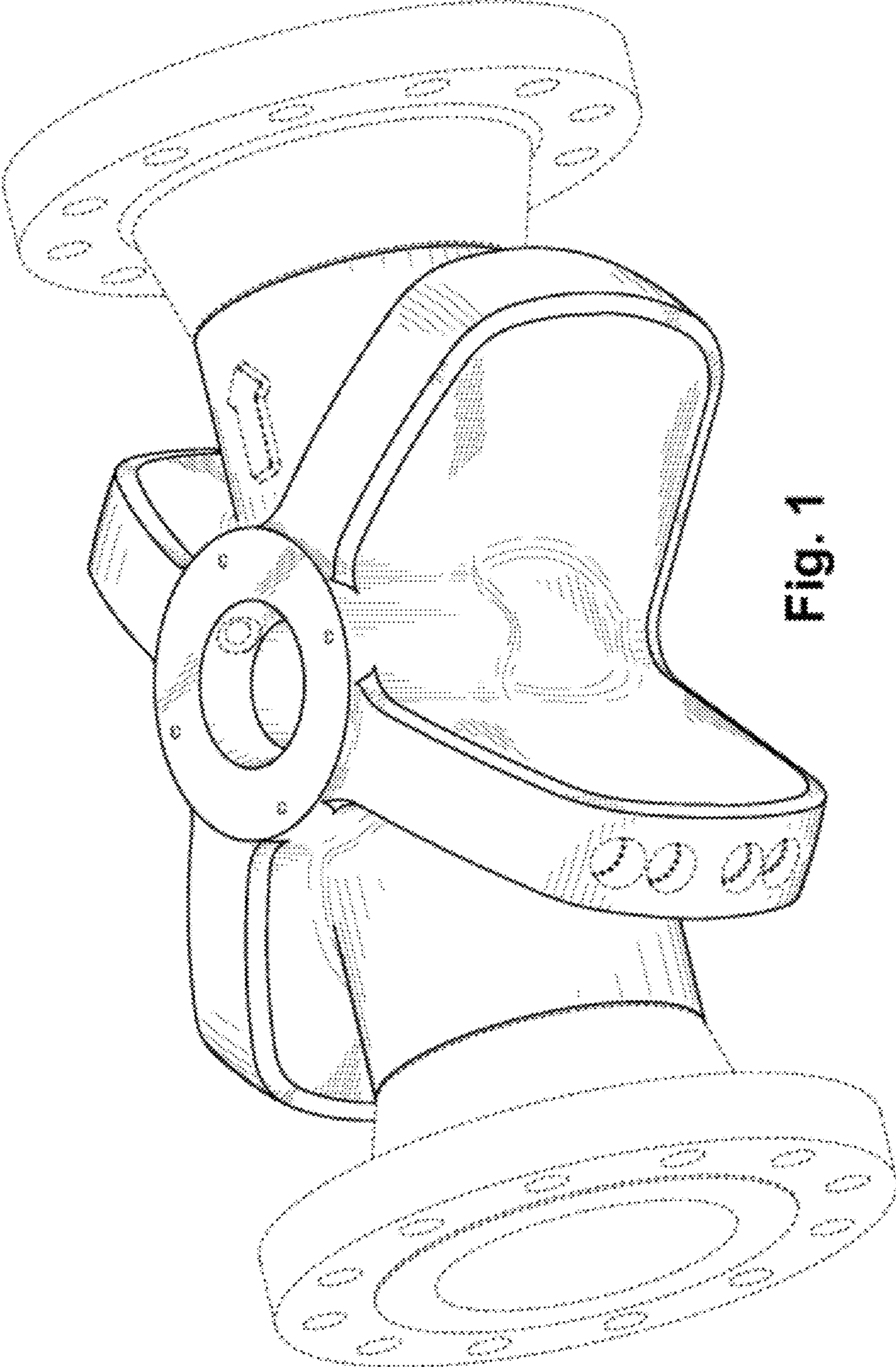

Fig. 1

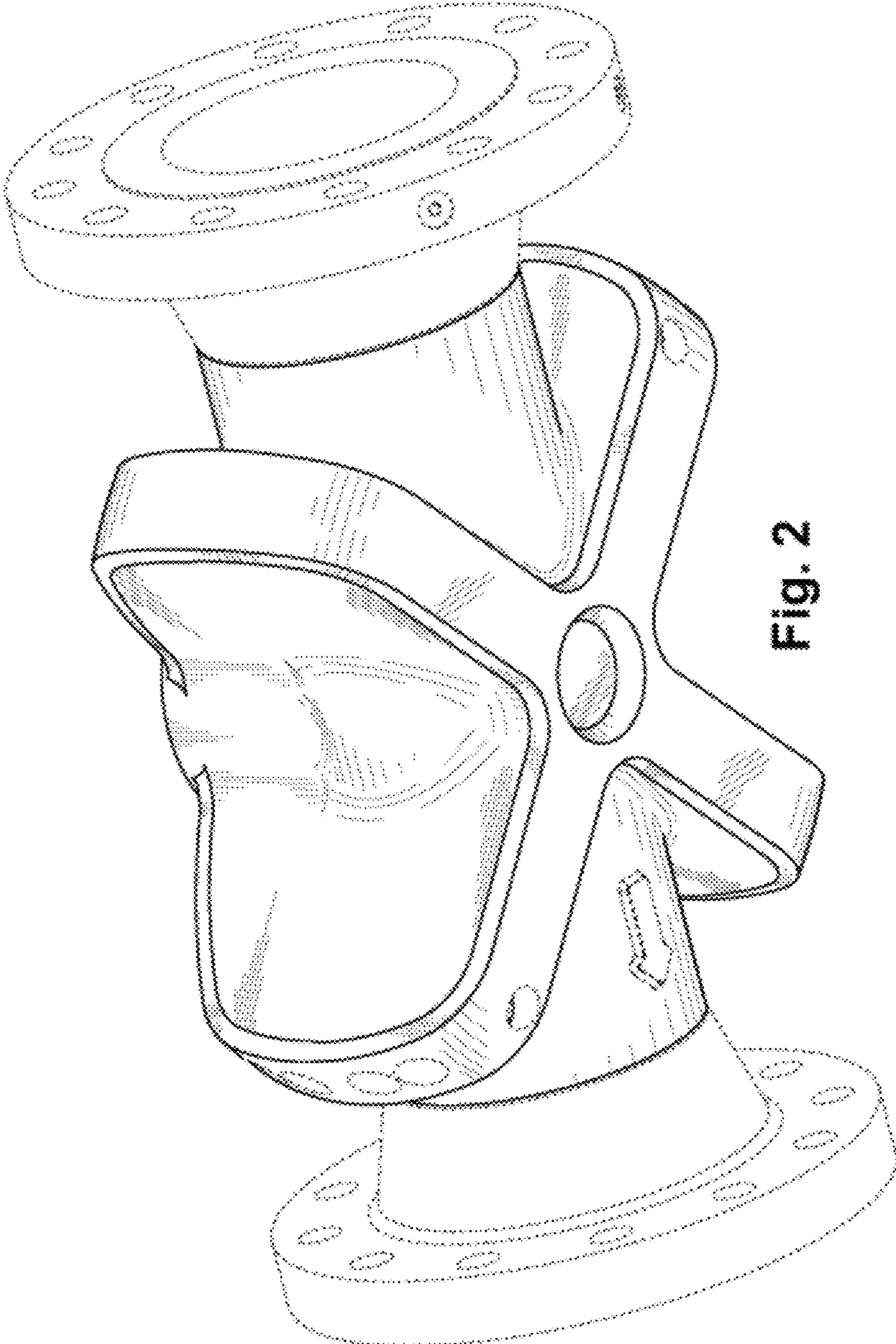

Fig. 2

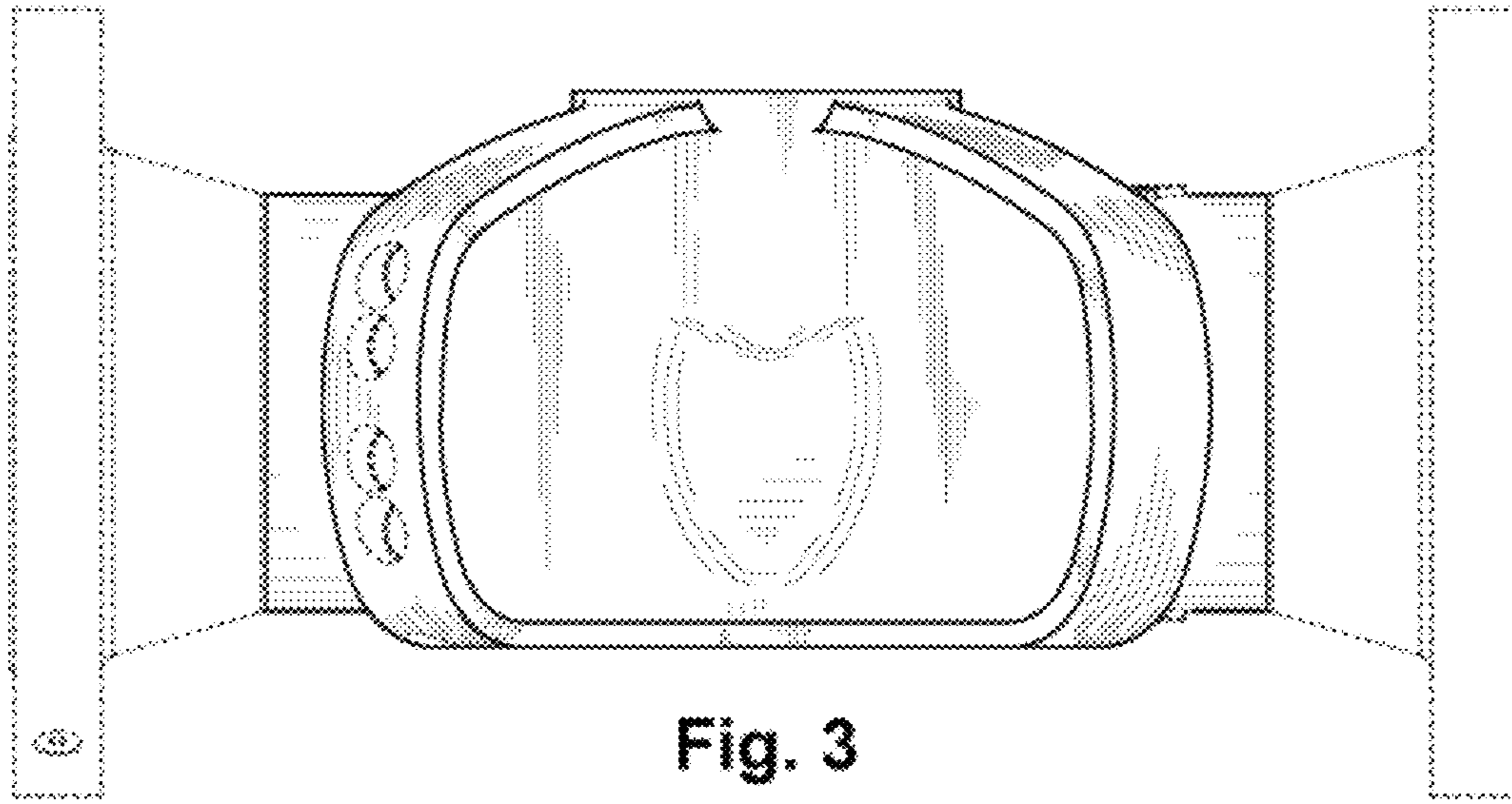

Fig. 3

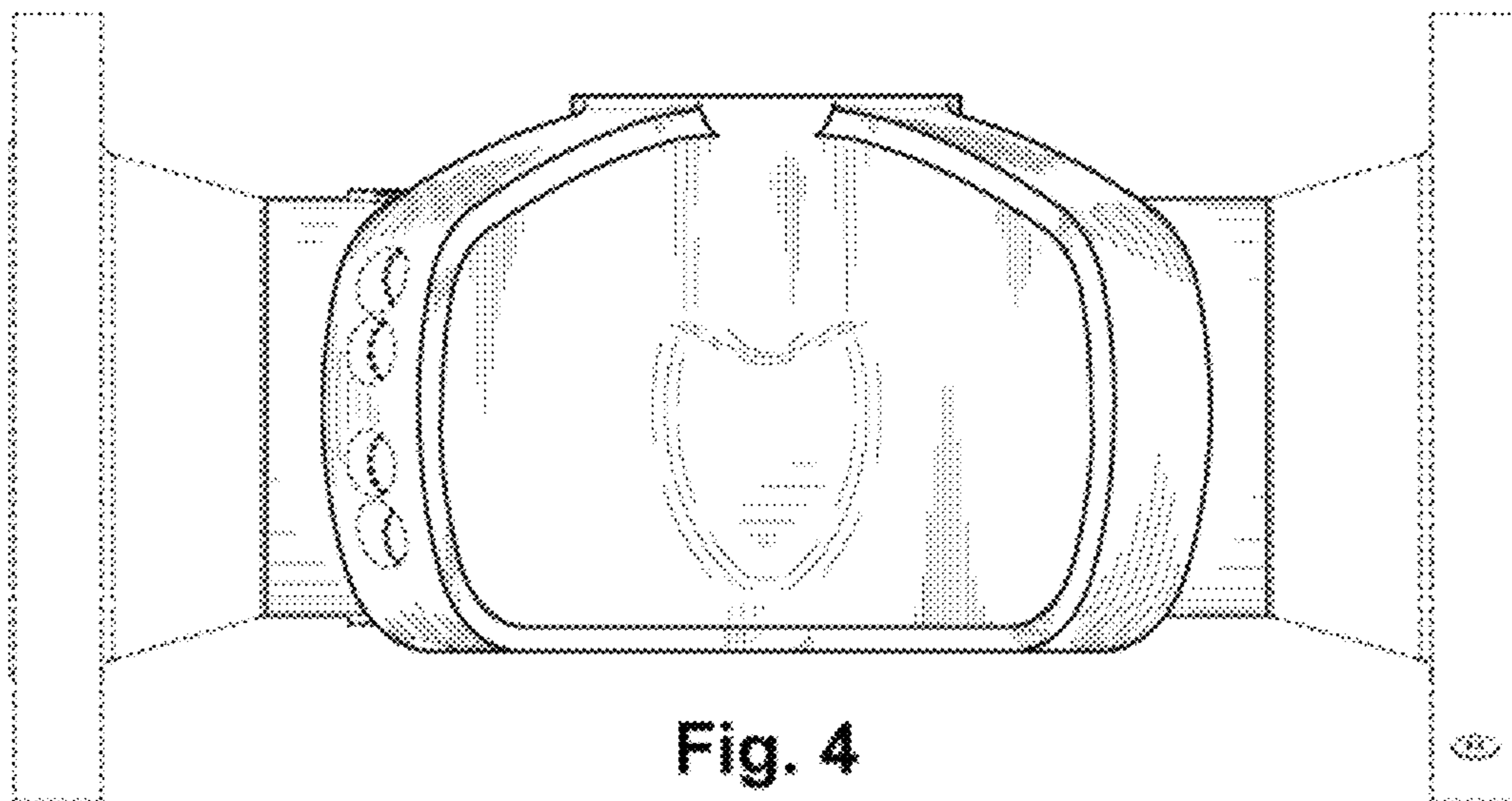

Fig. 4

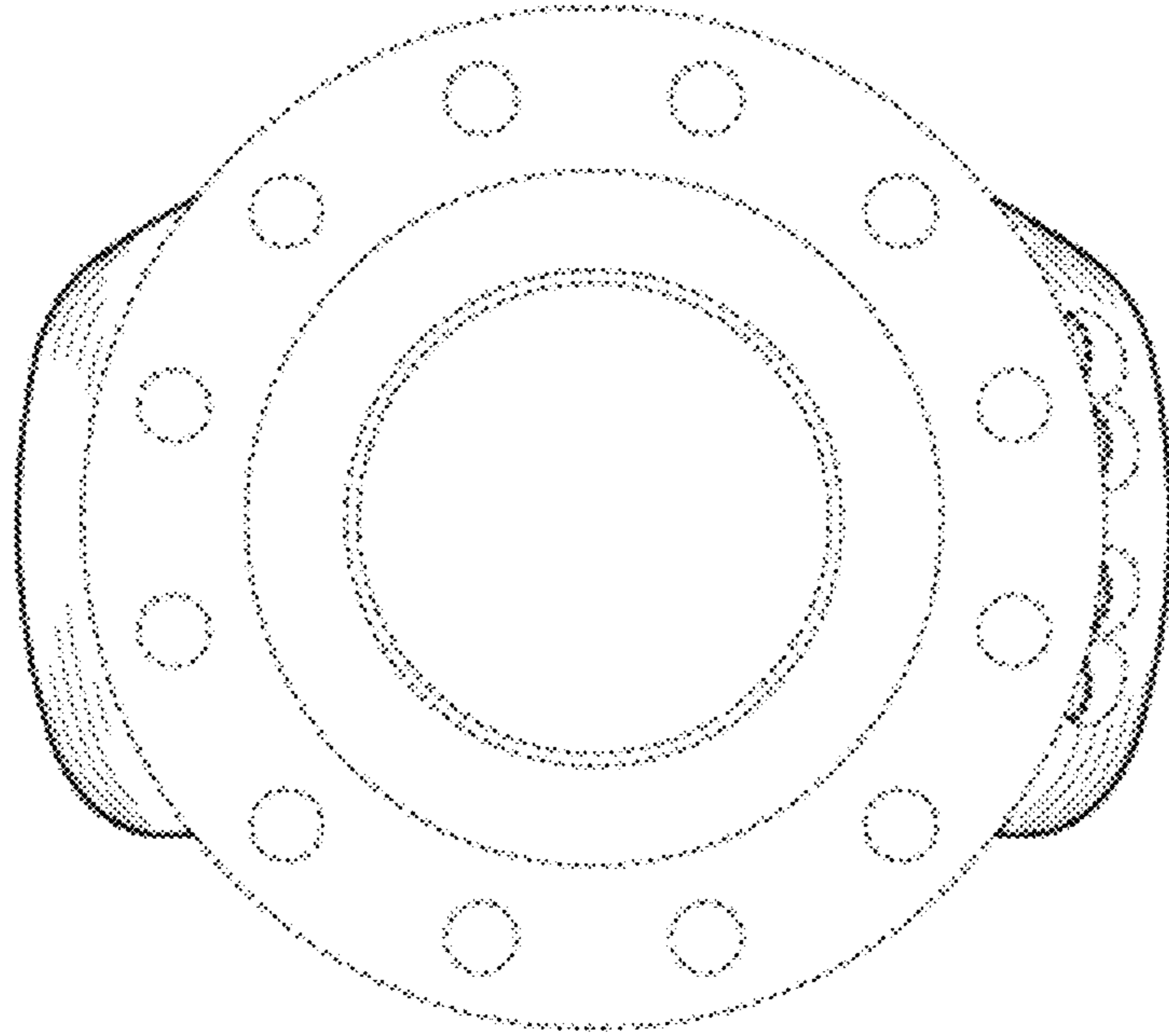

Fig. 5

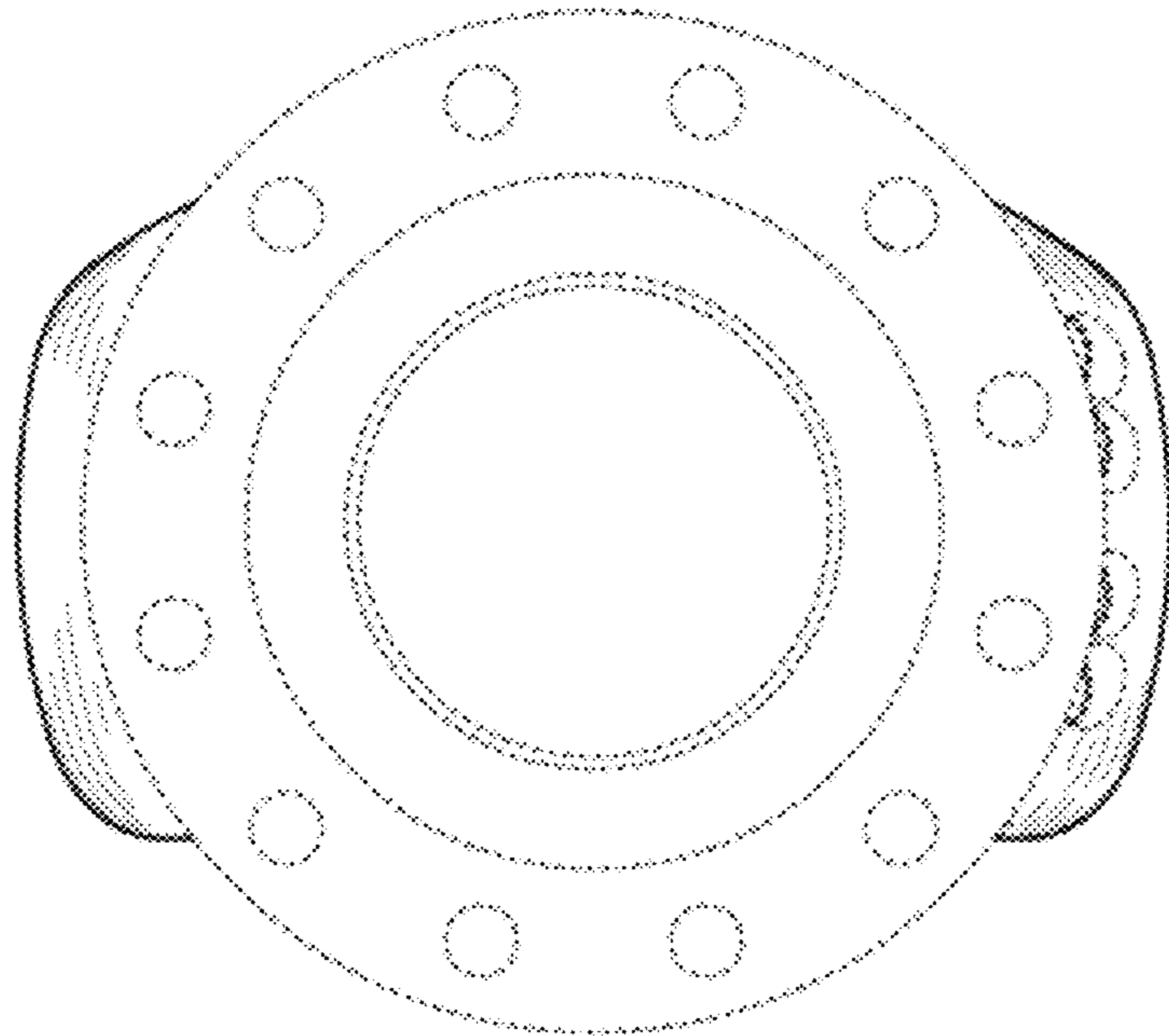

Fig. 6

