

US00D669002S

(12) **United States Design Patent**
Davidson et al.

(10) **Patent No.:** **US D669,002 S**
(45) **Date of Patent:** **** Oct. 16, 2012**

(54) **FRONT END PORTION OF A VEHICLE**

(75) Inventors: **Benjamin Davidson**, Torrance, CA
(US); **Guillermo Gonzalez**, Lawndale,
CA (US)

(73) Assignee: **Honda Motor Co., Ltd.**, Tokyo (JP)

(**) Term: **14 Years**

(21) Appl. No.: **29/399,517**

(22) Filed: **Aug. 15, 2011**

(51) **LOC (9) Cl.** **12-16**

(52) **U.S. Cl.** **D12/164**

(58) **Field of Classification Search** D12/164,
D12/196, 90-92, 86, 163; D21/424, 433,
D21/434; 296/181.1, 181.5

See application file for complete search history.

(56) **References Cited**

U.S. PATENT DOCUMENTS

D633,009 S * 2/2011 Matei et al. D12/91
D633,823 S * 3/2011 Matei et al. D12/91
D637,531 S * 5/2011 Miyazawa D12/163
D638,752 S * 5/2011 Date et al. D12/91

D642,964 S * 8/2011 Miyazawa D12/163
D645,383 S * 9/2011 Mochizuki D12/164
D646,606 S * 10/2011 Kato et al. D12/91
D648,247 S * 11/2011 Nemoto D12/91
D660,751 S * 5/2012 Matei et al. D12/163

* cited by examiner

Primary Examiner — Melody N Brown

(74) *Attorney, Agent, or Firm* — Plumsea Law Group, LLC;
Mark E. Duell

(57) **CLAIM**

The ornamental design for a front end portion of a vehicle, as shown and described.

DESCRIPTION

FIG. 1 is a perspective view of a front end portion of a vehicle showing our new design;
FIG. 2 is a front elevational view thereof;
FIG. 3 is a side elevational view thereof, the opposite side elevational view being a mirror image; and,
FIG. 4 is a top plan view thereof.
The broken line showings of the lozenge shapes in the center of the grille form no part of the claimed design.

1 Claim, 2 Drawing Sheets

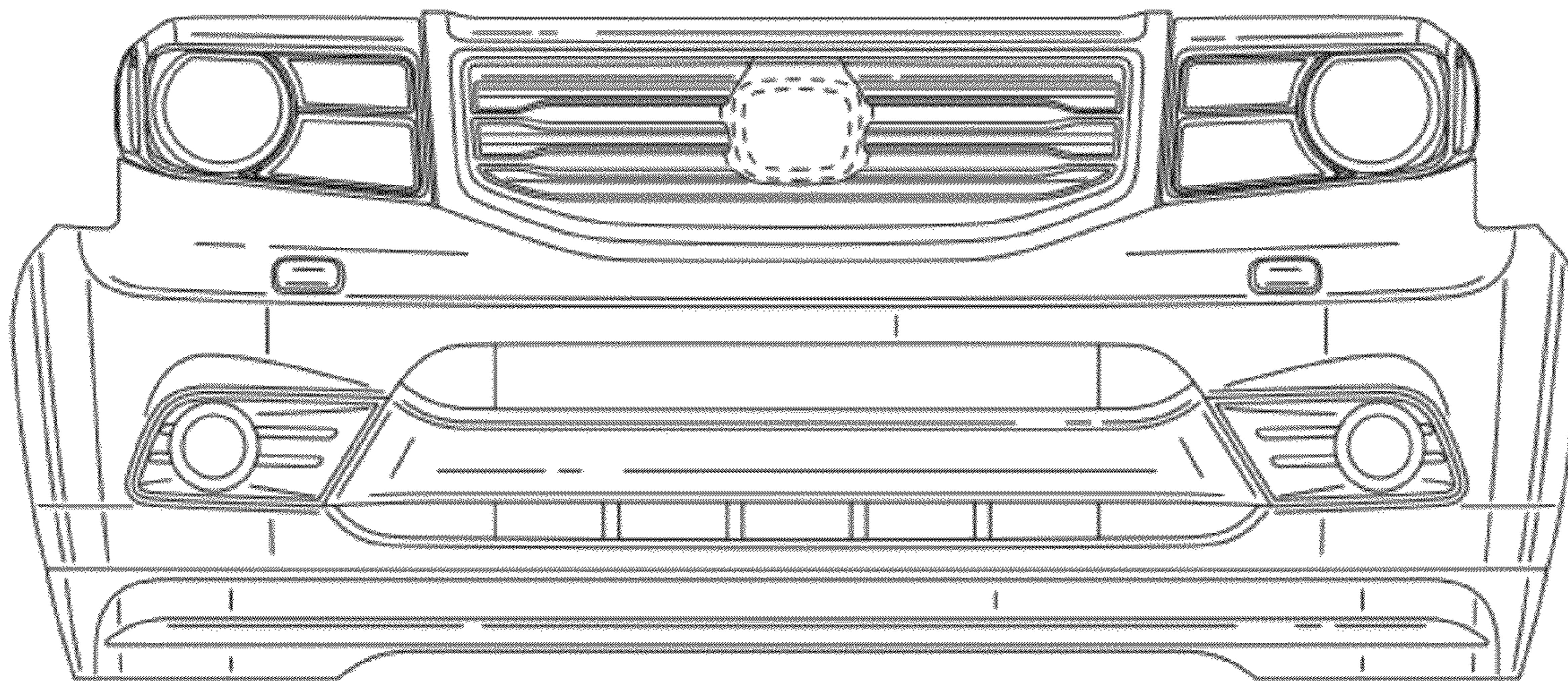

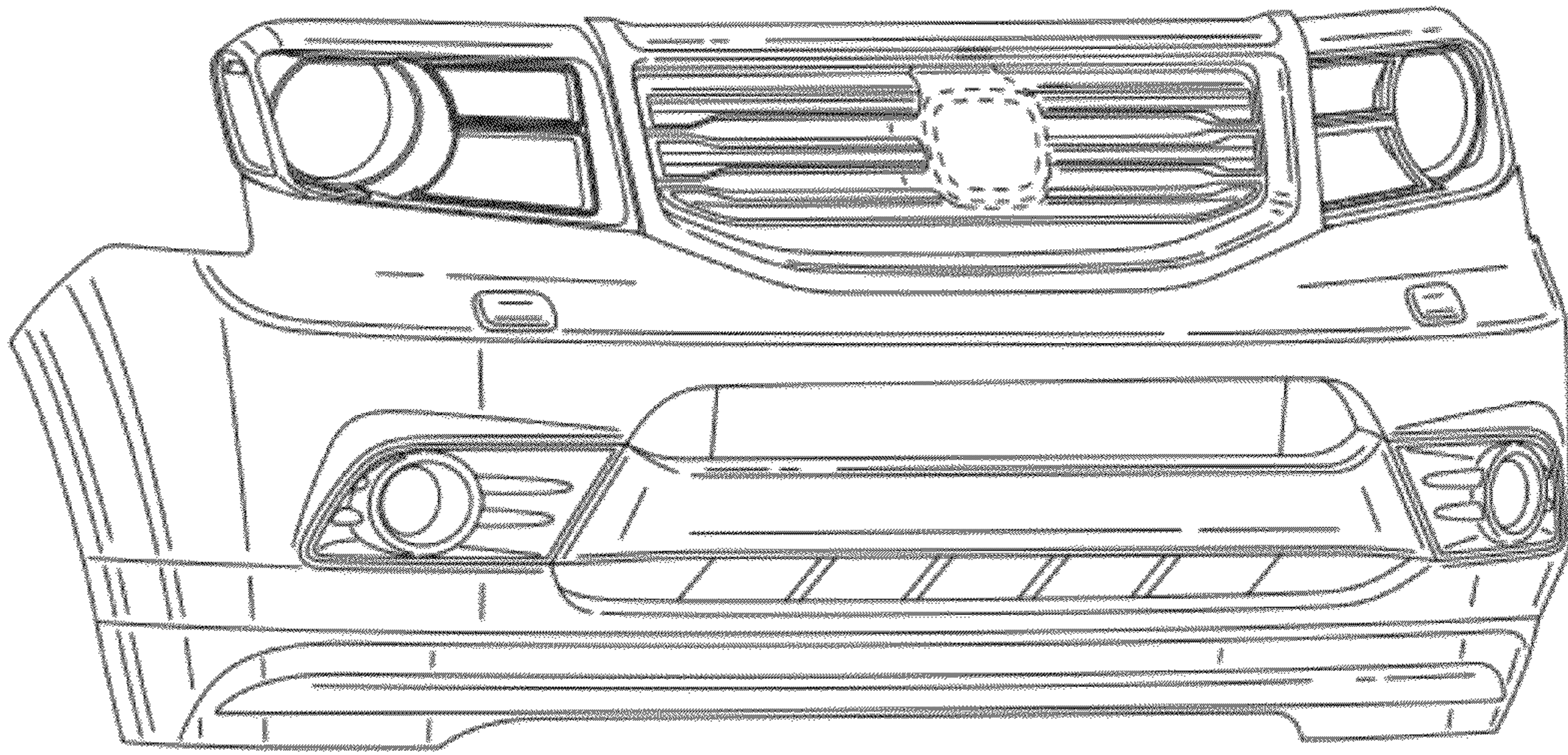

FIG. 1

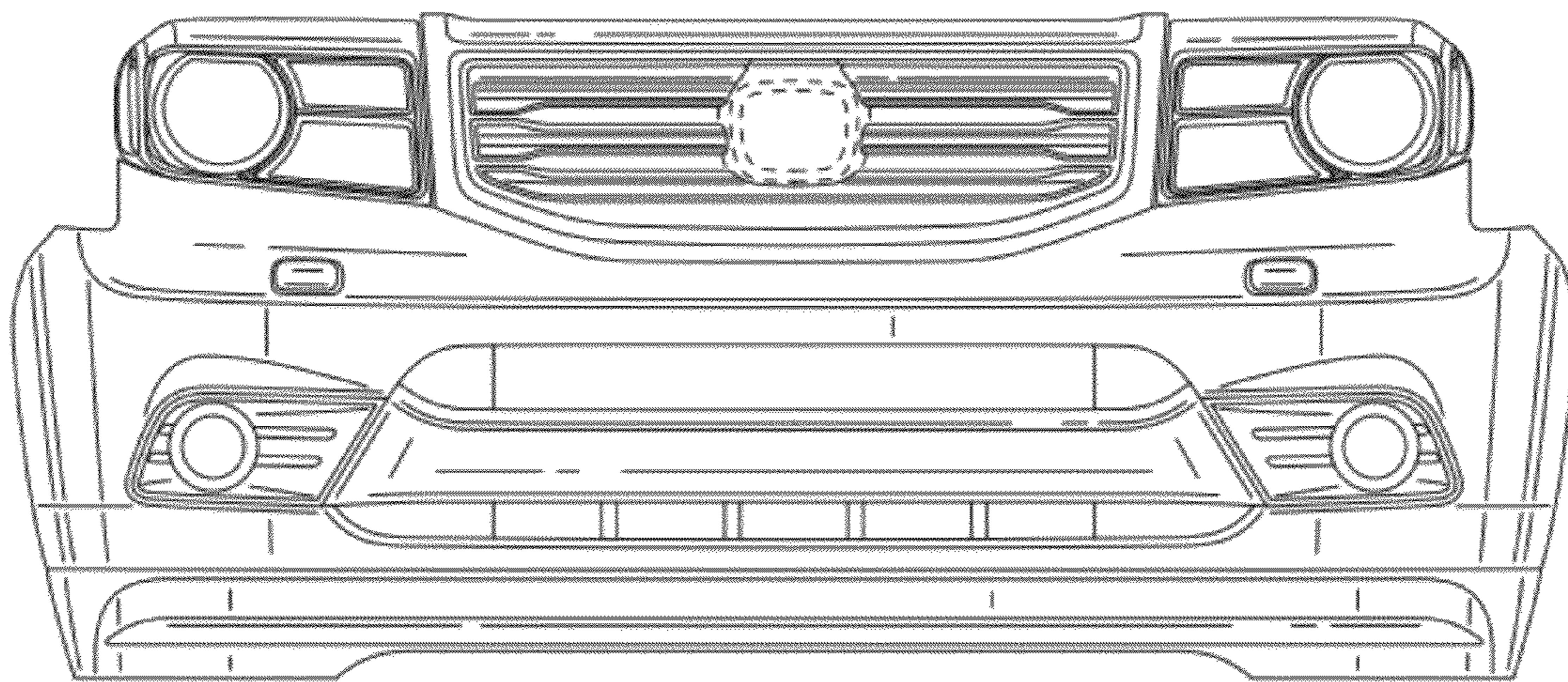

FIG. 2

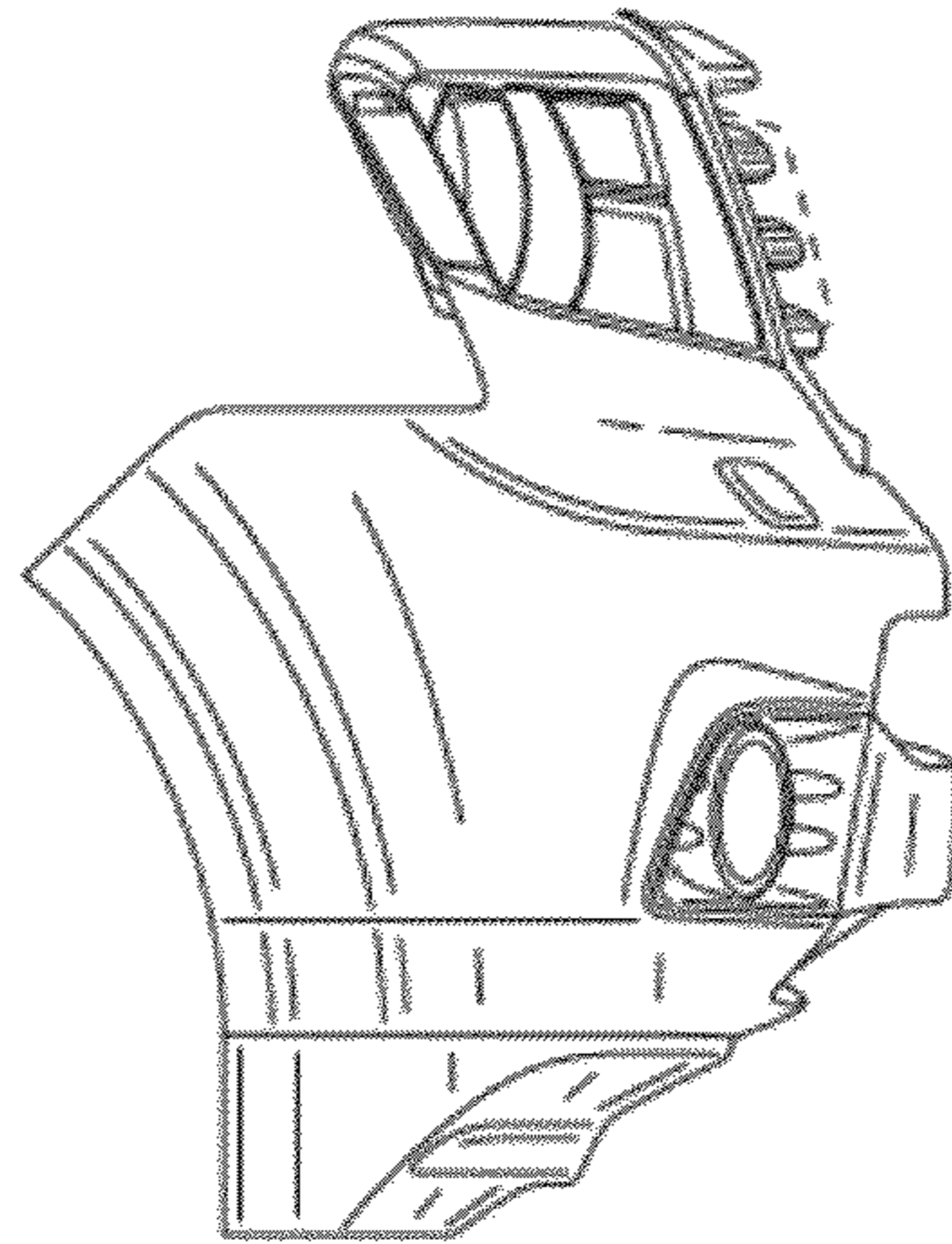

FIG. 3

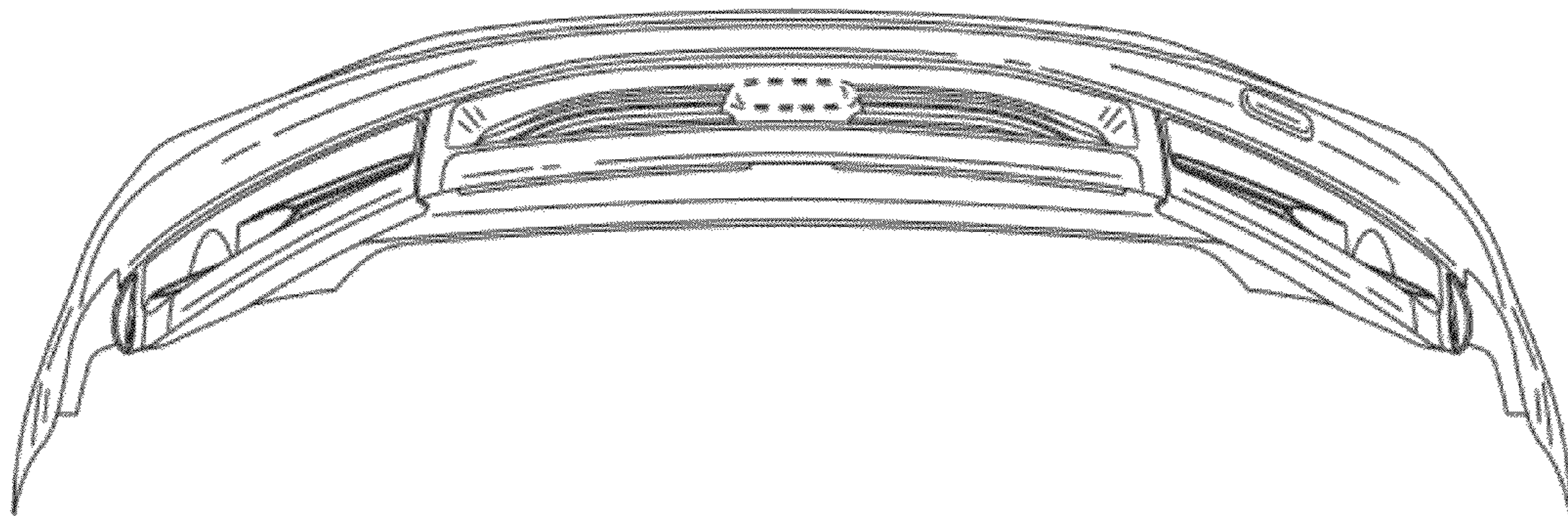

FIG. 4