

US00D668869S

(12) **United States Design Patent**
Yamamoto et al.

(10) **Patent No.:** **US D668,869 S**
(45) **Date of Patent:** **** Oct. 16, 2012**

(54) **TOOL BOX**

(75) Inventors: **Yuji Yamamoto**, Anjo (JP); **Kiyozumi Kokawa**, Anjo (JP)

(73) Assignee: **Makita Corporation**, Anjo-shi (JP)

(**) Term: **14 Years**

(21) Appl. No.: **29/417,899**

(22) Filed: **Apr. 10, 2012**

(30) **Foreign Application Priority Data**

Feb. 15, 2012	(JP)	2012-003139
Feb. 15, 2012	(JP)	2012-003140
Feb. 15, 2012	(JP)	2012-003141
Feb. 15, 2012	(JP)	2012-003142

(51) **LOC (9) Cl.** **03-01**

(52) **U.S. Cl.** **D3/281; D3/905**

(58) **Field of Classification Search** D3/254,
D3/260, 273, 276, 280, 283-291, 301, 302,
D3/303, 905; 220/523, 524, 527; 206/349,
206/372-379; 190/109, 111, 115, 107, 126,
190/903; D7/605

See application file for complete search history.

(56) **References Cited**

U.S. PATENT DOCUMENTS

D234,273	S	*	2/1975	Wilson	D3/272
D313,502	S	*	1/1991	Vasky	D3/284
D413,203	S	*	8/1999	Zurwelle et al.	D3/276
D417,956	S	*	12/1999	Story et al.	D3/295
D431,108	S	*	9/2000	Lewis et al.	D3/276
D471,710	S	*	3/2003	Rushworth	D3/276
D493,616	S	*	8/2004	Hardy	D3/281
D523,242	S	*	6/2006	Hardigg et al.	D3/276
D527,181	S	*	8/2006	Henning et al.	D3/276
D627,967	S	*	11/2010	Kuhls	D3/273
D627,968	S	*	11/2010	Brunner	D3/281
D640,056	S	*	6/2011	Twig et al.	D3/281

FOREIGN PATENT DOCUMENTS

EP	0555533	B1	8/1994
EP	0916302	A3	6/1999

OTHER PUBLICATIONS

German Industrial Design Document No. M9200410.5; Published May 25, 1992; German Patent and Brand Office.

Makita Plunge Cut Circular Saw SP 6000 brochure; Makita Corporation, Printed in Japan; Mar. 2007.

Japanese Office Action mailed Oct. 6, 2011 for Japanese Design Application No. 2011-1338.

Japanese Office Action mailed Oct. 6, 2011 for Japanese Design Application No. 2011-1339.

* cited by examiner

Primary Examiner — Jennifer Rivard

(74) *Attorney, Agent, or Firm* — Global IP Counselors, LLP

(57) **CLAIM**

The ornamental design for a tool box, as shown and described.

DESCRIPTION

FIG. 1 is a top, front and right side perspective view of a tool box in accordance with a first embodiment of our new design; FIG. 2 is a bottom, rear and right side perspective view of the tool box in accordance with the first embodiment of our new design;

FIG. 3 is a front elevational view of the tool box in accordance with my the first embodiment of new design;

FIG. 4 is a rear elevational view of the tool box in accordance with the first embodiment of our new design;

FIG. 5 is a top plan view of the tool box in accordance with the first embodiment of our new design;

FIG. 6 is a bottom plan view of the tool box in accordance with the first embodiment of our new design;

FIG. 7 is a right side elevational view of the tool box in accordance with the first embodiment of our new design;

FIG. 8 is a left side elevational view of the tool box in accordance with the first embodiment of our new design;

FIG. 9 is a top, front and right side perspective view of a tool box in accordance with a second embodiment of our new design;

FIG. 10 is a bottom, rear and right side perspective view of the tool box in accordance with the second embodiment of our new design;

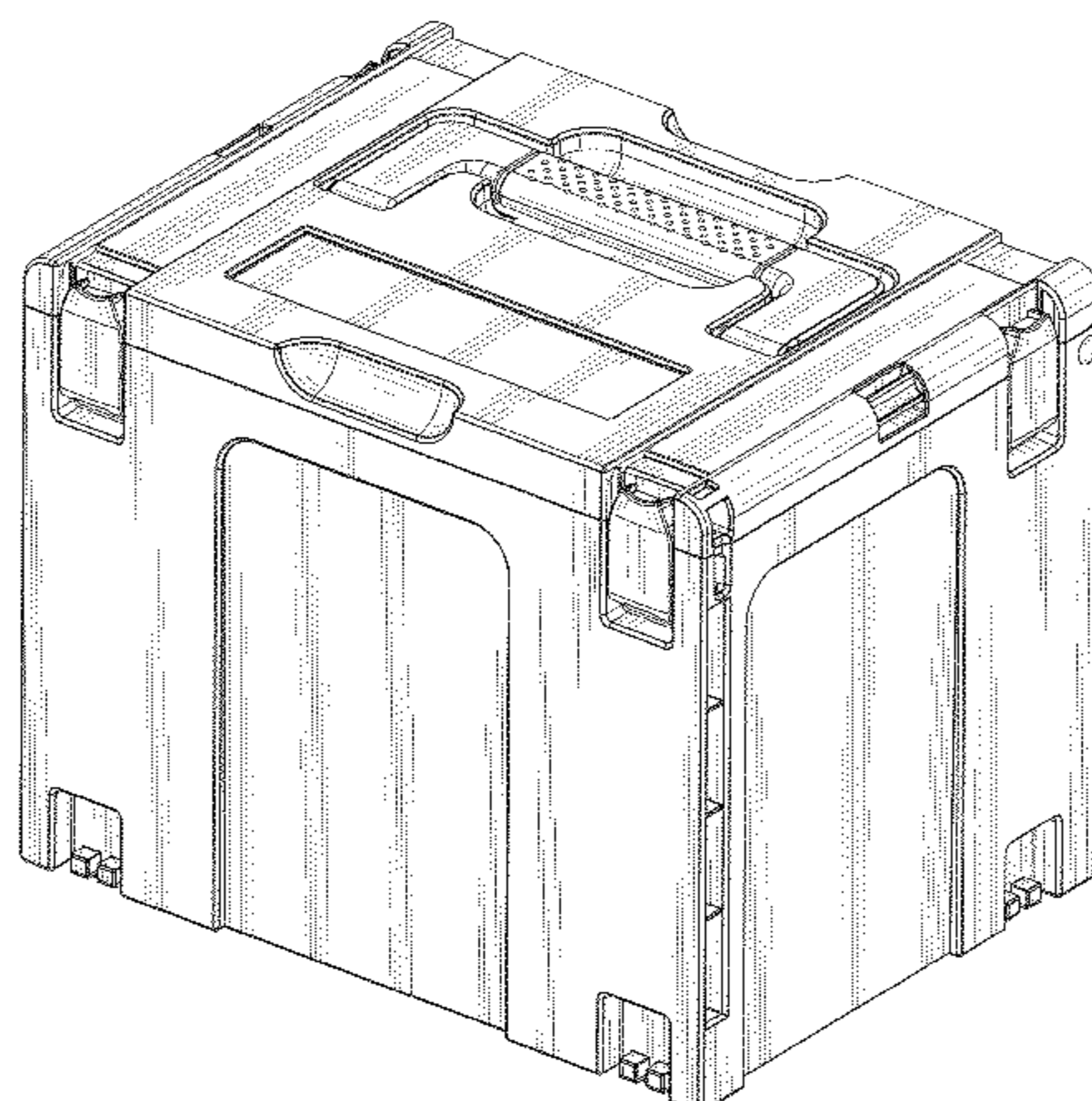

FIG. **11** is a left side elevational view of the tool box in accordance with the second embodiment of our new design; FIG. **12** is a top, front and right side perspective view of a tool box in accordance with a third embodiment of our new design;

FIG. **13** is a bottom, rear and right side perspective view of the tool box in accordance with the third embodiment of our new design;

FIG. **14** is a left side elevational view of the tool box in accordance with the third embodiment of our new design;

FIG. **15** is a top, front and right side perspective view of a tool box in accordance with a fourth embodiment of our new design;

FIG. **16** is a bottom, rear and right side perspective view of the tool box in accordance with the fourth embodiment of our new design;

FIG. **17** is a left side elevational view of the tool box in accordance with the fourth embodiment of our new design;

FIG. **18** is a top, front and right side perspective view of a tool box in accordance with a fifth embodiment of our new design; FIG. **19** is a bottom, rear and right side perspective view of the tool box in accordance with the fifth embodiment of our new design; and,

FIG. **20** is a left side elevational view of the tool box in accordance with the fifth embodiment of our new design.

The tool box according to the second and third embodiments illustrated in FIGS. **9-14** is the same as to the tool box according to the first embodiment illustrated in FIGS. **1-8** except that the number and height of the rectangular recesses formed on the rear, right side, and left side surfaces are different due to a difference in height of the tool box.

In FIGS. **18-20** illustrating the fifth embodiment, the tool box is shown broken away by a break line to illustrate an indeterminate height of the tool box. The precise height of the tool box is not being claimed in the fifth embodiment.

1 Claim, 20 Drawing Sheets

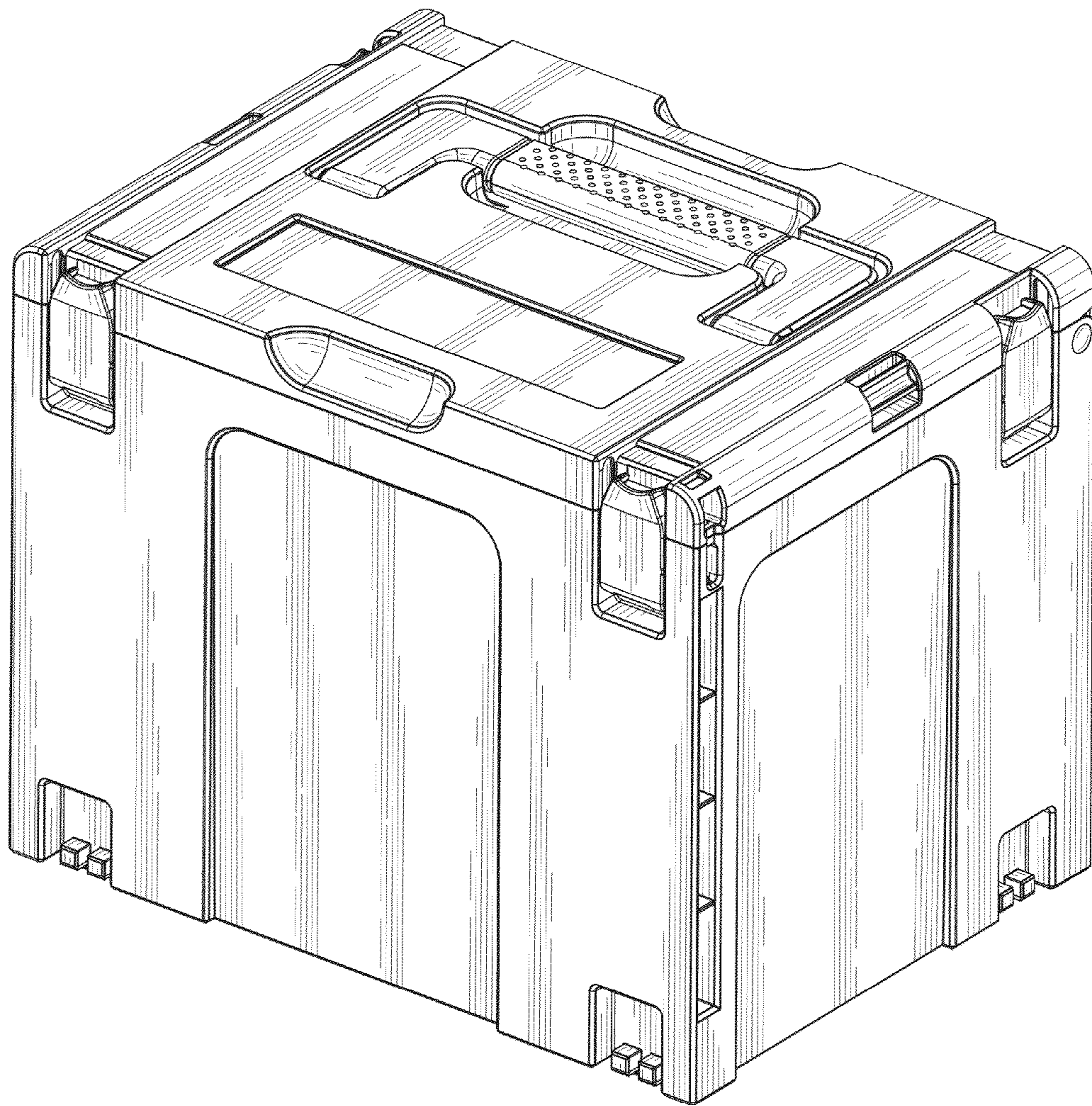

FIG. 1

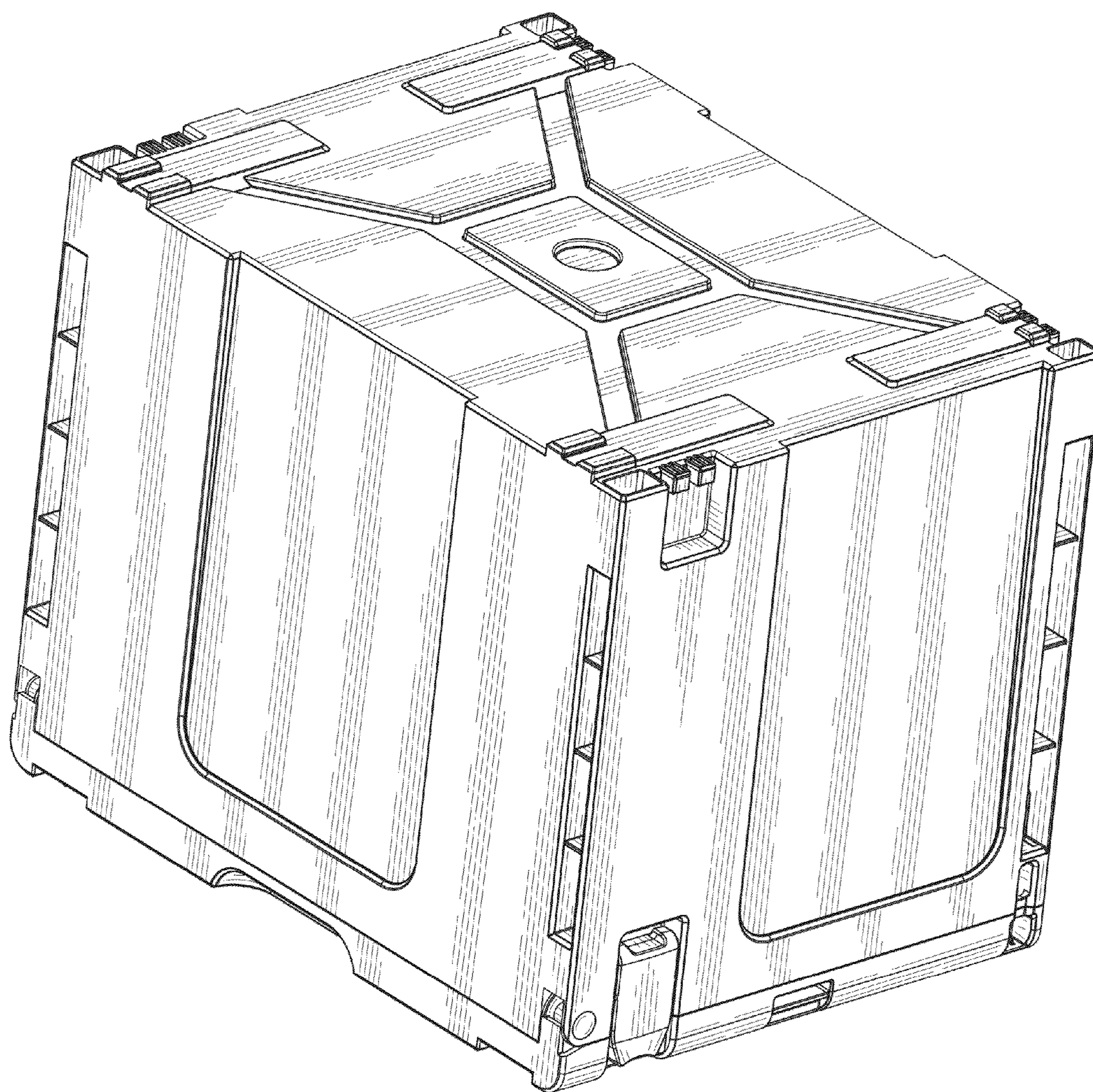

FIG. 2

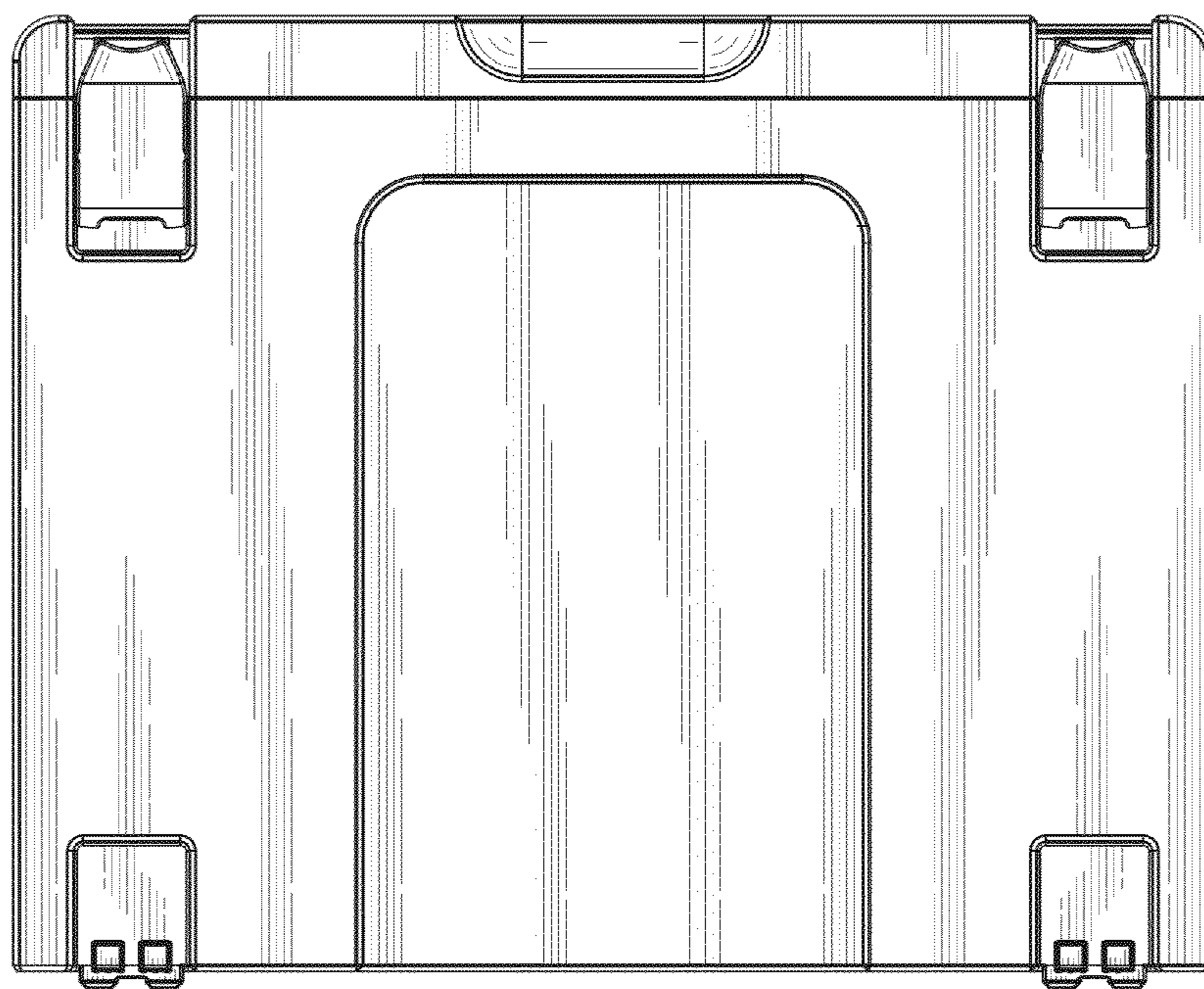

FIG. 3

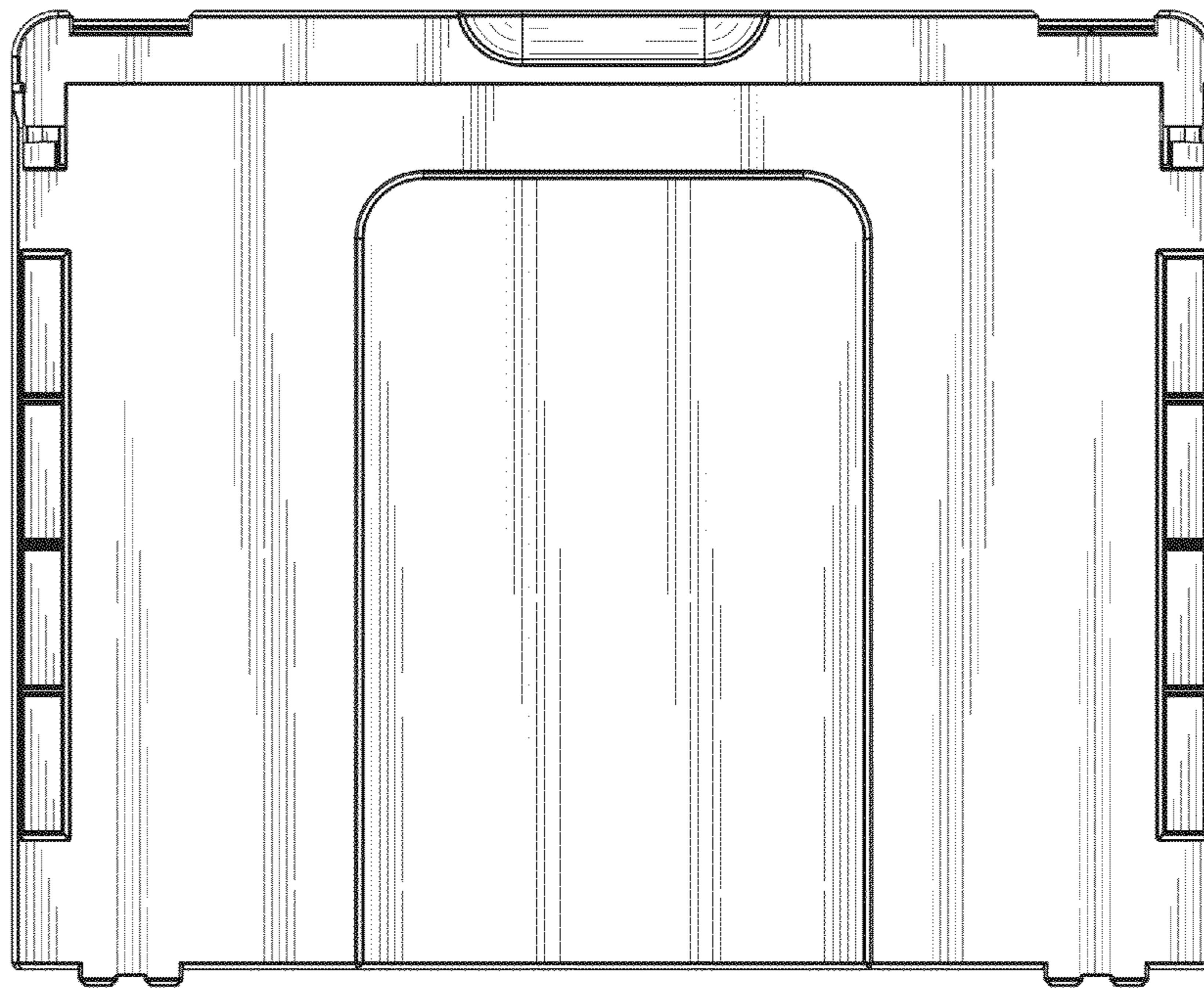

FIG. 4

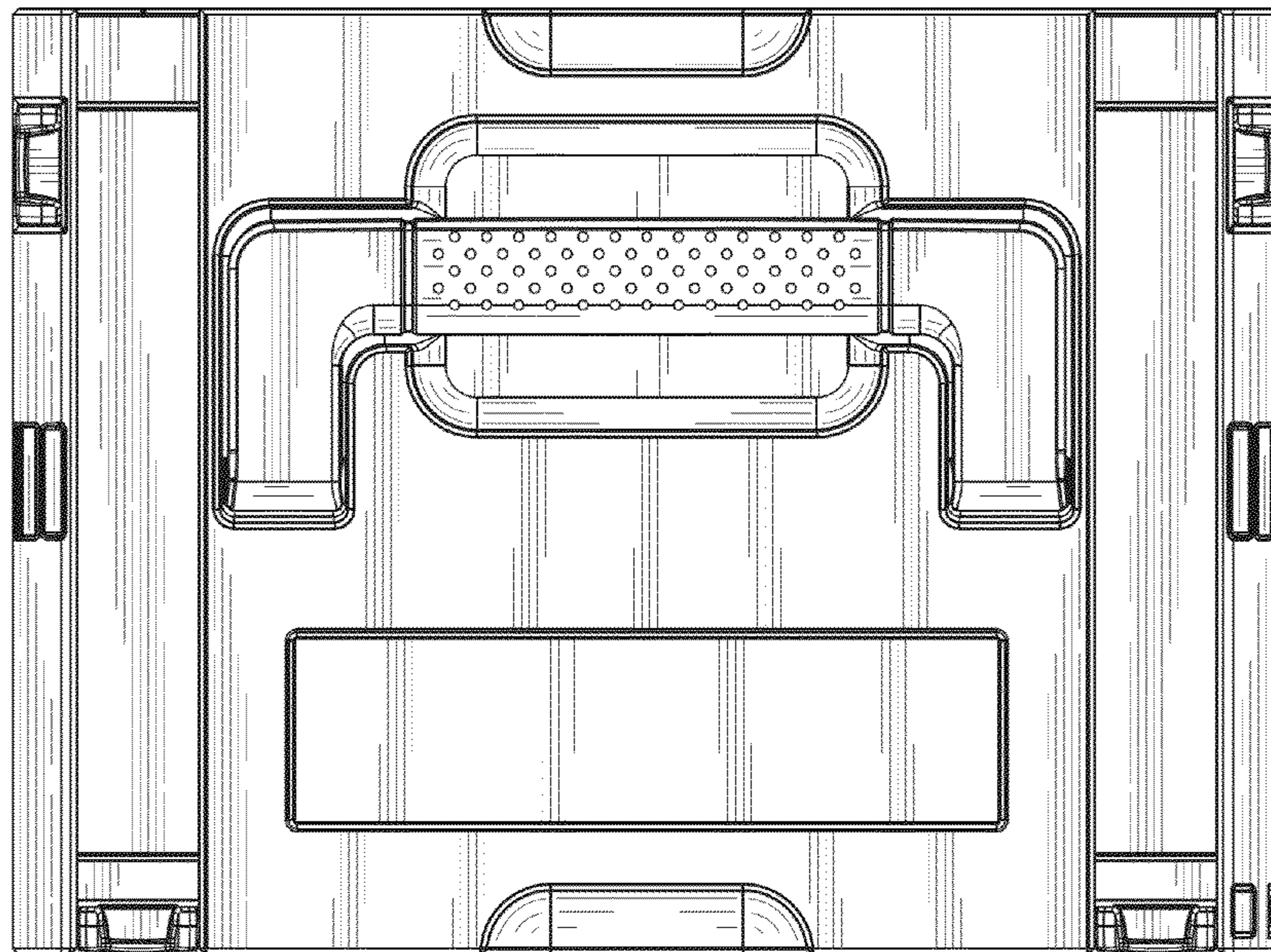

FIG. 5

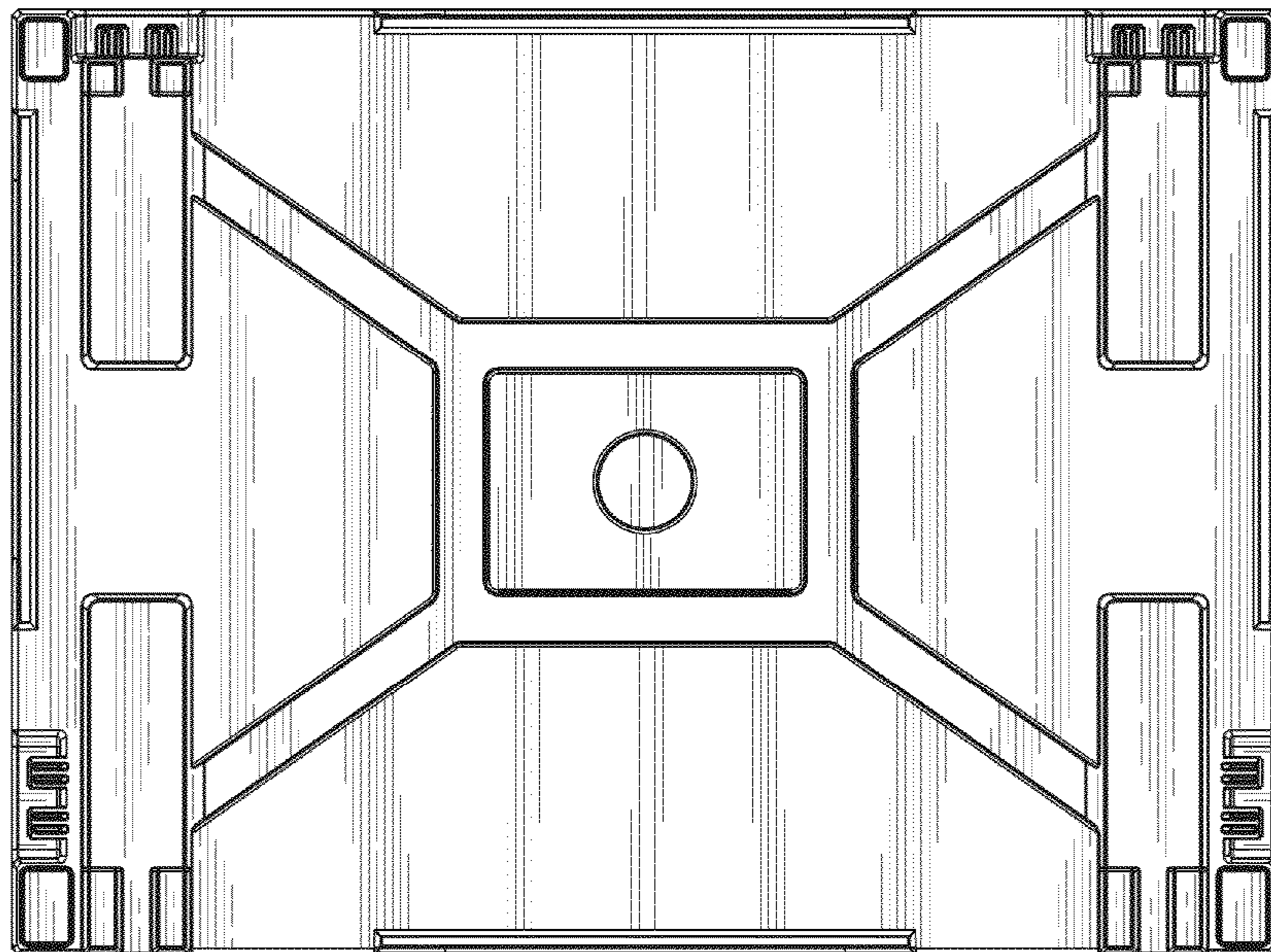

FIG. 6

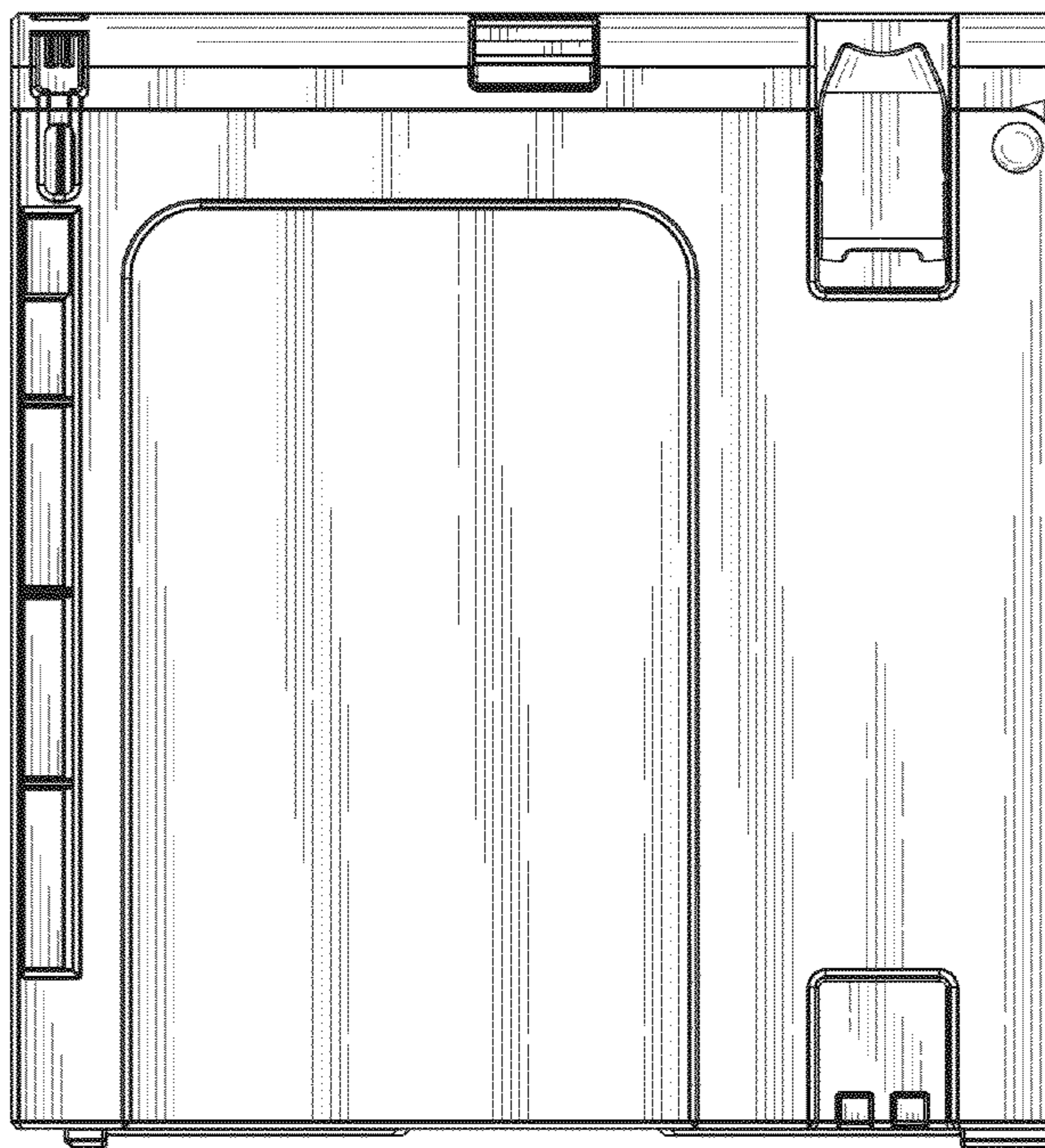

FIG. 7

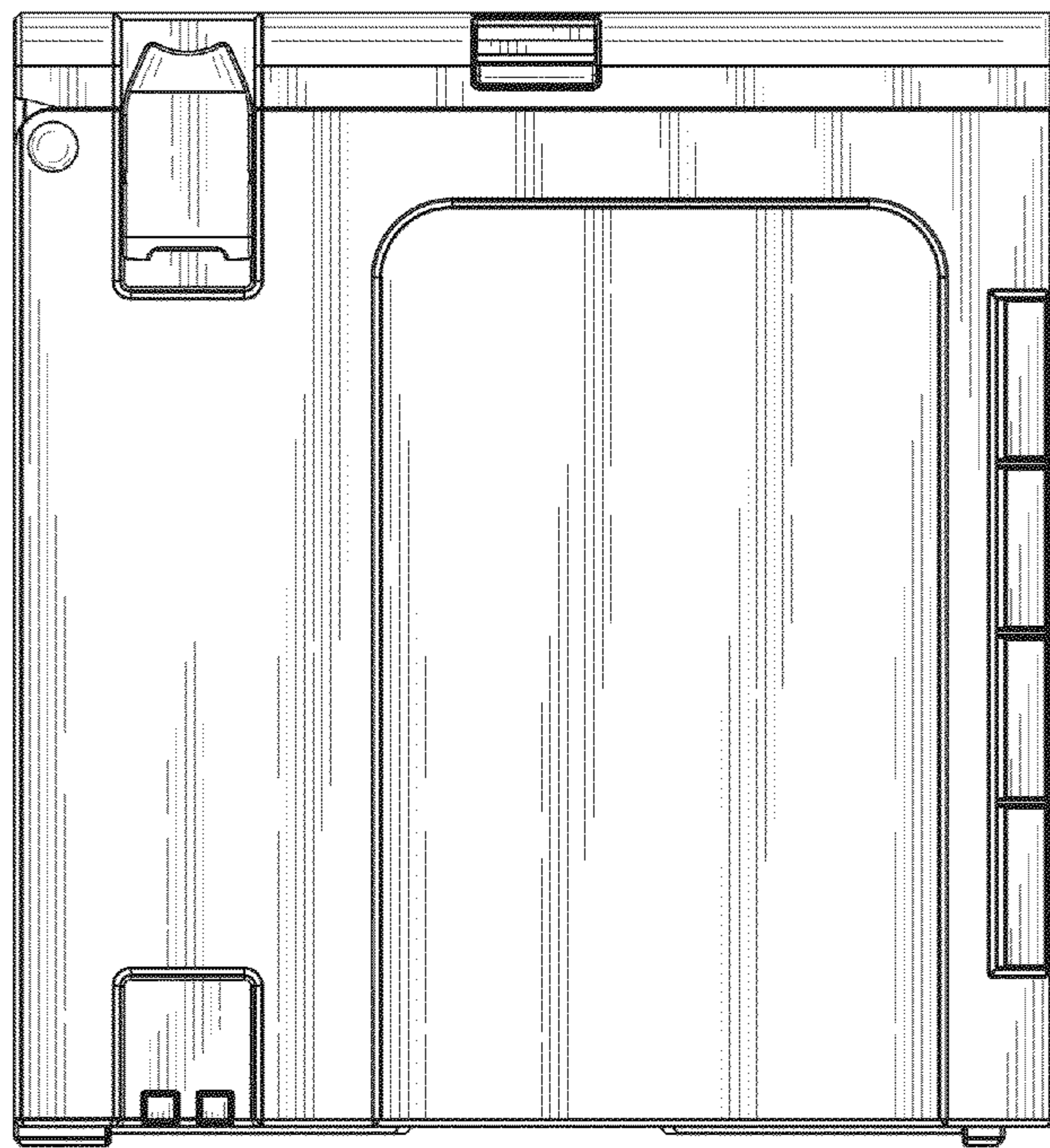

FIG. 8

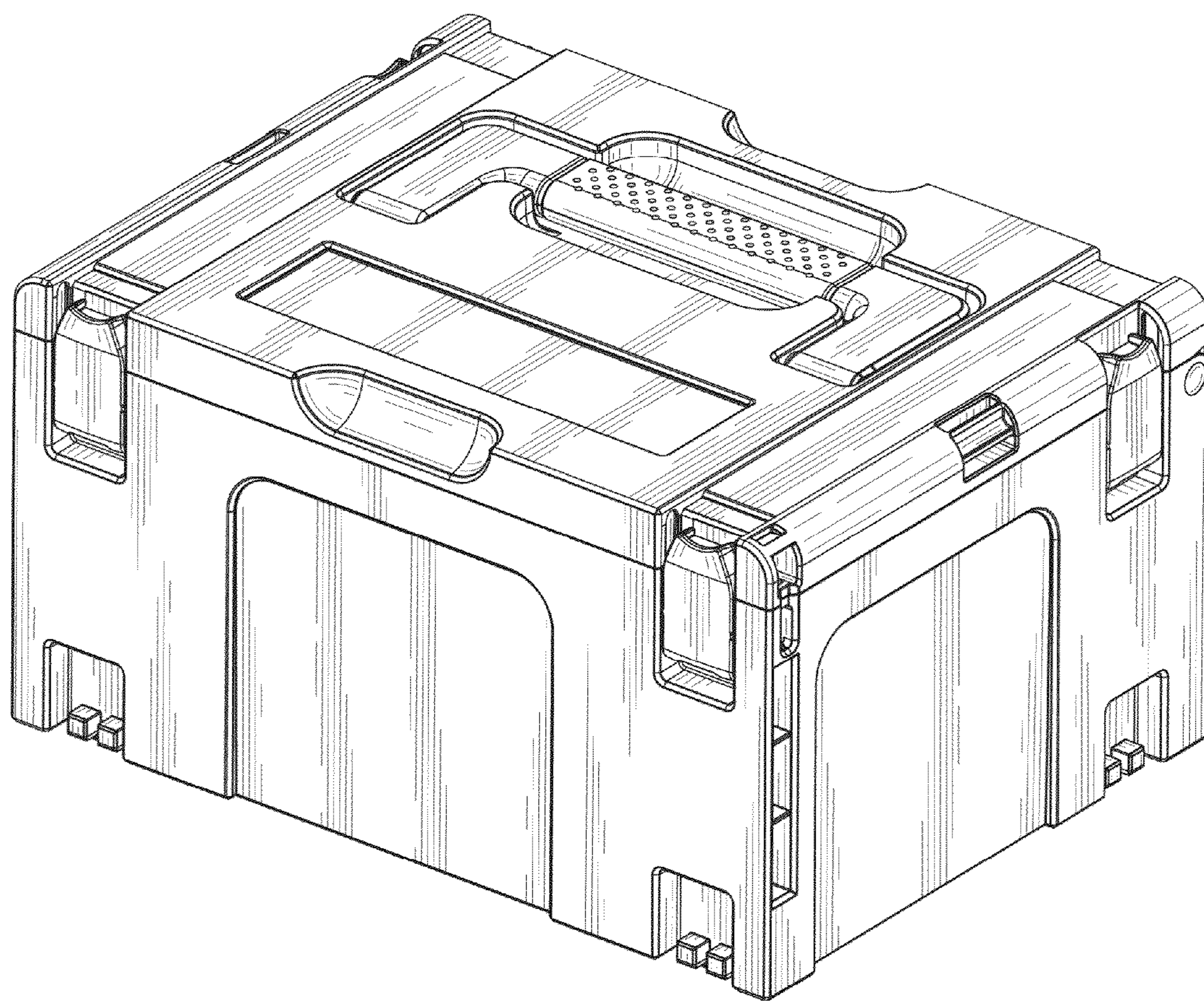

FIG. 9

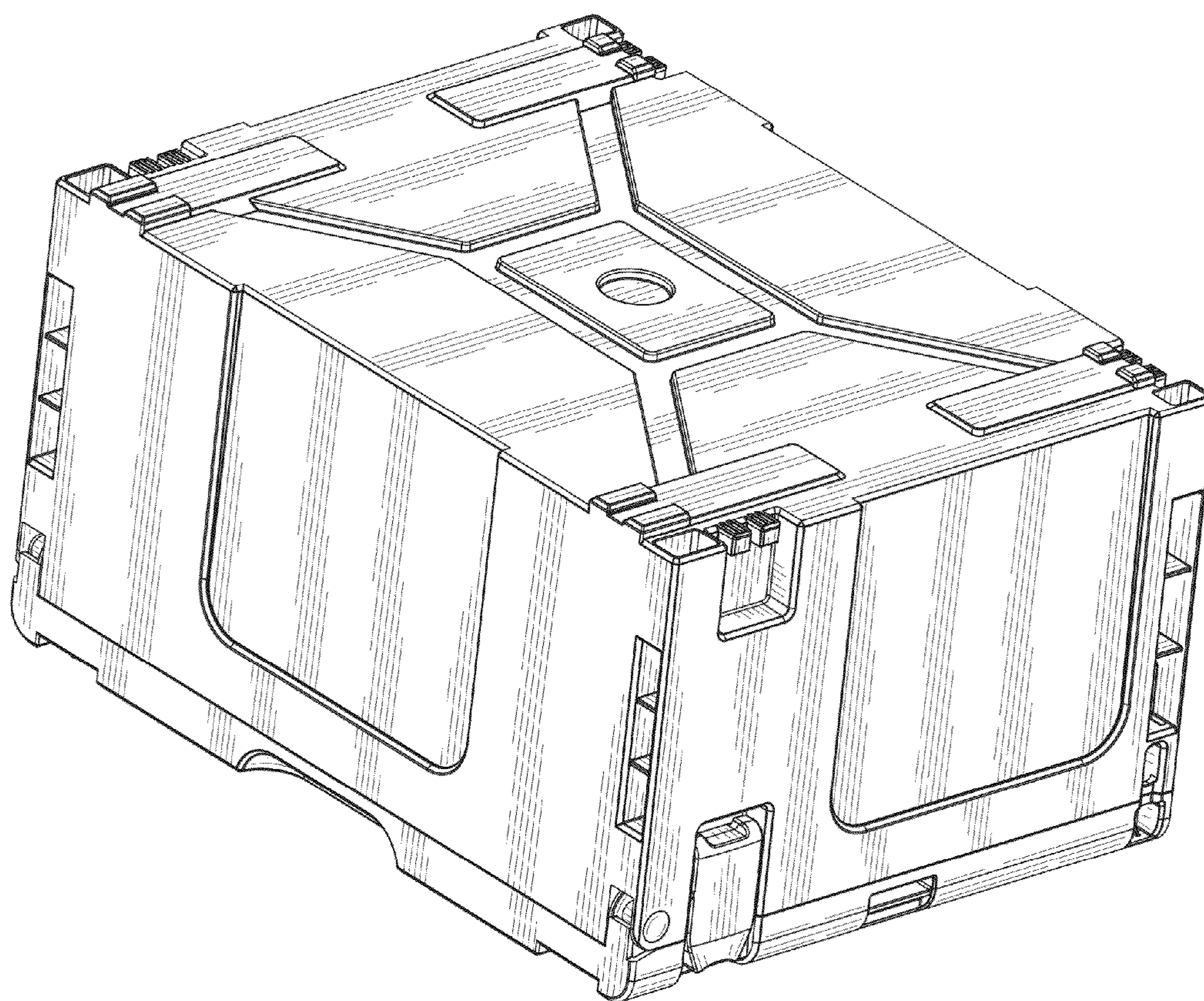

FIG. 10

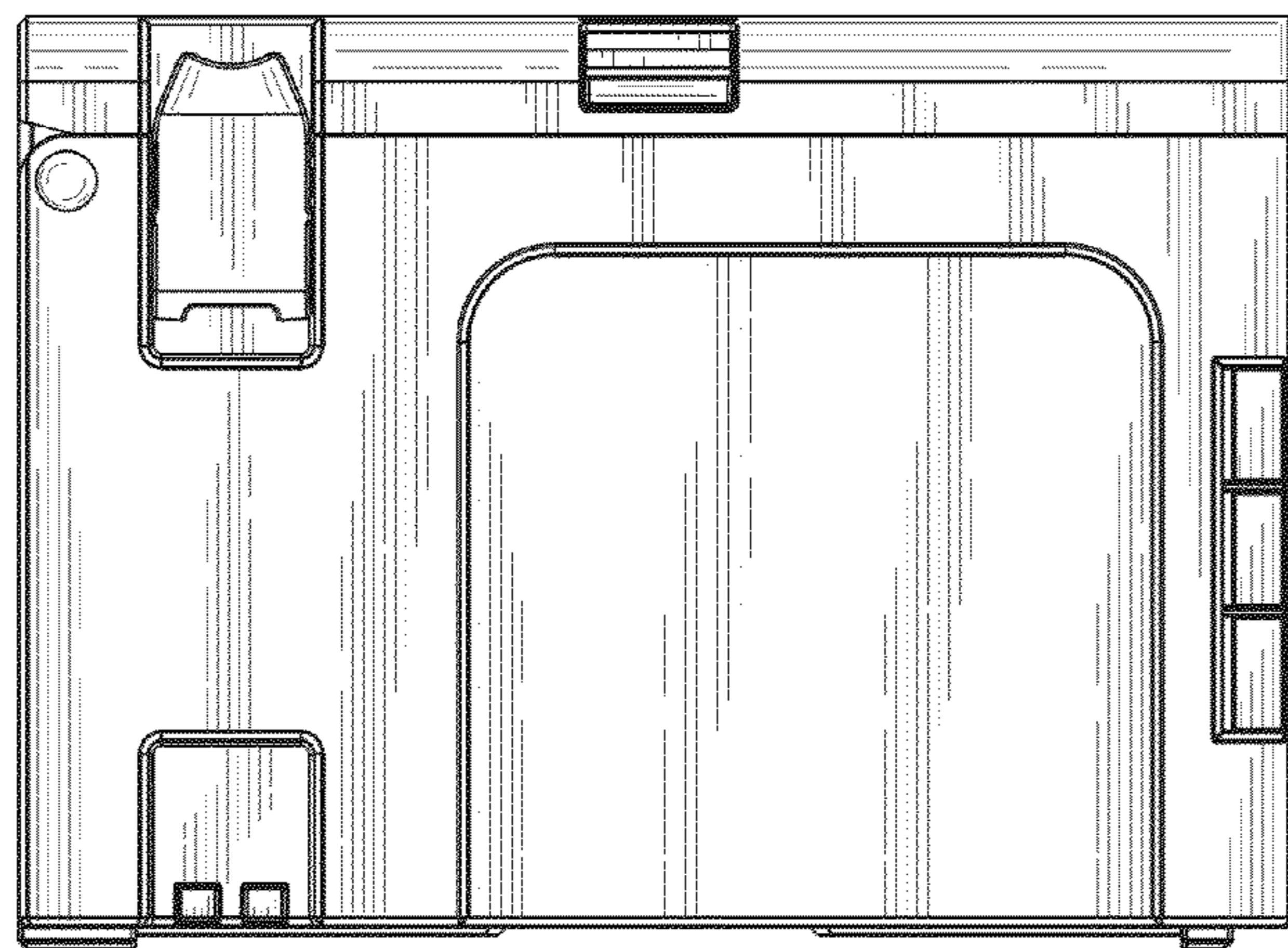

FIG. 11

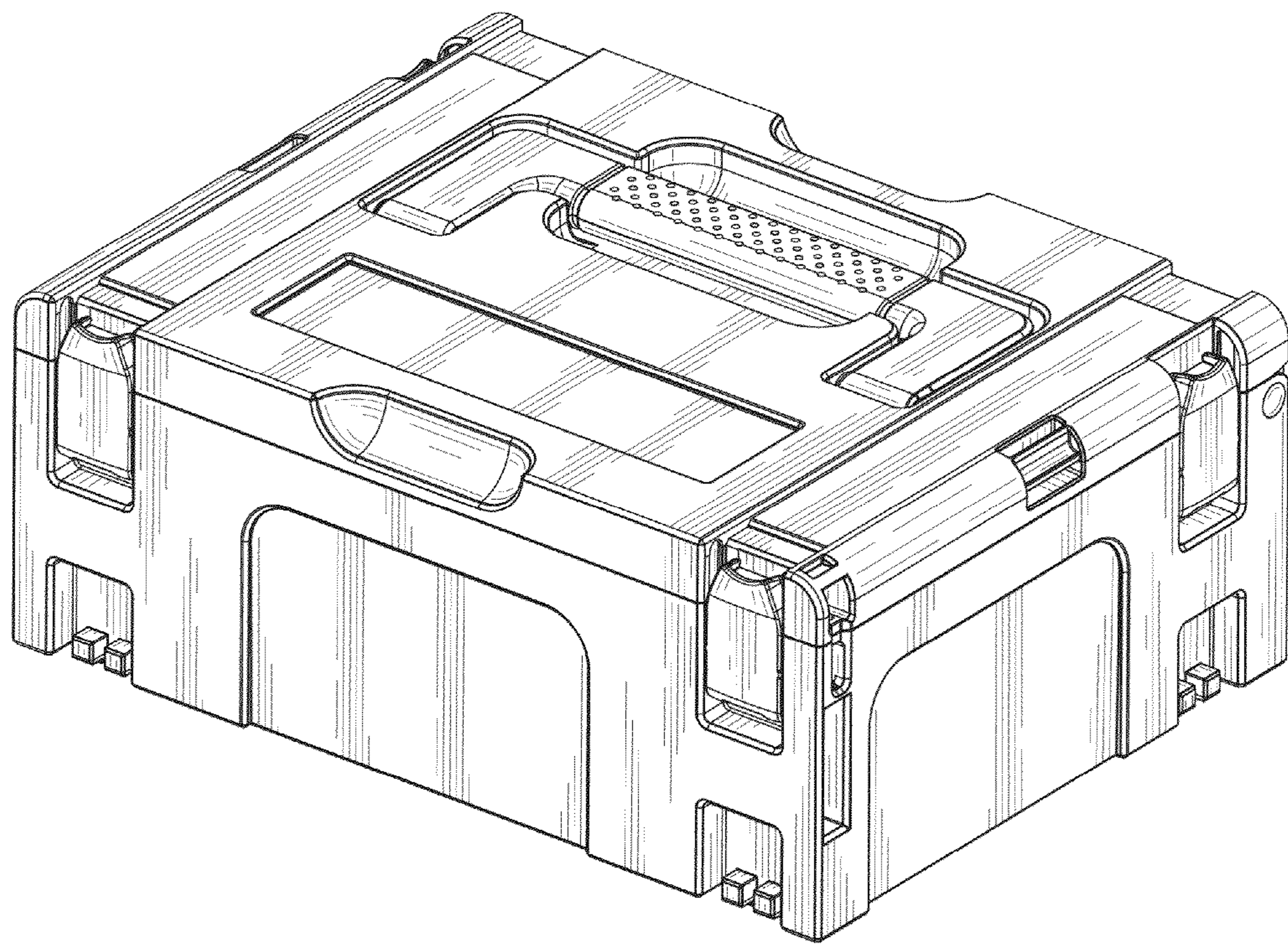

FIG. 12

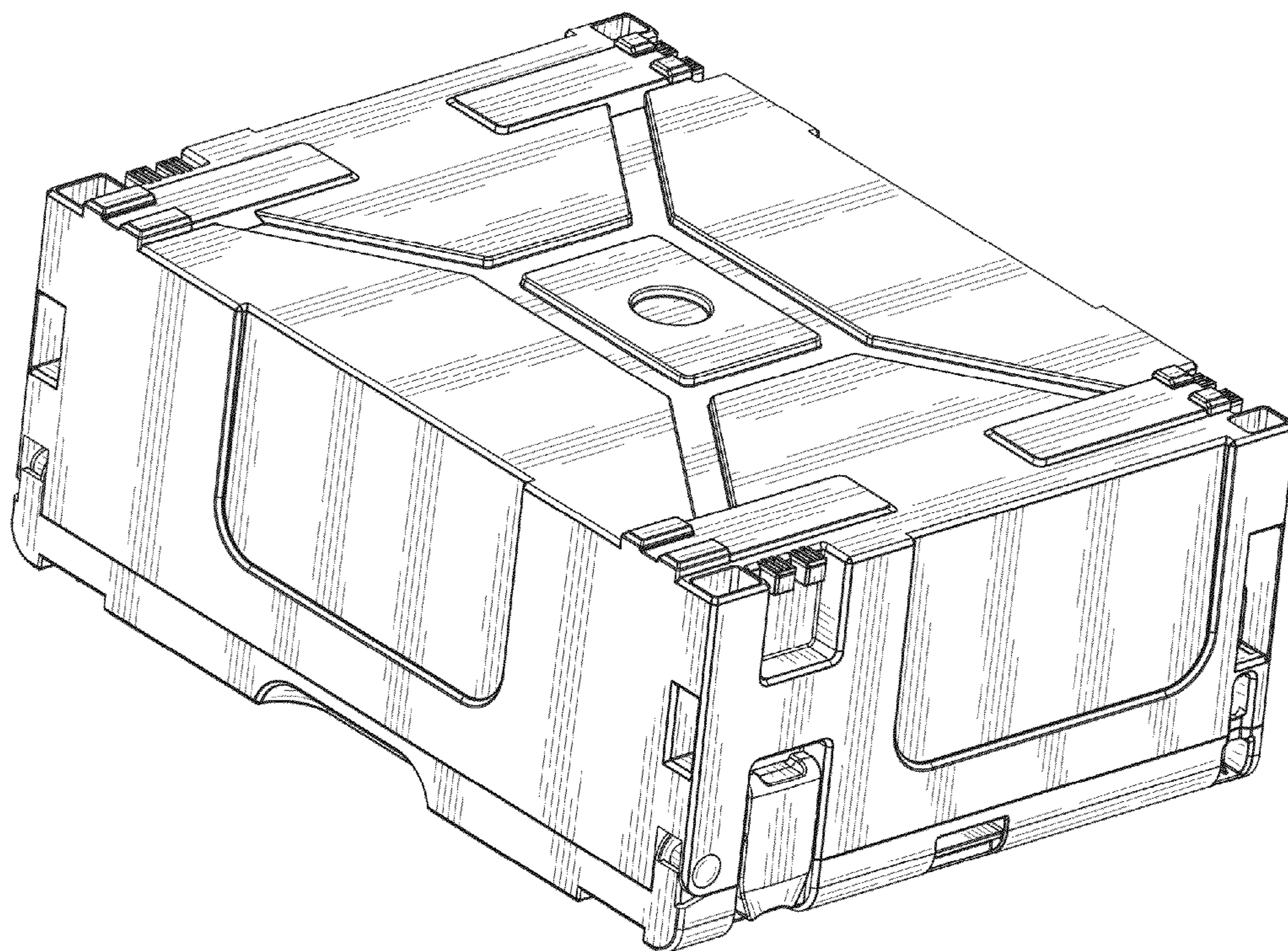

FIG. 13

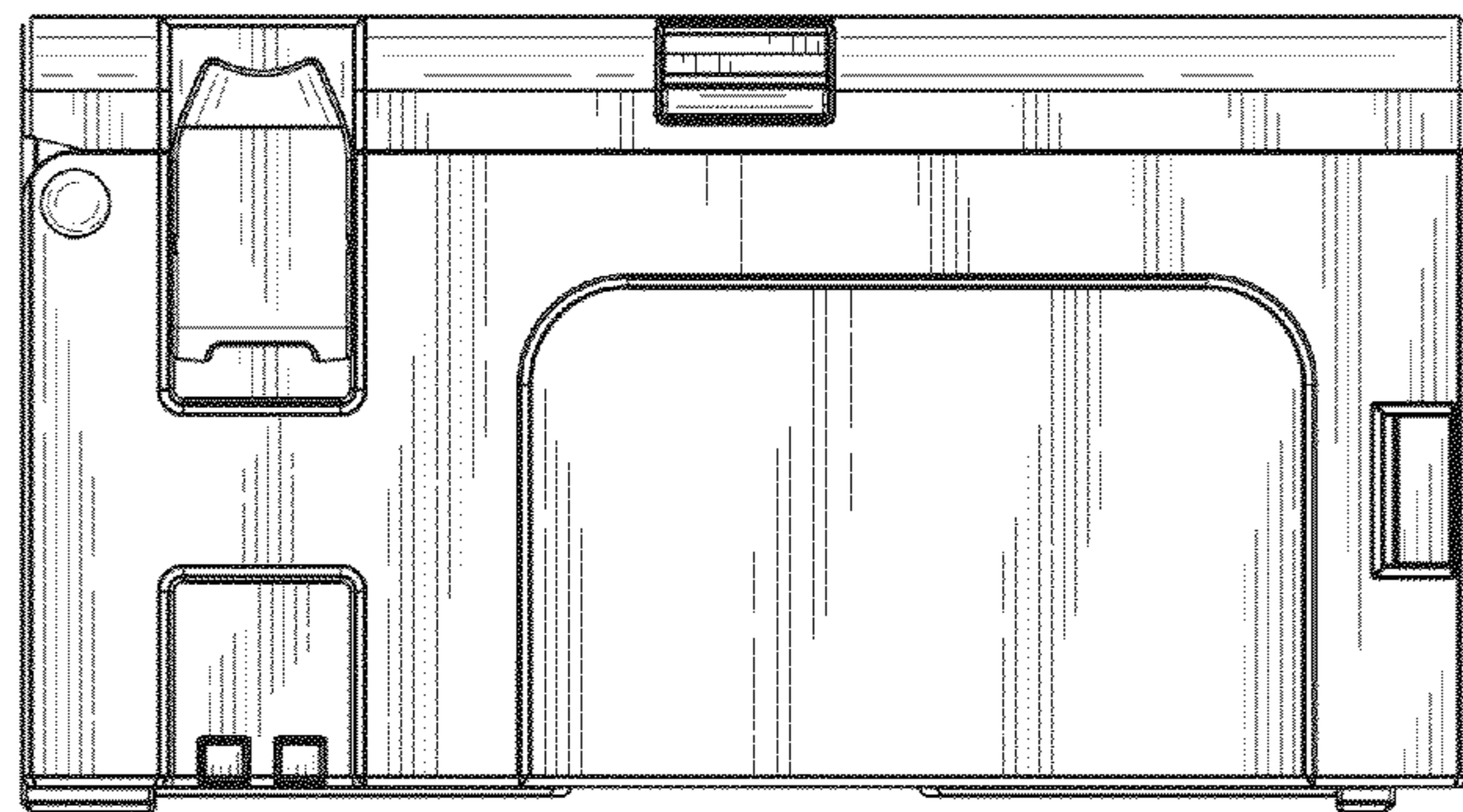

FIG. 14

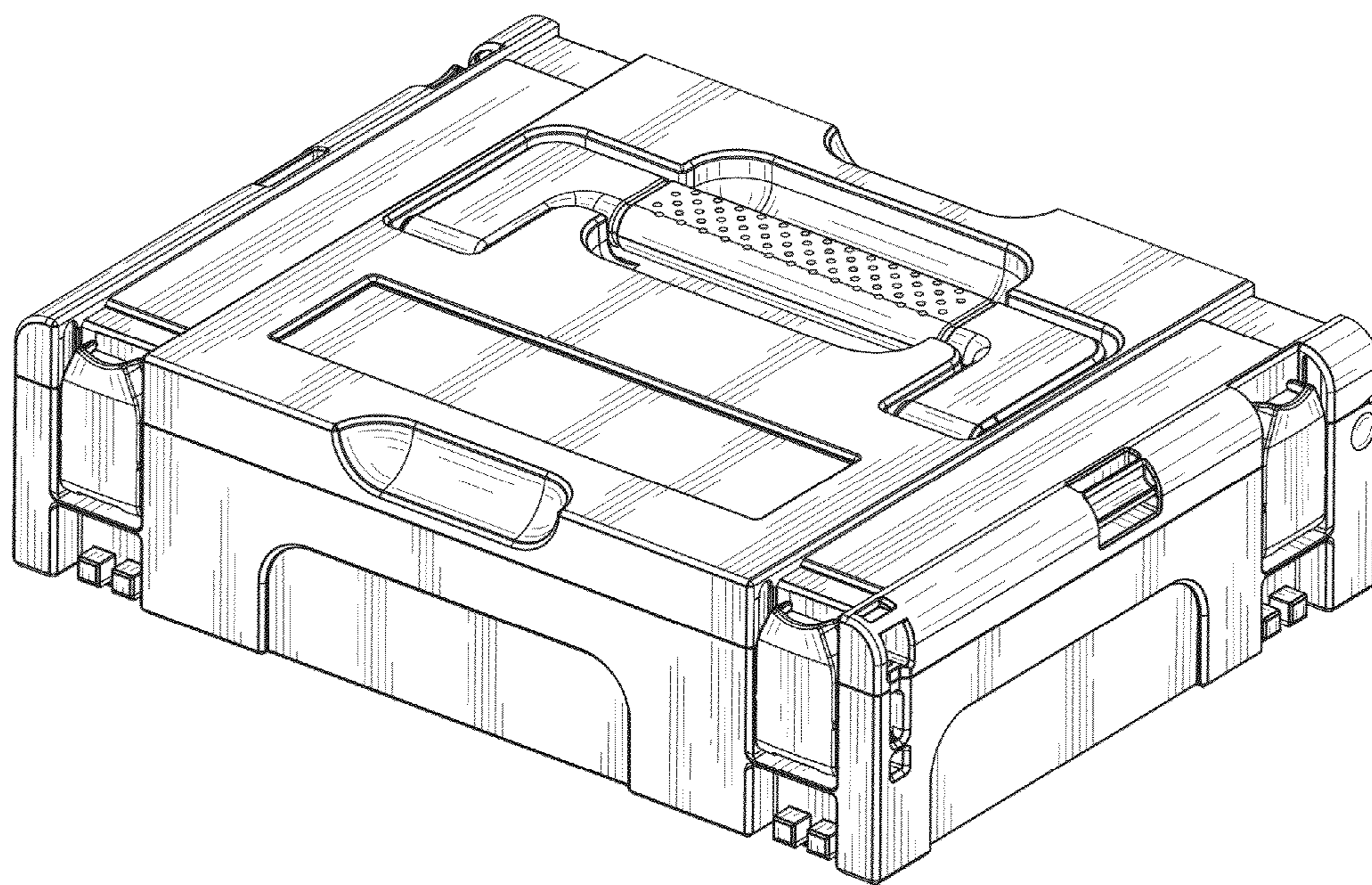

FIG. 15

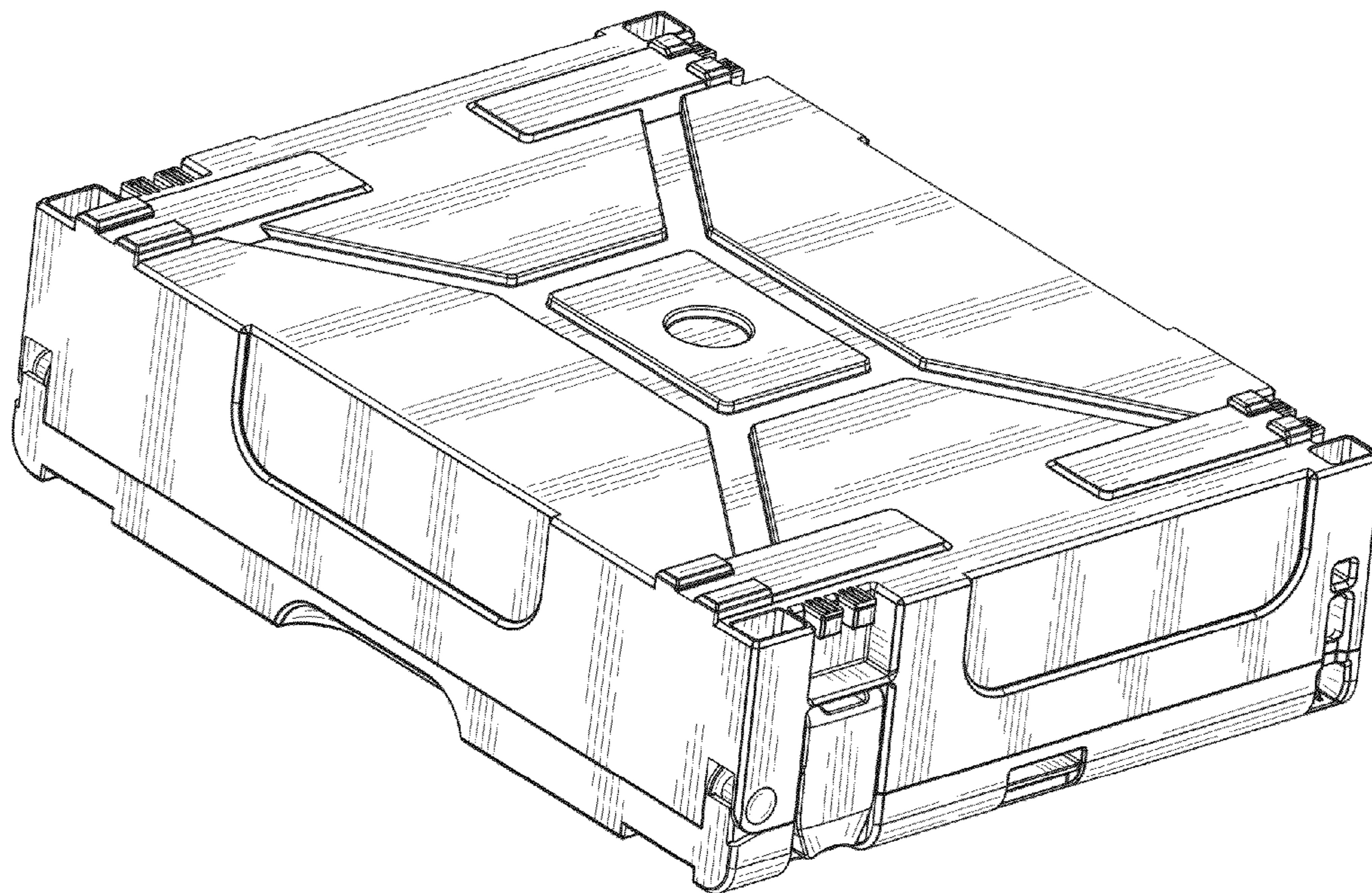

FIG. 16

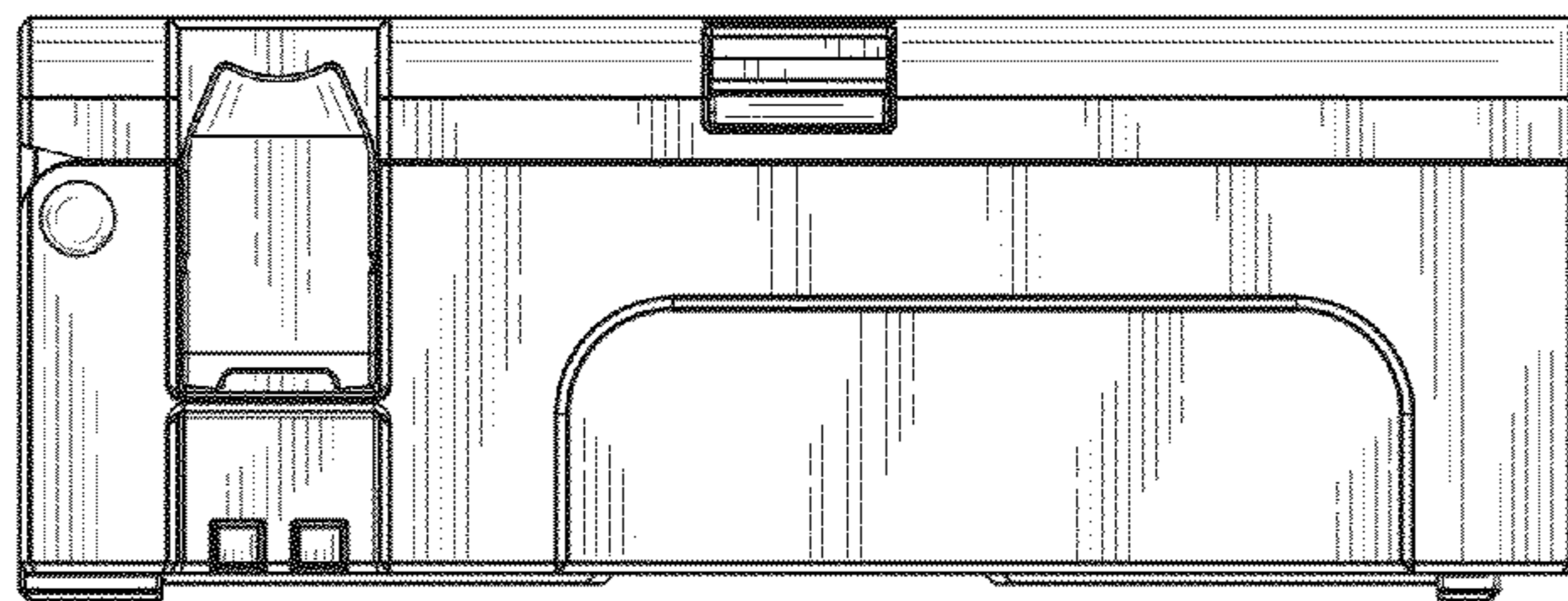

FIG. 17

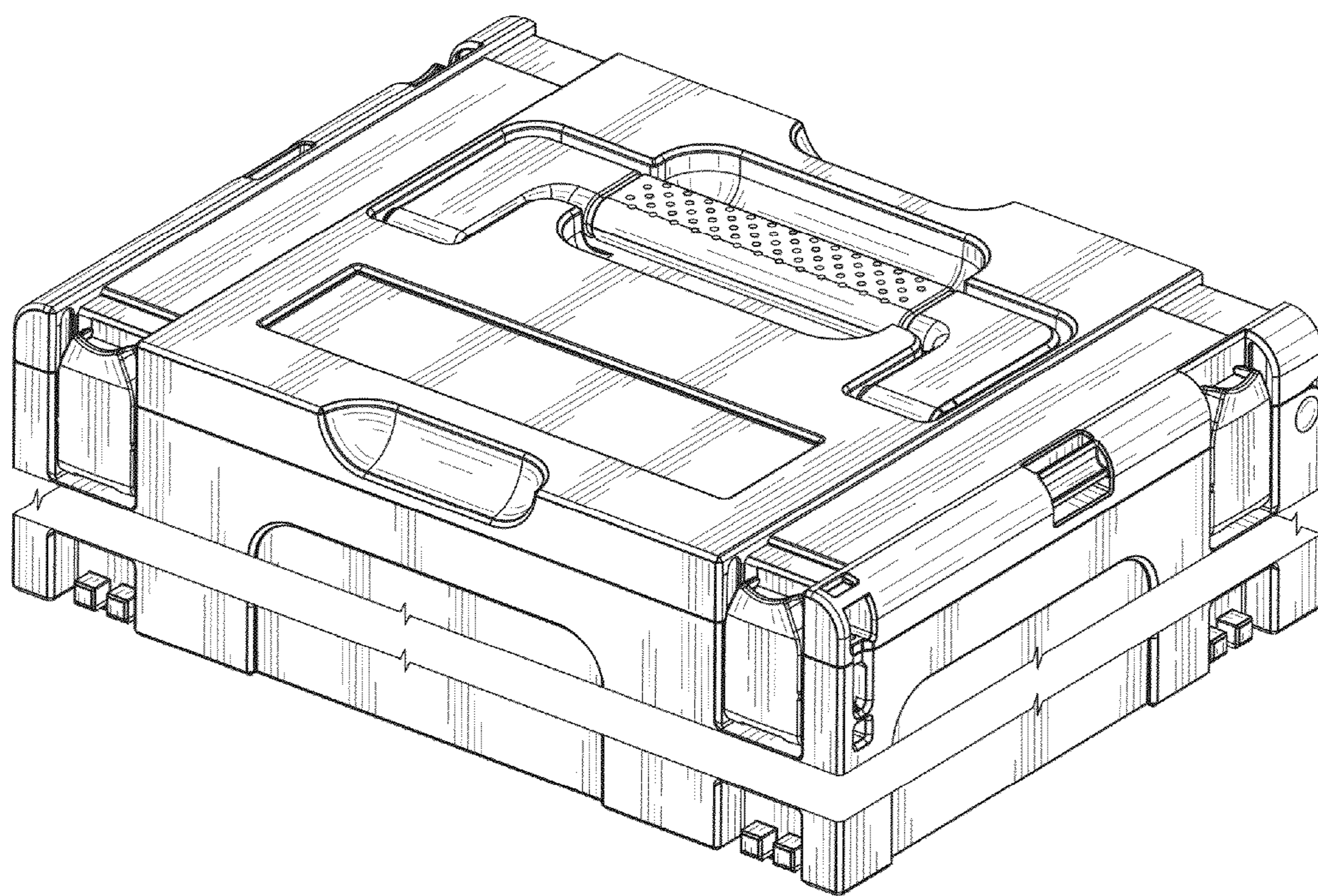

FIG. 18

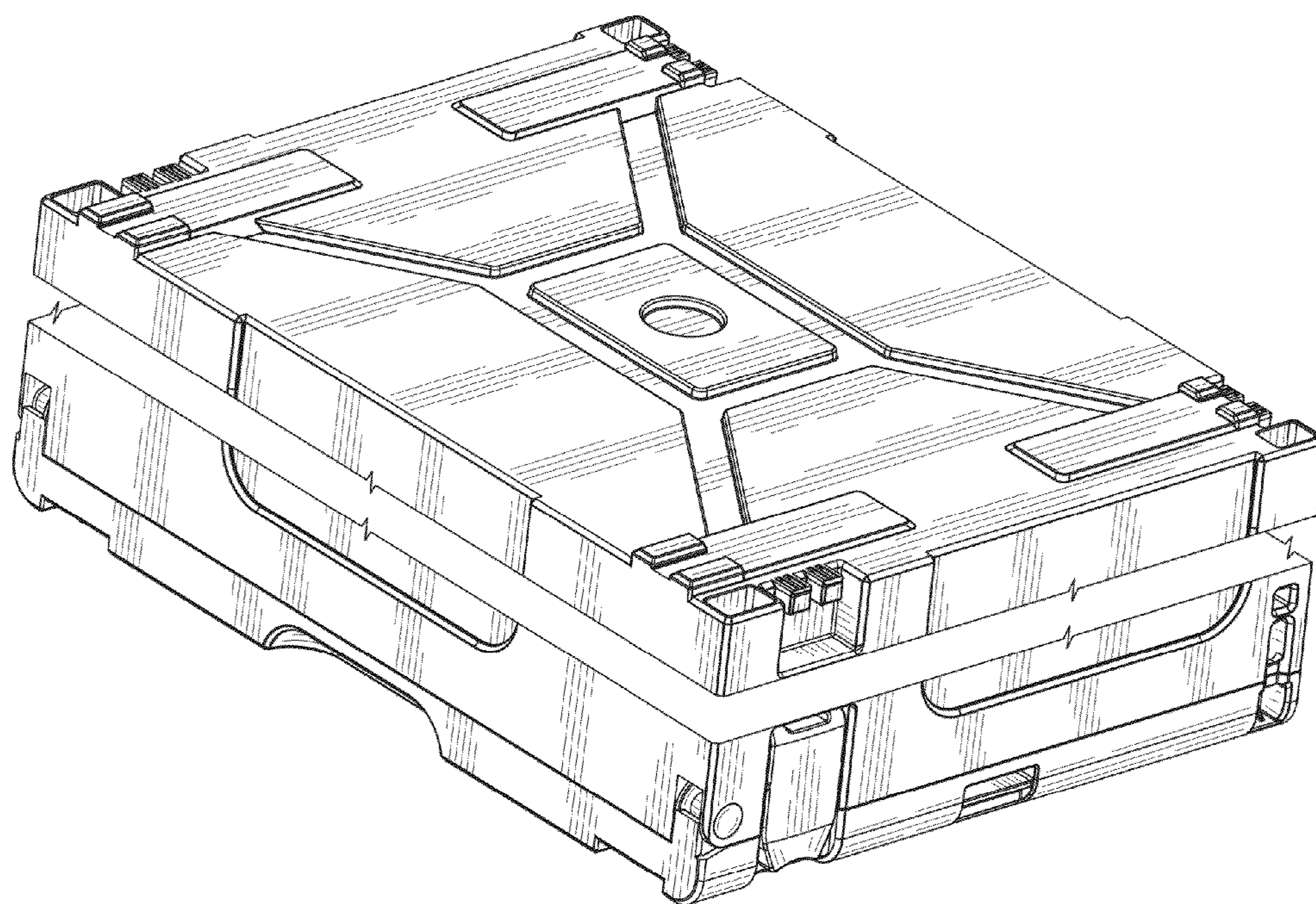

FIG. 19

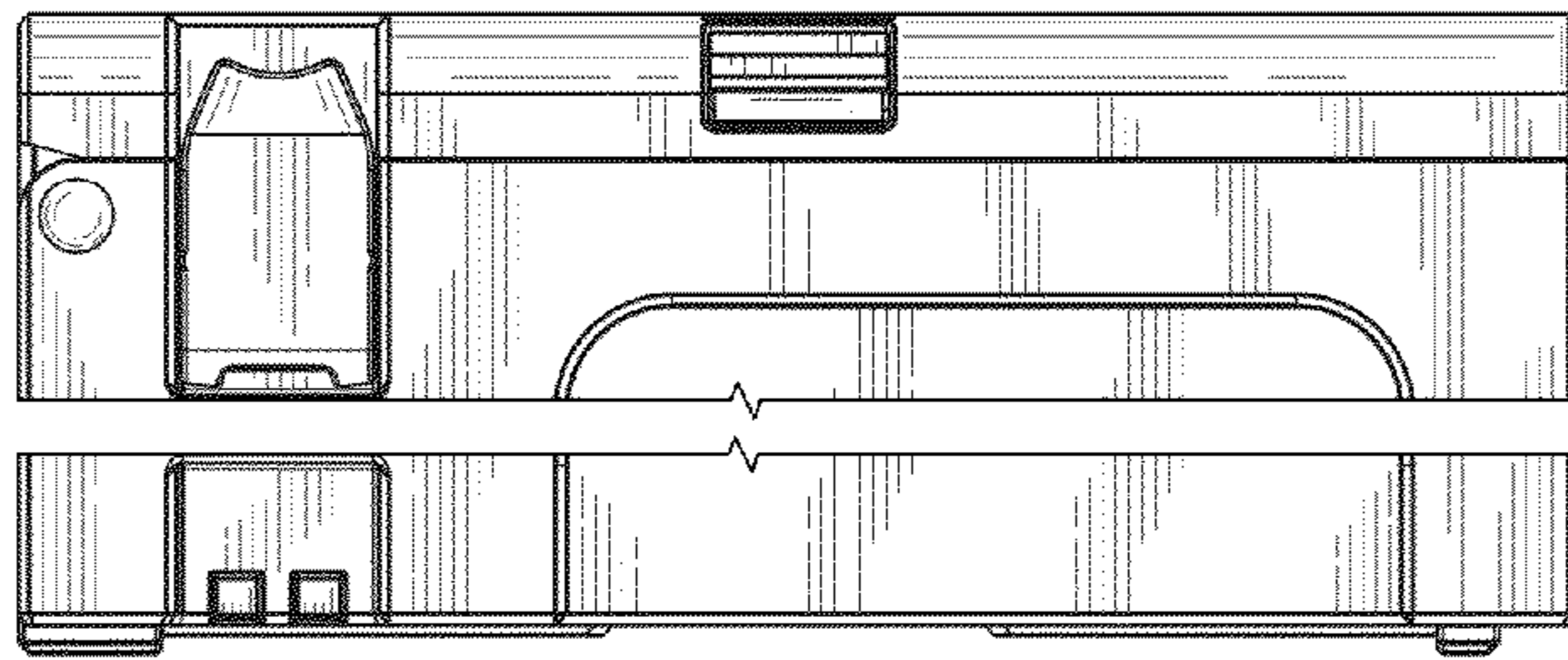

FIG. 20