

US00D668688S

(12) **United States Design Patent**  
**Kennard**

(10) **Patent No.:** **US D668,688 S**

(45) **Date of Patent:** **\*\* Oct. 9, 2012**

(54) **MIXER**

(75) **Inventor:** **Rory Campbell Kennard**, Naremburn (AU)

(73) **Assignee:** **Work Smart Equipment Pty Limited**, Artarmon, NSW (AU)

(\*\*) **Term:** **14 Years**

(21) **Appl. No.:** **29/401,602**

(22) **Filed:** **Sep. 13, 2011**

(51) **LOC (9) Cl.** ..... **15-03**

(52) **U.S. Cl.** ..... **D15/19**

(58) **Field of Classification Search** ..... D15/10,  
D15/19, 21, 147; 366/47, 48, 57, 60, 63,  
366/65, 181.3, 185, 193, 219, 228, 232, 241,  
366/242

See application file for complete search history.

(56) **References Cited**

**U.S. PATENT DOCUMENTS**

D192,102 S *	1/1962	Machovec	.....	D15/19
D196,638 S *	10/1963	Parker et al.	.....	D15/19
D219,171 S *	11/1970	Soldner	.....	D15/19
D221,591 S *	8/1971	Cooper	.....	D15/19
D241,887 S *	10/1976	Schulick	.....	D7/368
D245,006 S *	7/1977	Mills	.....	D15/19
D246,715 S *	12/1977	Clement	.....	D15/19
D256,800 S *	9/1980	Deen et al.	.....	D15/19

D260,150 S *	8/1981	Palmer	.....	D15/19
D268,586 S *	4/1983	Baum	.....	D15/19
5,261,744 A *	11/1993	Brunn	.....	366/217
D354,289 S *	1/1995	Fortenberry et al.	.....	D15/19
5,456,416 A *	10/1995	Hartwig	.....	241/260.1
5,868,494 A *	2/1999	Campbell et al.	.....	366/47
D421,613 S *	3/2000	Shiotani	.....	D15/19
D477,331 S *	7/2003	Tsai	.....	D15/19
D504,135 S *	4/2005	Simpson et al.	.....	D15/19
D527,391 S *	8/2006	Coli	.....	D15/19
D534,551 S *	1/2007	Kushlan	.....	D15/19
D552,627 S *	10/2007	Watson	.....	D15/19
D555,672 S *	11/2007	Watson	.....	D15/19

\* cited by examiner

*Primary Examiner* — Mark Goodwin

(74) *Attorney, Agent, or Firm* — James Creighton Wray

(57) **CLAIM**

The design for a mixer, as shown and described.

**DESCRIPTION**

FIG. 1 is a perspective view of the mixer showing the back, left side and top of the mixer.

FIG. 2 is a front elevation of the mixer shown in FIG. 1.

FIG. 3 is a right side elevation of the mixer.

FIG. 4 is a left side elevation of the mixer.

FIG. 5 is a back view of the mixer.

FIG. 6 is a top plan view of the mixer; and,

FIG. 7 is a bottom view of the mixer.

**1 Claim, 7 Drawing Sheets**

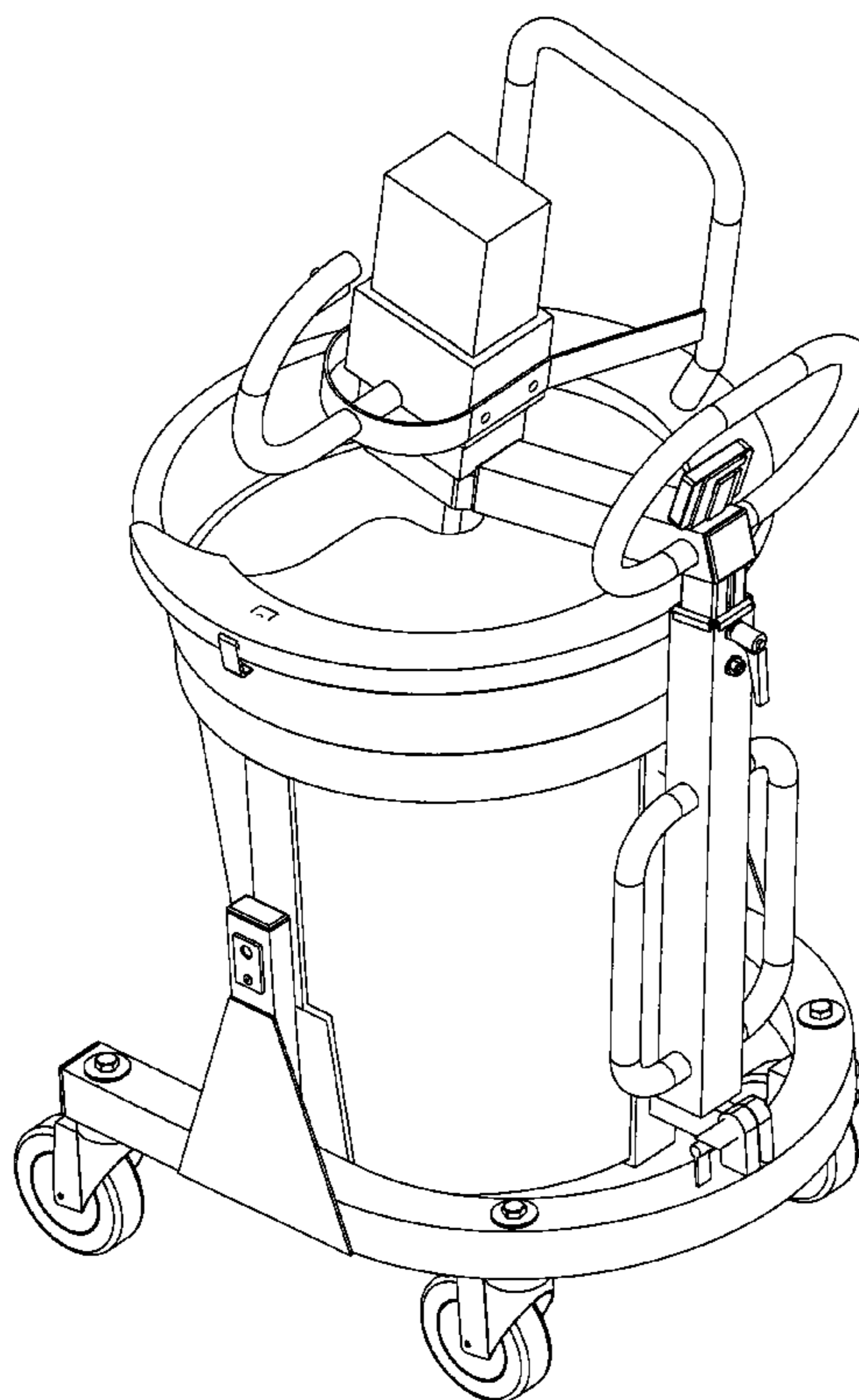

FIG. 1

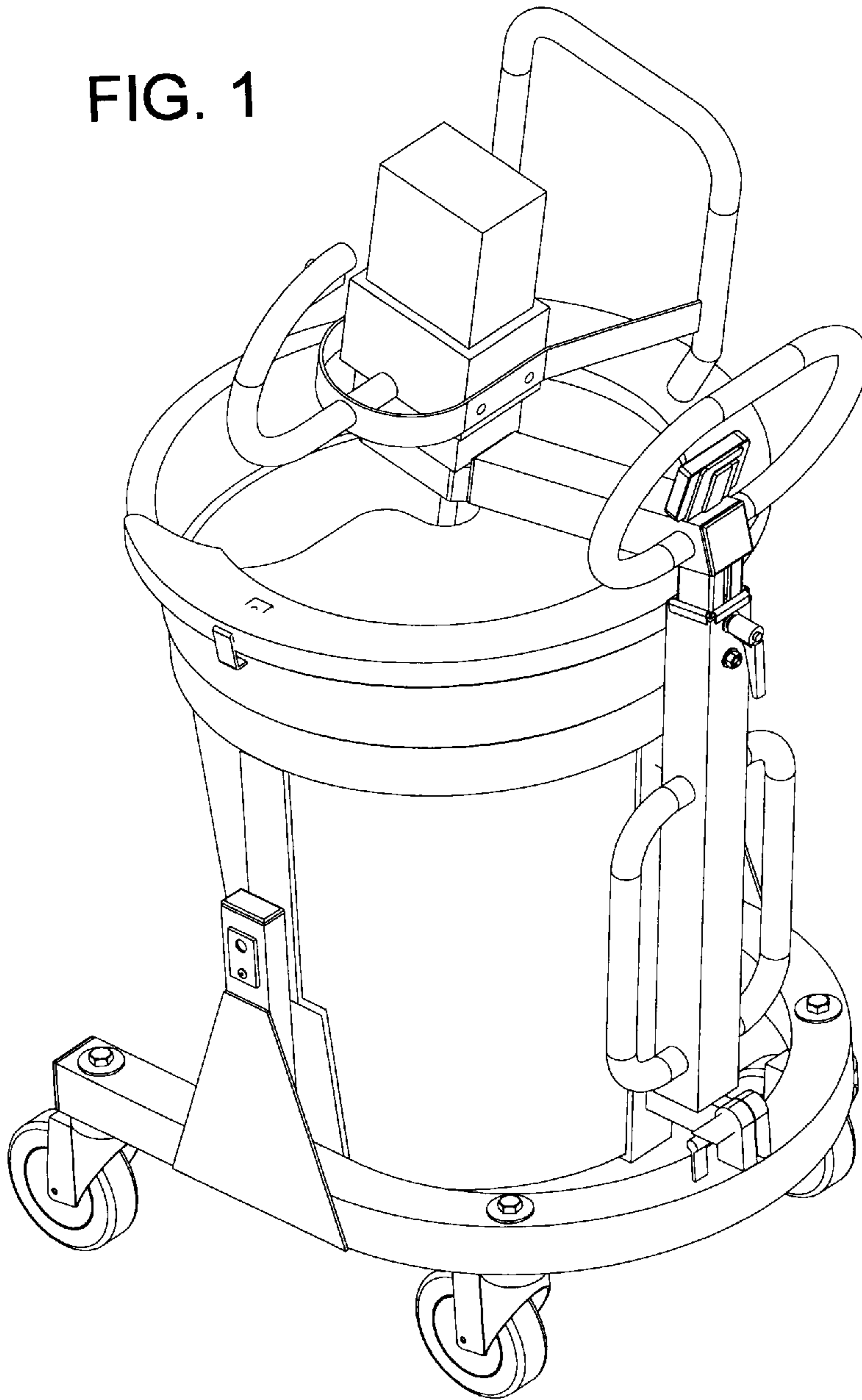
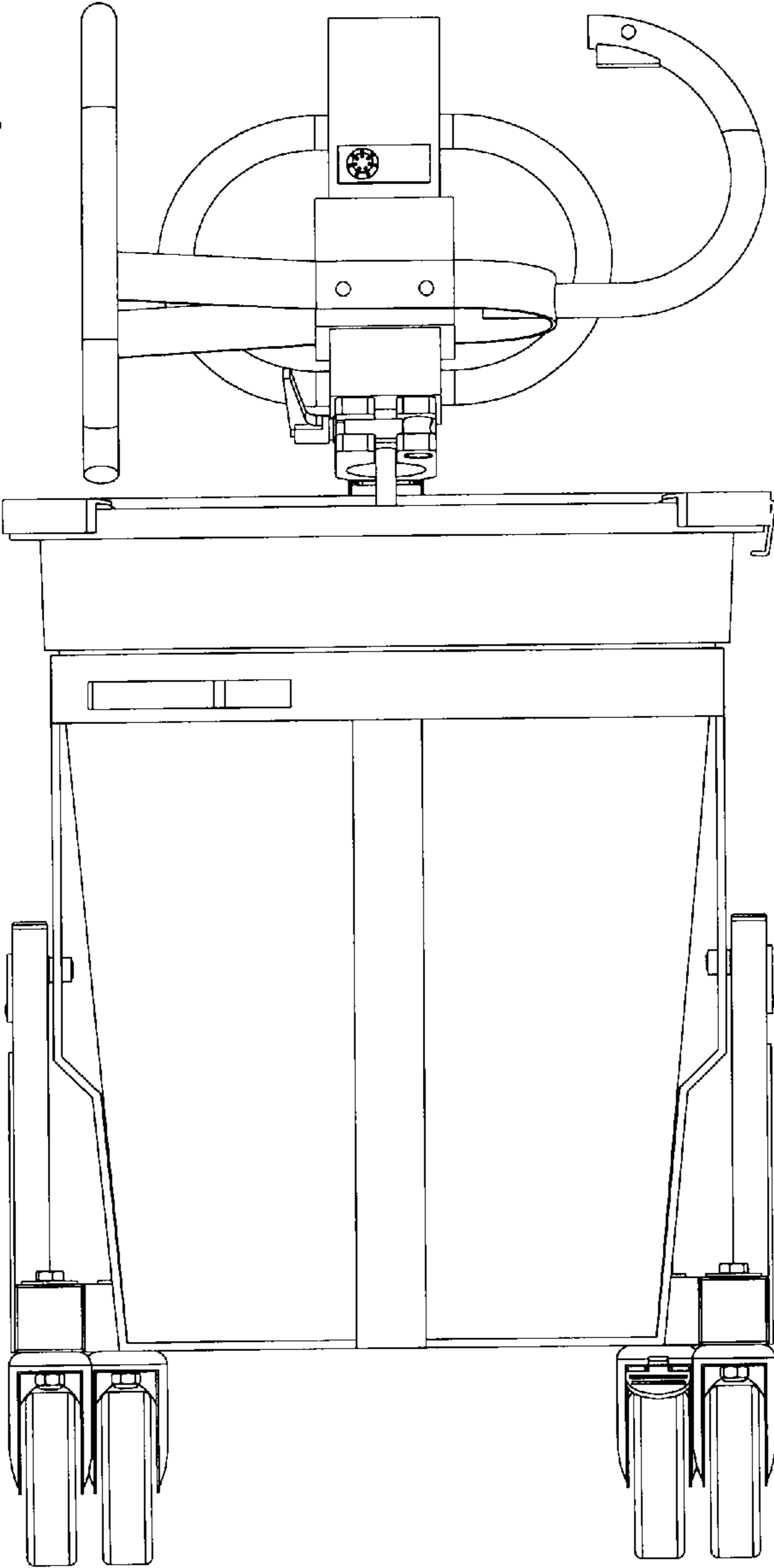

FIG. 2



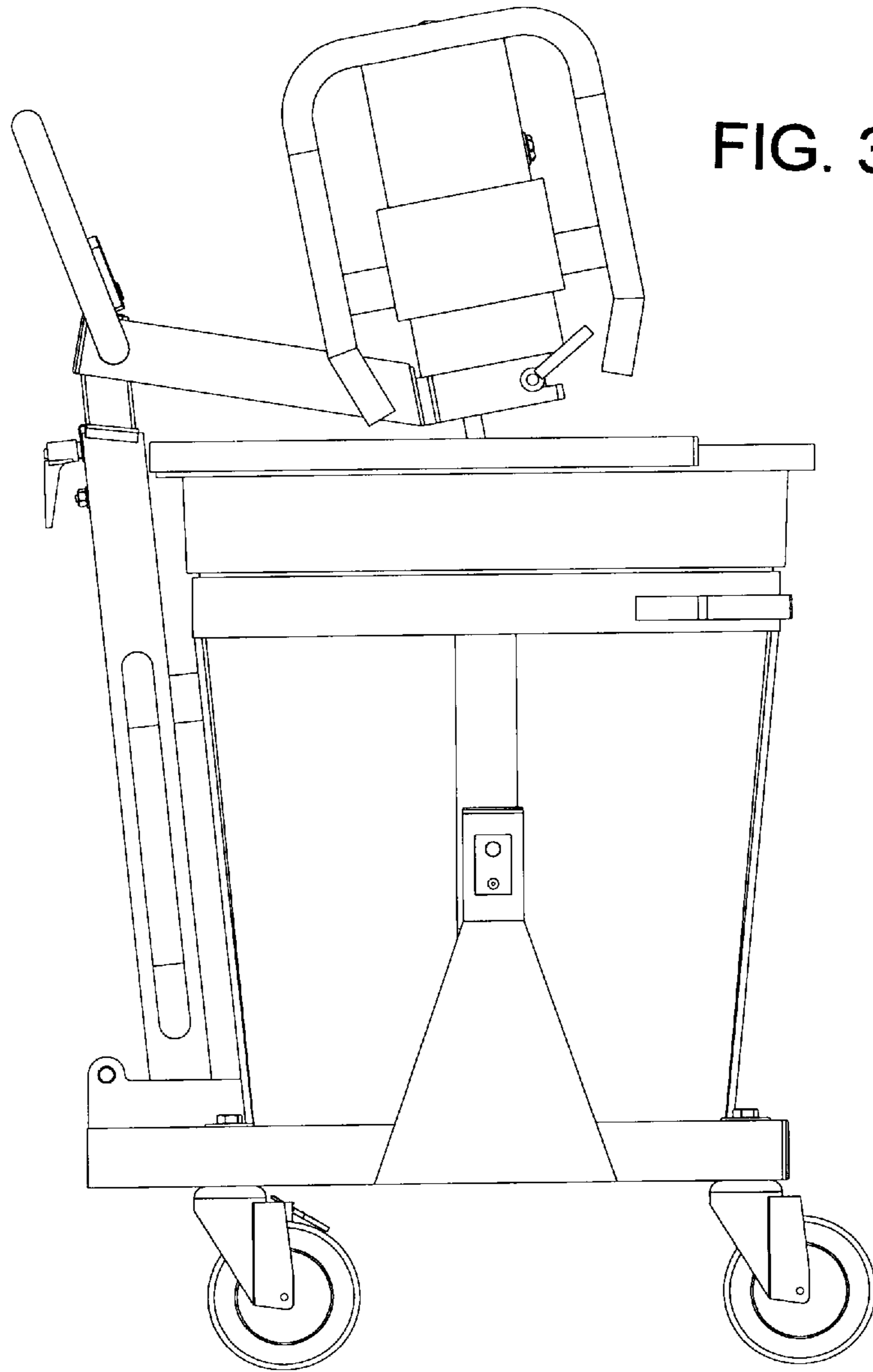
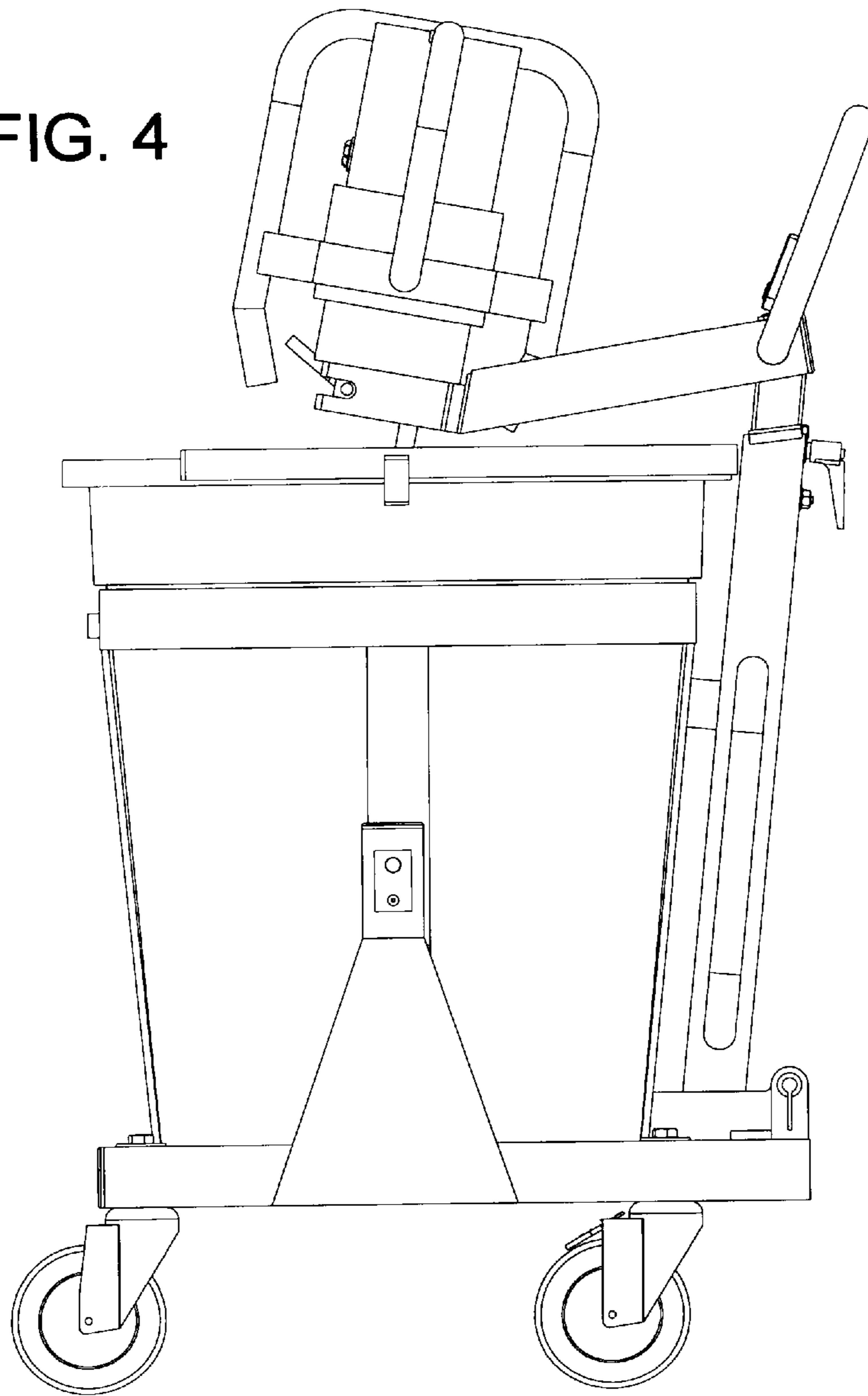

FIG. 4



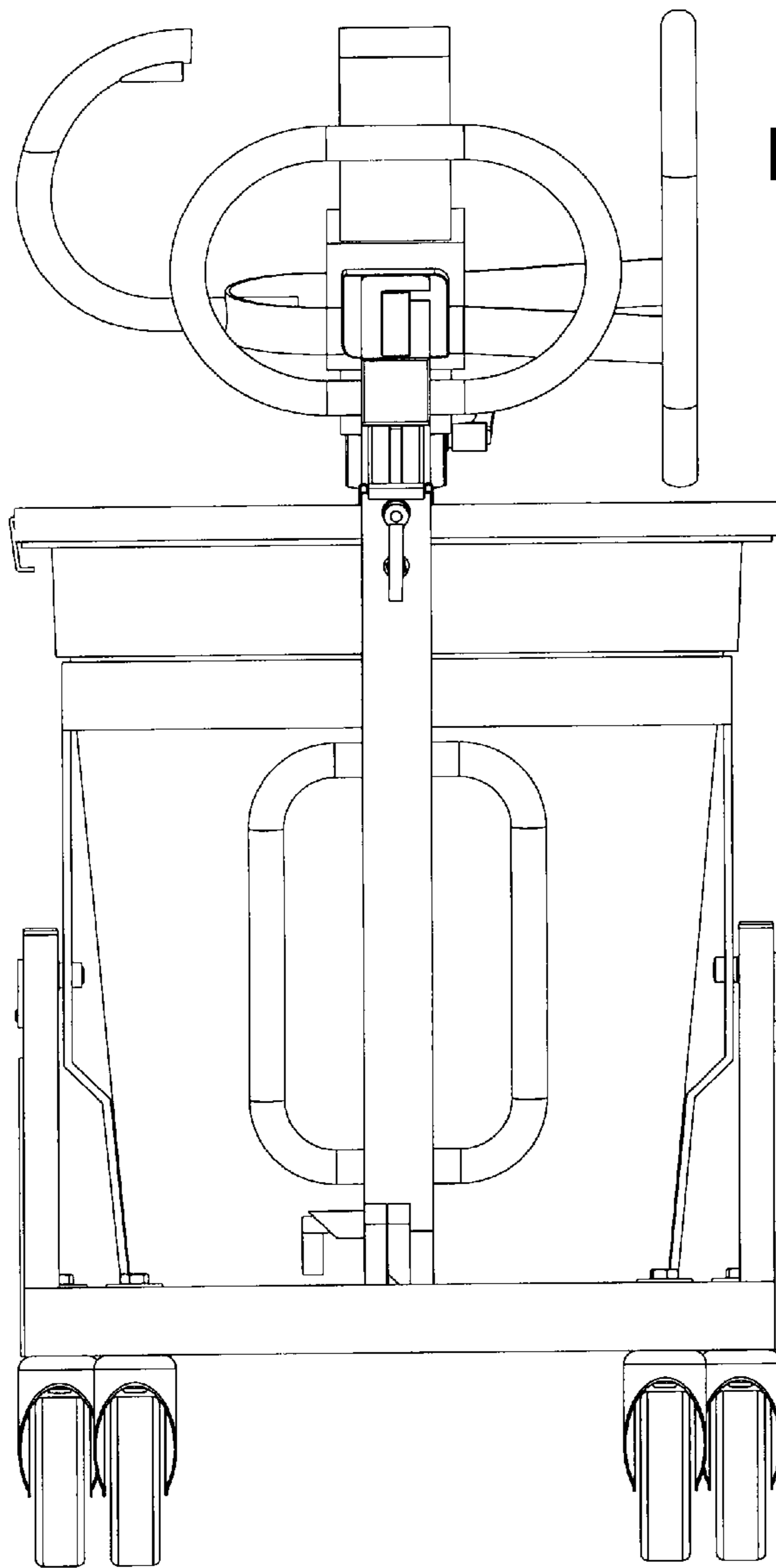

FIG. 5

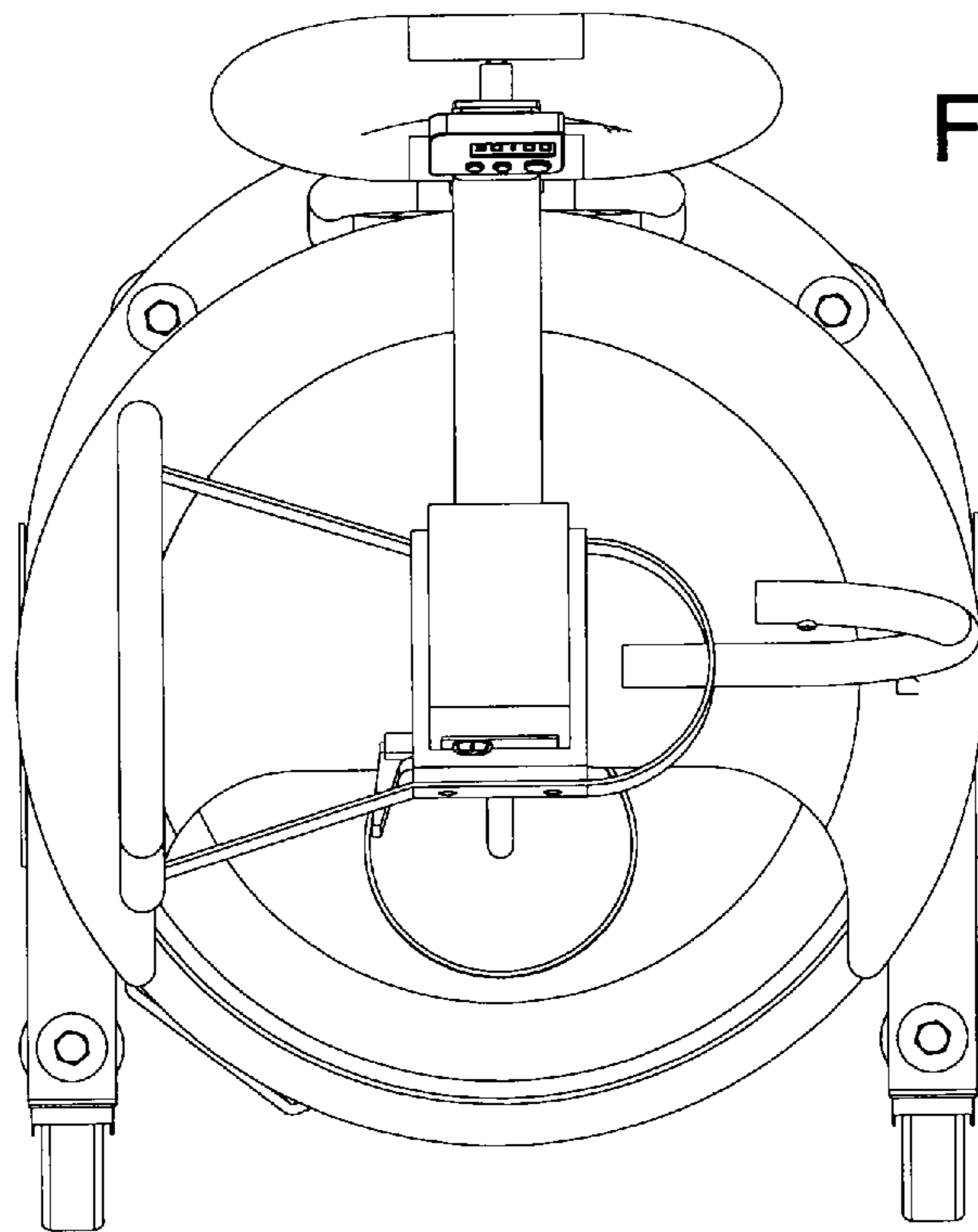

FIG. 6

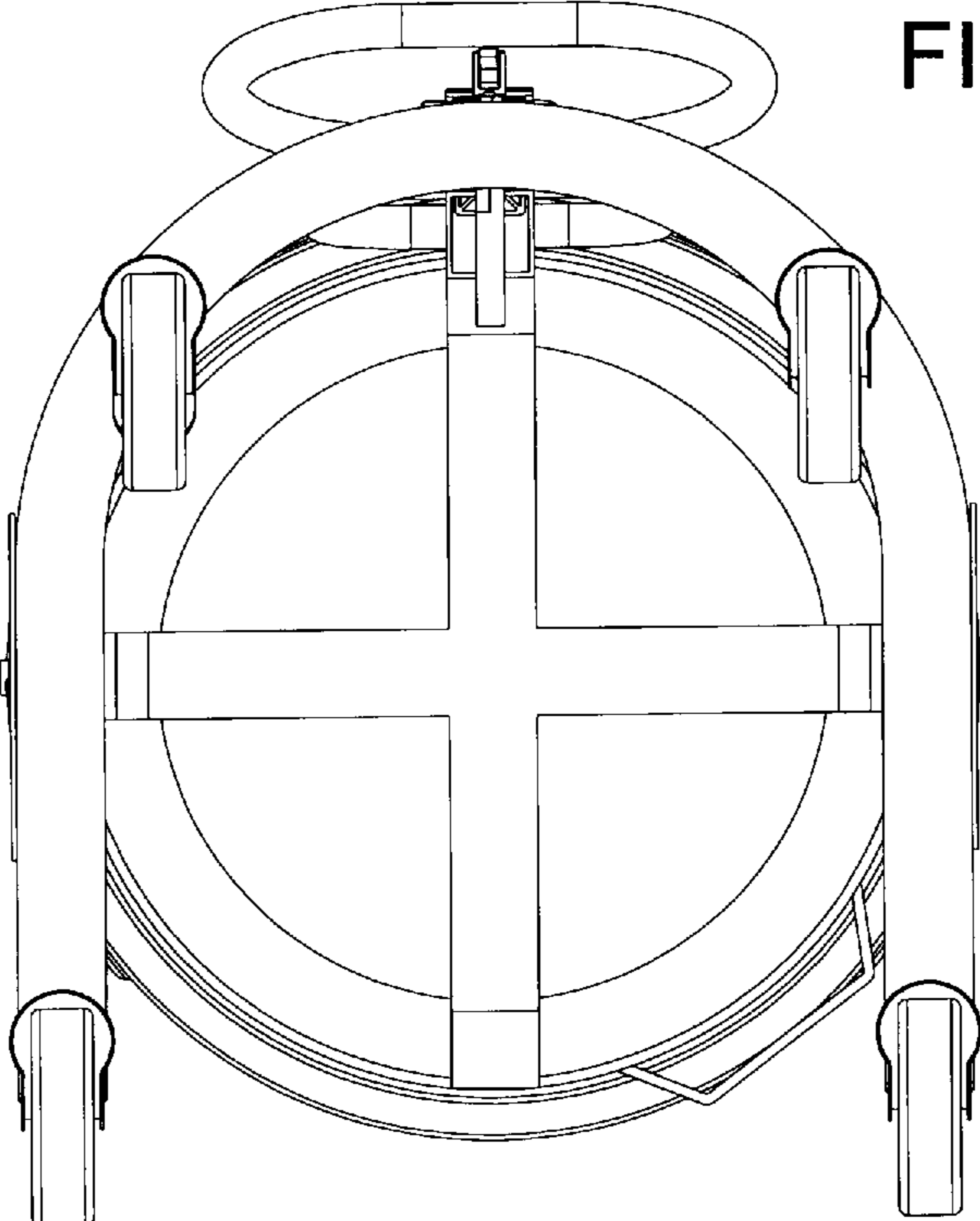

FIG. 7