

US00D668519S

(12) **United States Design Patent**
Berlencourt

(10) **Patent No.:** **US D668,519 S**

(45) **Date of Patent:** **** Oct. 9, 2012**

(54) **VEHICLE ENGINE DRAINING TOOL**

(56) **References Cited**

(75) **Inventor:** **Jean Phillippe Berlencourt**, Châtillon (FR)

(73) **Assignee:** **Stanley Works (Europe) GmbH**, Duebendorf (CH)

(**) **Term:** **14 Years**

(21) **Appl. No.:** **29/409,194**

(22) **Filed:** **Dec. 21, 2011**

(30) **Foreign Application Priority Data**

Jul. 1, 2011 (EM) 001283691

(51) **LOC (9) Cl.** **08-05**

(52) **U.S. Cl.** **D8/21; D8/28**

(58) **Field of Classification Search** D8/21-29;
81/60, 177.1, 177.85, 121.1, 124.3, 165-170,
81/110.1, 176.2, 124.6, 176.1, 176.15, 177.2;
16/110.1; D15/144.1; 219/75, 227, 229,
219/121.16, 121.18

See application file for complete search history.

U.S. PATENT DOCUMENTS

D268,473	S	*	4/1983	Rust	D8/17
D287,927	S	*	1/1987	Zankich	D8/17
4,800,933	A	*	1/1989	Moore et al.	141/98
4,862,776	A	*	9/1989	Poling	81/125
4,867,017	A	*	9/1989	Holman	81/121.1
5,199,331	A	*	4/1993	Tsukamoto	81/121.1
5,852,961	A	*	12/1998	Kotowski	81/180.1

* cited by examiner

Primary Examiner — Raphael Barkai

Assistant Examiner — Randall H Gholson

(74) *Attorney, Agent, or Firm* — Michael P. Leary

(57) **CLAIM**

The ornamental design for a vehicle engine draining tool, as shown and described.

DESCRIPTION

FIG. 1 is a perspective view of a vehicle engine draining tool according to the present invention; FIG. 2 is a front view thereof; FIG. 3 is a rear view thereof; FIG. 4 is a left side view thereof; FIG. 5 is a right side view thereof; FIG. 6 is a top view thereof; and, FIG. 7 is a bottom view thereof.

1 Claim, 4 Drawing Sheets

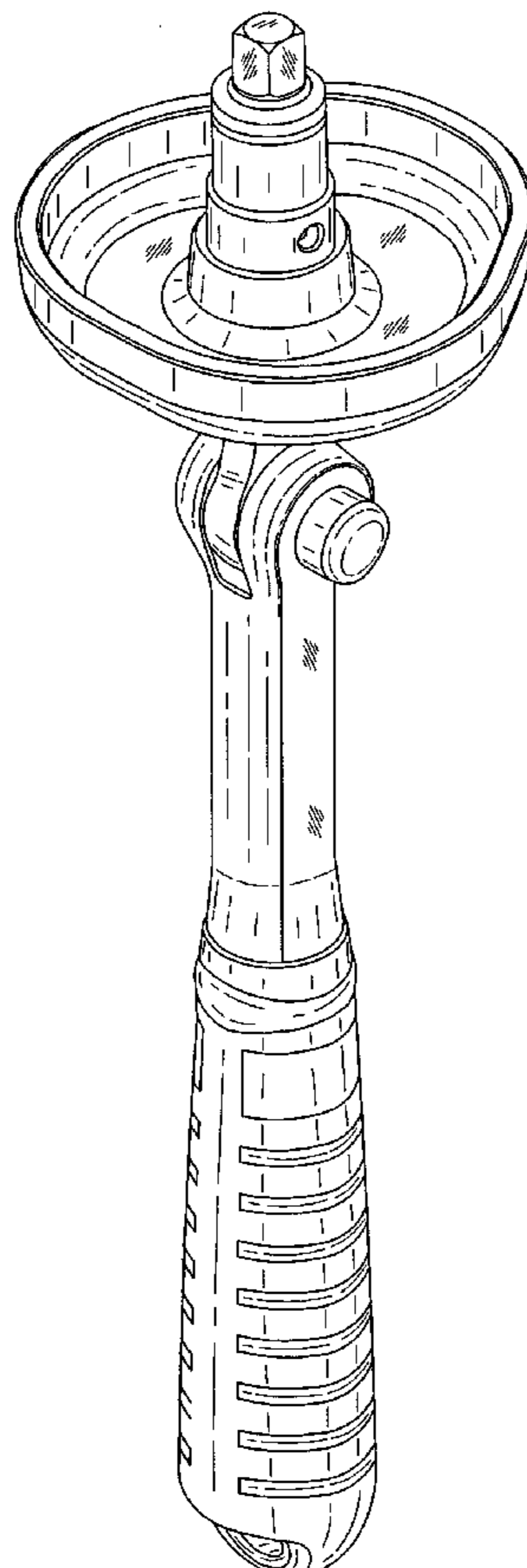

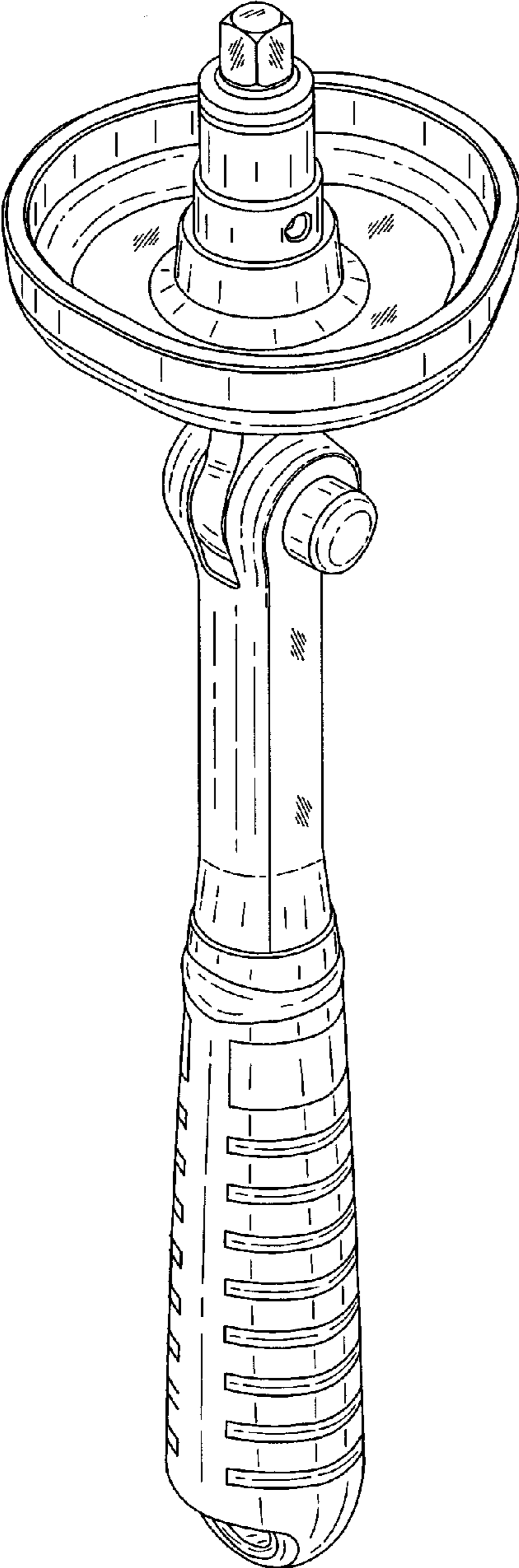

FIG.1

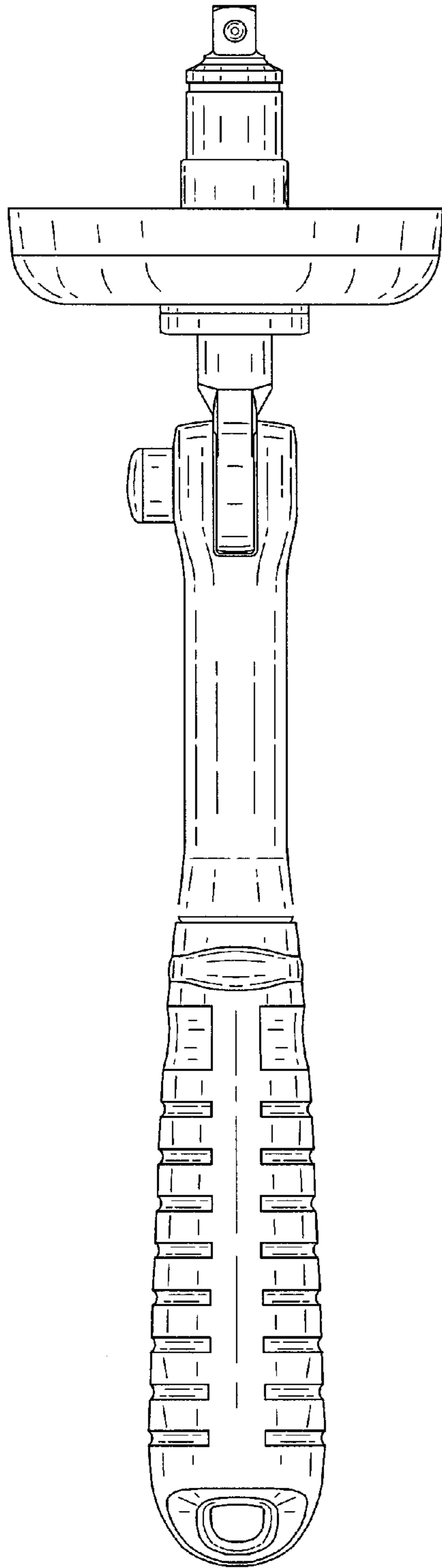

FIG. 2

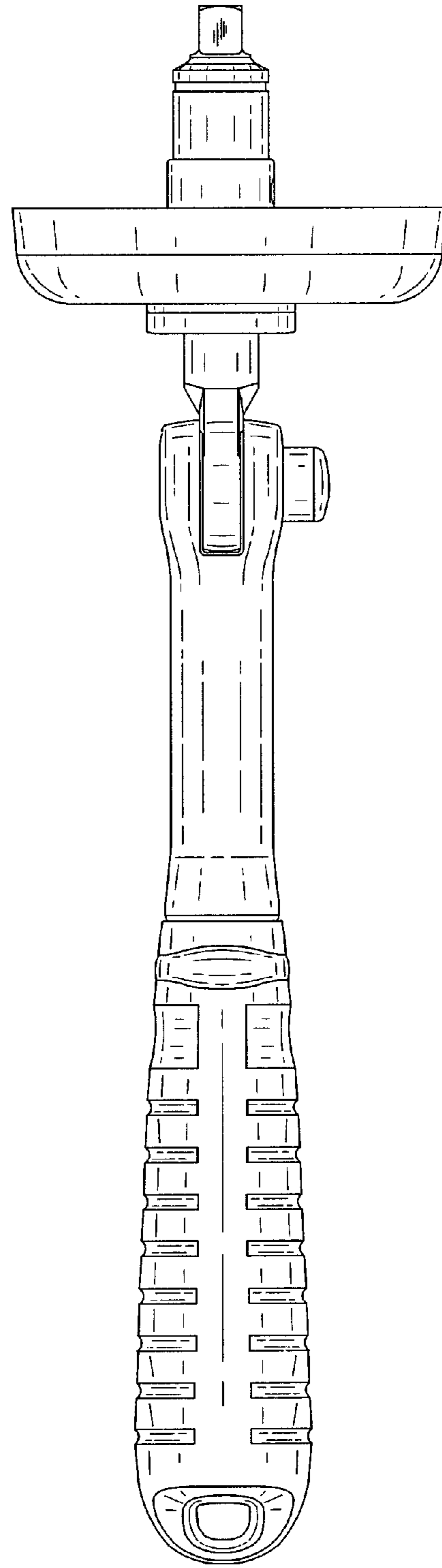

FIG. 3

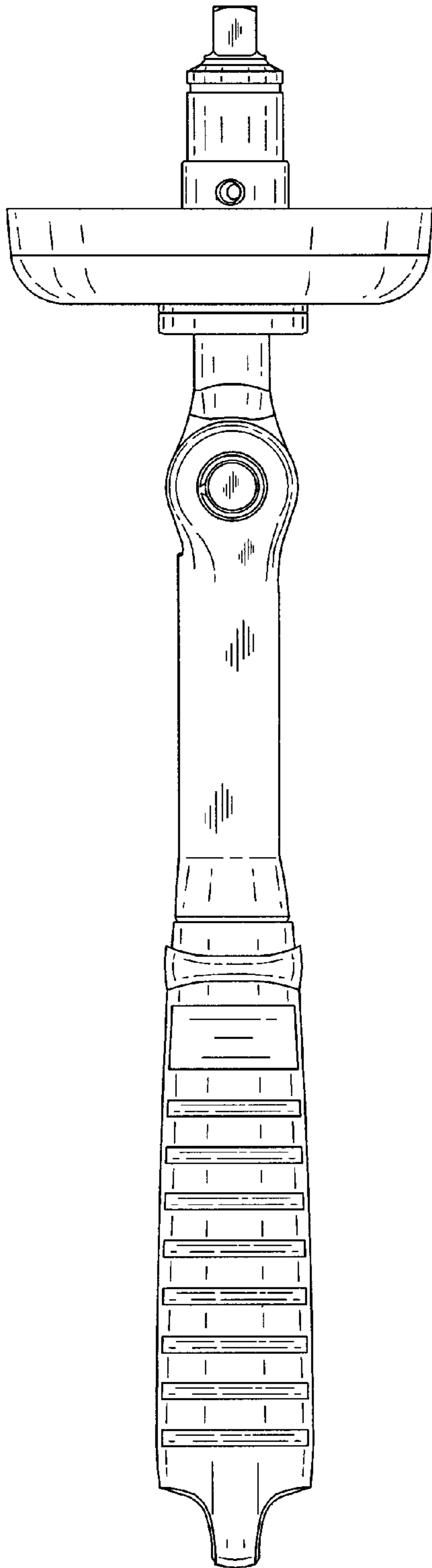

FIG. 4

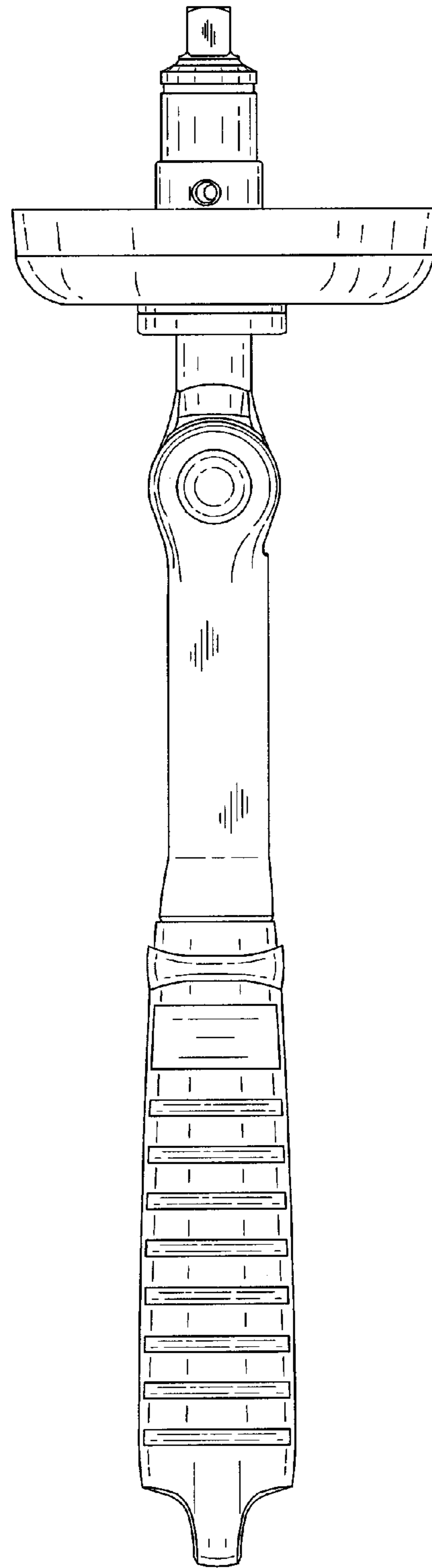

FIG. 5

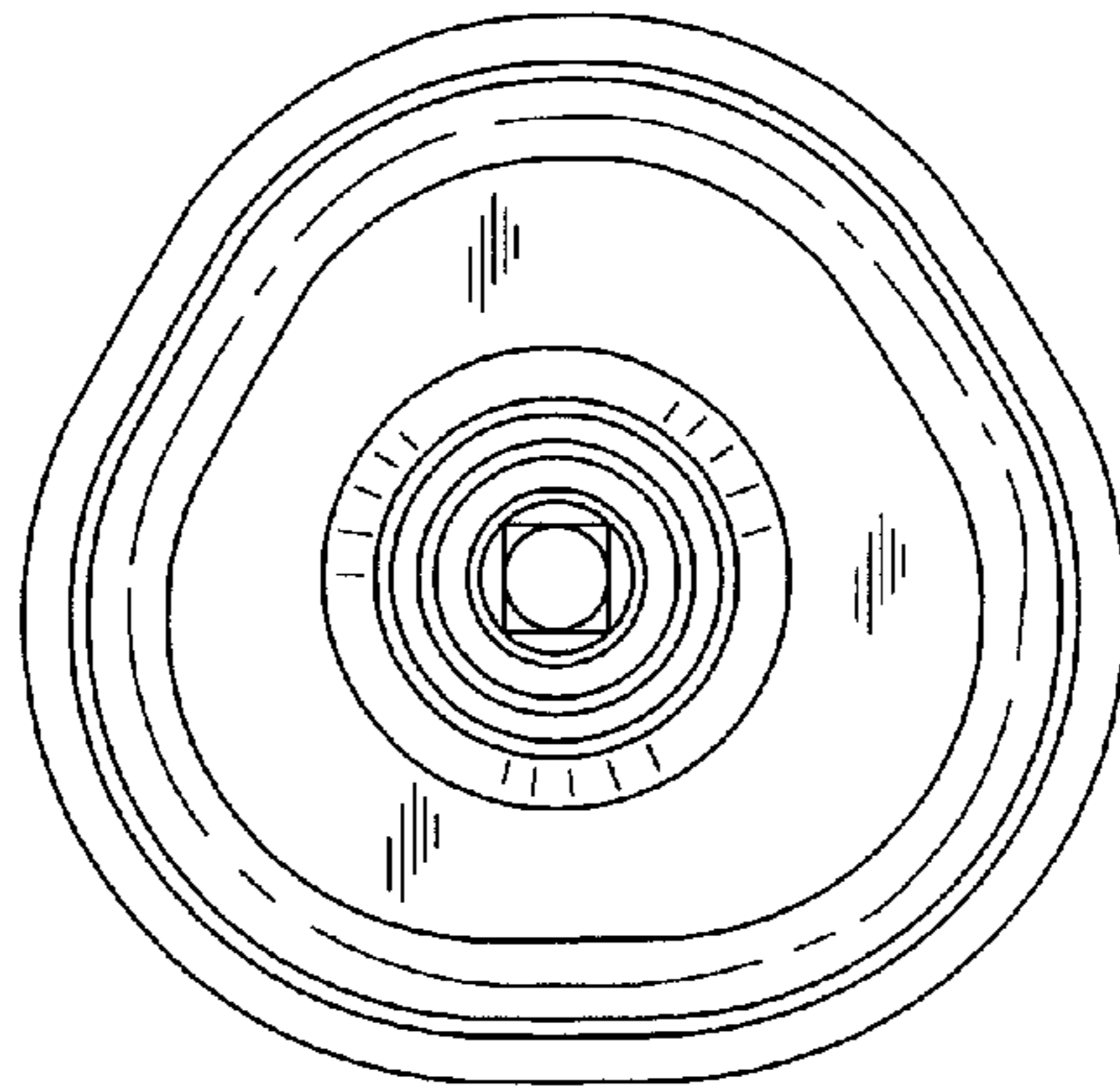

FIG.6

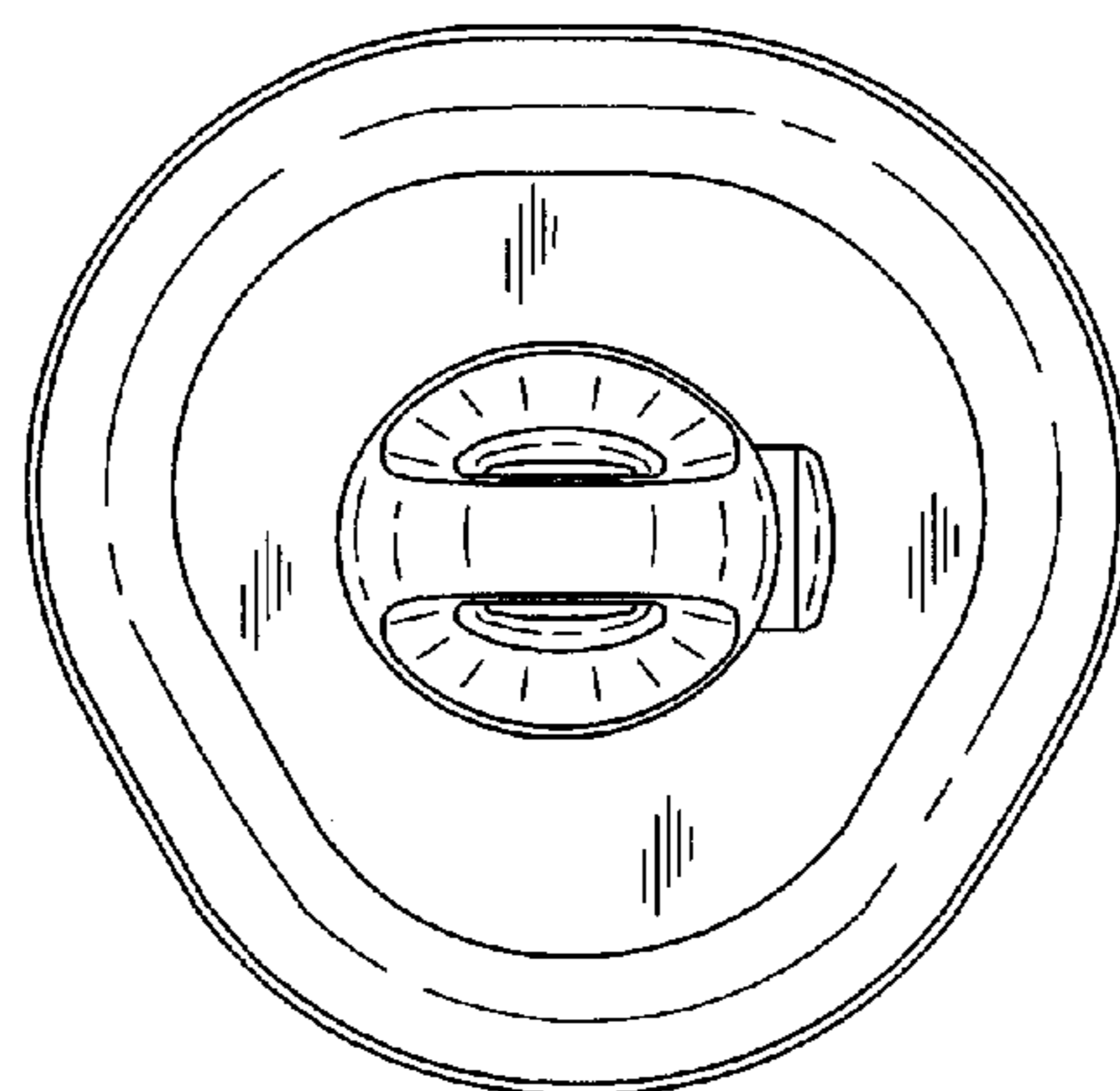

FIG.7