



US00D668210S

(12) **United States Design Patent**  
**Sato**

(10) **Patent No.:** **US D668,210 S**  
(45) **Date of Patent:** **\*\* Oct. 2, 2012**

(54) **AUTOMOBILE TIRE**

(75) Inventor: **Kenichi Sato**, Tokyo (JP)

(73) Assignee: **The Yokohama Rubber Co., Ltd.** (JP)

(\*\*) Term: **14 Years**

(21) Appl. No.: **29/395,876**

(22) Filed: **Apr. 16, 2012**

(30) **Foreign Application Priority Data**

Oct. 18, 2011 (JP) ..... 2011-023900

(51) **LOC (9) Cl.** ..... **12-15**

(52) **U.S. Cl.** ..... **D12/605**

(58) **Field of Classification Search** ..... D12/500-501,  
D12/544, 579, 600-605; 152/523-524, DIG. 12,  
152/555; D7/588, 396.4-396.5  
See application file for complete search history.

(56) **References Cited**

**U.S. PATENT DOCUMENTS**

D452,203 S *	12/2001	Kajikawa	.....	D12/605
D477,810 S *	7/2003	Budich et al.	.....	D12/605
D555,583 S *	11/2007	Itoi	.....	D12/605
D569,336 S *	5/2008	Onoe	.....	D12/605
D569,337 S *	5/2008	Iwabuchi	.....	D12/605
D569,792 S *	5/2008	Holden et al.	.....	D12/605
D584,222 S *	1/2009	Ohashi	.....	D12/605
D593,486 S *	6/2009	Yonetsu	.....	D12/605
D596,119 S *	7/2009	Fujita	.....	D12/605
D597,025 S *	7/2009	Fujita	.....	D12/605
D606,013 S *	12/2009	Reese et al.	.....	D12/605
D626,502 S *	11/2010	Nakamura	.....	D12/605
D632,641 S *	2/2011	Sato	.....	D12/605
D647,044 S *	10/2011	Takemoto	.....	D12/605
D647,473 S *	10/2011	Kujime	.....	D12/605
D647,474 S *	10/2011	Takahashi	.....	D12/605
D655,671 S *	3/2012	Yasunaga	.....	D12/605

**FOREIGN PATENT DOCUMENTS**

JP	1112444	6/2001
JP	1147505	7/2002
JP	1154783	9/2002

JP	1222114	11/2004
JP	1240124	5/2005
JP	1240412	5/2005
JP	1257246	12/2005
JP	1269489	4/2006
JP	1269621	4/2006
JP	1313154	10/2007
JP	1331056	5/2008
JP	1331537	6/2008
JP	1333649	6/2008
JP	1336175	7/2008
JP	1347759	1/2009

(Continued)

*Primary Examiner* — Stacia Cadmus

(74) *Attorney, Agent, or Firm* — SAIDMAN DesignLaw Group

(57) **CLAIM**

The ornamental design for an automobile tire, as shown and described.

**DESCRIPTION**

FIG. 1 is a perspective view of the front, top and left side of an automobile tire showing my new design;  
 FIG. 2 is a front view thereof;  
 FIG. 3 is a rear view thereof;  
 FIG. 4 is a left side view thereof;  
 FIG. 5 is a right side view thereof;  
 FIG. 6 is a top view thereof;  
 FIG. 7 is a bottom view thereof;  
 FIG. 8 is an enlarged, fragmentary front view of the area circumscribed by box 8 of FIG. 2;  
 FIG. 9 is an enlarged, cross-sectional view thereof, taken along line 9-9 of FIG. 8; and,  
 FIG. 10 is an enlarged, fragmentary view of the area circumscribed by box 10 of FIG. 1.  
 The broken lines represent environmental structure only and form no part of the claimed design.

**1 Claim, 7 Drawing Sheets**

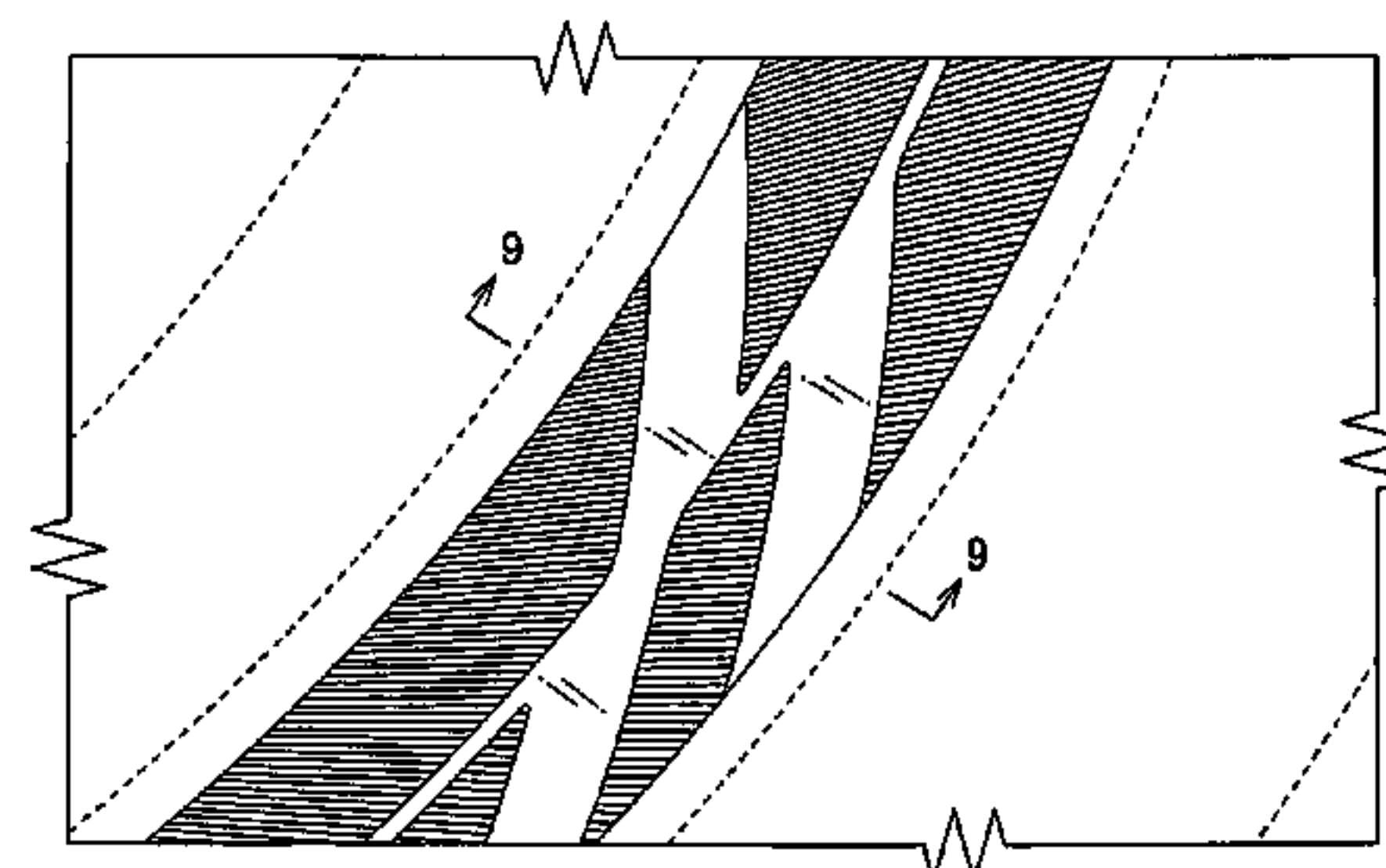
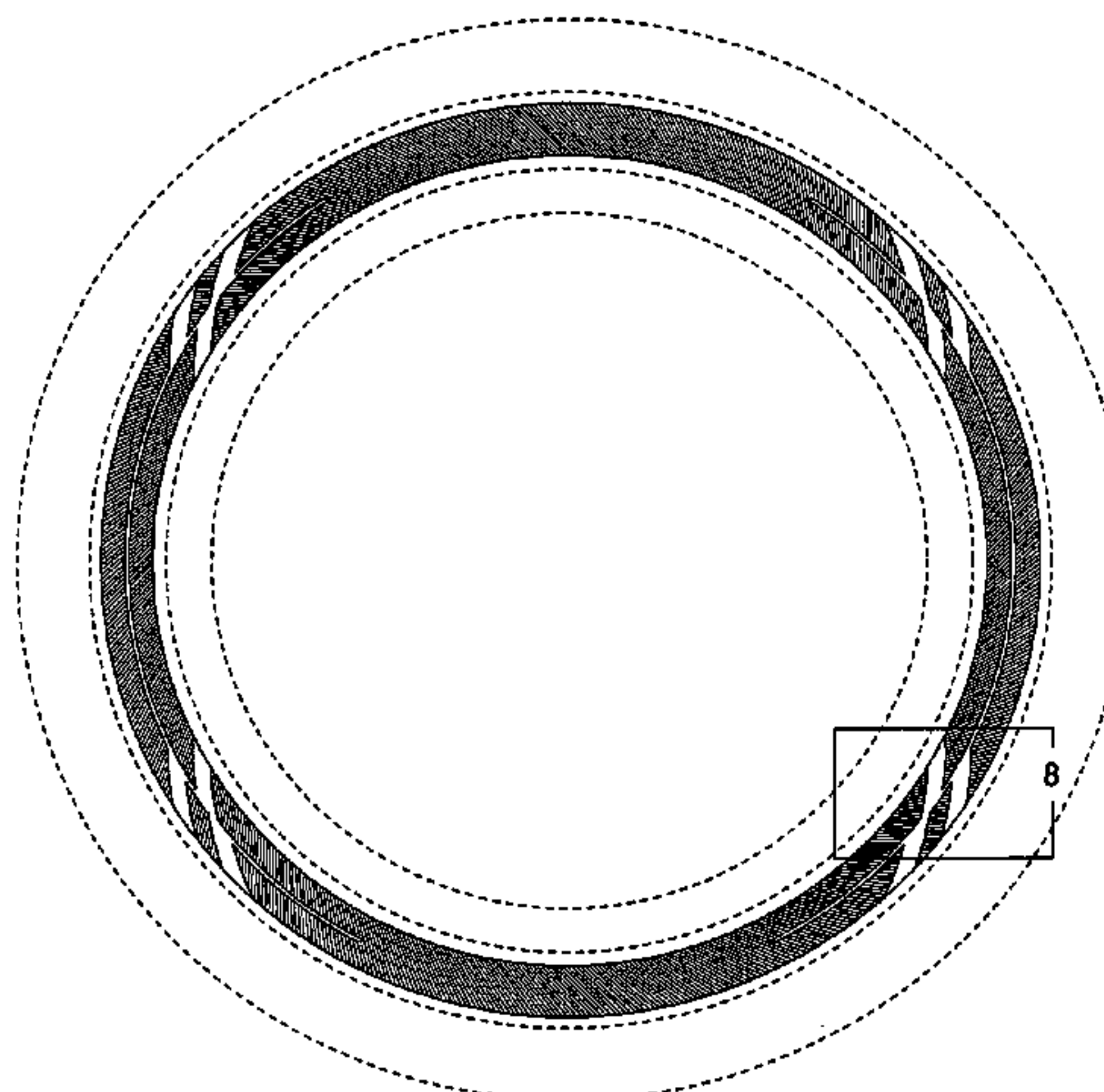

# US D668,210 S

Page 2

---

FOREIGN PATENT DOCUMENTS			JP	1372078	10/2009
JP	1348146	1/2009	JP	1401939	11/2010
JP	1370815	10/2009			
JP	1372077	10/2009			

\* cited by examiner

Fig. 1

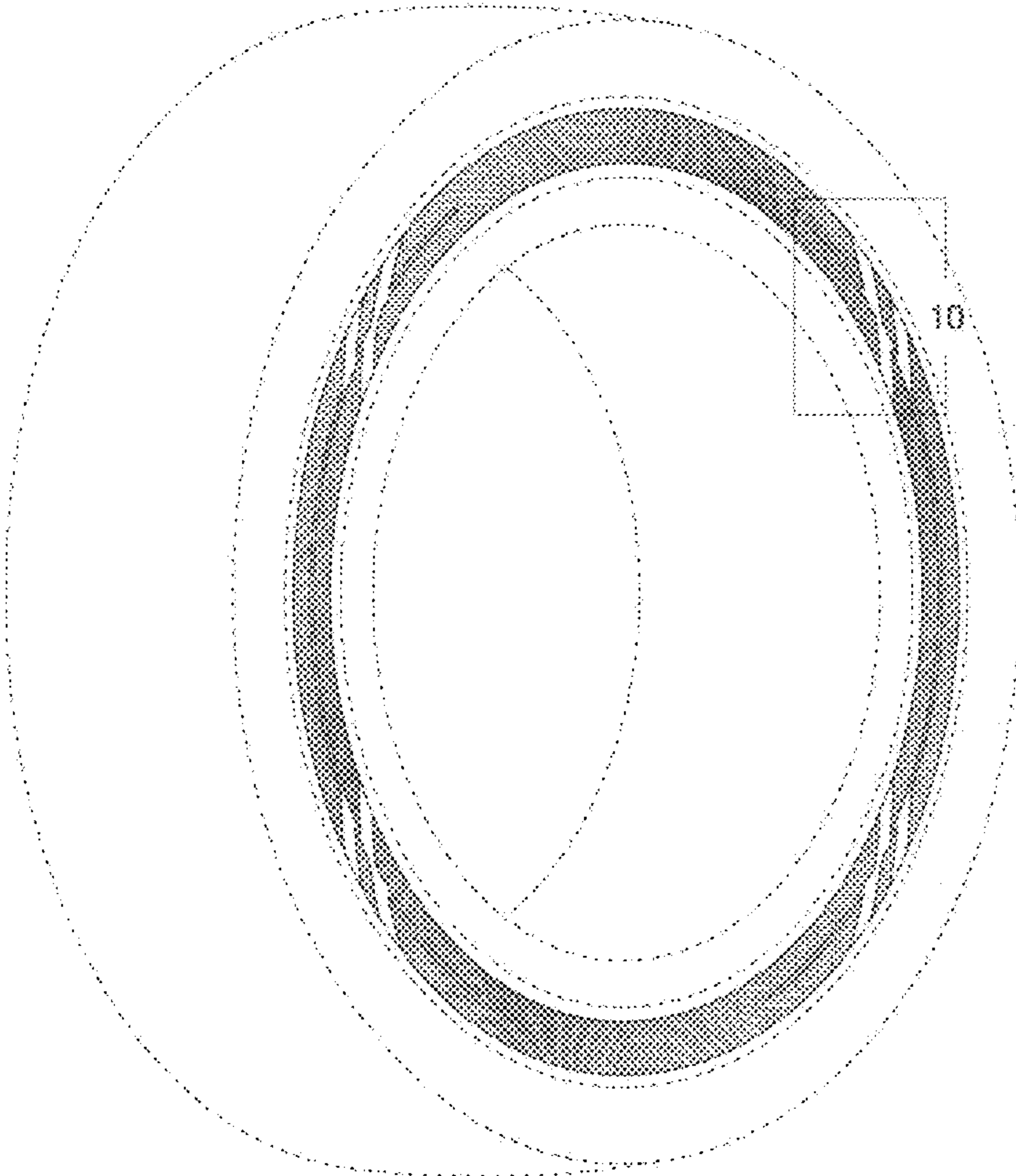

Fig. 2

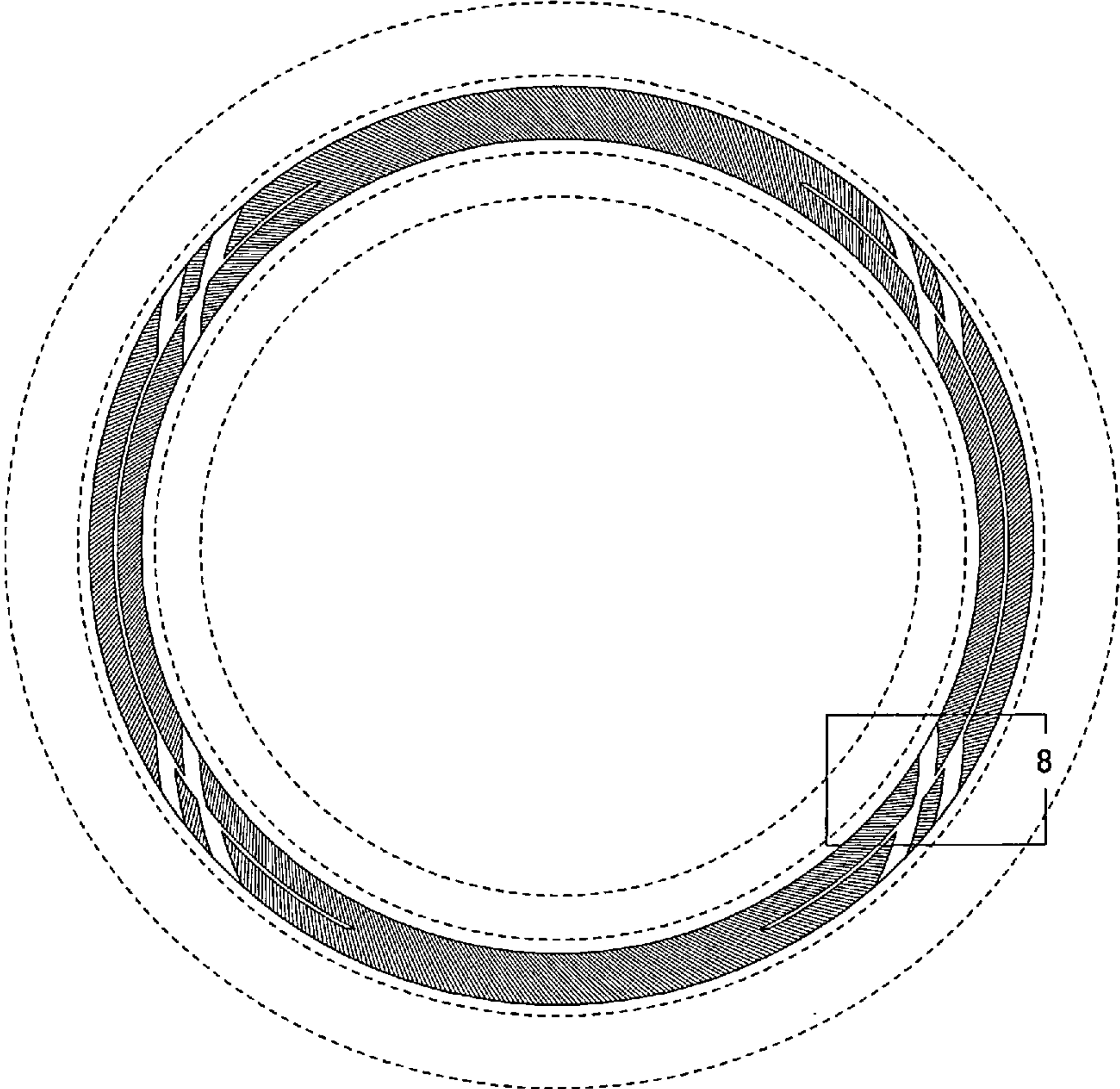

Fig. 3

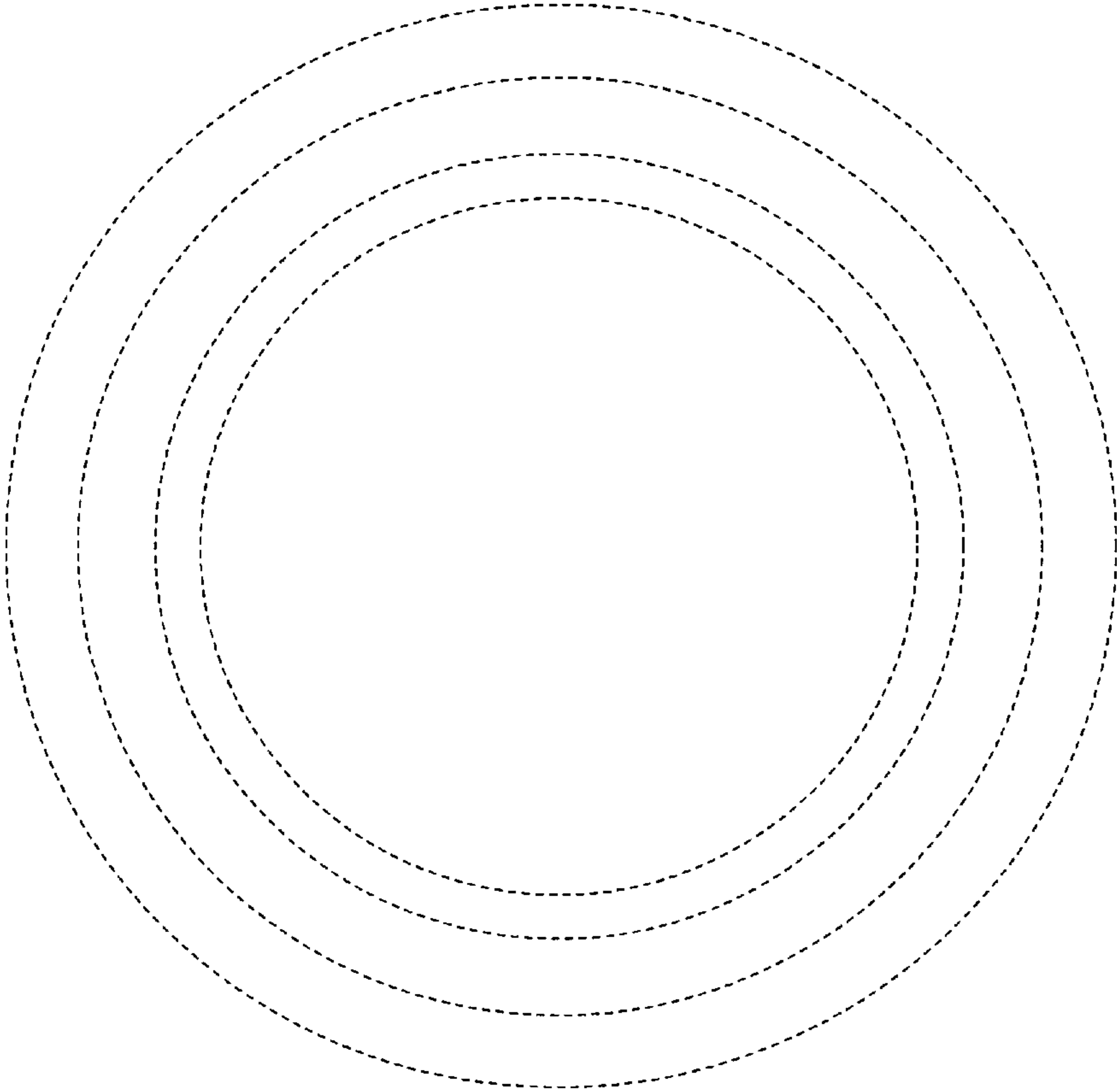



Fig. 4

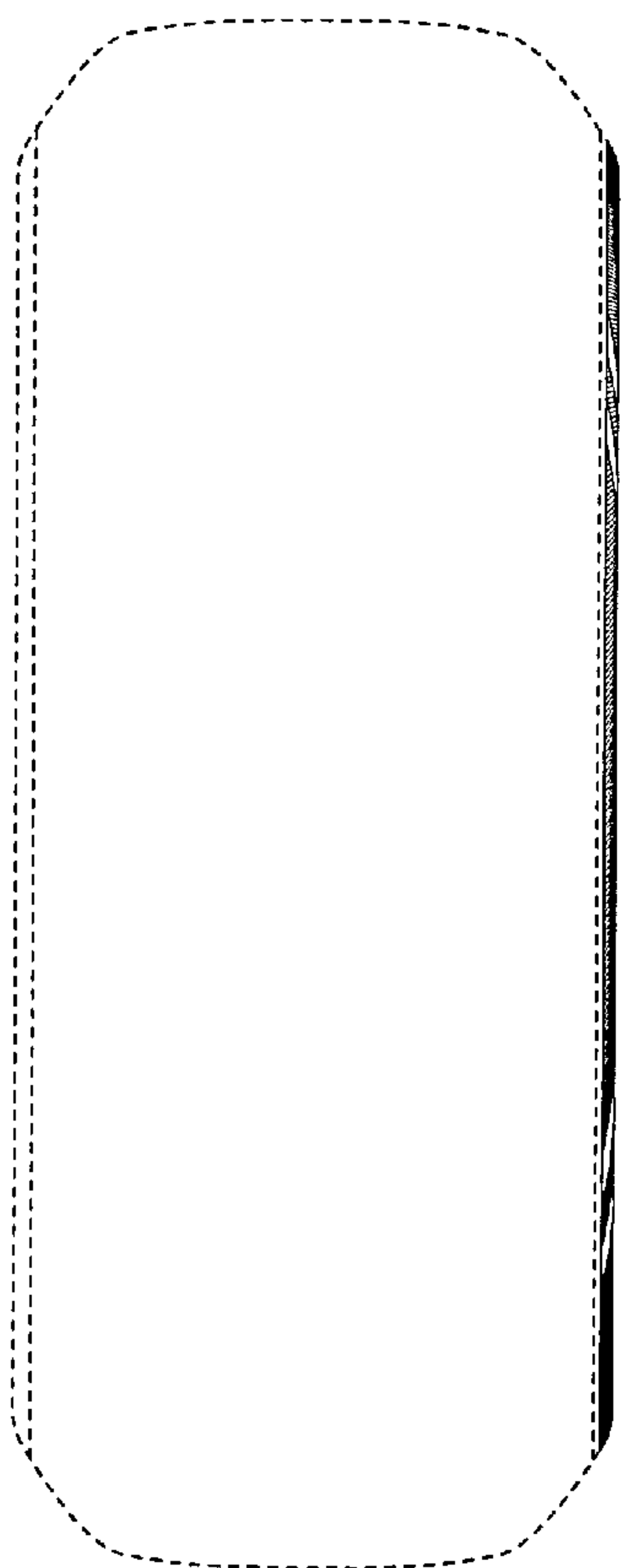

Fig. 5

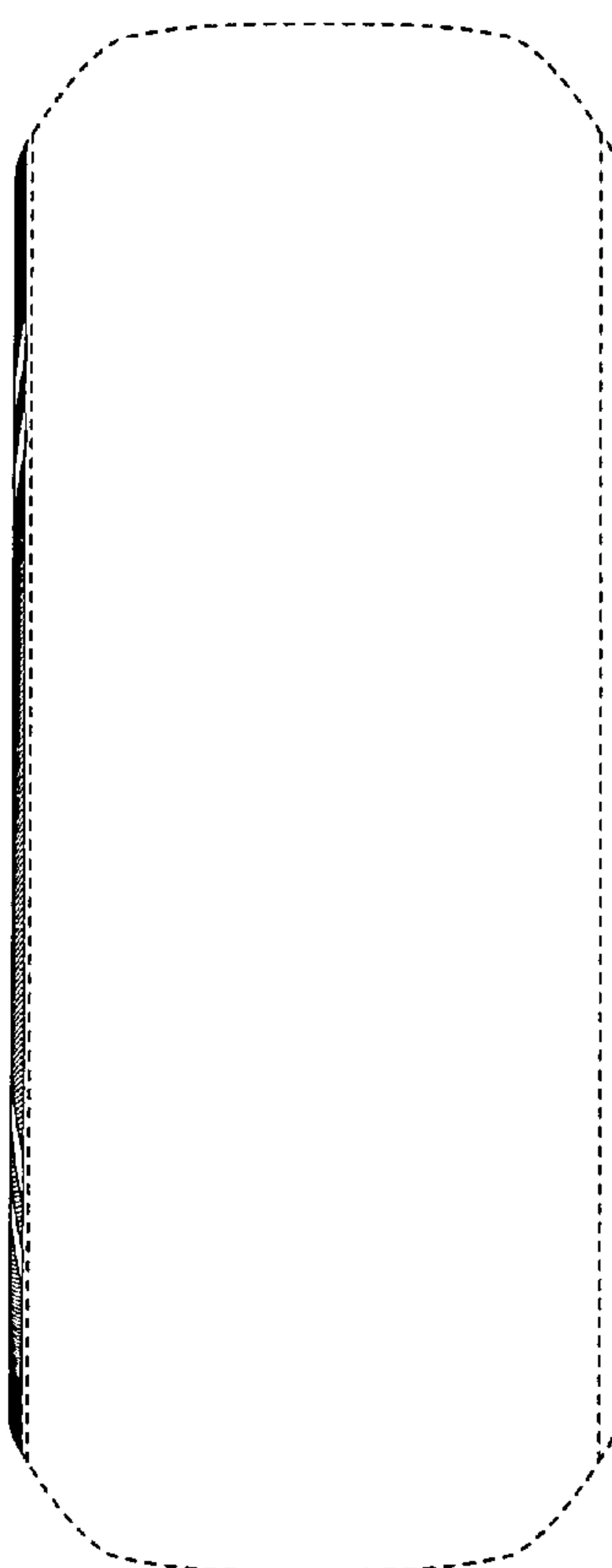

Fig. 6

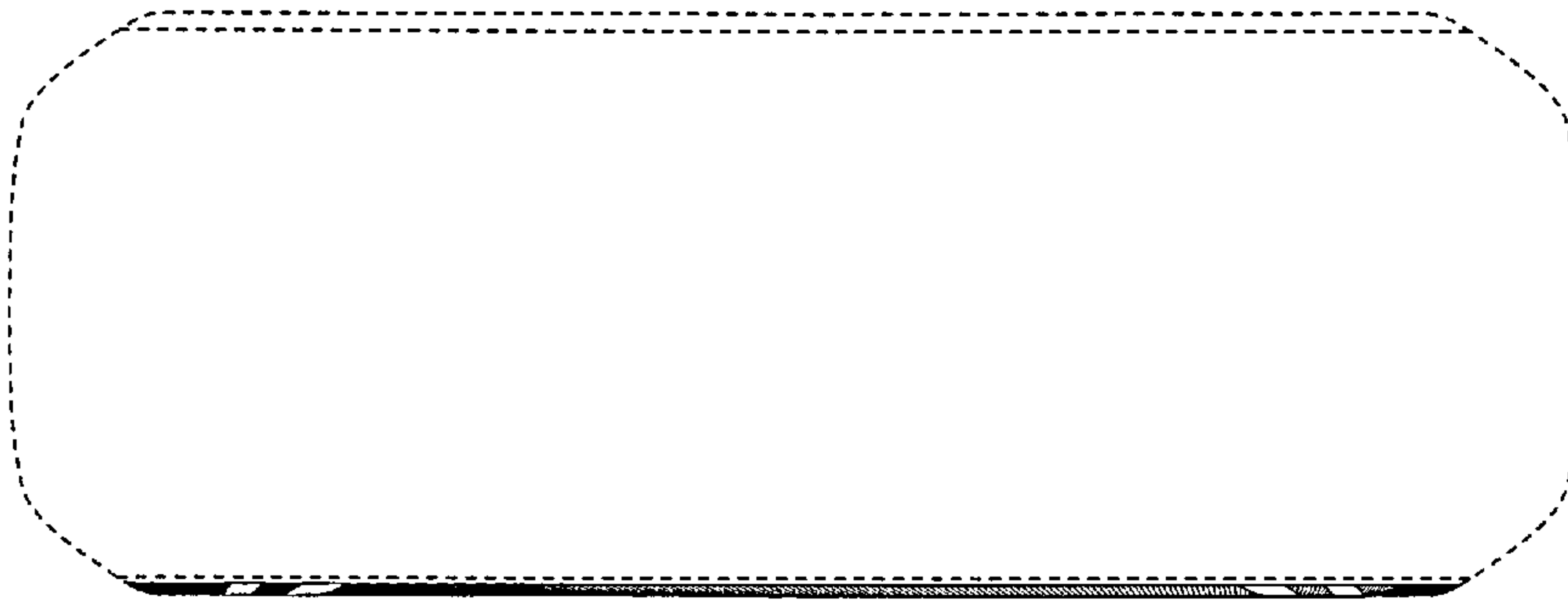

Fig. 7

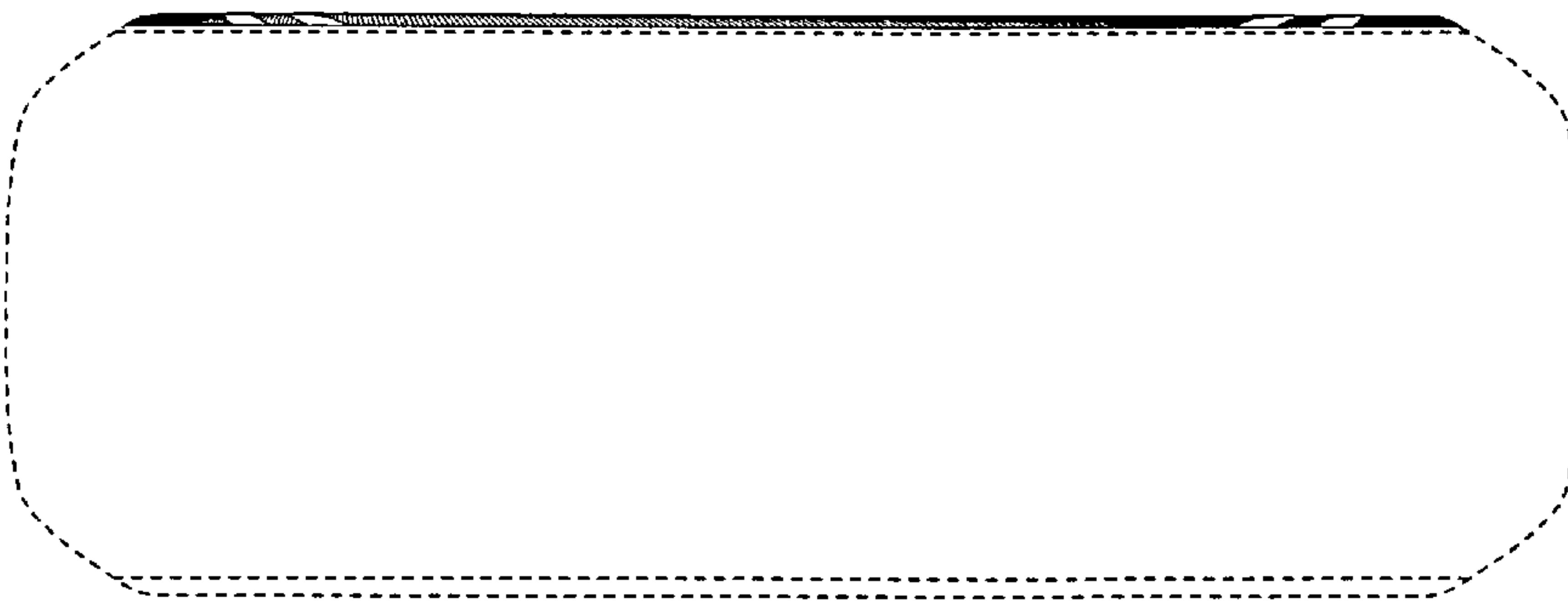

Fig. 8

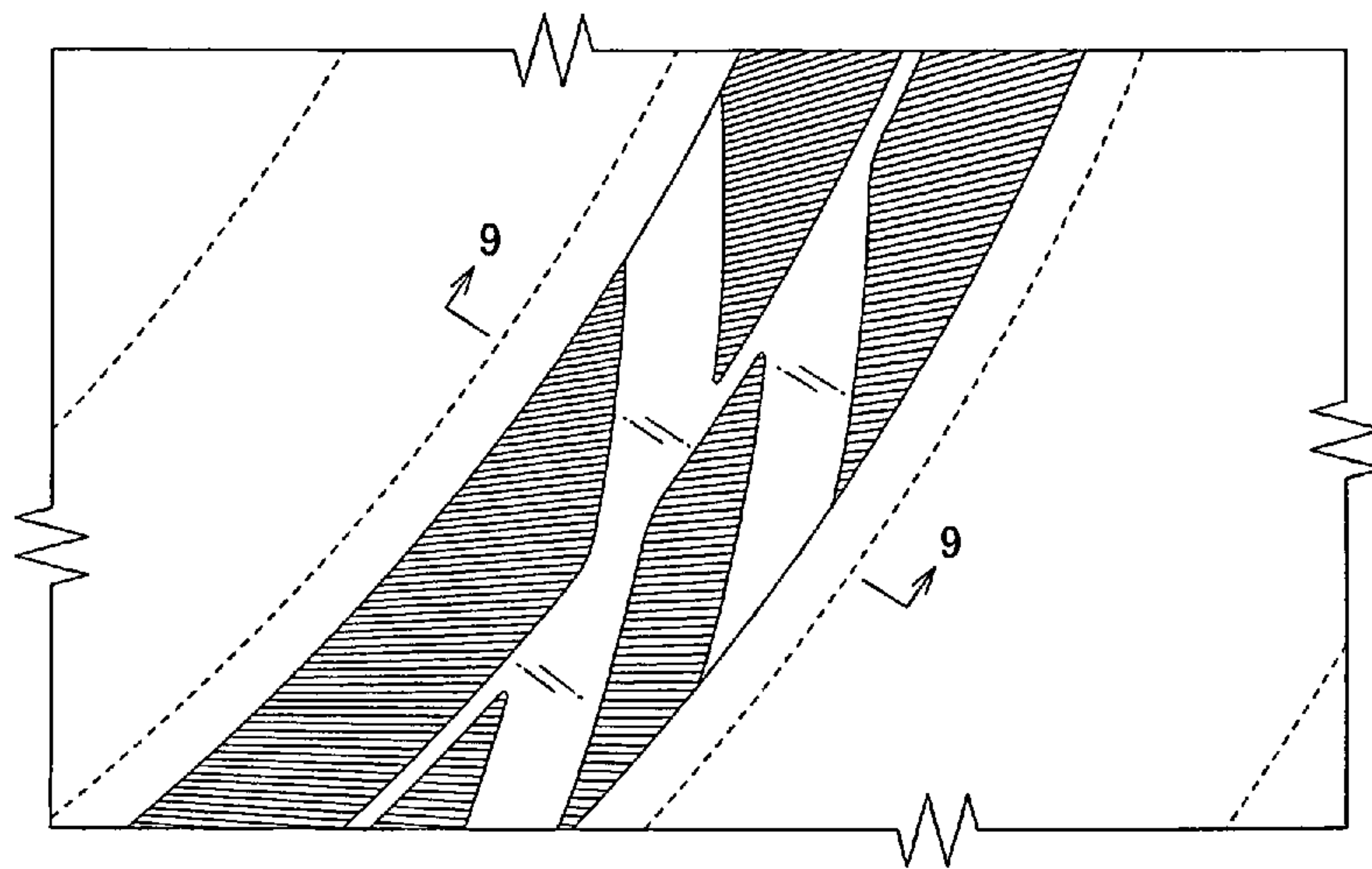

Fig. 9





Fig. 10

