



US00D668182S

(12) **United States Design Patent**
Barba Franco et al.

(10) **Patent No.:** **US D668,182 S**
(45) **Date of Patent:** **** Oct. 2, 2012**

(54) **VEHICLE BODY**

D628,939 S * 12/2010 Komuro D12/92
D644,567 S 9/2011 Kozub
D646,205 S * 10/2011 Bittner et al. D12/92

(75) Inventors: **Carlos M. Barba Franco**, Sao Paulo (BR); **John H. Ware**, Sao Paulo (BR); **Wagner M. Dias**, Santo Andre (BR); **Lamildson Rolin**, Sao Caetano Do Sul (BR)

(73) Assignee: **GM Global Technology Operations LLC**, Detroit, MI (US)

(**) Term: **14 Years**

(21) Appl. No.: **29/392,615**

(22) Filed: **May 24, 2011**

(51) **LOC (9) Cl.** **12-08**

(52) **U.S. Cl.** **D12/92**

(58) **Field of Classification Search** D12/86,
D12/90-92; D21/424, 433, 434; 296/181.1,
296/181.5

See application file for complete search history.

(56) **References Cited**

U.S. PATENT DOCUMENTS

- D592,105 S 5/2009 Dean et al.
- D597,447 S 8/2009 Folden
- D603,755 S 11/2009 Peters
- D605,082 S 12/2009 Munson
- D605,083 S 12/2009 Manoogian, II et al.
- D608,249 S 1/2010 Peters
- D609,608 S 2/2010 Boniface et al.
- D611,387 S 3/2010 Thompson et al.
- D611,879 S 3/2010 Kim et al.
- D612,297 S 3/2010 Peters et al.
- D615,458 S 5/2010 Thompson et al.
- D623,090 S 9/2010 Cox et al.
- D626,456 S * 11/2010 Miyata et al. D12/92
- D626,457 S * 11/2010 Lian et al. D12/92

OTHER PUBLICATIONS

U.S. Appl. No. 29/407,580, filed Nov. 30, 2011; First Named Inventor: Robert J. Munson; Title: Vehicle Body.
U.S. Appl. No. 29/409,092, filed Dec. 20, 2011; First Named Inventor: Nicholas J. David; Title: Vehicle Body.
U.S. Appl. No. 29/413,221, filed Feb. 13, 2012; First Named Inventor: Joseph C. Baker; Title: Vehicle Body.
U.S. Appl. No. 29/414,260; filed Feb. 27, 2012; First Named Inventor: Steven M. McCabe; Title: Vehicle Body.
U.S. Appl. No. 29/403,440, filed Oct. 6, 2011; First Named Inventor: Niki J. Smart; Title: Vehicle Body.

* cited by examiner

Primary Examiner — Melody N Brown

(74) *Attorney, Agent, or Firm* — Reising Ethington P.C.; Lionel D. Anderson

(57) **CLAIM**

The ornamental design for a vehicle body, as shown and described.

DESCRIPTION

FIG. 1 is a front view of a vehicle body showing the new design;
FIG. 2 is a left front view thereof;
FIG. 3 is a left side view thereof, the right side being a mirror image thereof;
FIG. 4 is a top plan view thereof;
FIG. 5 is a left rear view thereof; and,
FIG. 6 is a rear view thereof.
In the drawing views, the tires and wheels form no part of the claimed invention.

1 Claim, 6 Drawing Sheets

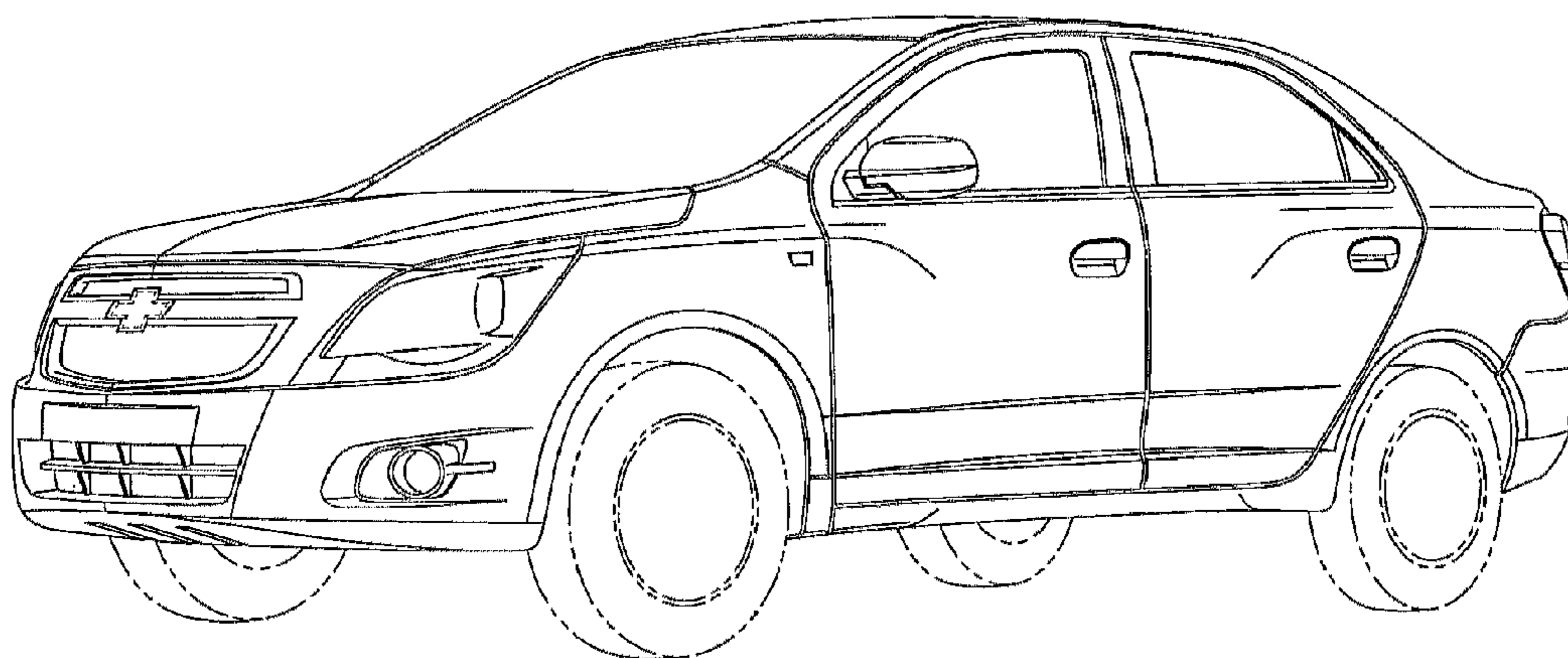

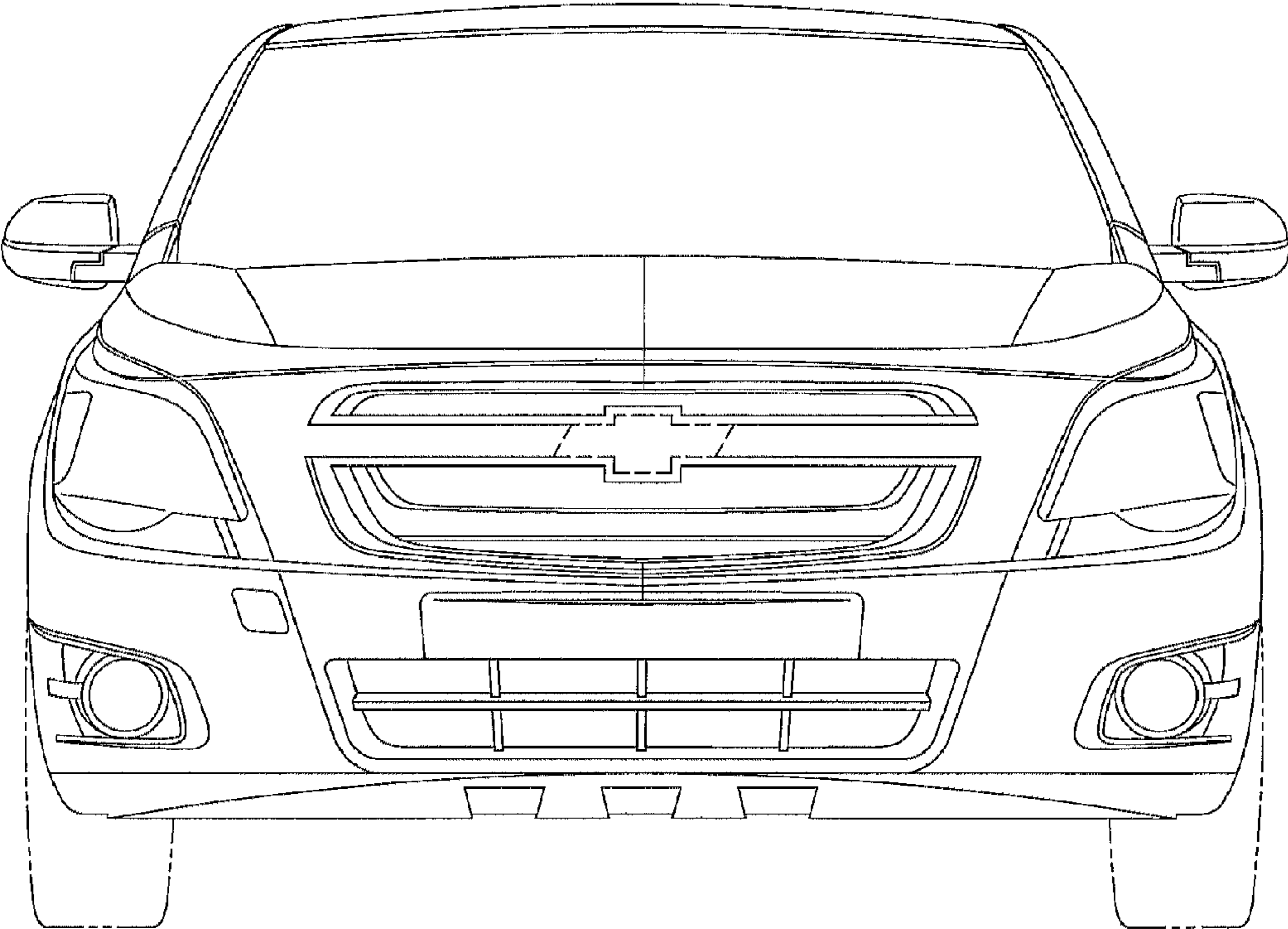

Fig-1

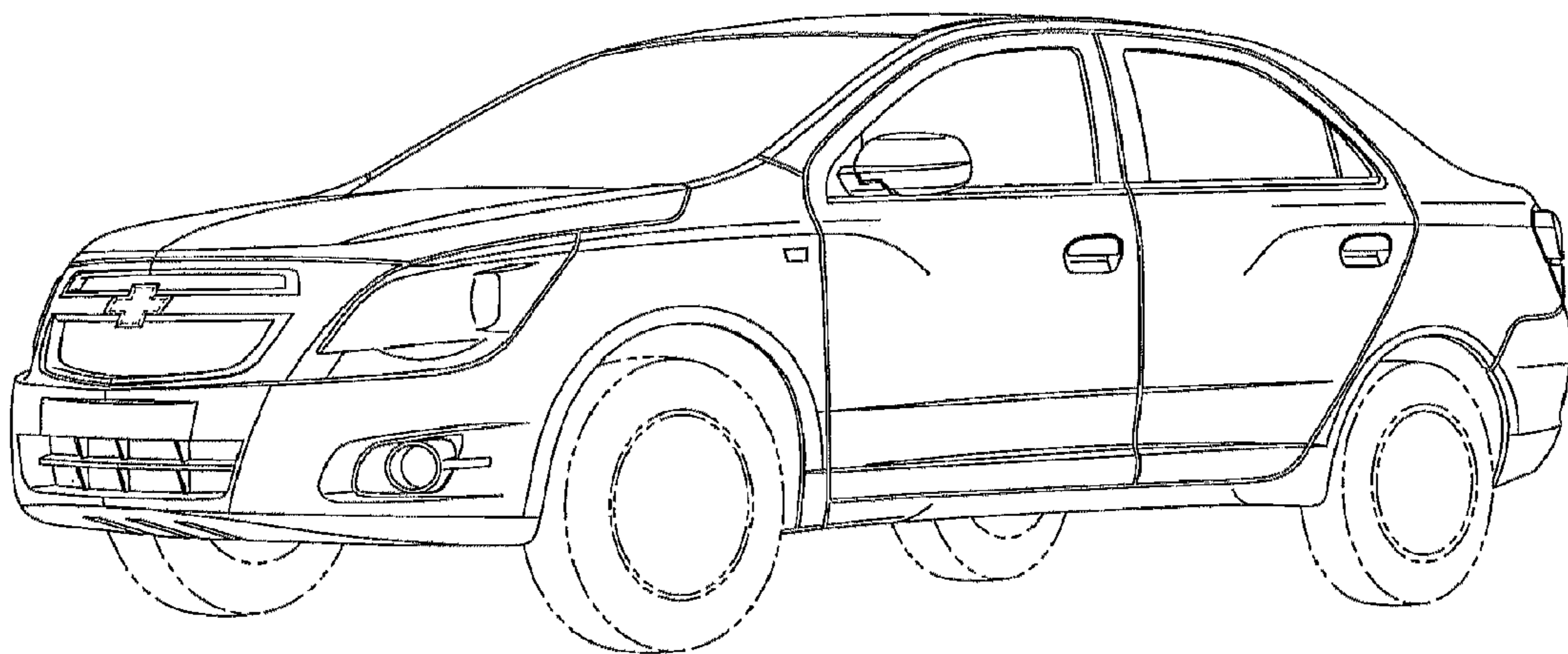

Fig-2

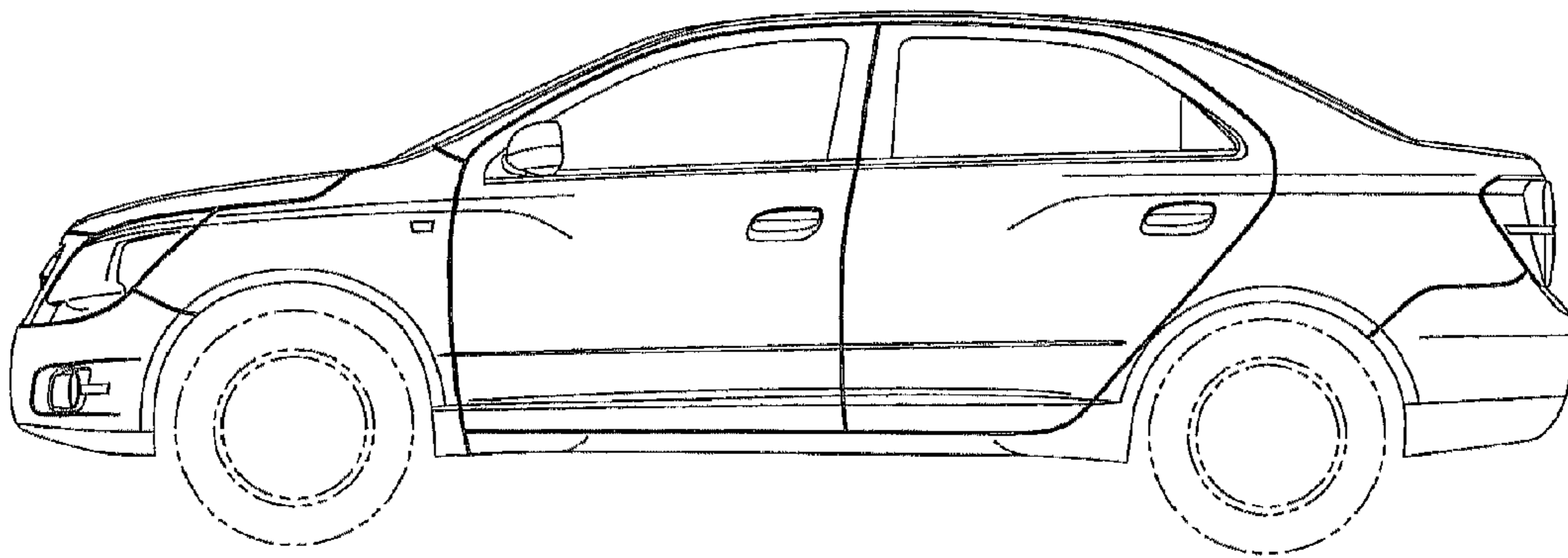

Fig-3

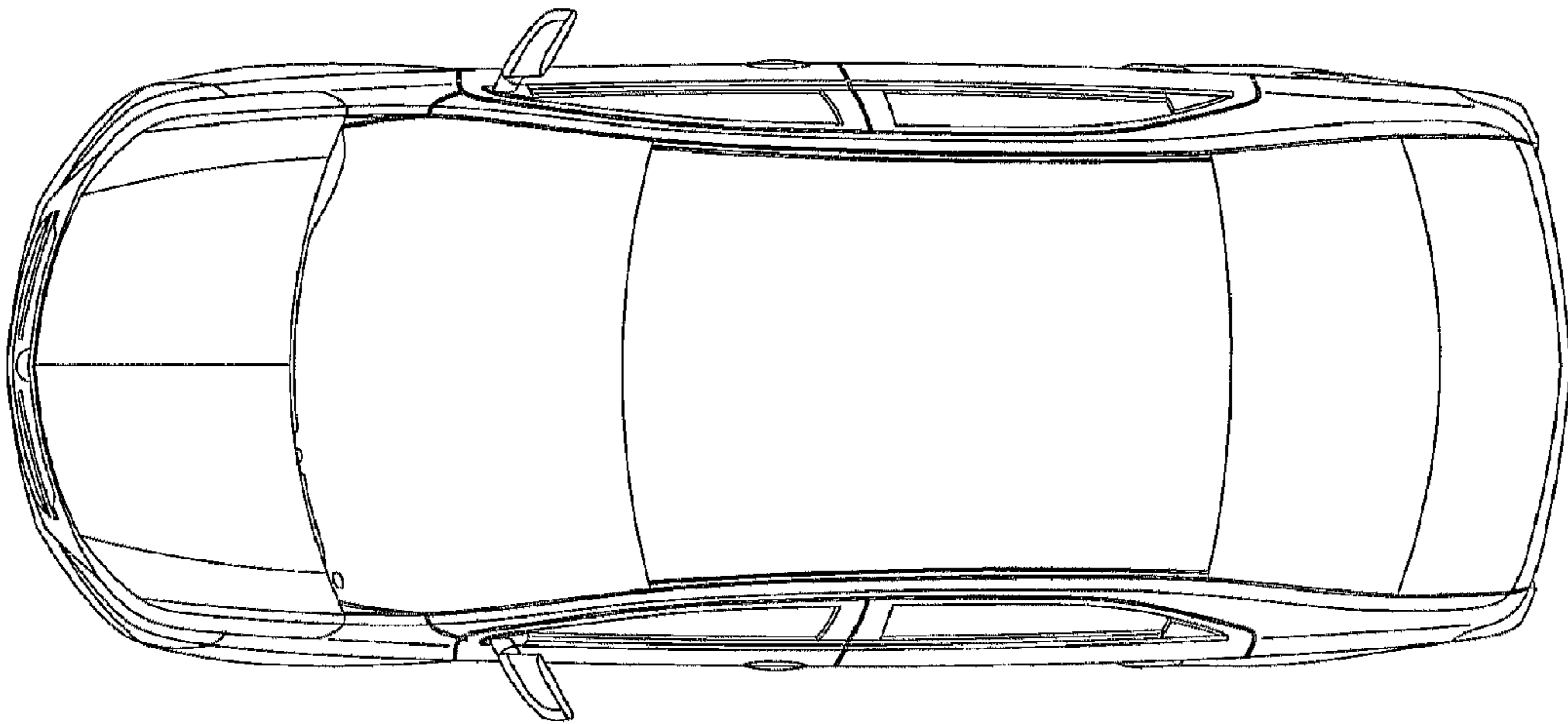

Fig-4

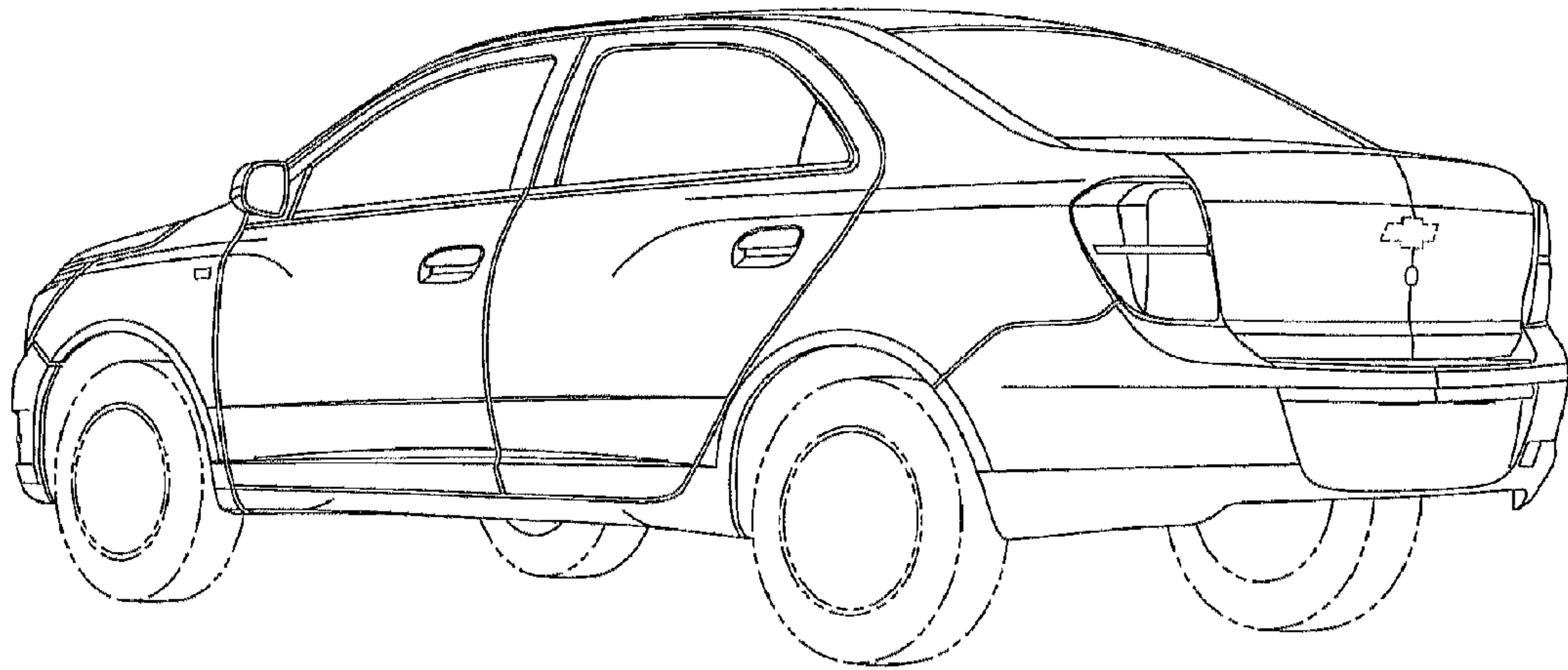

Fig-5

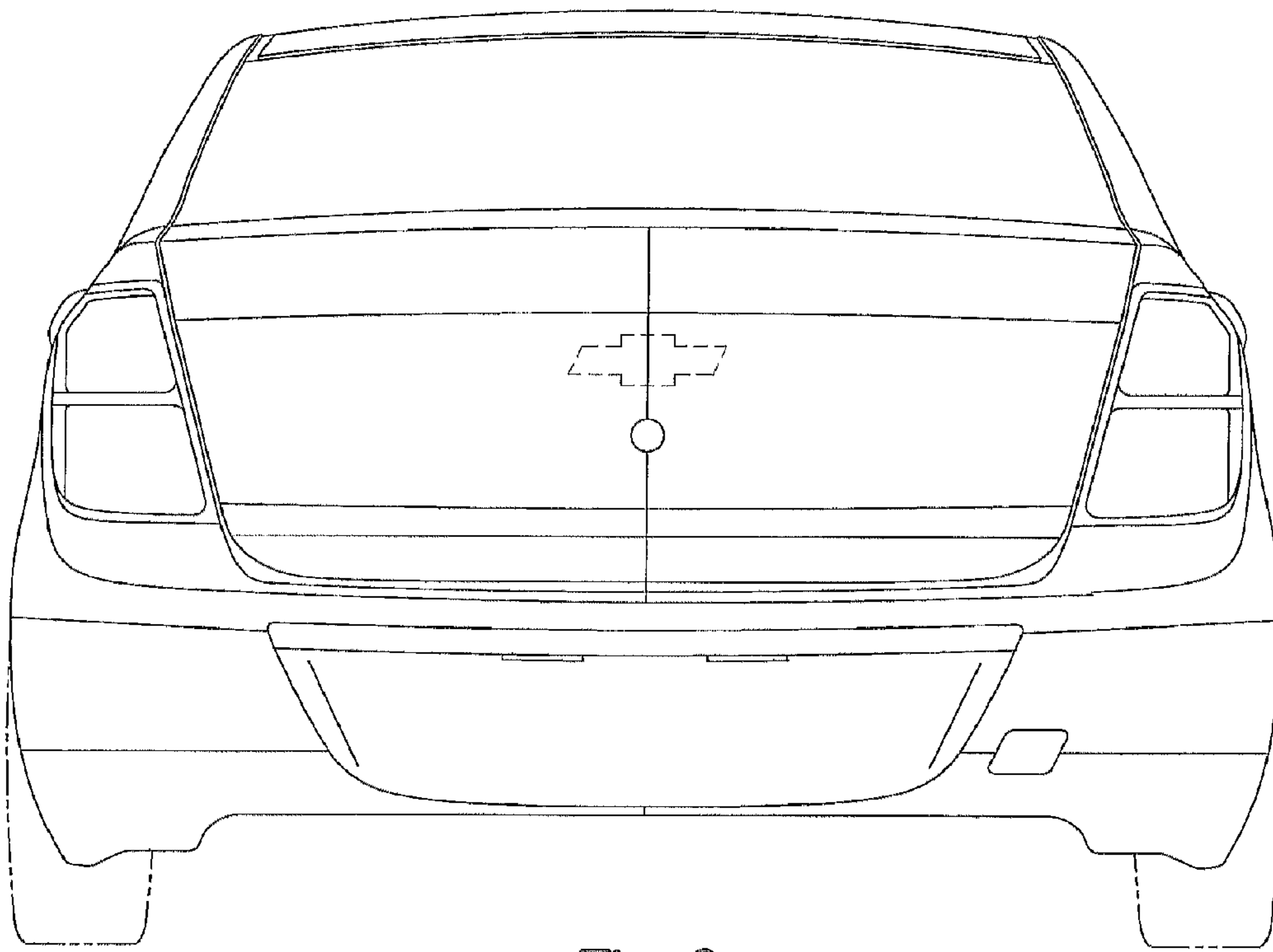

Fig-6