



US00D667874S

(12) **United States Design Patent**  
**Chen**

(10) **Patent No.:** **US D667,874 S**

(45) **Date of Patent:** **\*\* Sep. 25, 2012**

(54) **MARKER**

(75) Inventor: **Bei Chen**, Ningbo (CN)

(73) Assignee: **Beifa Group Co., Ltd.**, Ningbo (CN)

(\*\*) Term: **14 Years**

(21) Appl. No.: **29/392,721**

(22) Filed: **May 25, 2011**

(30) **Foreign Application Priority Data**

Nov. 26, 2010 (CN) ..... 201030637402

(51) **LOC (9) Cl.** ..... **19-06**

(52) **U.S. Cl.** ..... **D19/41**

(58) **Field of Classification Search** ..... D19/35,  
D19/36, 41-51, 54-58; D14/411; 24/11 F,  
24/11 P, 11 R; 401/52, 99, 104-109, 192,  
401/195, 196

See application file for complete search history.

(56) **References Cited**

**U.S. PATENT DOCUMENTS**

D260,272 S	8/1981	Horntrich	
D268,935 S *	5/1983	Horntrich	D19/43
D279,224 S	6/1985	Wolbrom	
D295,537 S	5/1988	Davidson	
D301,486 S *	6/1989	Yuen	D19/36
D309,913 S *	8/1990	Shintani	D19/43
D318,294 S *	7/1991	Cho-Kai	D19/48
D324,879 S *	3/1992	Morgan	D19/36
D325,931 S *	5/1992	Sekiguchi	D19/43
D329,253 S	9/1992	Sekiguchi	
D331,070 S *	11/1992	Hu Huang	D19/43
D335,893 S *	5/1993	Hu	D19/43
D340,947 S	11/1993	Tu	

D353,227 S *	12/1994	Desgrippes	D28/85
D369,184 S	4/1996	Collins	
D388,119 S	12/1997	Kuramoto	
D389,515 S *	1/1998	Van Swieten	D19/36
D399,253 S *	10/1998	Raymond	D19/36
D446,389 S	8/2001	Zhou	
D470,529 S *	2/2003	Tu	D19/43
D476,363 S *	6/2003	Hung	D19/43
D482,065 S *	11/2003	Hung	D19/36
D500,081 S *	12/2004	Hung	D19/43
D508,262 S	8/2005	Reichmann	
D559,311 S *	1/2008	Qiu et al.	D19/43
D572,307 S	7/2008	Qiu	
D607,052 S *	12/2009	Siegel	D19/43

\* cited by examiner

*Primary Examiner* — Elizabeth Albert

(74) *Attorney, Agent, or Firm* — Christensen O'Connor Johnson Kindness PLLC

(57) **CLAIM**

The ornamental design for a marker, as shown and described.

**DESCRIPTION**

FIG. 1 is a lower front right perspective view of a marker showing my new design;

FIG. 2 is a front elevation view thereof;

FIG. 3 is a rear elevation view thereof;

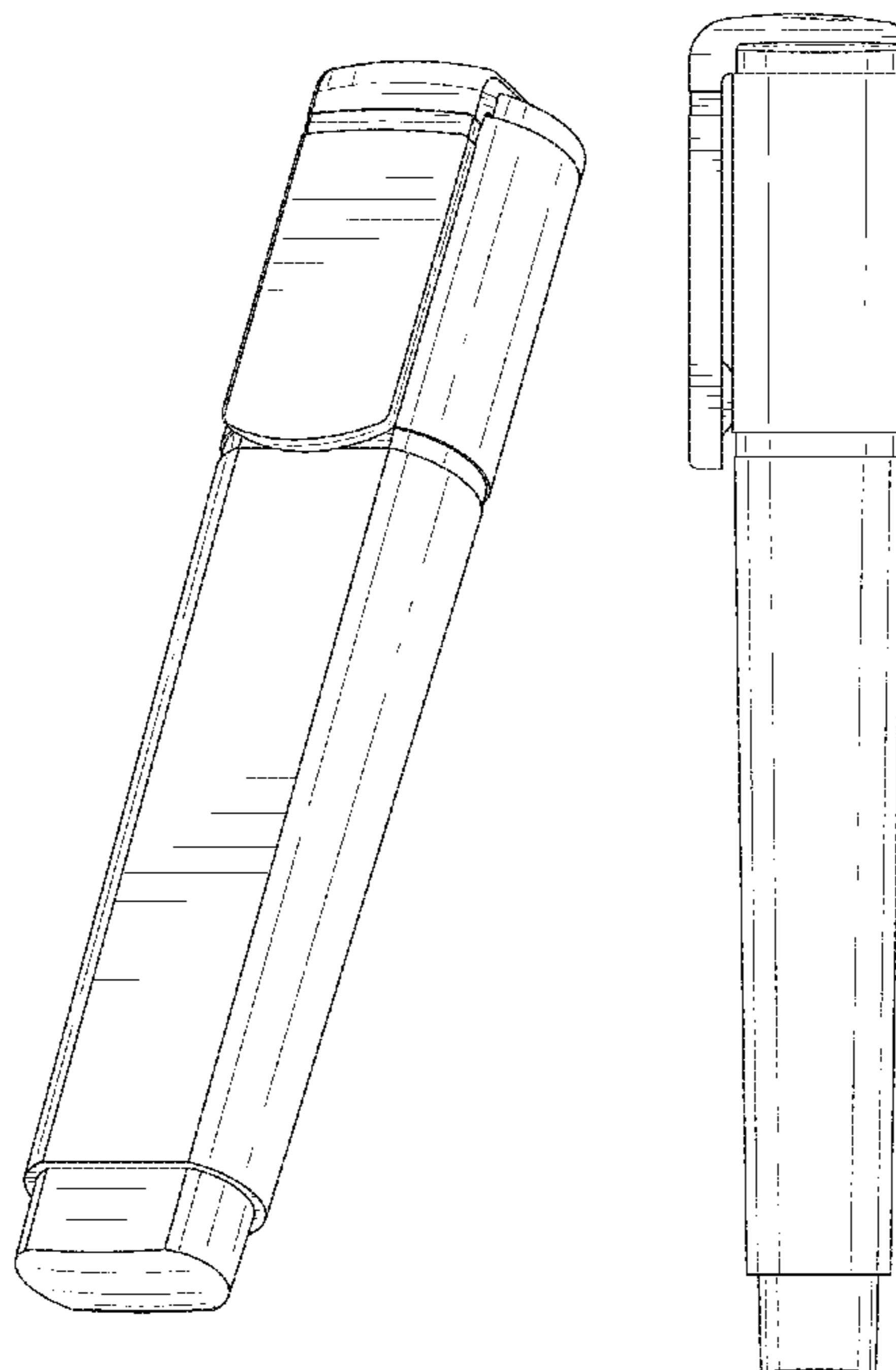
FIG. 4 is a right side elevation view thereof, with the left side elevation view being a mirror image of the right side elevation view;

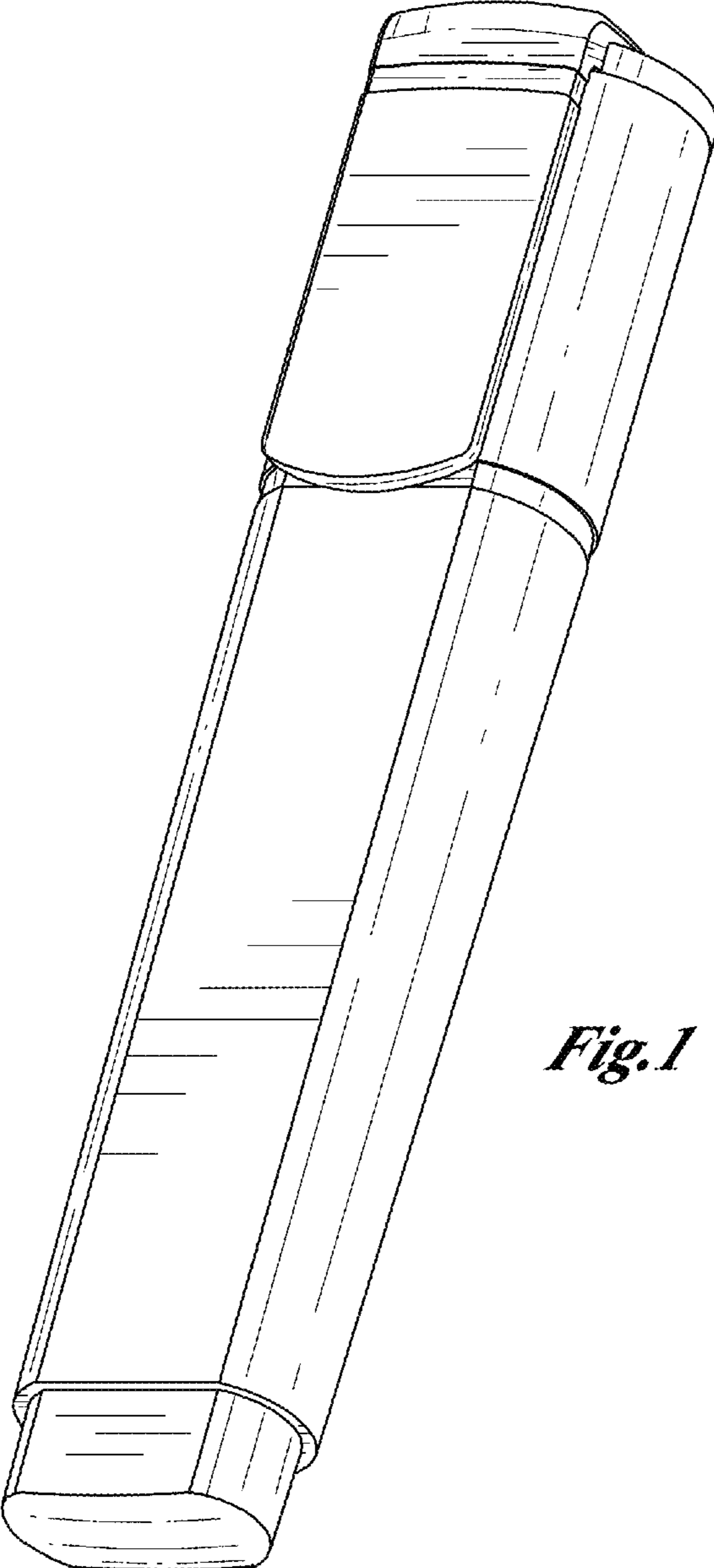
FIG. 5 is an enlarged top plan view thereof; and,

FIG. 6 is an enlarged bottom plan view thereof.

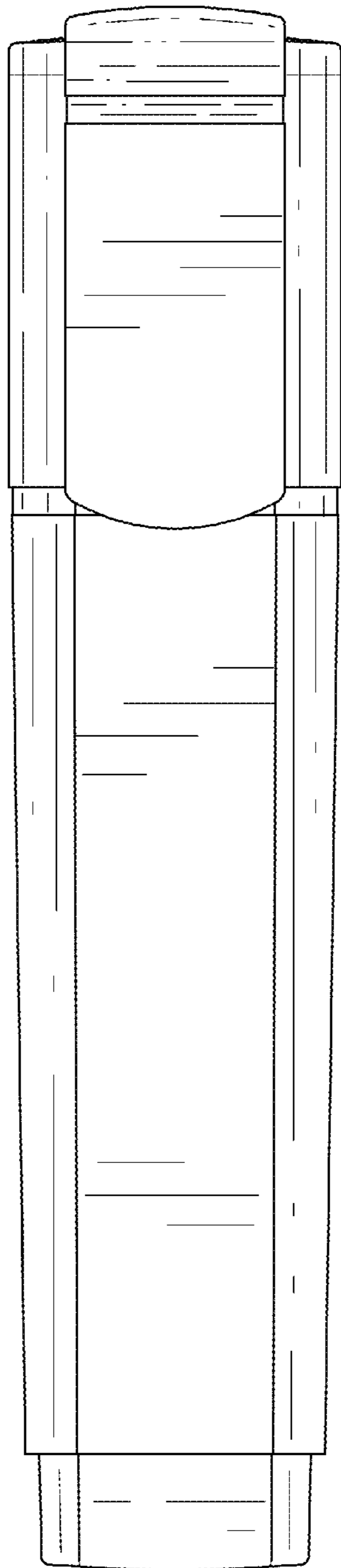
The broken lines shown in FIGS. 3, 4, and 5 illustrate environmental subject matter and form no part of the claimed design.

**1 Claim, 4 Drawing Sheets**

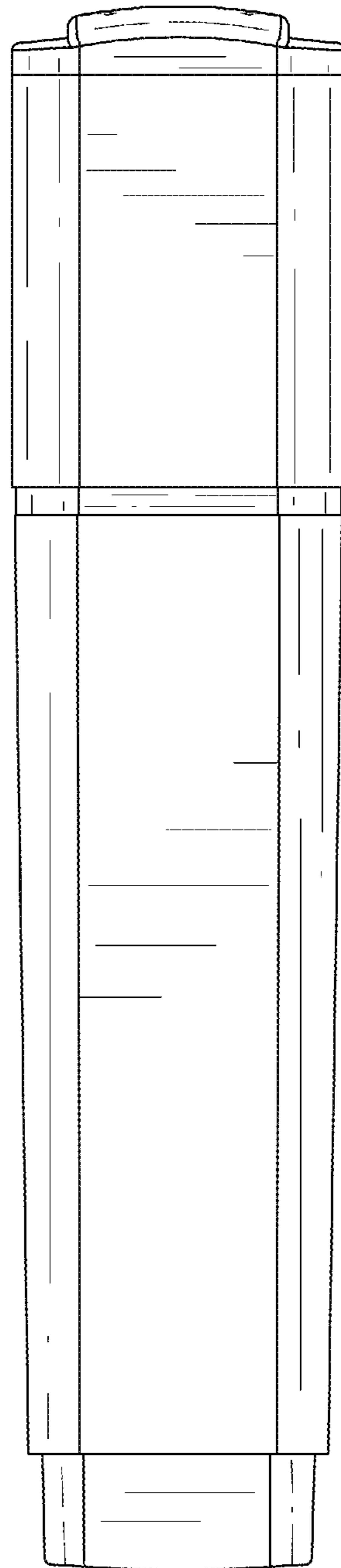




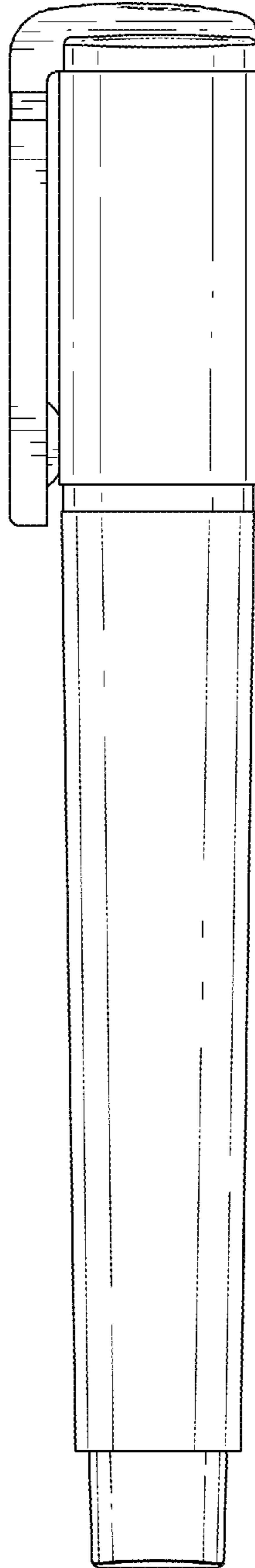
*Fig.1*



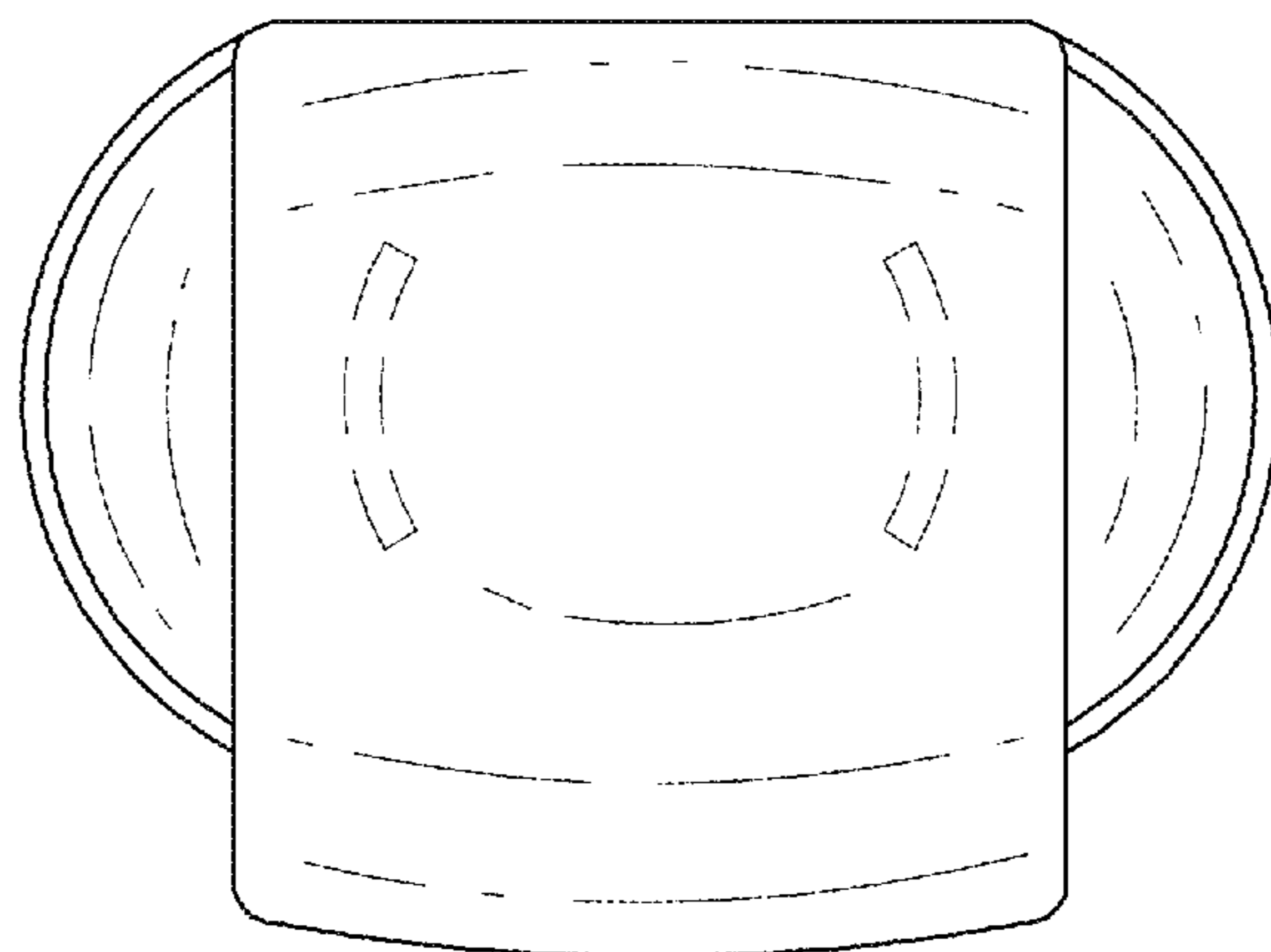
*Fig. 2*



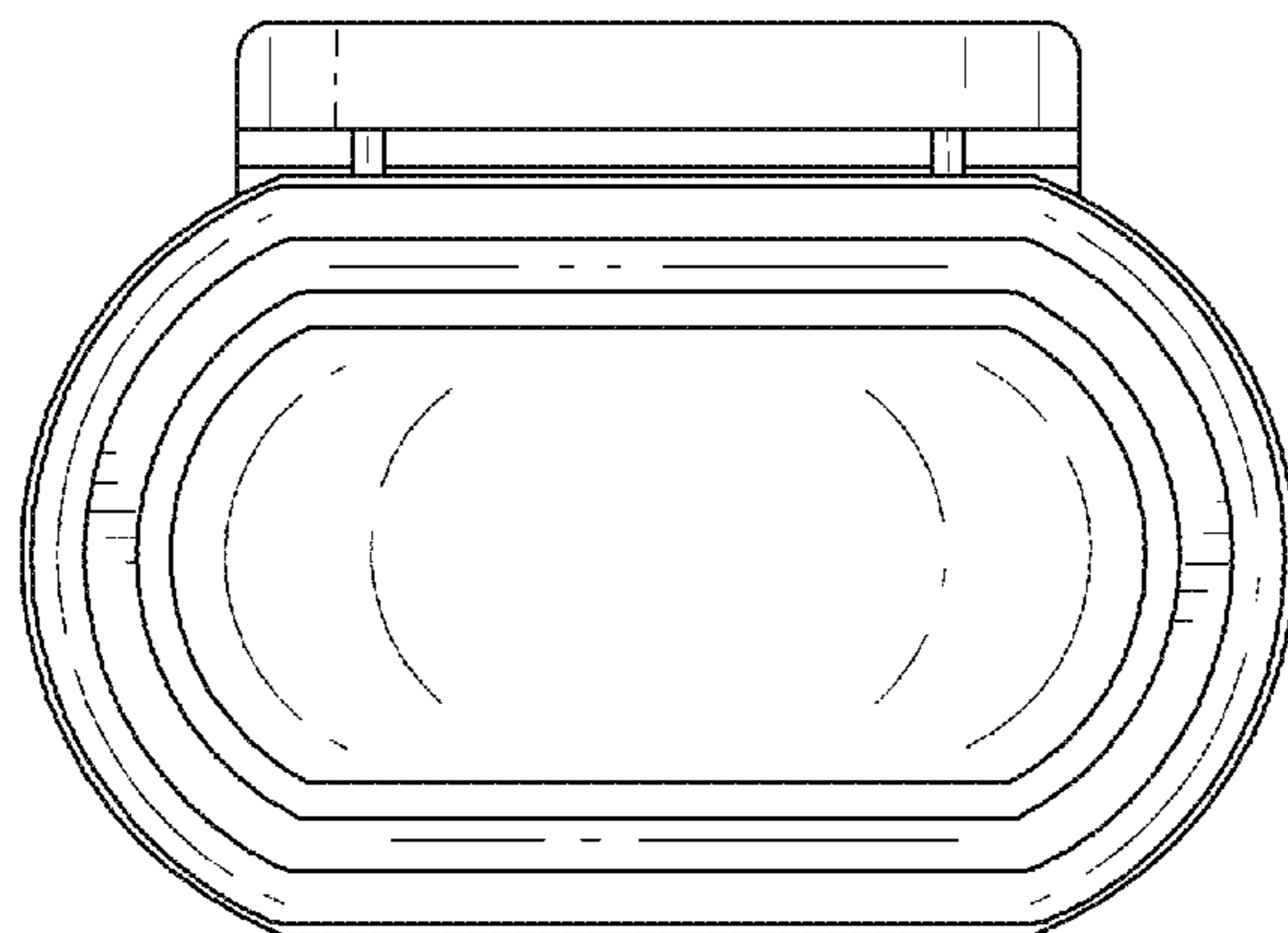
*Fig. 3*



*Fig. 4*



*Fig. 5*



*Fig. 6*