



US00D667857S

(12) **United States Design Patent**  
**Hidaka**

(10) **Patent No.:** **US D667,857 S**

(45) **Date of Patent:** **\*\* Sep. 25, 2012**

(54) **ELECTRODE TIP FOR RESISTIVE WELDERS**

(75) Inventor: **Masato Hidaka**, Kanagawa (JP)

(73) Assignee: **SMK Co., Ltd.**, Kanagawa (JP)

(\*\*) Term: **14 Years**

(21) Appl. No.: **29/351,277**

(22) Filed: **Dec. 3, 2009**

(30) **Foreign Application Priority Data**

Jun. 4, 2009 (JP) ..... 2009-003738

(51) **LOC (9) Cl.** ..... **15-09**

(52) **U.S. Cl.** ..... **D15/144**

(58) **Field of Classification Search** ..... D15/144,  
D15/144.1, 144.2; 19/108; 219/110, 114,  
219/121.44-121.5; 313/231.31; 323/205,  
323/211, 212, 244, 246, 345

See application file for complete search history.

(56) **References Cited**

**U.S. PATENT DOCUMENTS**

2,250,645 A \* 7/1941 Meadowcroft et al. .... 219/120  
2,418,781 A \* 4/1947 Lewis ..... 219/119  
D231,834 S \* 6/1974 Gulrich ..... D15/144  
4,456,228 A \* 6/1984 Cable et al. .... 266/70  
D297,704 S \* 9/1988 Bulow ..... D8/30  
D362,860 S \* 10/1995 Carkhuff ..... D15/144  
D363,298 S \* 10/1995 Takemi ..... D15/144  
D367,660 S \* 3/1996 Weston ..... D15/145  
D371,058 S \* 6/1996 Walters ..... D8/30  
D384,682 S \* 10/1997 Turner et al. .... D15/144  
D409,211 S \* 5/1999 Hidaka ..... D15/144  
D417,459 S \* 12/1999 Shintani et al. .... D15/144  
6,039,237 A \* 3/2000 Nakajima et al. .... 228/51  
6,559,407 B2 \* 5/2003 Chancey et al. .... 219/121.47  
D503,729 S \* 4/2005 de Leeuw et al. .... D15/144.2

D505,963 S \* 6/2005 Conway et al. .... D15/139  
D517,577 S \* 3/2006 Conway et al. .... D15/144  
D522,026 S \* 5/2006 Colson, Jr. .... D15/144  
D523,042 S \* 6/2006 Conway et al. .... D15/144  
D523,043 S \* 6/2006 Conway et al. .... D15/144  
D524,336 S \* 7/2006 Conway et al. .... D15/144  
D525,273 S \* 7/2006 Conway et al. .... D15/144  
D527,401 S \* 8/2006 Mizuno et al. .... D15/144  
D535,672 S \* 1/2007 MacKenzie et al. .... D15/144  
D536,009 S \* 1/2007 MacKenzie et al. .... D15/144  
D549,255 S \* 8/2007 Axinte et al. .... D15/144  
7,538,294 B2 \* 5/2009 Scotchmer ..... 219/119  
D632,713 S \* 2/2011 Leonhartsberger et al. . D15/144  
2008/0230529 A1 \* 9/2008 Rich ..... 219/137.61

**FOREIGN PATENT DOCUMENTS**

JP 3148669 U 2/2009

\* cited by examiner

*Primary Examiner* — Patricia Palasik

(74) *Attorney, Agent, or Firm* — Lee Fredric Sharra

(57) **CLAIM**

The ornamental design for an electrode tip for resistive welders, as shown and described.

**DESCRIPTION**

FIG. 1 is a perspective view of the electrode tip for resistive welders showing the tip in an assembled alternate condition of use;

FIG. 2 is an exploded perspective view of the electrode tip for resistive welders of my new design;

FIG. 3 is a top perspective view thereof;

FIG. 4 is a top view thereof;

FIG. 5 is a front view thereof;

FIG. 6 is a left side view thereof;

FIG. 7 is a right side view thereof;

FIG. 8 is a back view thereof; and,

FIG. 9 is a bottom view thereof.

**1 Claim, 4 Drawing Sheets**

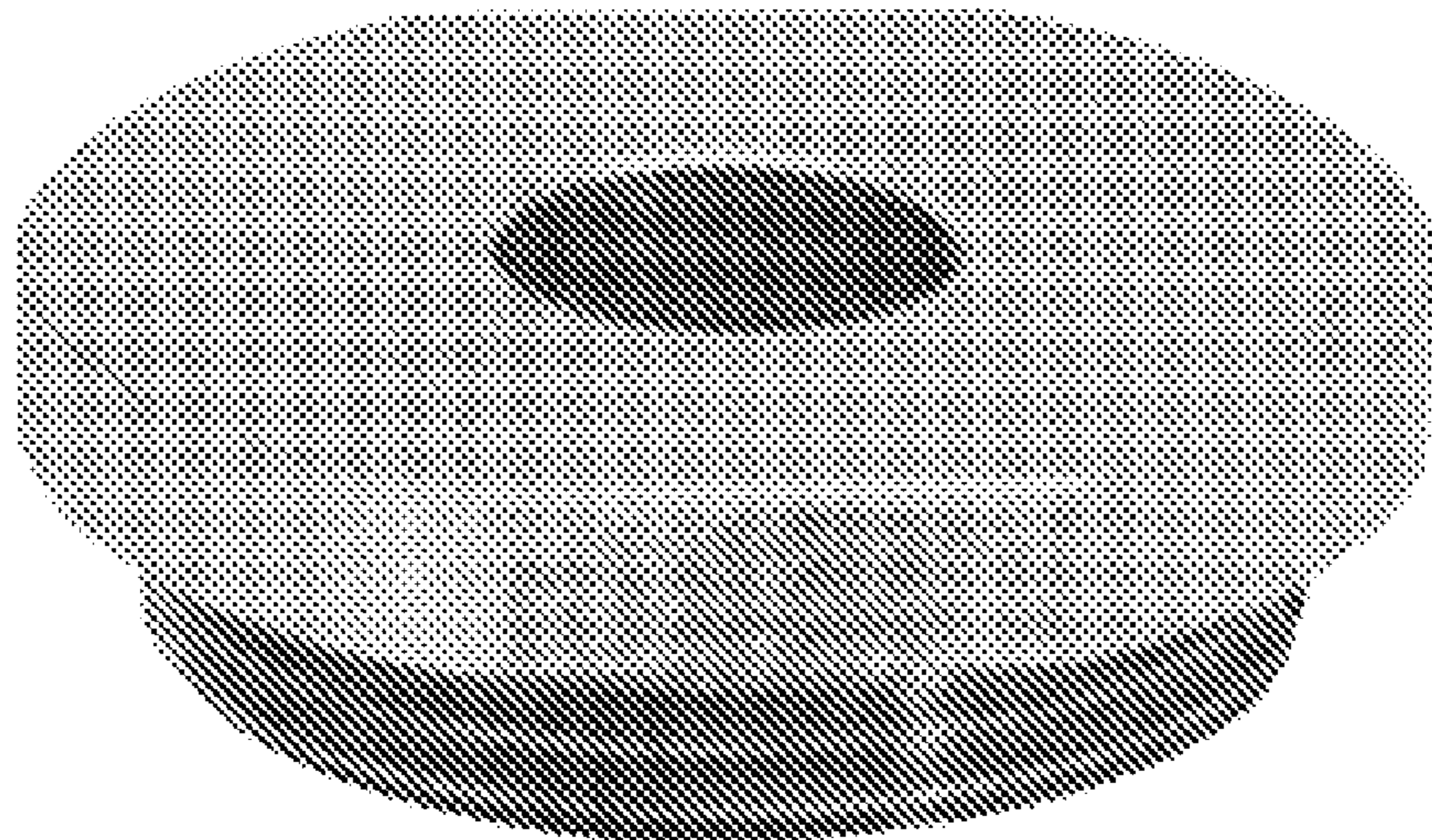

FIG. 1

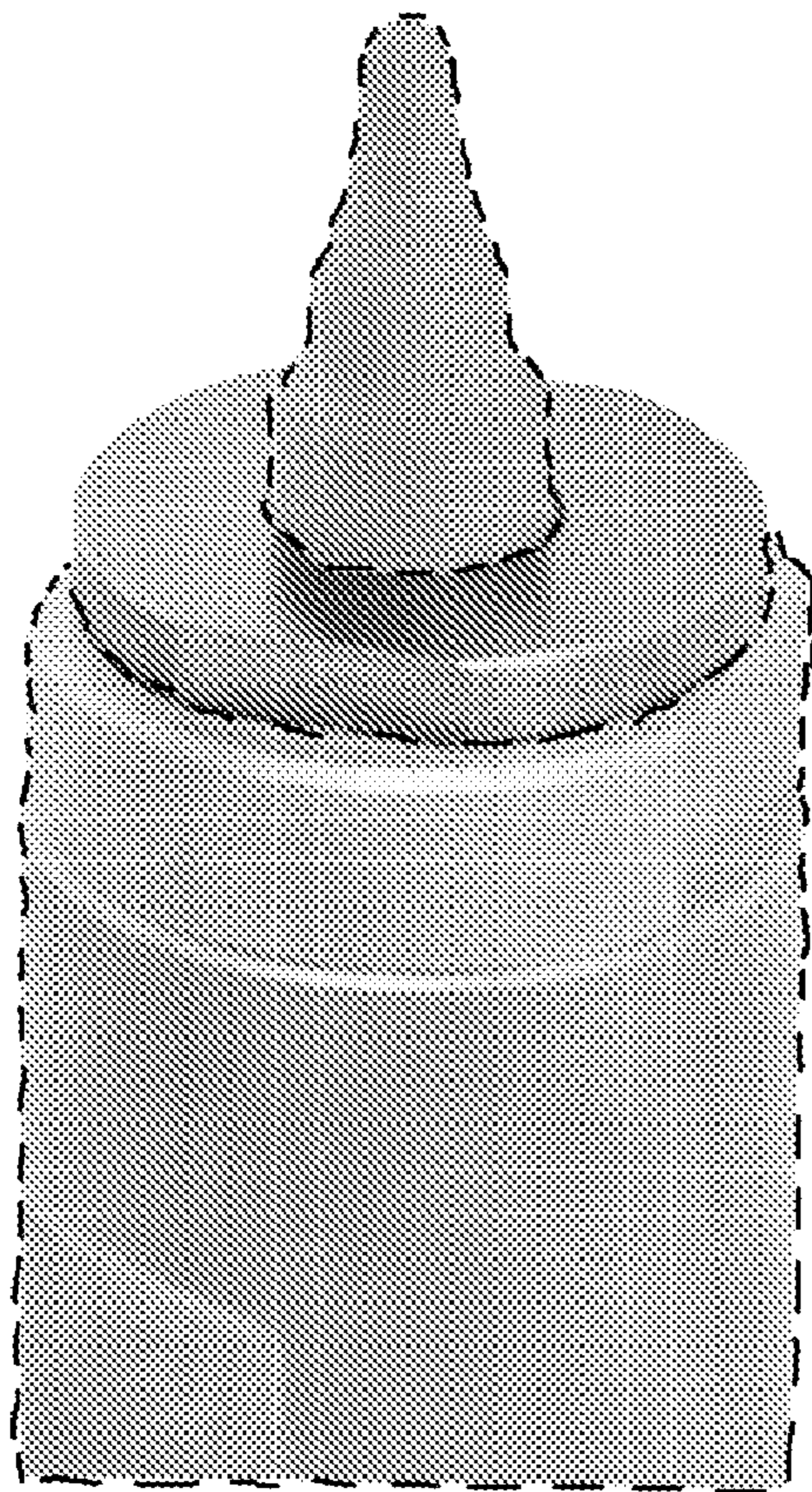

FIG. 2

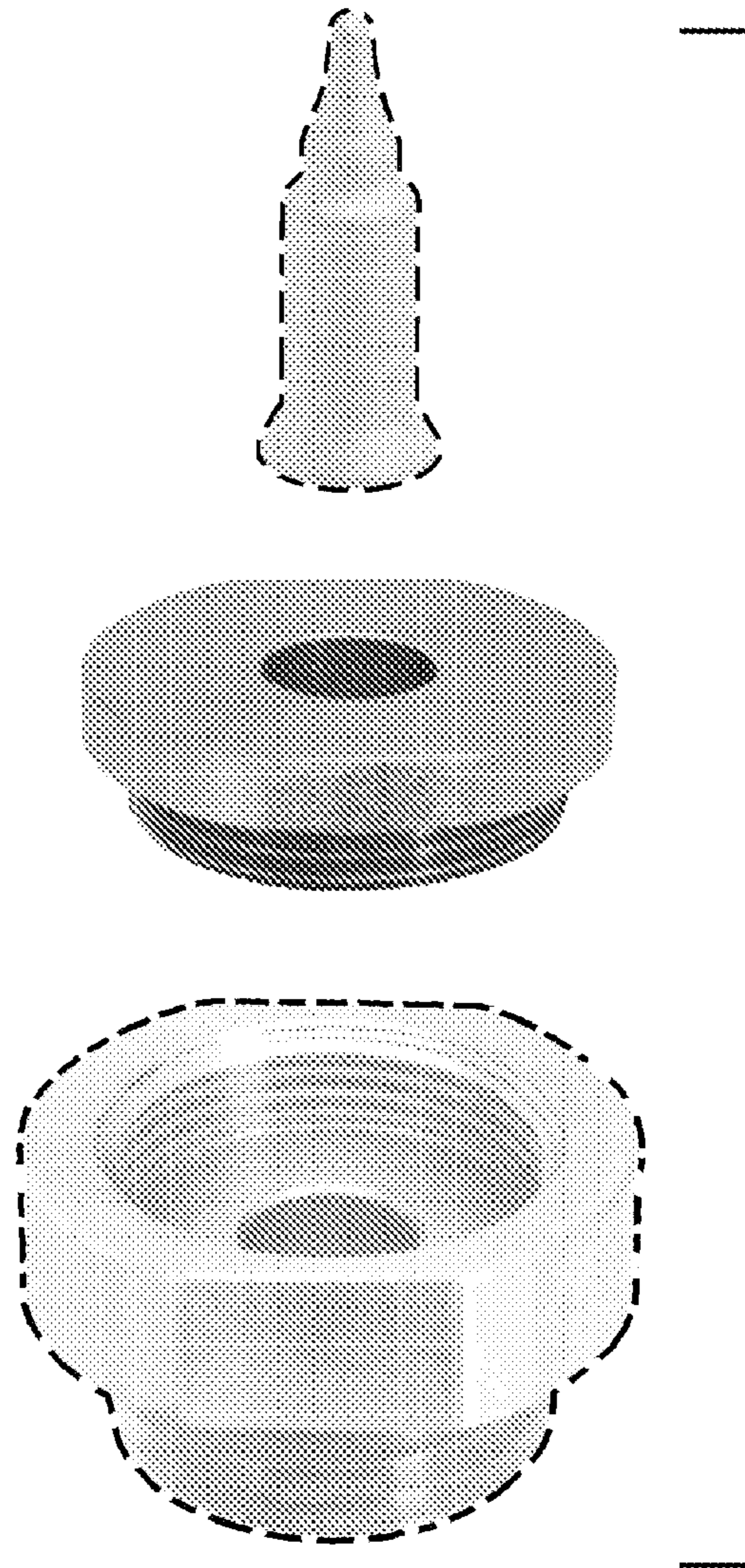

FIG. 3

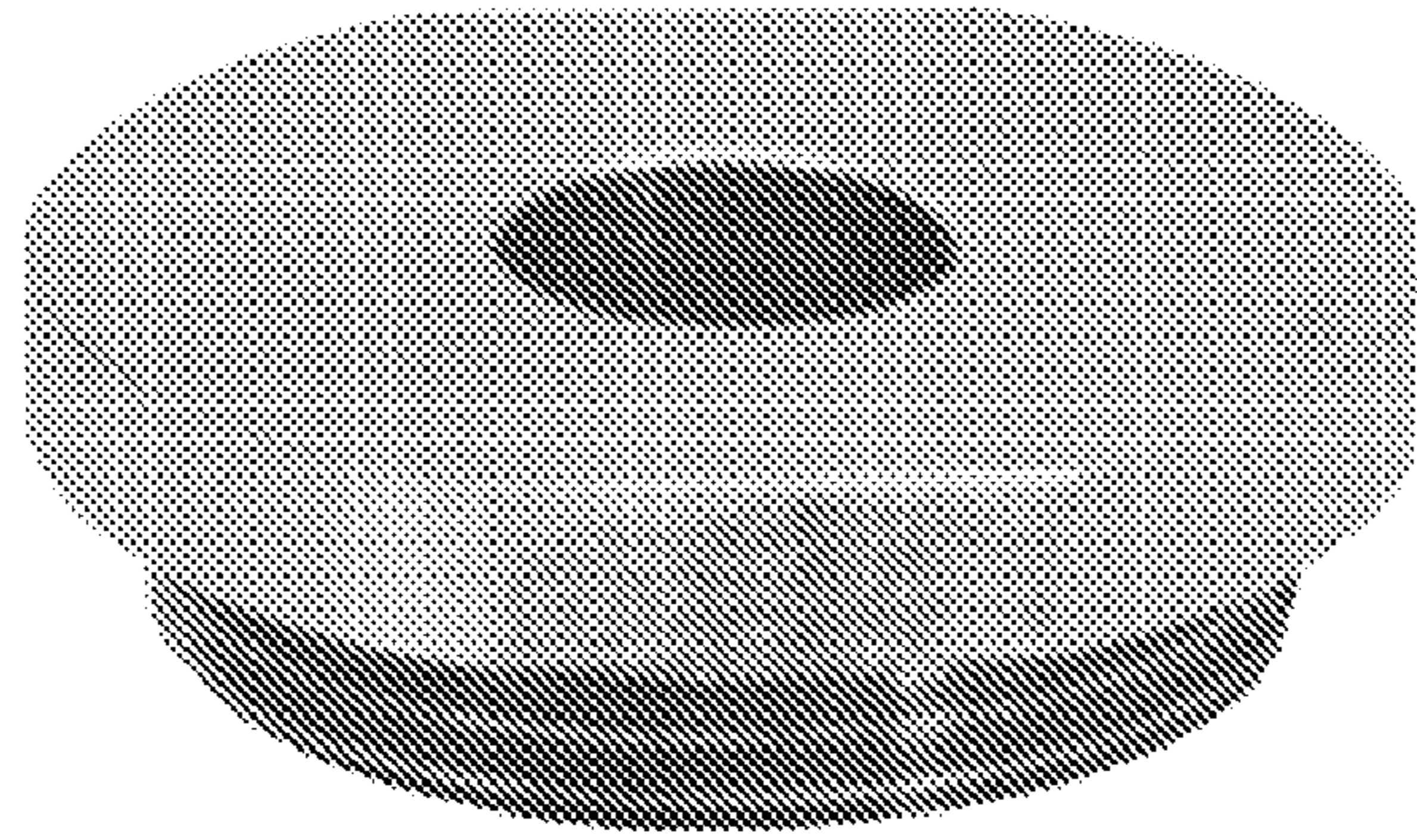

FIG. 4

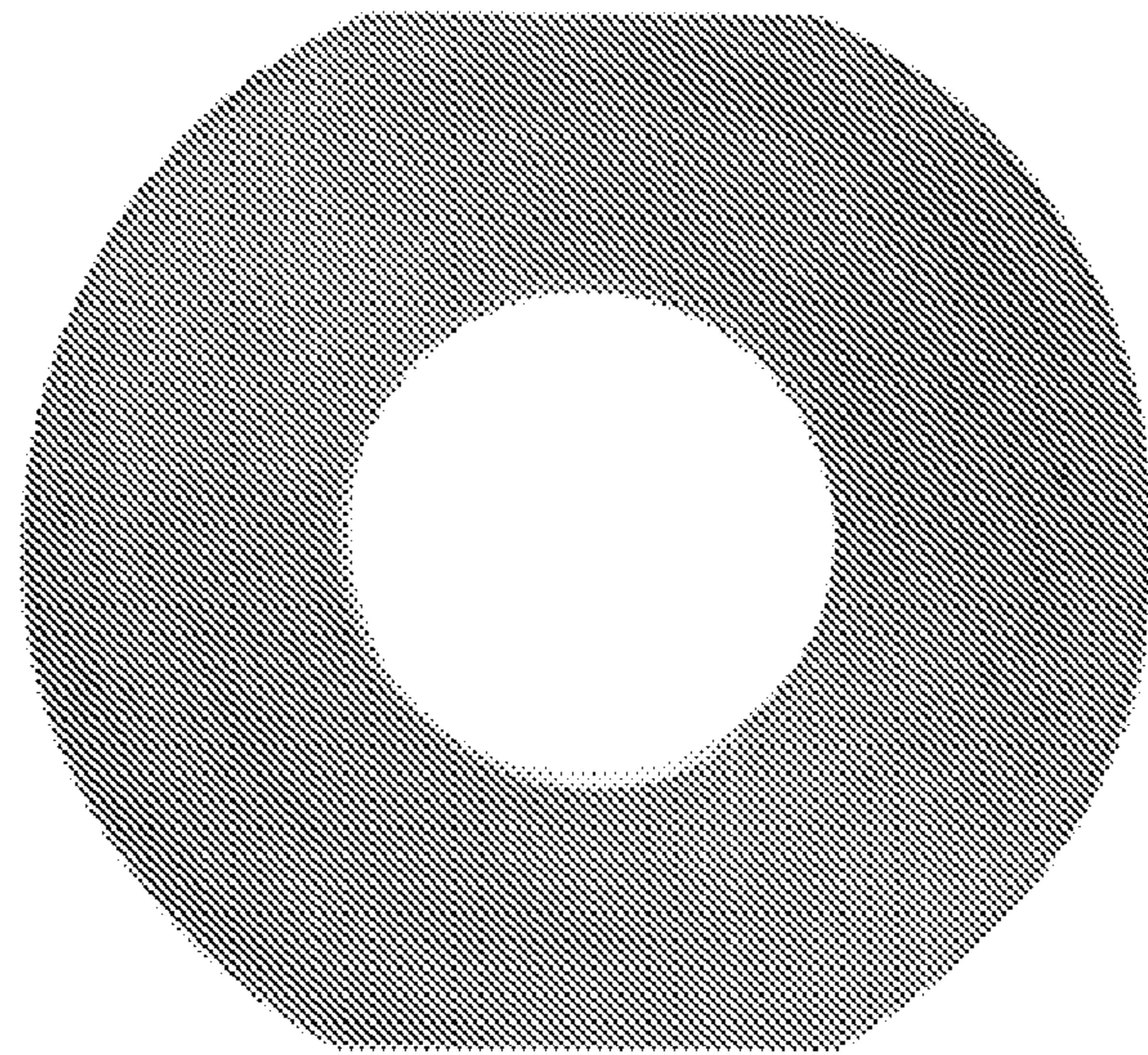

FIG. 5

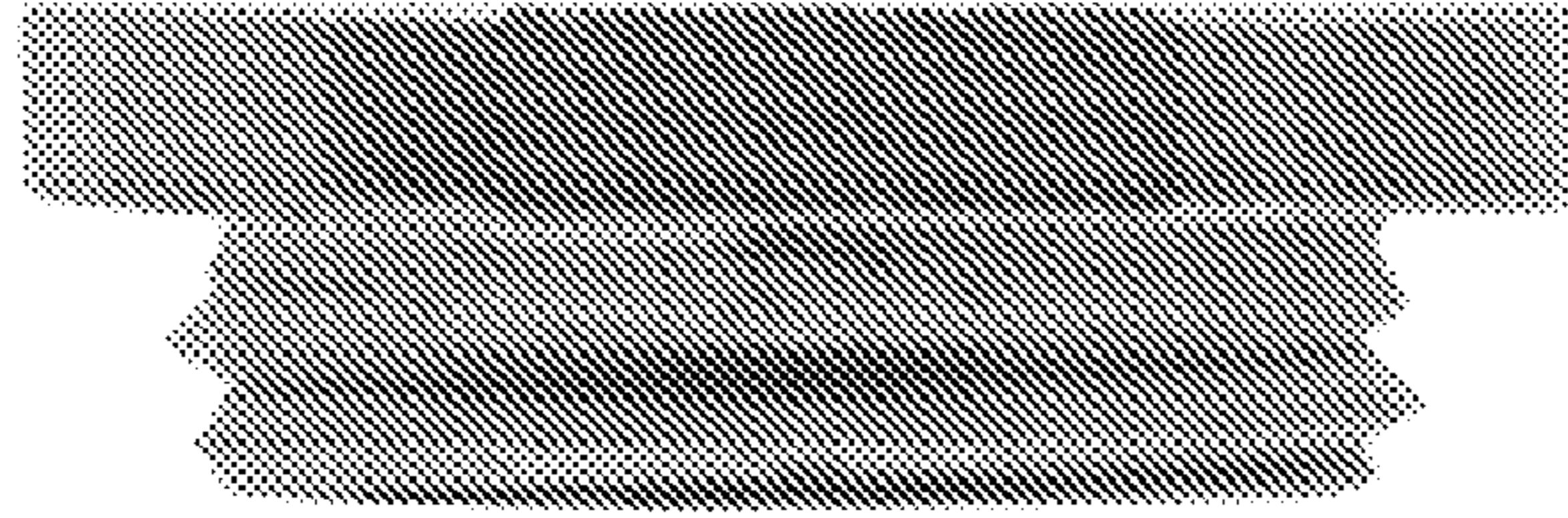

FIG. 6

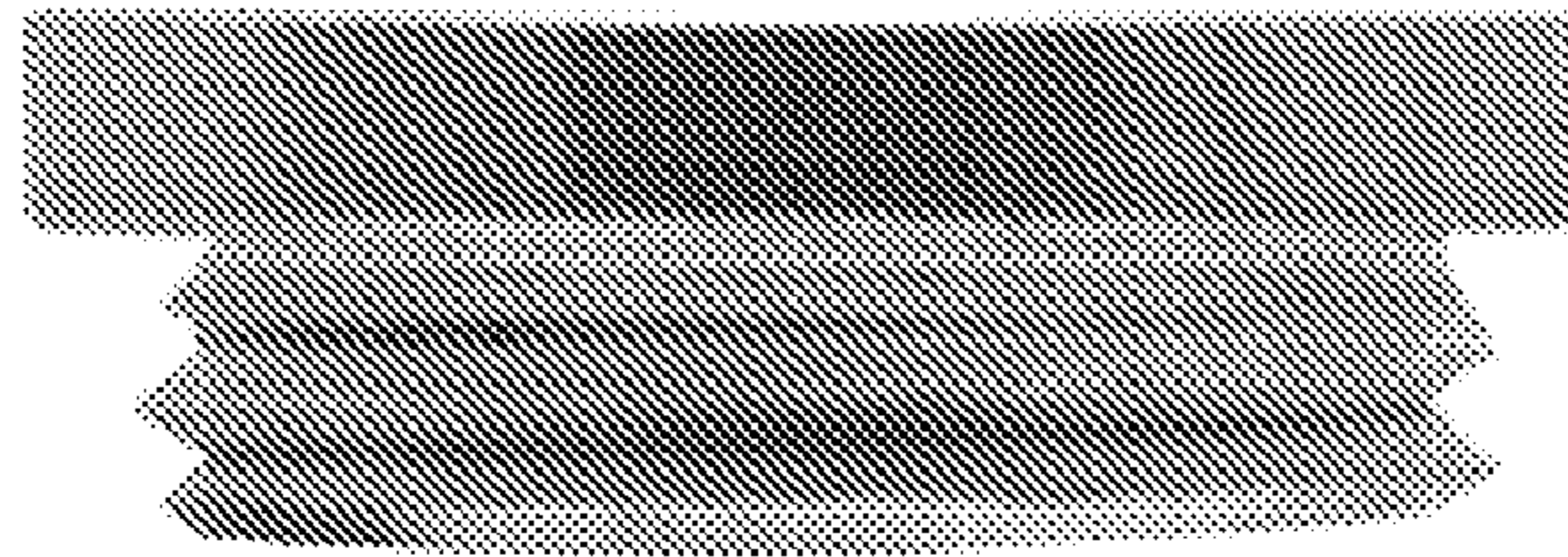

FIG. 7

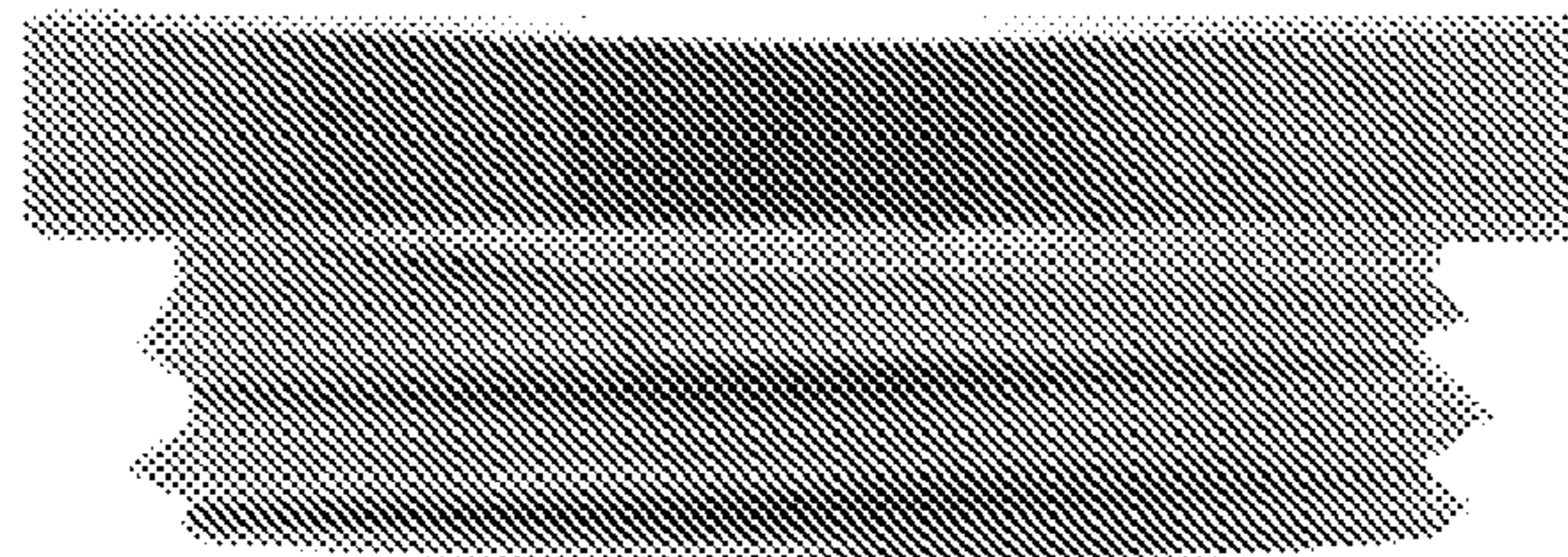

FIG. 8

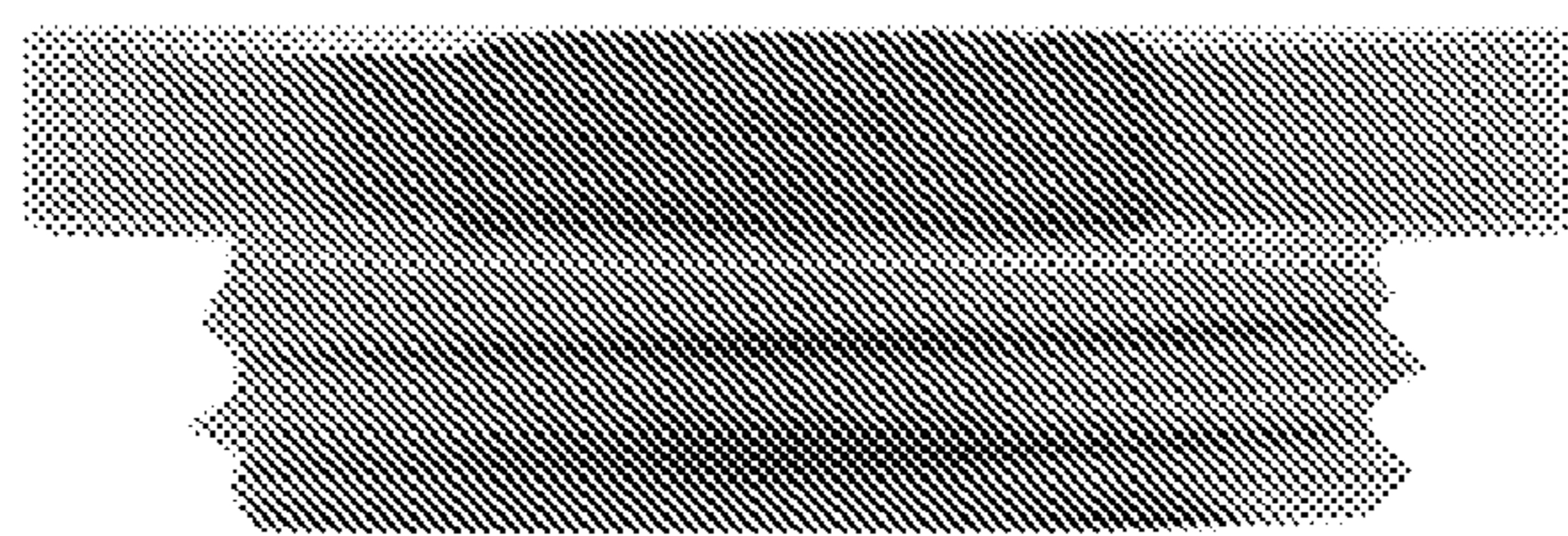

FIG. 9

