



US00D667576S

(12) **United States Design Patent**
Huet

(10) **Patent No.:** **US D667,576 S**

(45) **Date of Patent:** **** Sep. 18, 2012**

(54) **HEADLIGHT FOR A VEHICLE**

WO DM/071790 11/2009

* cited by examiner

(75) Inventor: **Nicolas Huet**, Munich (DE)

Primary Examiner — Marcus Jackson

(73) Assignee: **Bayerische Motoren Werke
Aktiengesellschaft**, Munich (DE)

(74) *Attorney, Agent, or Firm* — Crowell & Moring LLP

(**) Term: **14 Years**

(57) **CLAIM**

The ornamental design for a headlight for a vehicle, as shown and described.

(21) Appl. No.: **29/404,218**

(22) Filed: **Oct. 18, 2011**

DESCRIPTION

(30) **Foreign Application Priority Data**

Apr. 19, 2011 (DE) 40 2011 002 133

This application contains subject matter related to the following co-pending U.S. design patent application: Application Ser. No. 29/404,219, filed herewith and entitled "Headlight for a Vehicle".

(51) **LOC (9) Cl.** **D26-06**

FIG. 1 is a right perspective view of a first embodiment of a headlight for a vehicle according to my design; FIG. 2 is a left, elevated perspective view thereof; FIG. 3 is a front view thereof; FIG. 4 is a right side view thereof; and FIG. 5 is a top view thereof.

(52) **U.S. Cl.** **D26/28**

(58) **Field of Classification Search** D26/28-36;
362/459-468, 475-478, 485-487

See application file for complete search history.

FIG. 6 is a left perspective view of a second embodiment of the headlight for a vehicle according to my design, with the headlight for a vehicle for the opposite side of the vehicle being depicted in the first embodiment; FIG. 7 is a right, elevated perspective view thereof; FIG. 8 is a front view thereof; FIG. 9 is a left side view thereof; and, FIG. 10 is a top view thereof.

(56) **References Cited**

U.S. PATENT DOCUMENTS

D528,681 S *	9/2006	Nakahara	D26/28
D528,685 S *	9/2006	Yoshida	D26/28
D544,114 S *	6/2007	Ohta	D26/28
D544,614 S *	6/2007	Markefka	D26/28
D549,857 S *	8/2007	Lin	D26/28
D560,291 S *	1/2008	Koyama	D26/28
D561,358 S *	2/2008	Tachibana	D26/28
D593,691 S	6/2009	Habib		

The broken lines are for illustrative purposes only and form no part of the claimed design.

FOREIGN PATENT DOCUMENTS

WO DM/069951 10/2008

1 Claim, 6 Drawing Sheets

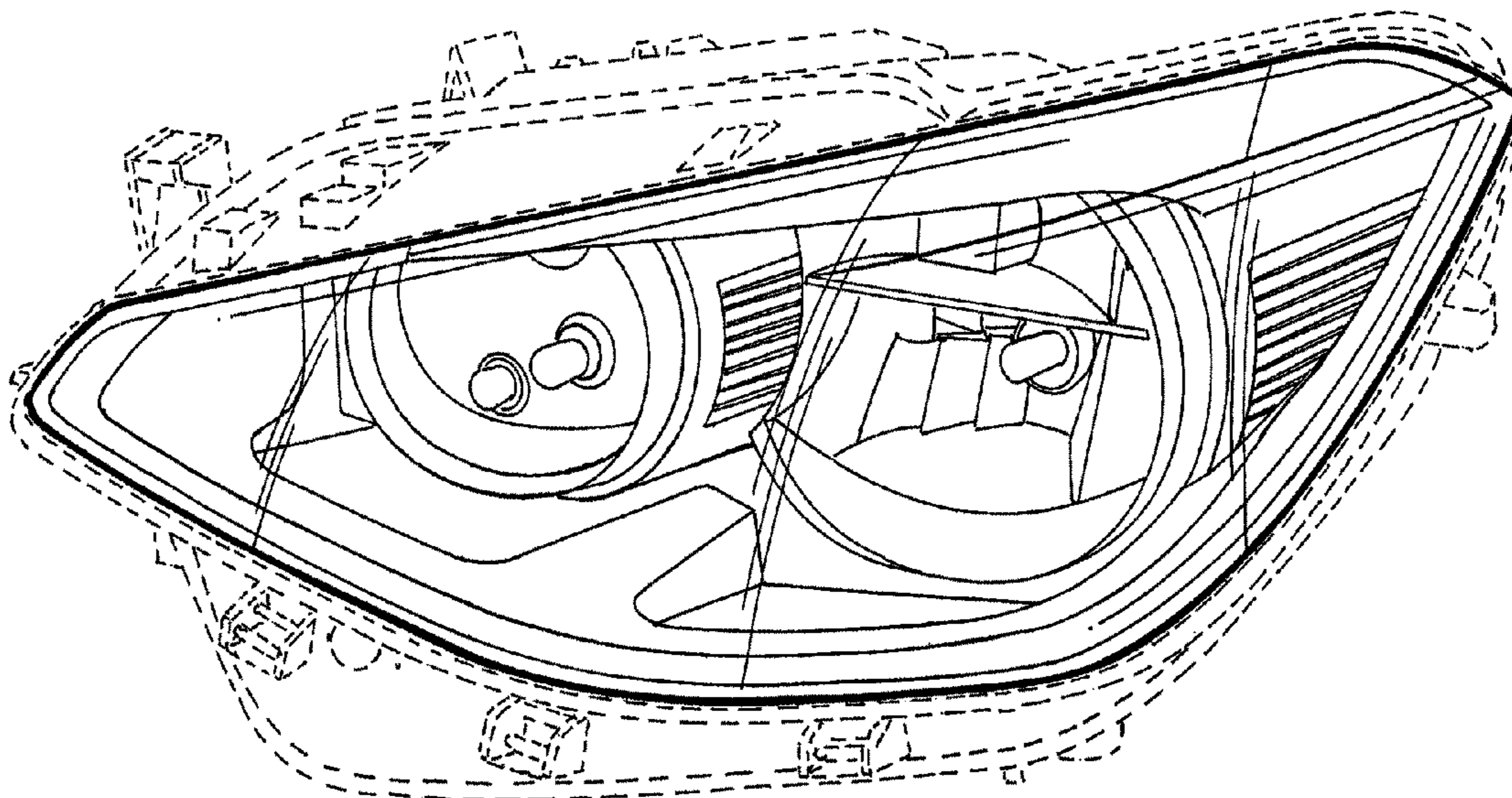

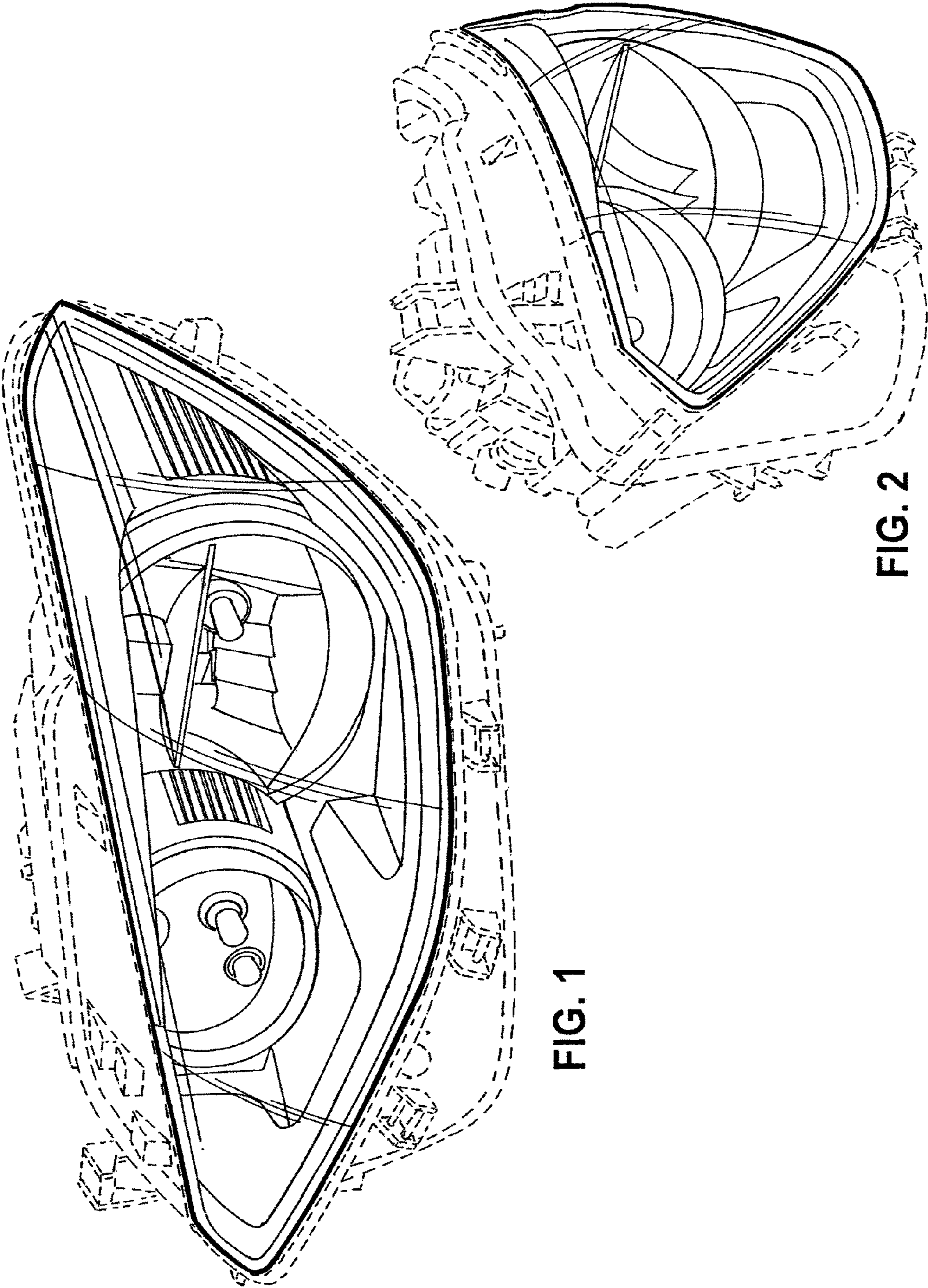

FIG. 1

FIG. 2

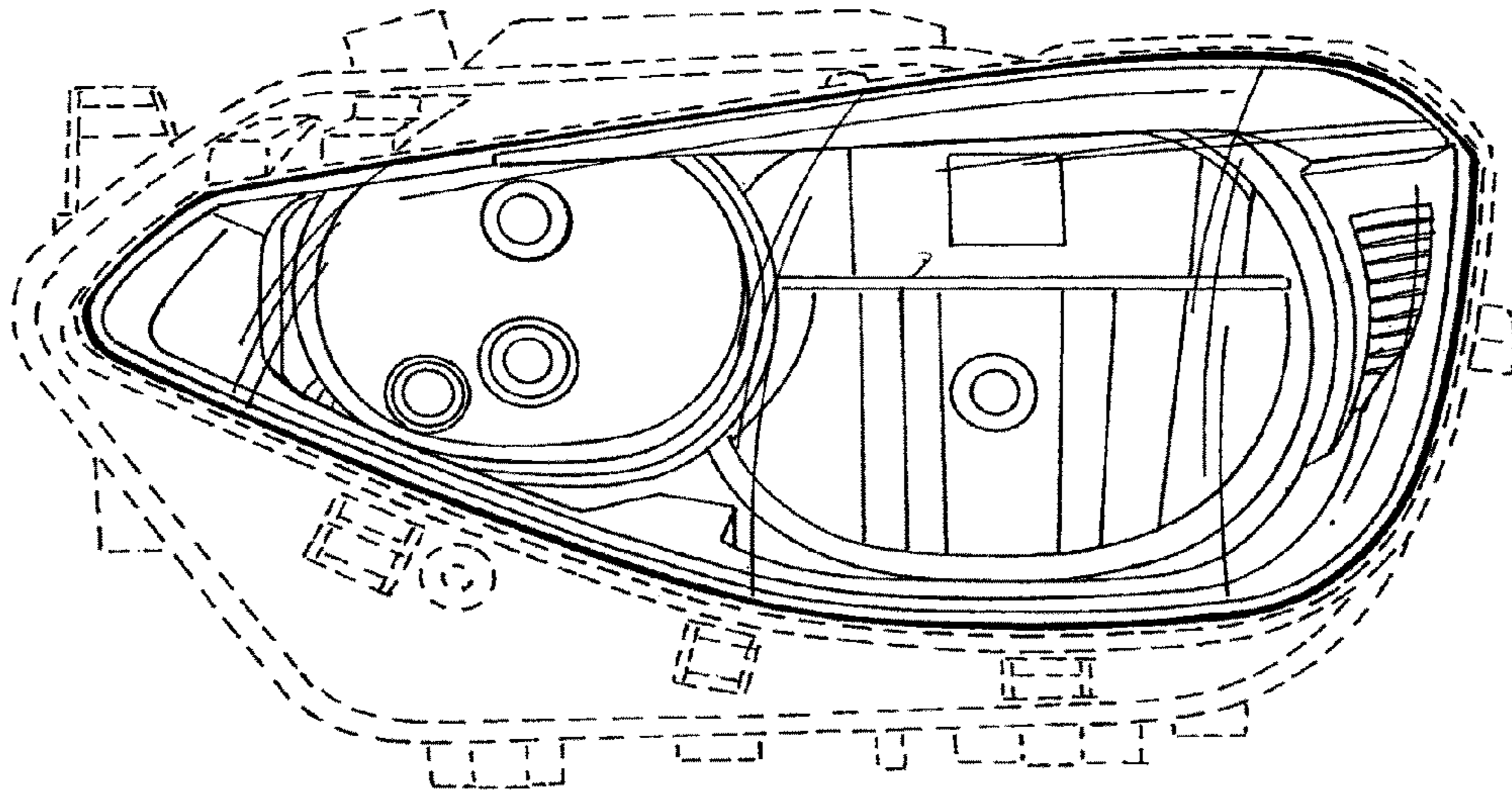

FIG. 3

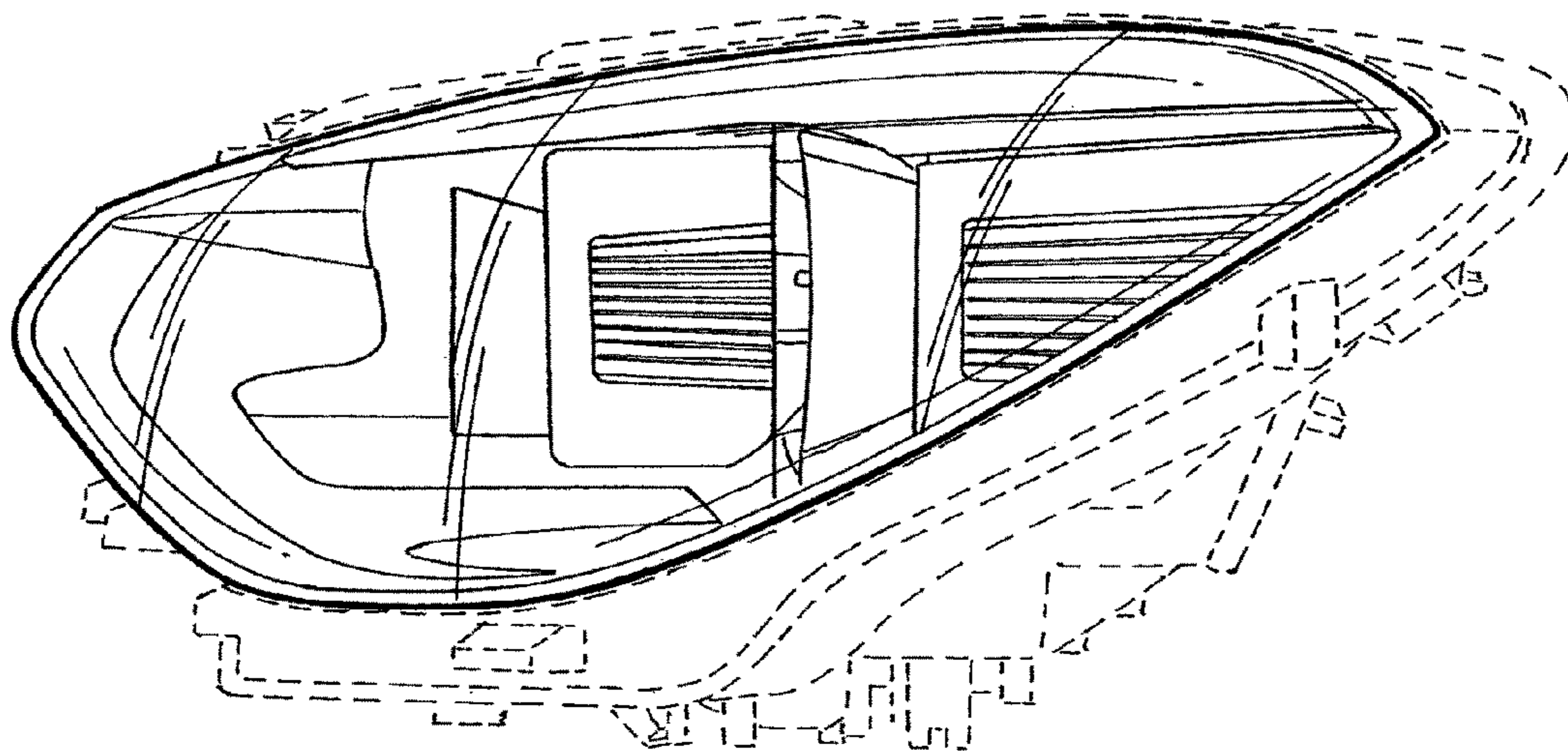

FIG. 4

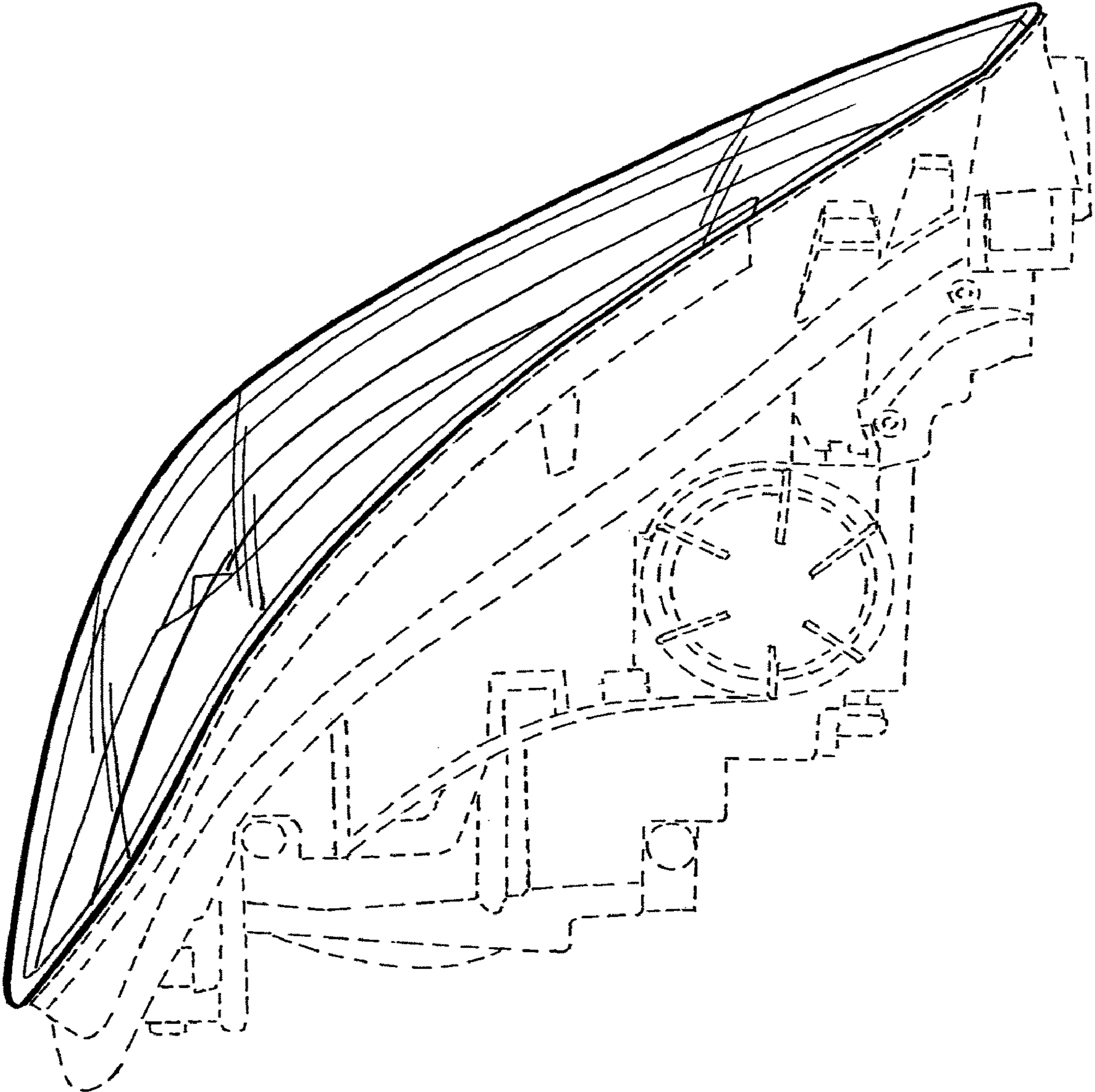

FIG. 5

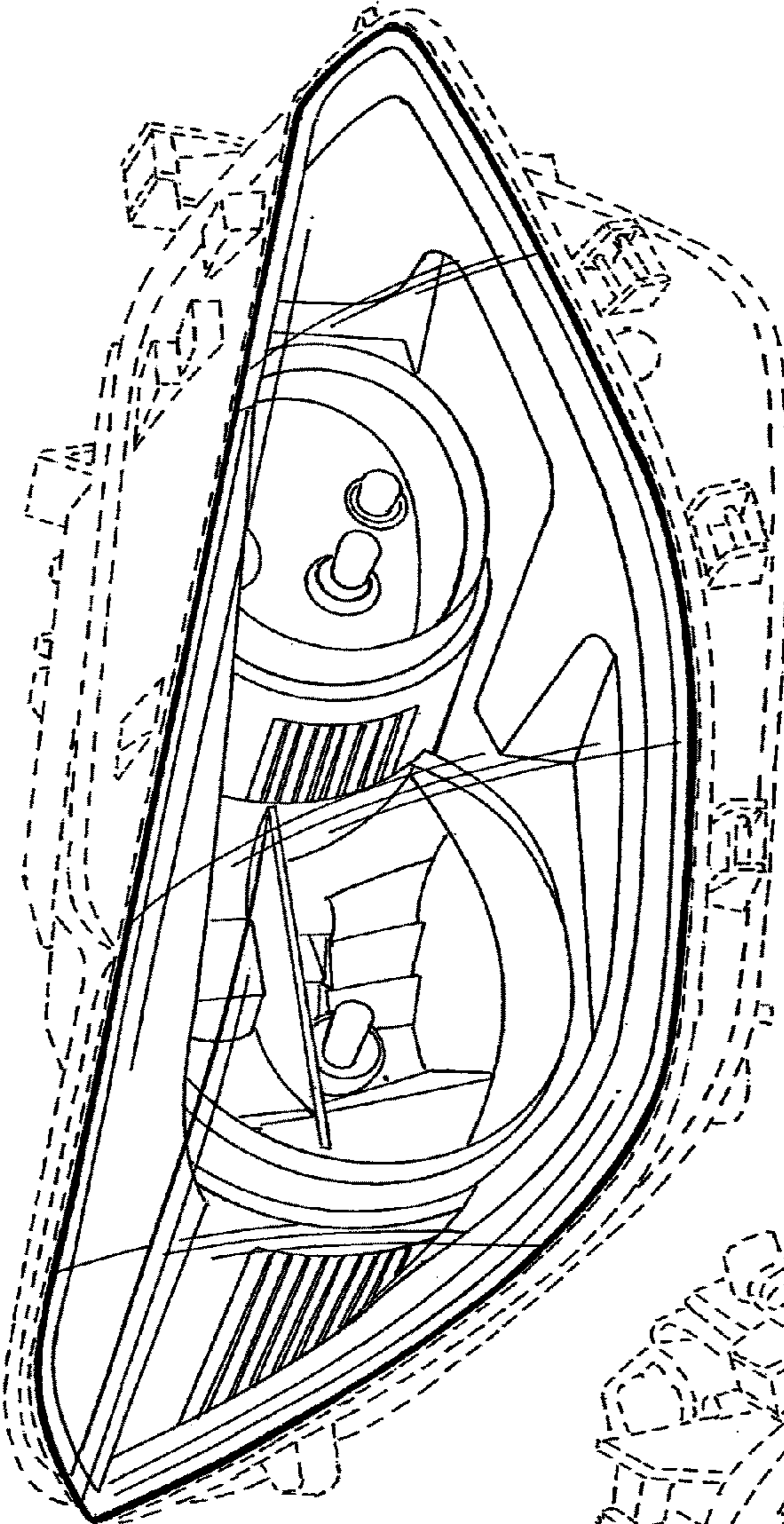

FIG. 6

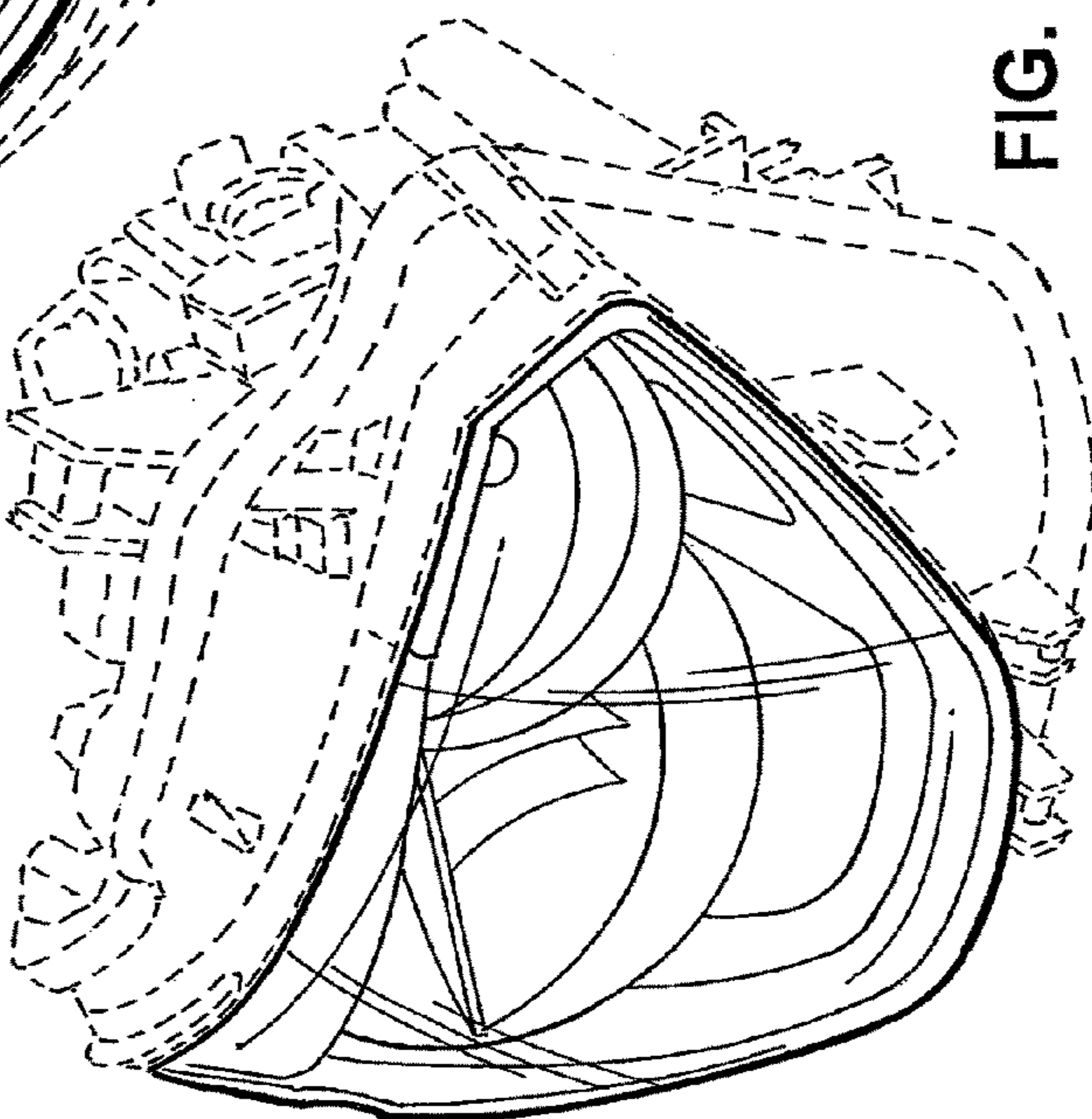

FIG. 7

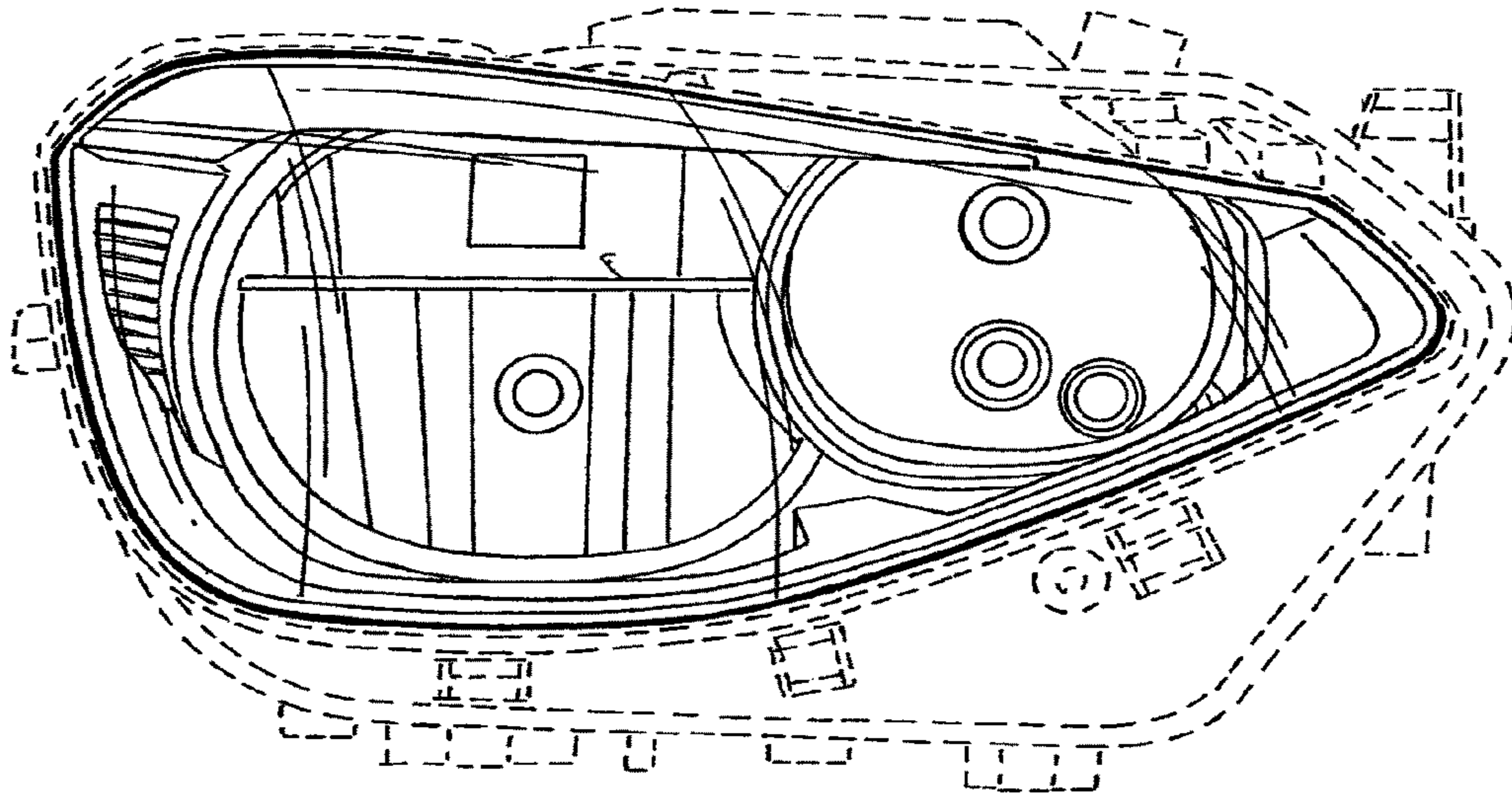

FIG. 8

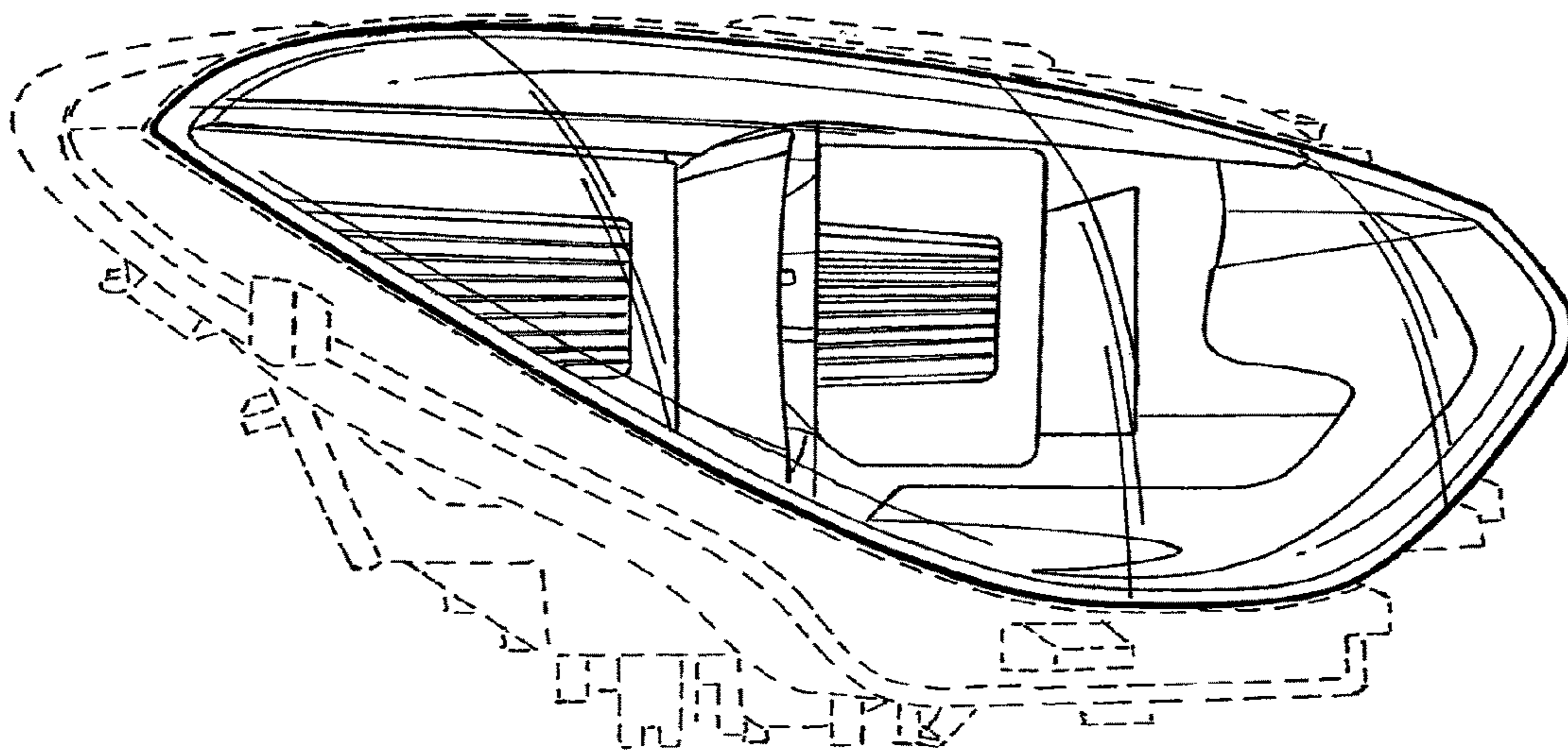

FIG. 9

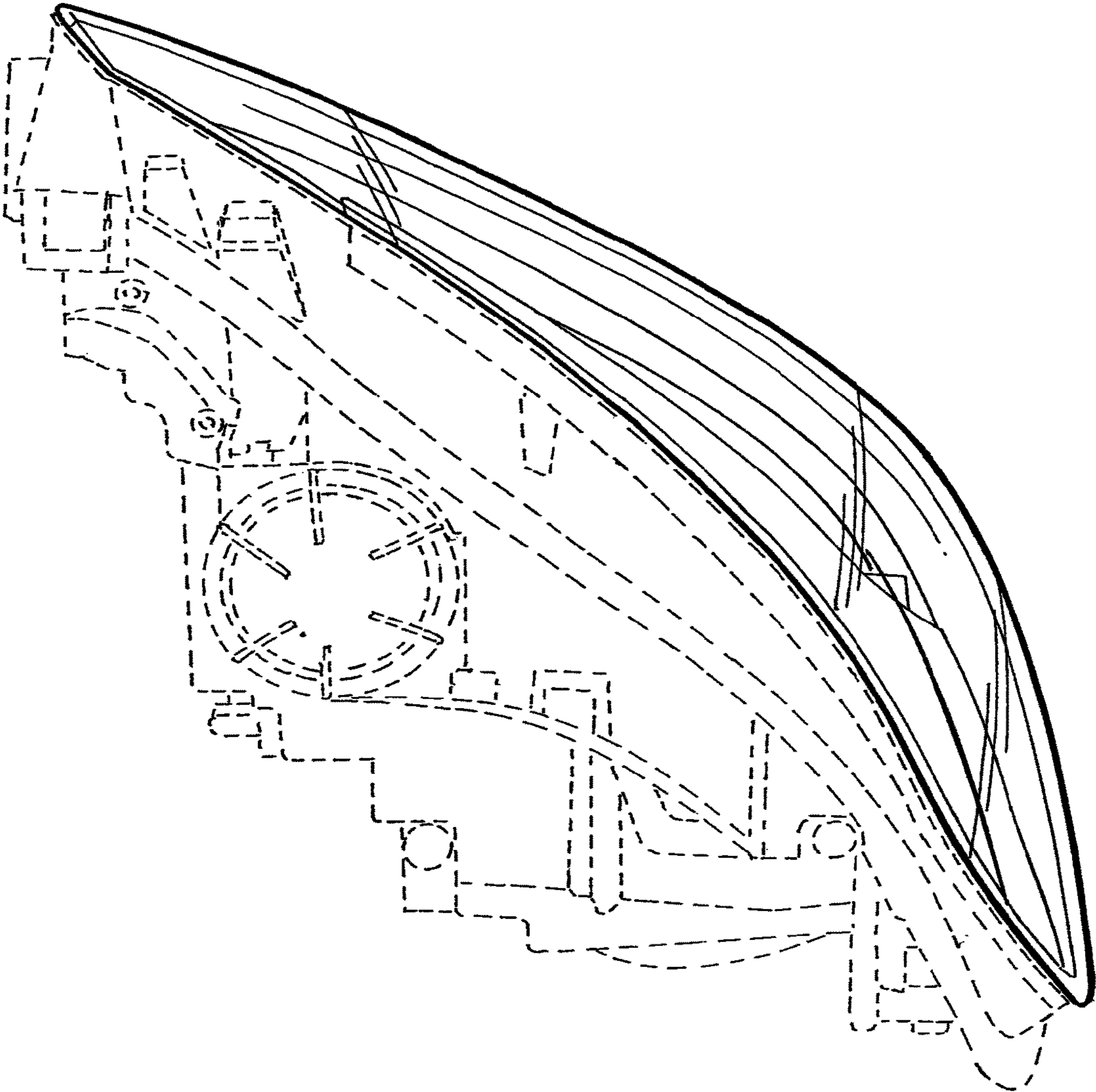

FIG. 10