



US00D667344S

(12) **United States Design Patent**
Matsuno et al.

(10) **Patent No.:** **US D667,344 S**
(45) **Date of Patent:** **** Sep. 18, 2012**

(54) **AUTOMOBILE AND/OR TOY REPLICA THEREOF**

EM 001285431-0001 7/2011
WO DM/070375 9/2008
WO DM/073306 2/2011

(75) Inventors: **Keisuke Matsuno**, Kariya (JP); **Eiji Sakaba**, Kariya (JP)

(73) Assignee: **Toyota Jidosha Kabushiki Kaisha**, Toyota-shi (JP)

(**) Term: **14 Years**

(21) Appl. No.: **29/417,317**

(22) Filed: **Apr. 2, 2012**

Related U.S. Application Data

(62) Division of application No. 29/388,637, filed on Mar. 31, 2011.

(51) **LOC (9) Cl.** **12-08**

(52) **U.S. Cl.** **D12/92**

(58) **Field of Classification Search** D12/86,
D12/90-92; D21/424, 433, 434; 296/181.1,
296/181.5

See application file for complete search history.

(56) **References Cited**

U.S. PATENT DOCUMENTS

D421,934 S	3/2000	Hunter et al.	
D473,824 S	4/2003	Mori	
D476,602 S	7/2003	Yanada et al.	
D501,645 S	2/2005	Hosoda et al.	
D606,901 S	12/2009	Inukai et al.	
D607,379 S *	1/2010	Inukai et al.	D12/92
D612,299 S	3/2010	Ito et al.	
D615,459 S *	5/2010	Miyazaki et al.	D12/92
D626,457 S *	11/2010	Lian et al.	D12/92
D647,431 S *	10/2011	Schell et al.	D12/92

FOREIGN PATENT DOCUMENTS

EM	001605221-0001	9/2010
EM	001004782-0001	10/2010

OTHER PUBLICATIONS

Kia Forte, Mfg. Kia, netcarshow.com, URL: <http://www.netcarshow.com/Kia>; 2010.

Lexus LF-A, Mfg. Toyota, netcarshow.com, URL: <http://www.netcarshow/lexus>, 2009.

Toyota-FT-HS Concept, Mfg. Toyota, netcarshow.com, URL: www.netcarshow.com/Toyota, 2007.

Honda Civic Type R, Mfg. Honda, netcarshow.com, URL: <http://netcarshow.com>, 2007.

Honda Accord Sports Style, Mfg. HONDA, Honda.co.jp, URL: www.honda.co.jp/ACCORD, 2008.

Catalog of Crown, Toyota Crown, Mfg. Toyota, Publisher: Toyota Jidosha Kabushiki Kaisha, Feb. 2008.

Shingata Atenza No Subete, Mazda Atenza, Mfg. Mazda, San-Eu Shibi Publishing Co., Ltd., Mar. 28, 2008.

(Continued)

Primary Examiner — Melody N Brown

(74) *Attorney, Agent, or Firm* — Finnegan, Henderson, Farabow, Garrett & Dunner, LLP

(57) **CLAIM**

The ornamental design for an automobile and/or toy replica thereof, as shown and described.

DESCRIPTION

FIG. 1 is a front left perspective view of an automobile and/or toy replica thereof of our new design;

FIG. 2 is a rear left perspective view thereof;

FIG. 3 is a front view thereof;

FIG. 4 is a rear view thereof;

FIG. 5 is a left side view thereof, the right side view being a mirror image thereof; and,

FIG. 6 is a top plan view thereof.

The broken lines depict environment and the elements depicted in these broken lines form no part of the claimed design. The bottom view forms no part of the claimed design.

1 Claim, 5 Drawing Sheets

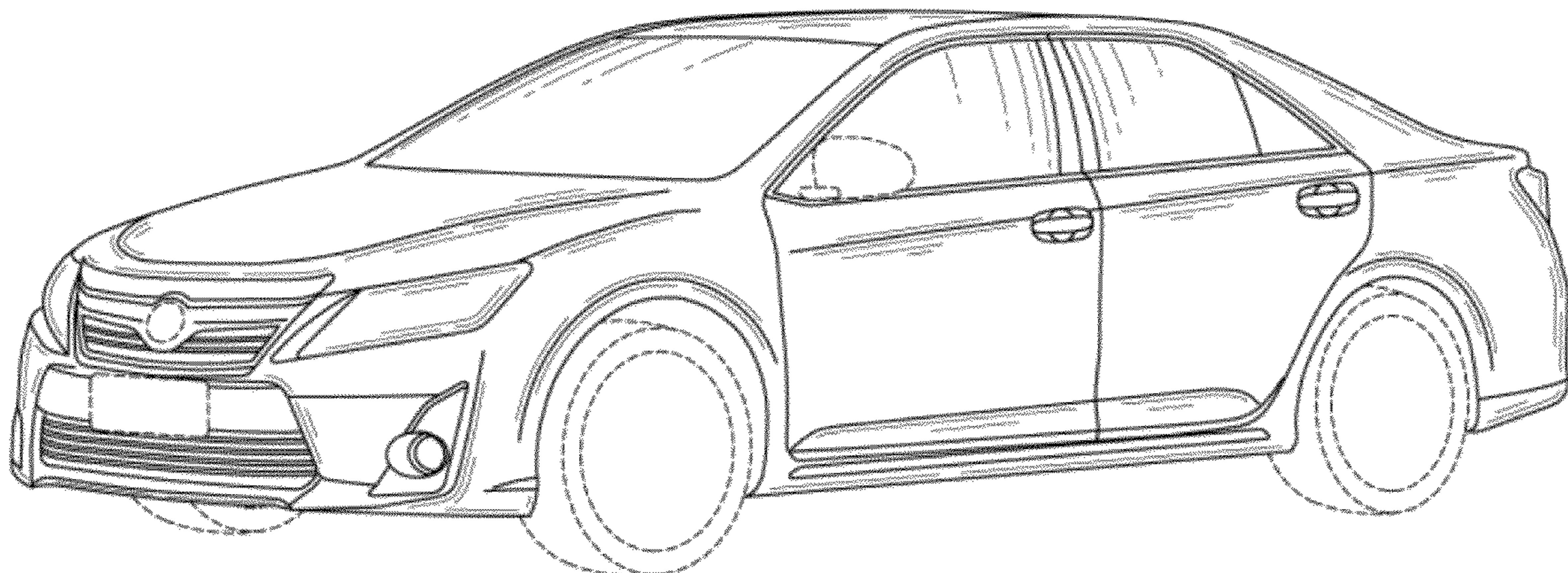

OTHER PUBLICATIONS

Mazda MAZDA6, Mfg. Mazda, netcarshow.com, URL: <http://www.netcarshow.com/mazda>, 2010.

Ford Fusion, Mfg. Ford, netcarshow.com, URL: <http://www.netcarshow.com/ford>, 2009.

Audi TT-RS, Mfg. Audi, netcarshow.com, URL: <http://www.netcarshow.com/audi>, 2010.

Lamborghini Reventon, Mfg. Lamborghini, netcarshow.com, URL: <http://www.netcarshow.com/lamborghini>, 2008.

Mercedes Benz C 63, Mfg. Mercedes Benz; *Za Rulyom Magazine*, No. 12, 2010; pp. 247, 248, 250, front cover.

Mercedes Benz C 63 AMG; Mfg. Mercedes Benz; *Automir Magazine*, No. 15, Apr. 2011; p. 8.

* cited by examiner

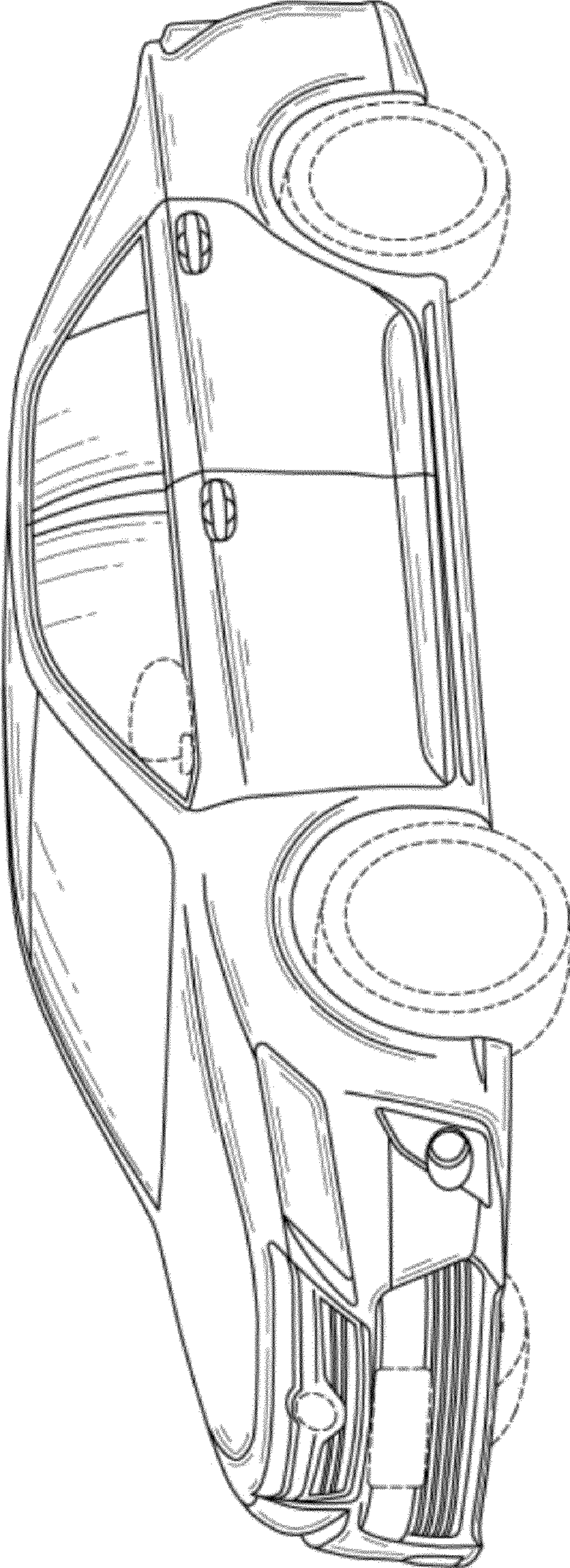

FIG. 1

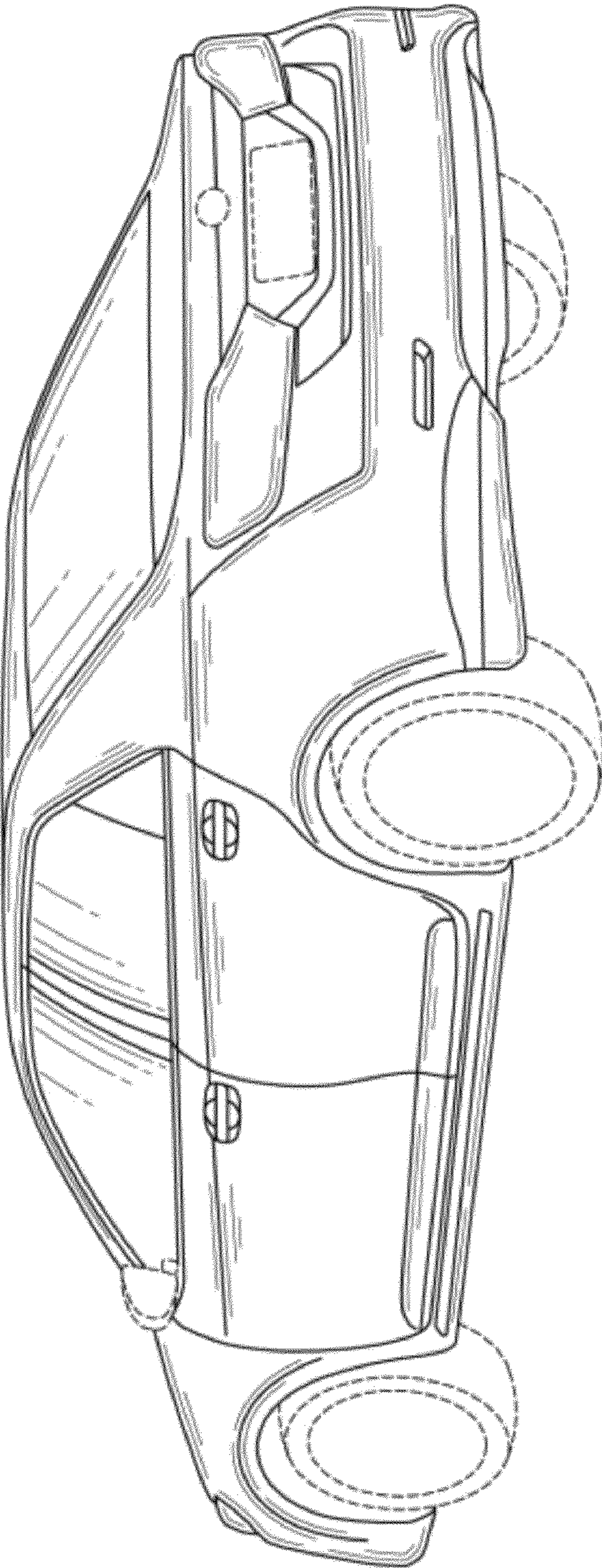

FIG. 2

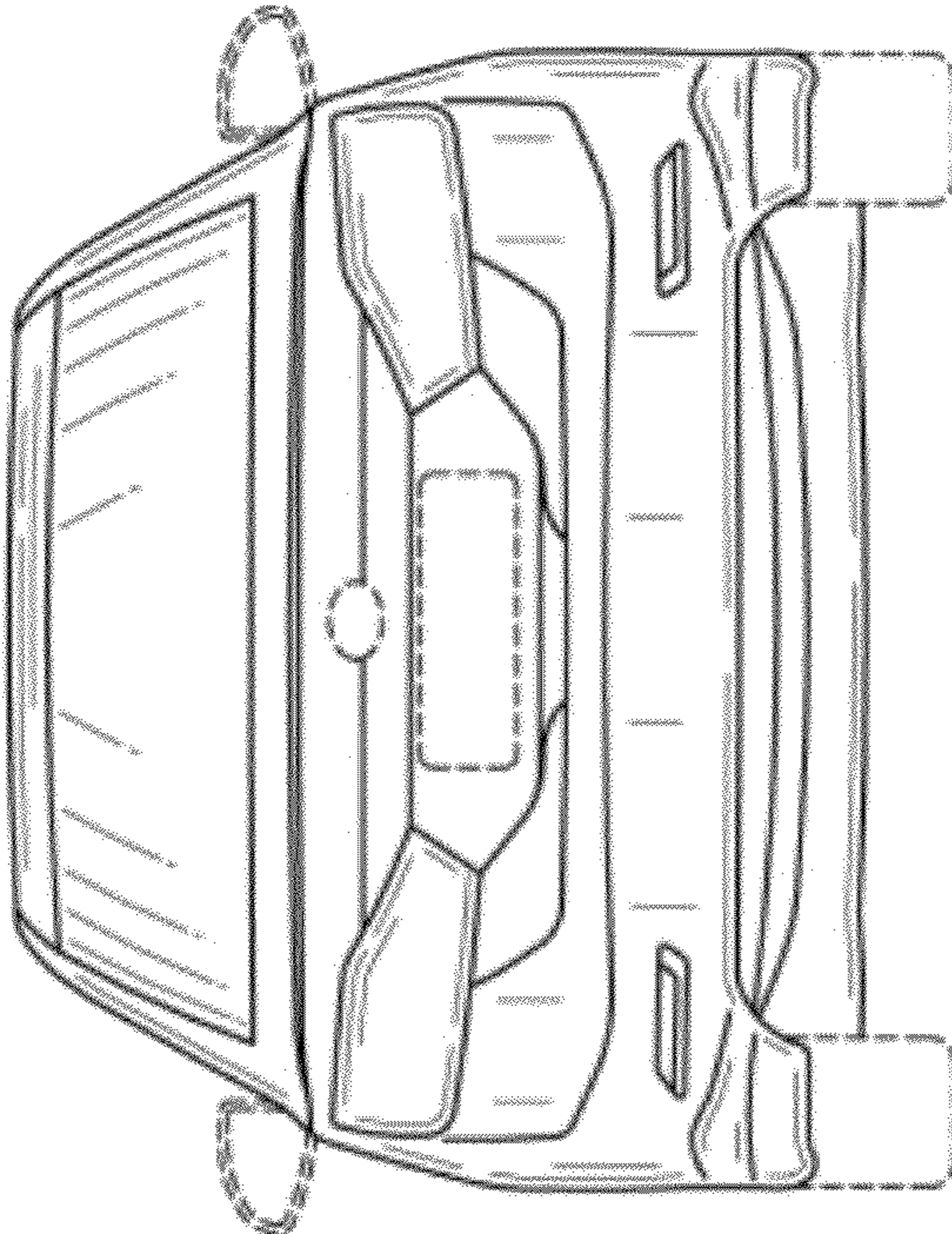

FIG. 4

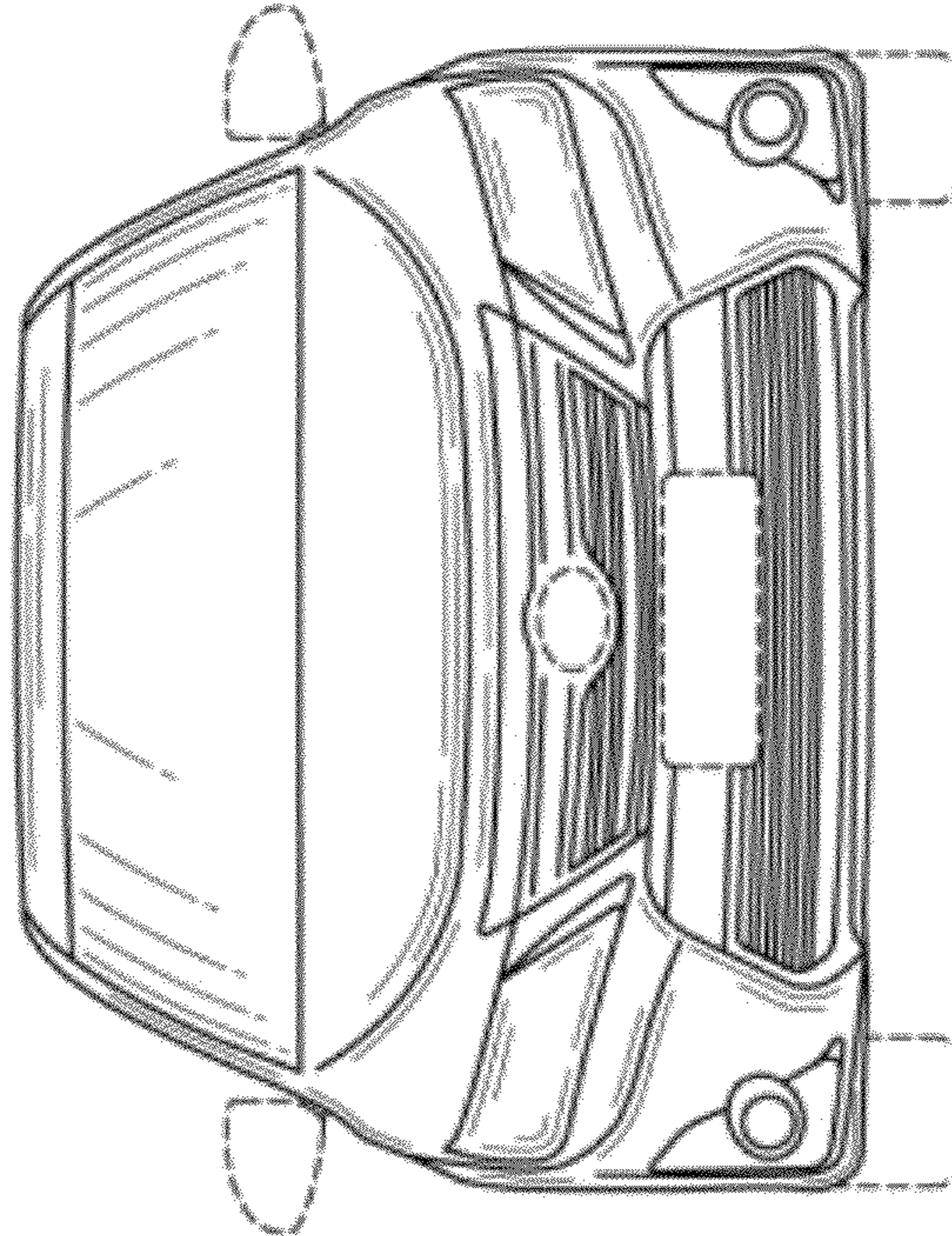

FIG. 3

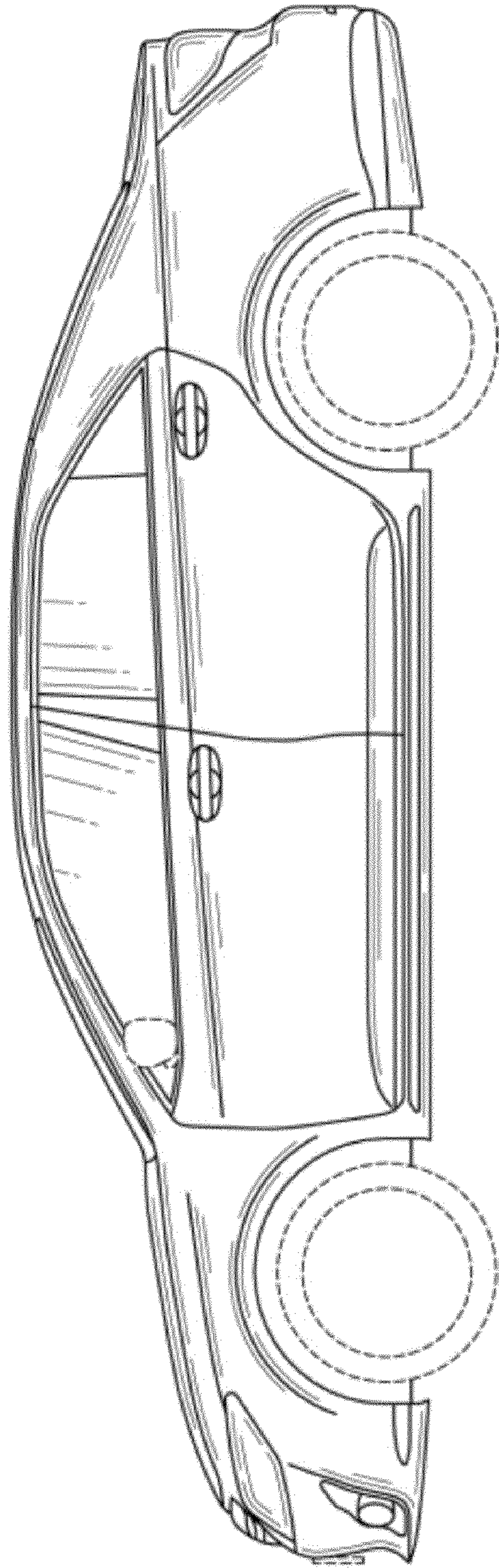

FIG. 5

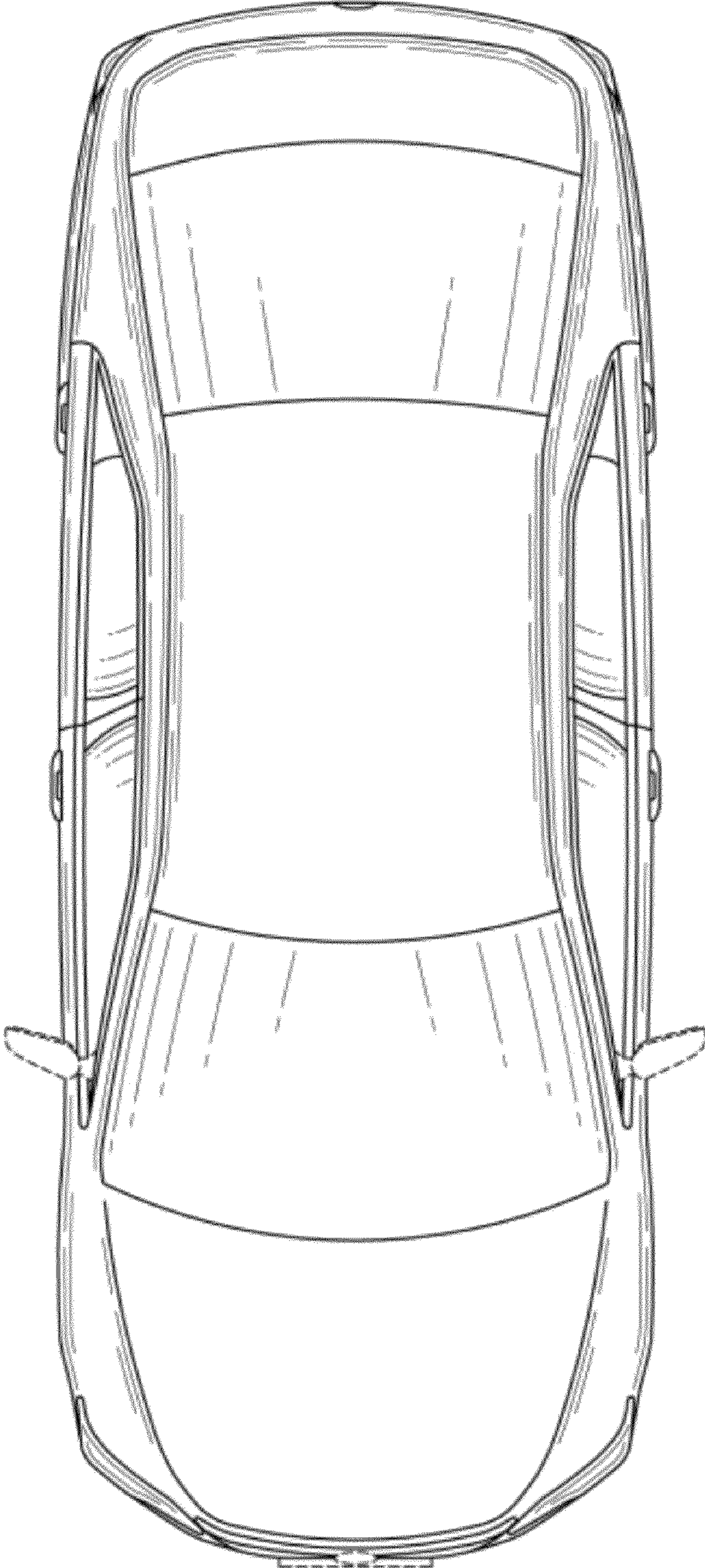

FIG. 6