



US00D667342S

(12) **United States Design Patent**  
**Kobayashi et al.**

(10) **Patent No.:** **US D667,342 S**  
(45) **Date of Patent:** **\*\* Sep. 18, 2012**

(54) **AUTOMOBILE AND/OR TOY REPLICA THEREOF**

(75) Inventors: **Hirotda Kobayashi**, Toyota (JP);  
**Tomonori Matsumoto**, Newport Beach, CA (US)

(73) Assignee: **Toyota Jidosha Kabushiki Kaisha**, Toyota-shi (JP)

(\*\*) Term: **14 Years**

(21) Appl. No.: **29/388,637**

(22) Filed: **Mar. 31, 2011**

(51) **LOC (9) Cl.** ..... **12-08**

(52) **U.S. Cl.** ..... **D12/91**

(58) **Field of Classification Search** ..... D12/86,  
D12/90-92; D21/424, 433, 434; 296/181.1,  
296/181.5

See application file for complete search history.

(56) **References Cited**

**U.S. PATENT DOCUMENTS**

D421,934 S	3/2000	Hunter et al.	
D473,824 S	4/2003	Mori	
D476,602 S	7/2003	Yanada et al.	
D501,645 S	2/2005	Hosoda et al.	
D606,901 S	12/2009	Inukai et al.	
D607,379 S *	1/2010	Inukai et al.	D12/92
D612,299 S	3/2010	Ito et al.	
D615,459 S *	5/2010	Miyazaki et al.	D12/92
D626,457 S *	11/2010	Lian et al.	D12/92
D647,431 S *	10/2011	Schell et al.	D12/92

**FOREIGN PATENT DOCUMENTS**

EM	001605221-0001	9/2010
EM	001004782-0001	10/2010
EM	001285431-0001	7/2011
WO	DM/070375	9/2008
WO	DM/073306	2/2011

**OTHER PUBLICATIONS**

Kia Forte, Mfg. Kia, netcarshow.com, URL: <http://www.netcarshow.com/Kia>; 2010.

Lexus LF-A, Mfg. Toyota, netcarshow.com, URL: <http://www.netcarshow/lexus>, 2009.

Toyota-FT-HS Concept, Mfg. Toyota, netcarshow.com, URL: [www.netcarshow.com/Toyota](http://www.netcarshow.com/Toyota), 2007.

Honda Civic Type R, Mfg. Honda, netcarshow.com, URL: <http://netcarshow.com>, 2007.

Honda Accord Sports Style, Mfg. Hondam, Honda.co.jp, URL: [www.honda.co.jp/ACCORD](http://www.honda.co.jp/ACCORD), 2008.

Catalog of Crown, Toyota Crown, Mfg. Toyota, Publisher: Toyota Jidosha Kabushiki Kaisha, Feb. 2008.

Shingata Atenza No Subete, Mazda Atenza, Mfg. Mazda, San-Eu Shibi Publishing Co., Ltd., Mar. 28, 2008.

Mazda Mazda6, Mfg. Mazda, netcarshow.com, URL: <http://www.netcarshow.com/mazda>, 2010.

Ford Fusion, Mfg. Ford, netcarshow.com, URL: <http://www.netcarshow.com/ford>, 2009.

Audi TT-RS, Mfg. Audi, netcarshow.com, URL: <http://www.netcarshow.com/audi>, 2010.

Lamborghini Reventon, Mfg. Lamborghini, netcarshow.com, URL: <http://www.netcarshow.com/lamborghini>, 2008.

(Continued)

*Primary Examiner* — Melody N Brown

(74) *Attorney, Agent, or Firm* — Finnegan, Henderson, Farabow, Garrett & Dunner, LLP

(57) **CLAIM**

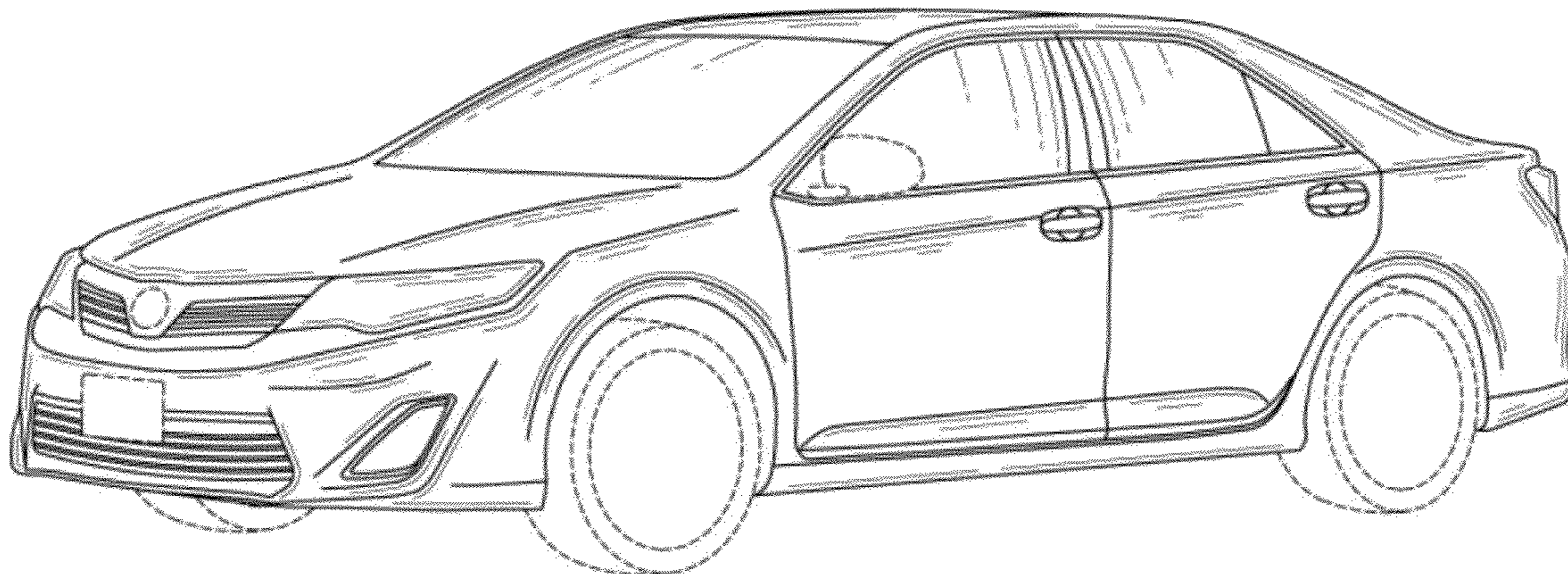
The ornamental design for an automobile and/or toy replica thereof, as shown and described.

**DESCRIPTION**

FIG. 1 is a left front perspective view of an automobile and/or a toy replica thereof of our new design; FIG. 2 is a left, rear perspective view thereof; FIG. 3 is a front elevation view thereof; FIG. 4 is a rear elevation view thereof; FIG. 5 is a left side elevation view thereof, the right side elevation view being a mirror image; and, FIG. 6 is a top plan view thereof.

The broken lines in the drawings depict environment and the elements in broken lines form no part of the claimed design.

**1 Claim, 5 Drawing Sheets**



# US D667,342 S

Page 2

---

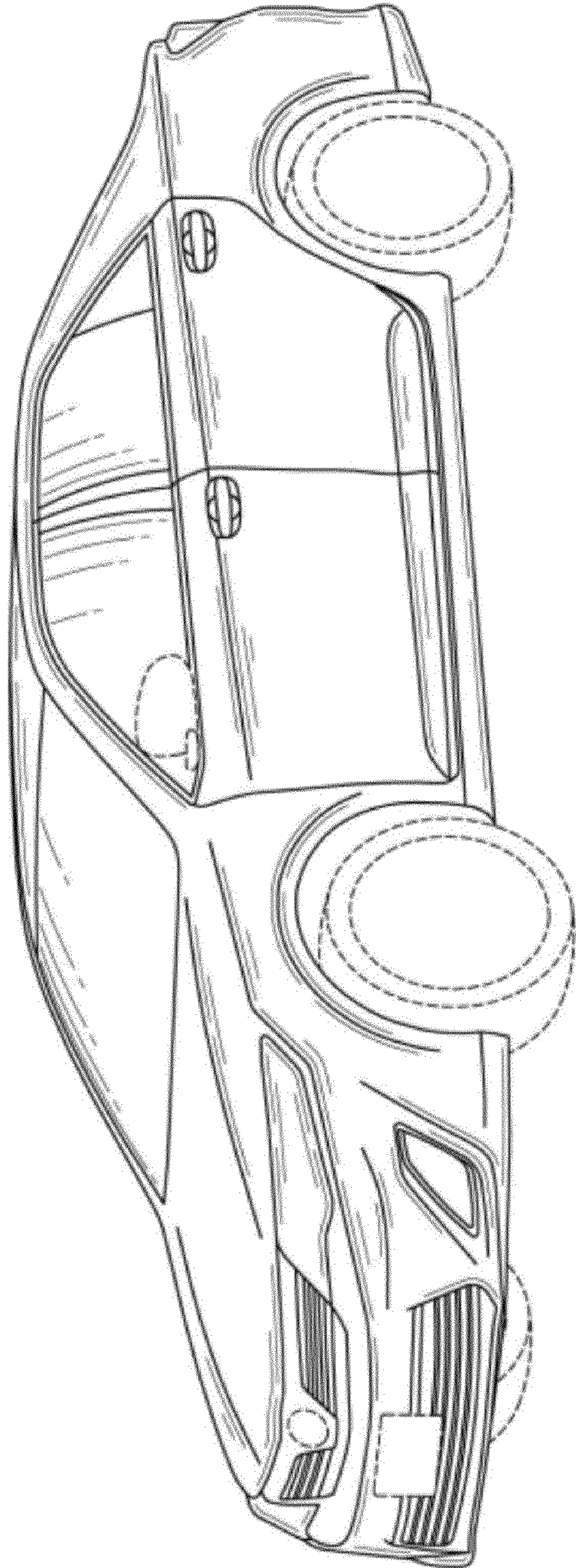
## OTHER PUBLICATIONS

Mercedes Benz C 63, Mfg. Mercedes Benz; *Za Rulyom Magazine*, No. 12, 2010; pp. 247, 248, 250, front cover.

Mercedes Benz C 63 AMG; Mfg. Mercedes Benz; *Automir Magazine*, No. 15, Apr. 2011; p. 8.

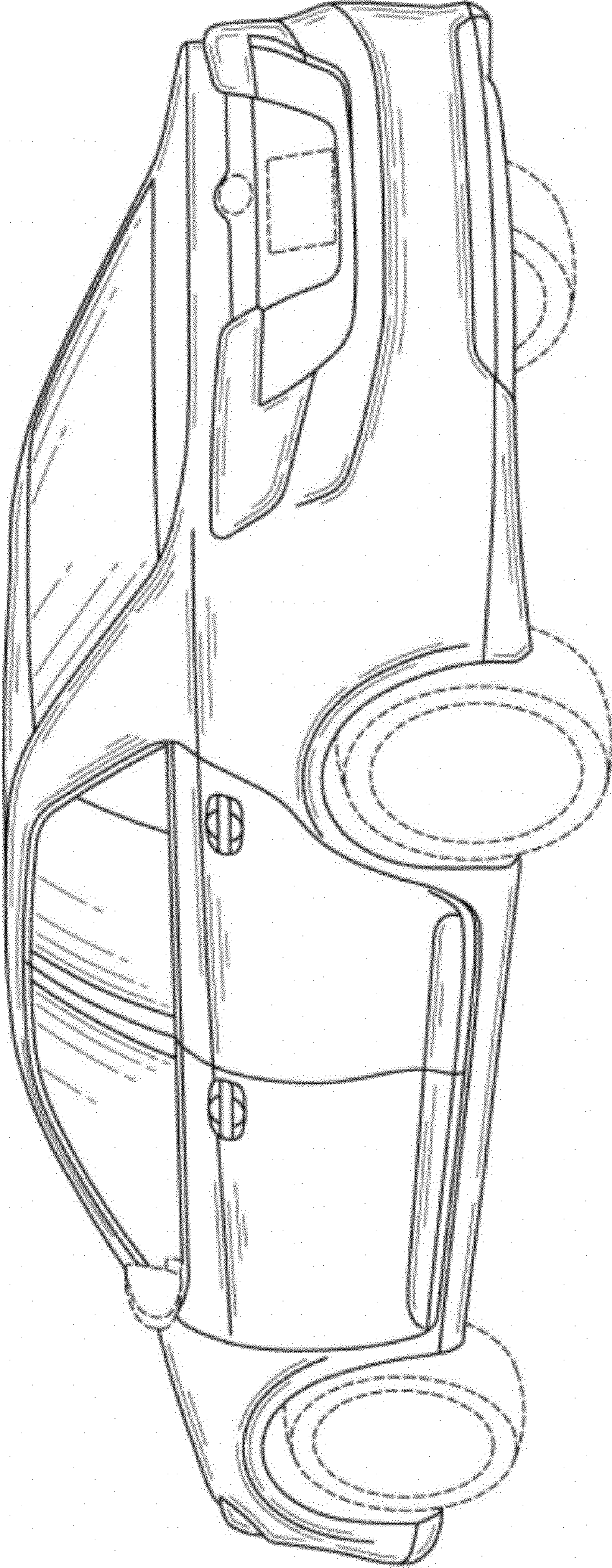
\* cited by examiner





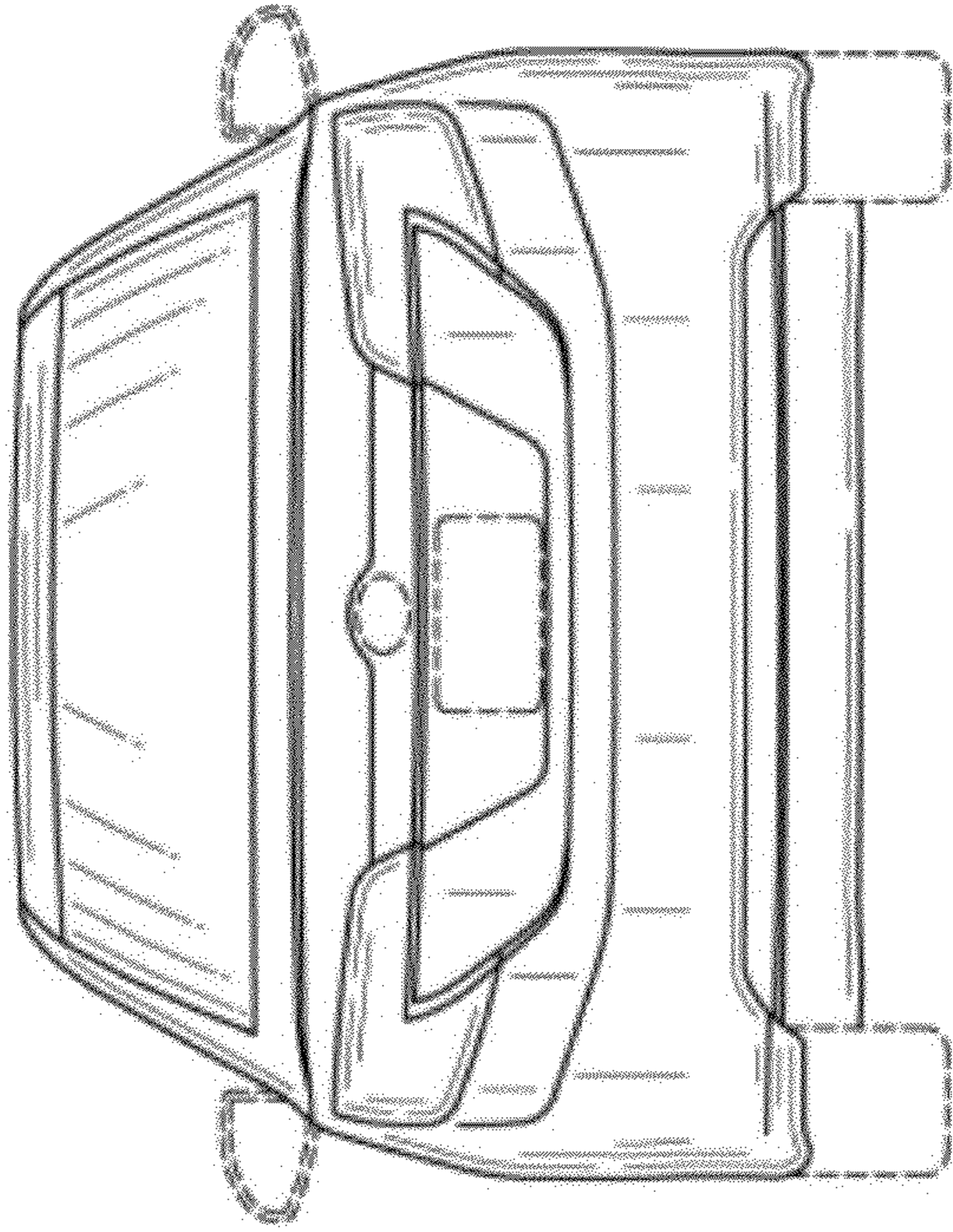
**FIG. 1**



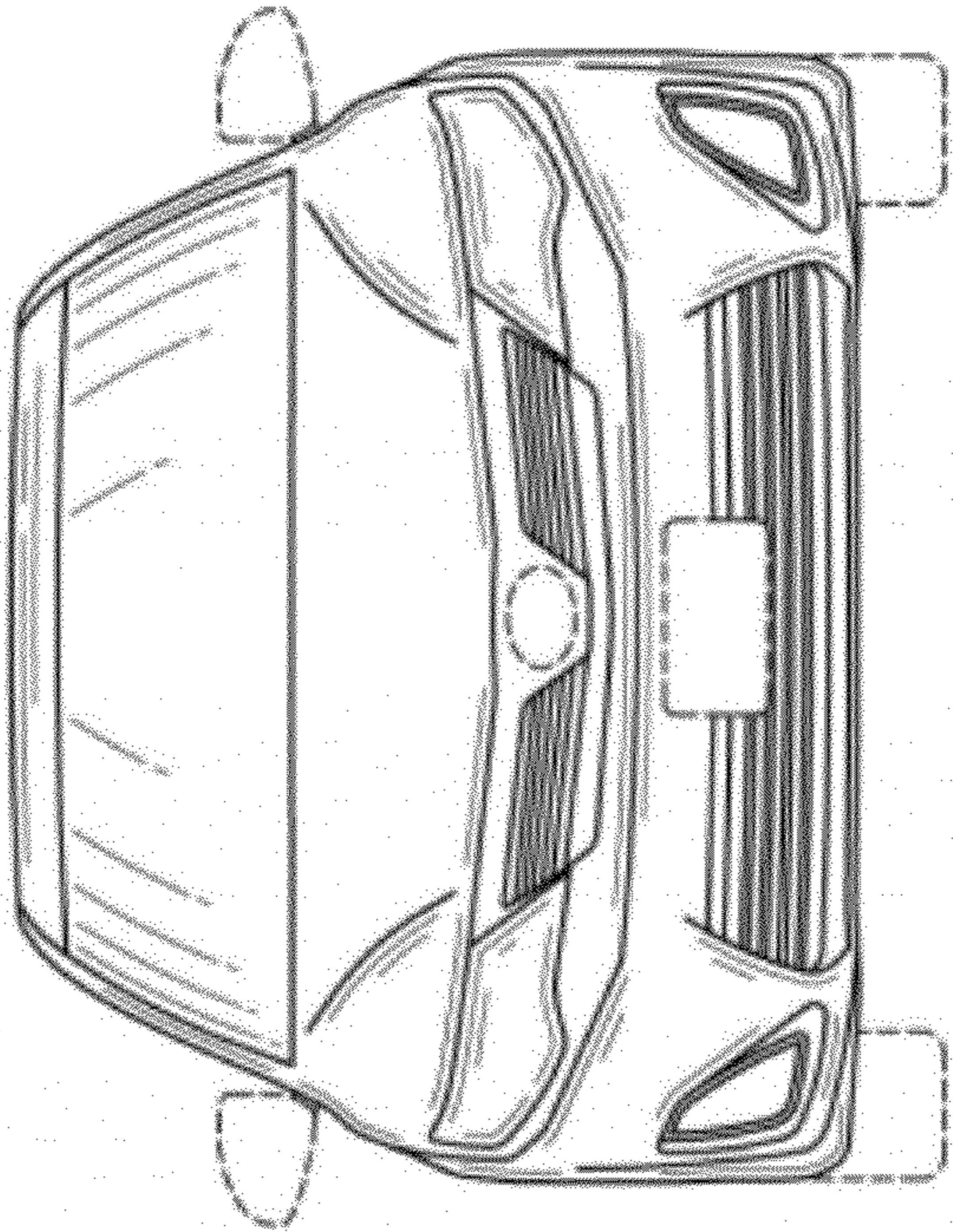


**FIG. 2**



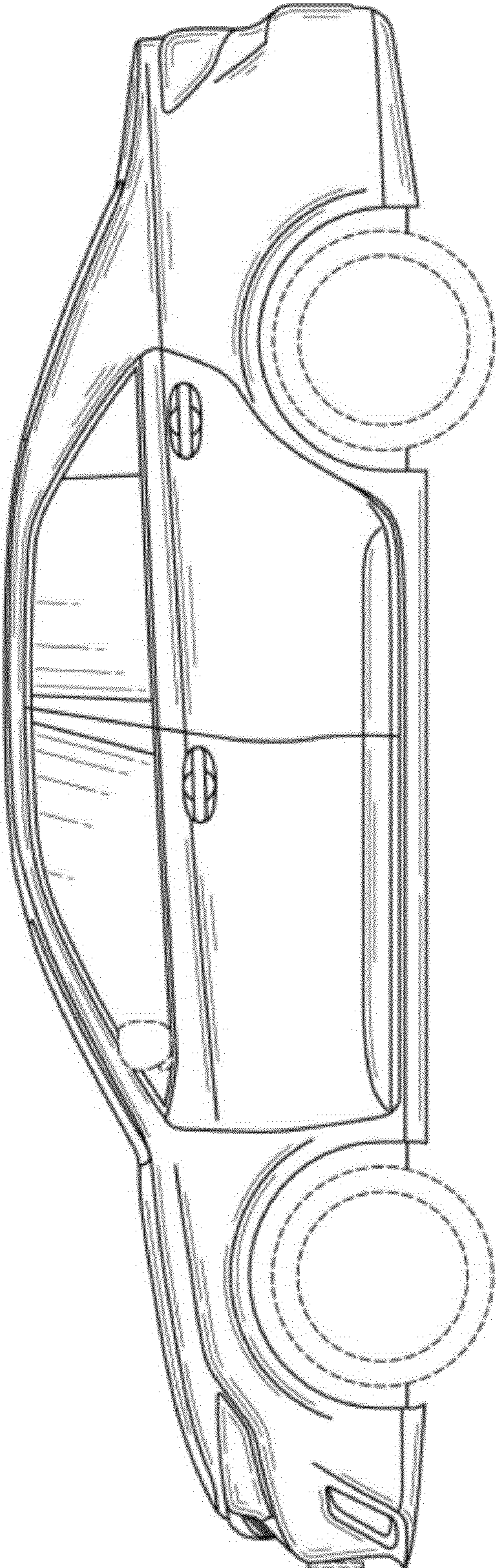


**FIG. 4**



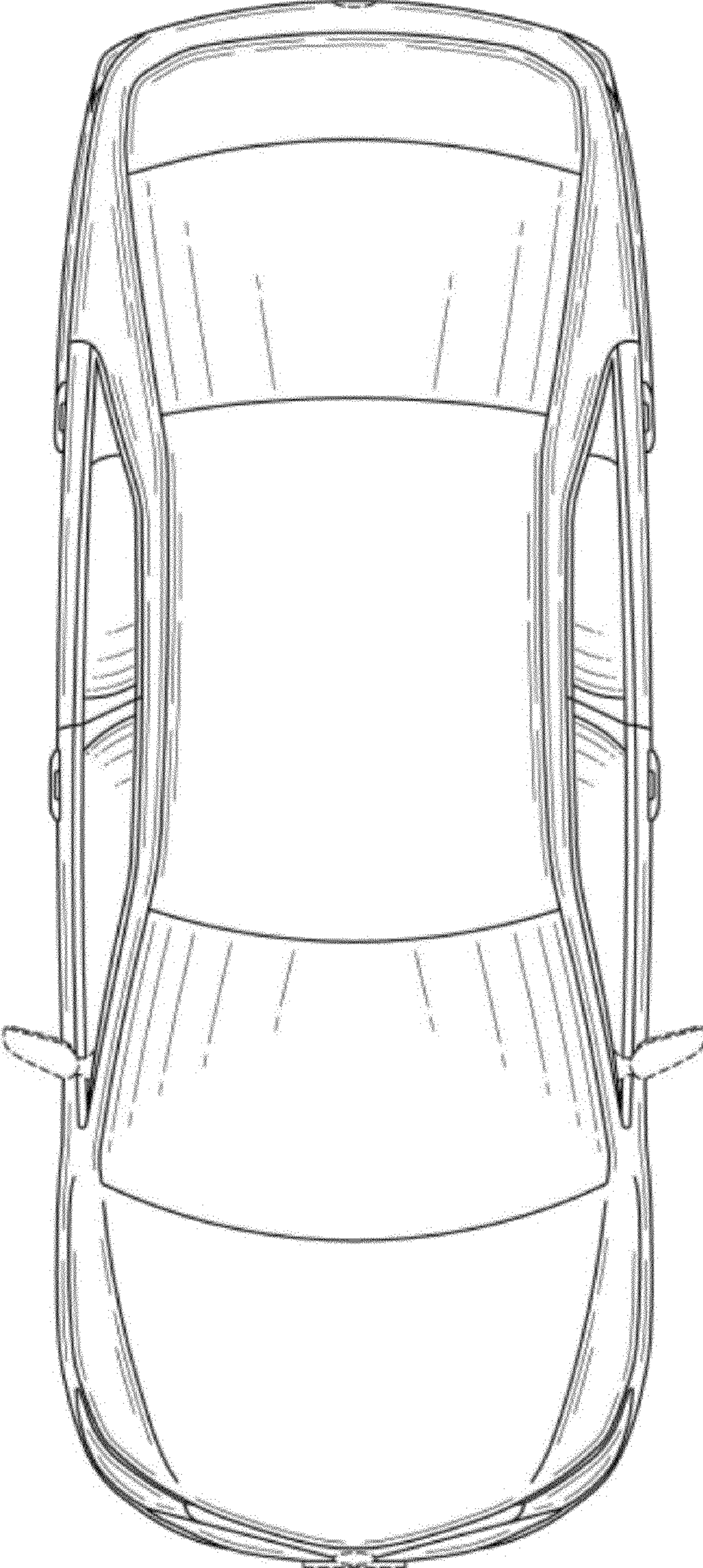
**FIG. 3**





**FIG. 5**





**FIG. 6**