



US00D667282S

(12) **United States Design Patent**  
**Evans**

(10) **Patent No.:** **US D667,282 S**

(45) **Date of Patent:** **\*\* Sep. 18, 2012**

(54) **STAKE HOLE MAKER**

(76) Inventor: **Donald L. Evans**, Reno, NV (US)

(\*\*) Term: **14 Years**

(21) Appl. No.: **29/395,456**

(22) Filed: **Jan. 26, 2012**

(51) **LOC (9) Cl.** ..... **08-01**

(52) **U.S. Cl.** ..... **D8/1**

(58) **Field of Classification Search** ..... D8/1; D21/840;  
47/43-47; 135/118; 248/156

See application file for complete search history.

(56) **References Cited**

**U.S. PATENT DOCUMENTS**

D292,060	S	*	9/1987	Kerber	.....	D21/840
D292,475	S	*	10/1987	Kitchen	.....	D8/1
4,831,798	A	*	5/1989	Otteson	.....	52/153
D338,600	S	*	8/1993	Baezzo	.....	D8/1
5,665,008	A	*	9/1997	Chaney	.....	473/271
D389,705	S	*	1/1998	Puett	.....	D8/1
D408,232	S	*	4/1999	Liu	.....	D8/1
D420,260	S	*	2/2000	Tseng	.....	D8/1
D433,292	S	*	11/2000	Giannoni	.....	D8/1
D466,379	S	*	12/2002	Barbi et al.	.....	D8/1
D466,765	S	*	12/2002	Barbi et al.	.....	D8/1
6,575,417	B1	*	6/2003	Krommenakker	.....	248/311.2
D577,966	S	*	10/2008	Cosimo	.....	D8/1
D652,698	S	*	1/2012	Rothell	.....	D8/1
D655,584	S	*	3/2012	Katzin	.....	D8/1
D657,639	S	*	4/2012	Yates, Jr.	.....	D8/1

\* cited by examiner

*Primary Examiner* — Sheryl Lane

(74) *Attorney, Agent, or Firm* — George W. Wasson

(57) **CLAIM**

The ornamental design for a stake hole maker, as shown and described.

**DESCRIPTION**

FIG. 1 is a side elevation view of the two part stake hole maker comprising a KEY member and a hole maker member shown in side-by-side relationship.

FIG. 2 is a front elevation view of the two part stake hole maker illustrating the KEY member and the hole maker member shown in side-by-side relationship.

FIG. 3 is a rear elevation view of the two part stake hole maker illustrating the KEY member and the hole maker member shown in side-by-side relationship.

FIG. 4 is a top plan view of the two part stake hole maker illustrating the KEY member and the hole maker member shown in side-by-side relationship.

FIG. 5 is a bottom plan view of the two part stake hole maker illustrating the KEY member and the hole maker member shown in side-by-side relationship;

FIG. 6 is an isometric view of the two part stake hole maker illustrating the cooperating relationship of the KEY member and the hole maker member in separated side-by-side relationship; and,

FIG. 7 is an environmental perspective view of the two part stake hole maker with the KEY member cooperating with the hole maker member when used in driving the hole maker member into a surface where a hole is to be made and, in phantom, illustrating a mechanism for extracting the hole maker member from the surface after a stake hole has been created.

The broken line showing in FIG. 7 is included for the purpose of illustrating environmental structure and forms no part of the claimed design.

The stake hole maker is shown separated for ease of illustration in FIGS. 1-6.

**1 Claim, 5 Drawing Sheets**

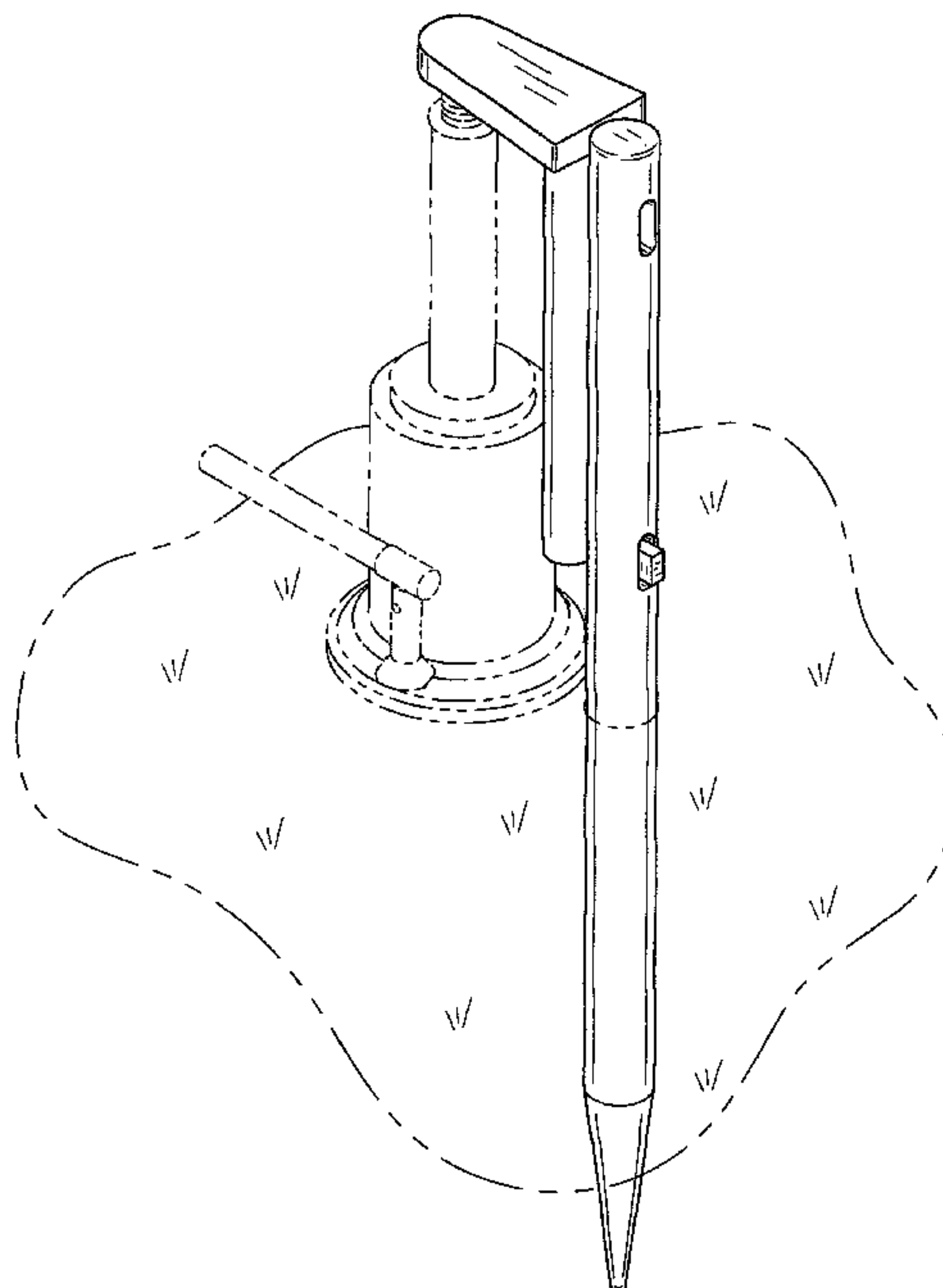
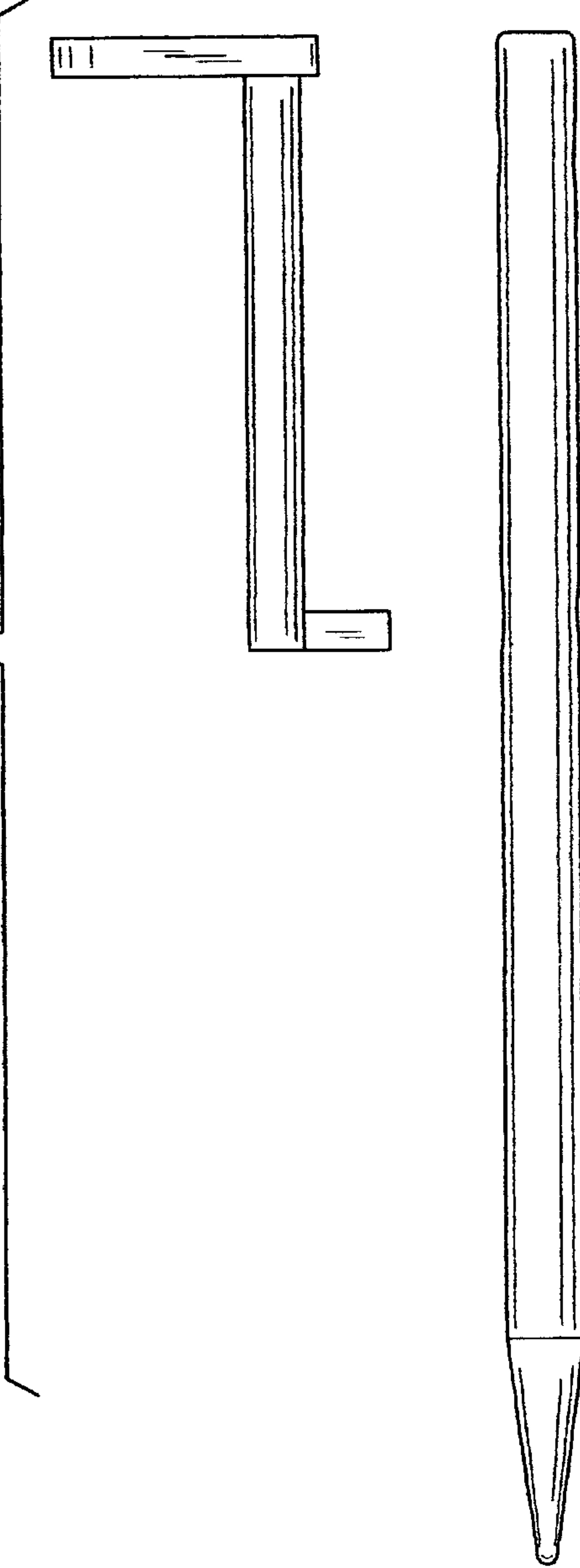

FIG. 1



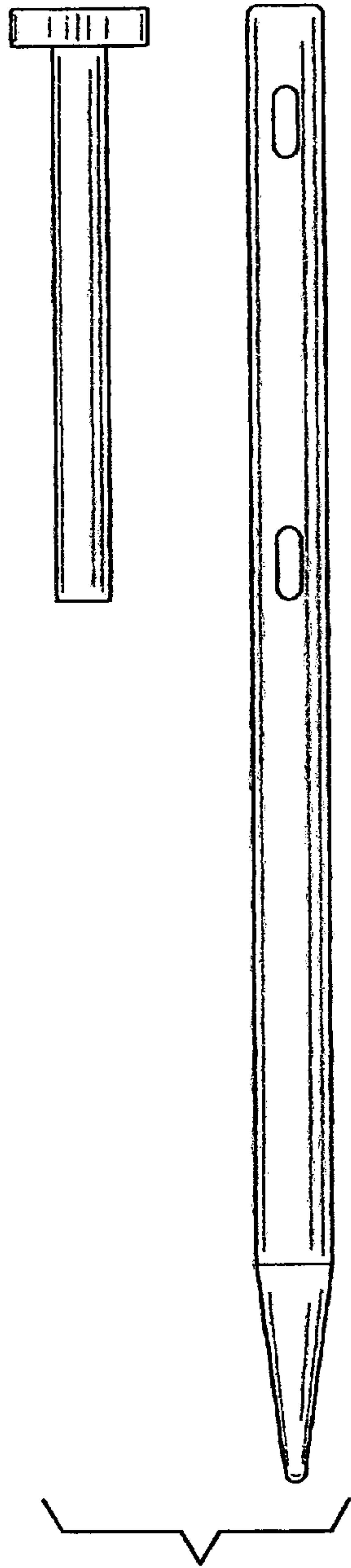

FIG. 2

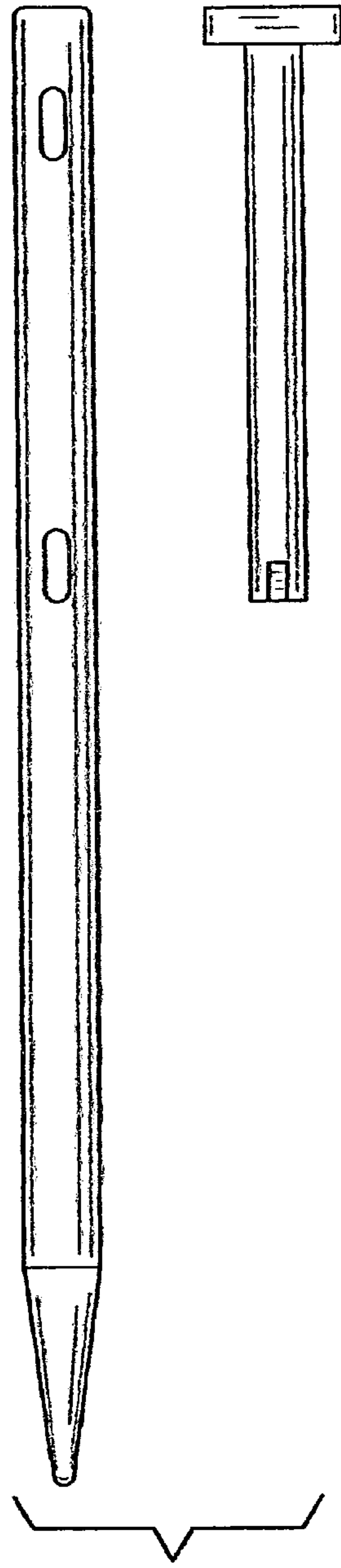

FIG. 3

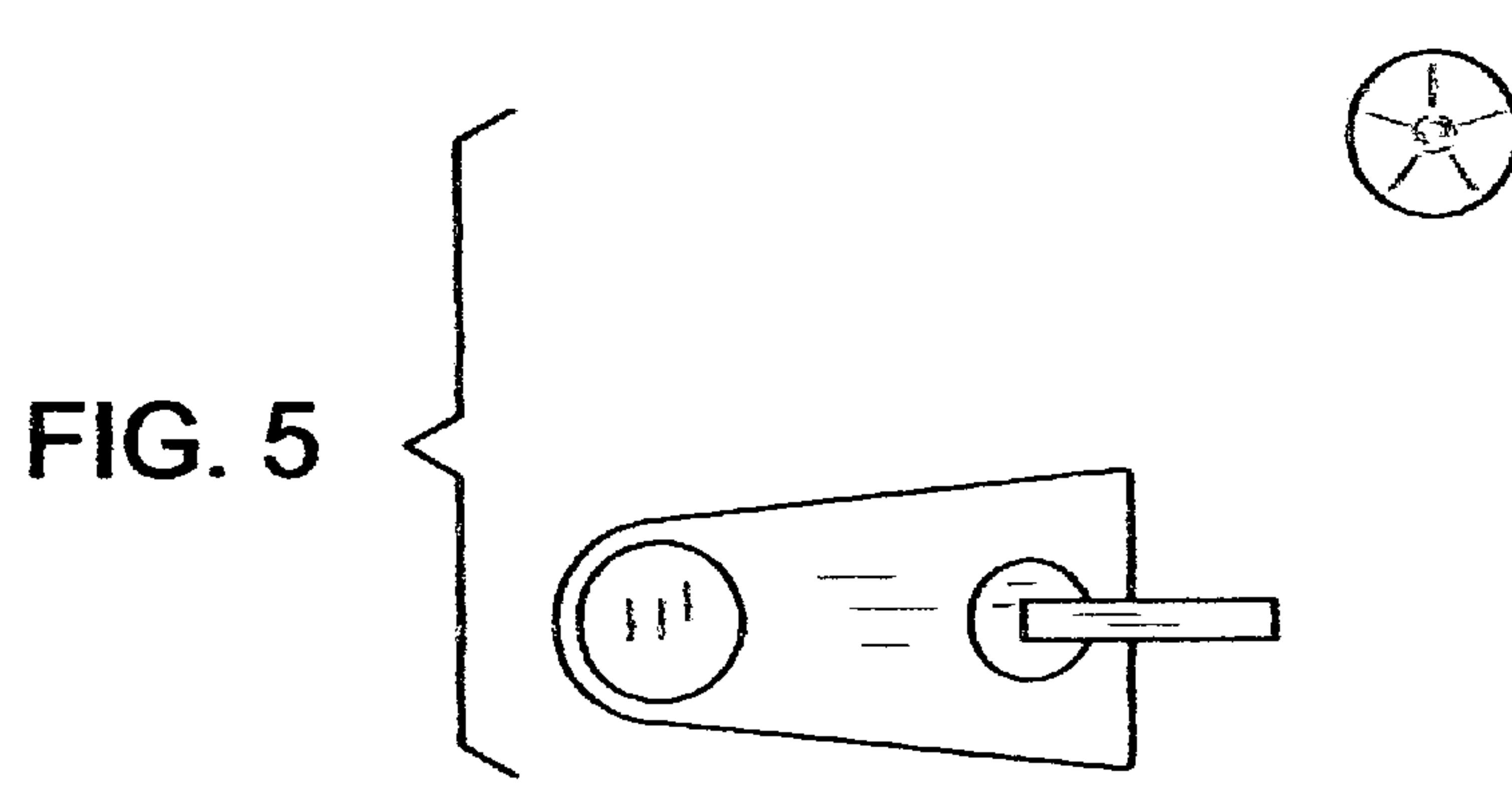
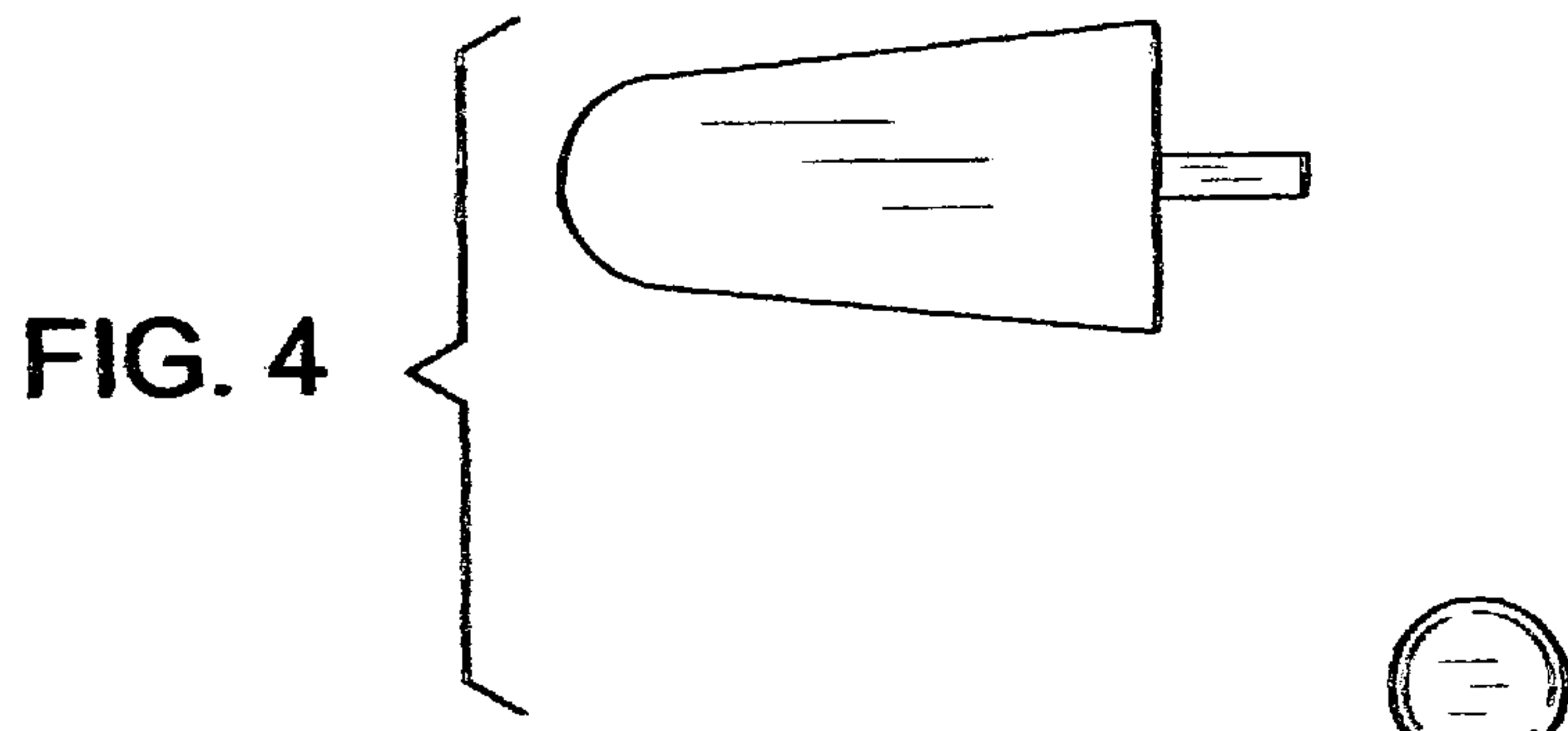
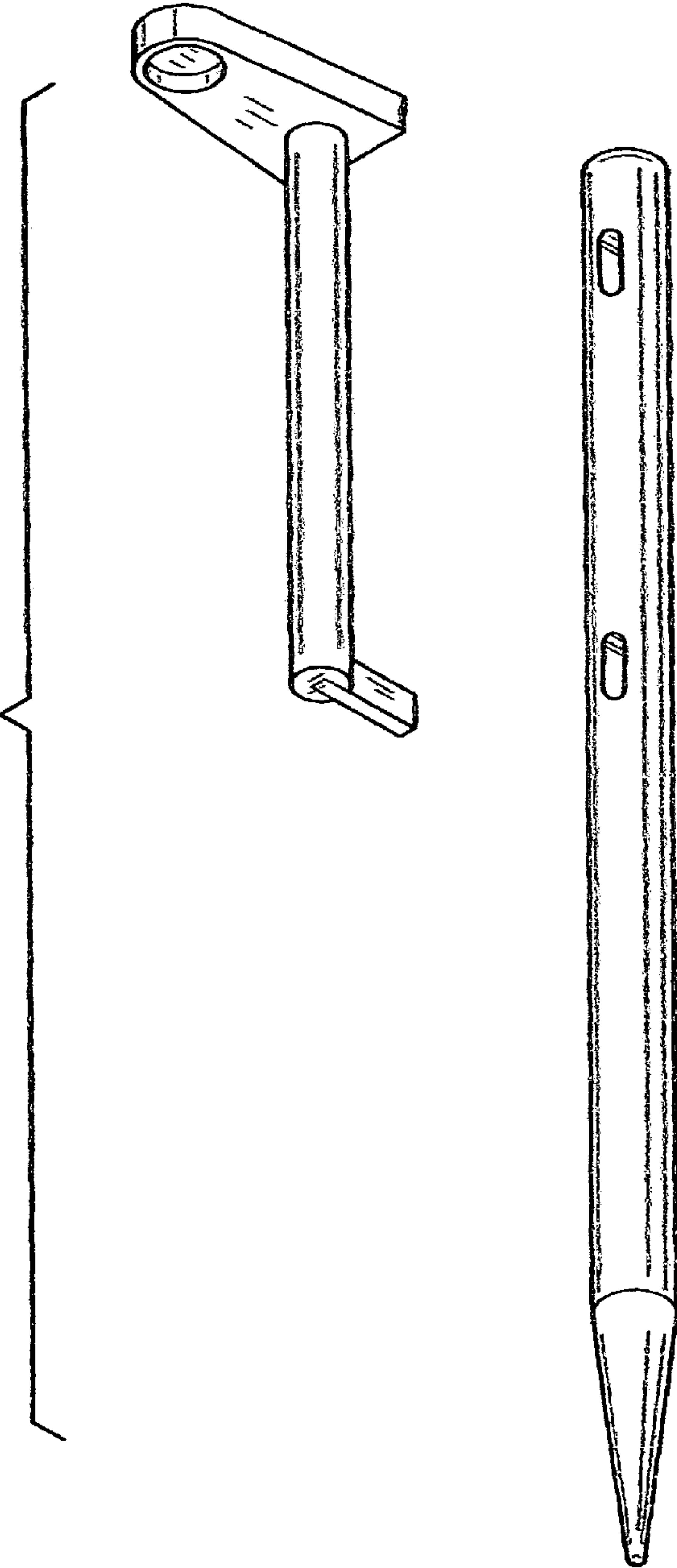

FIG. 6



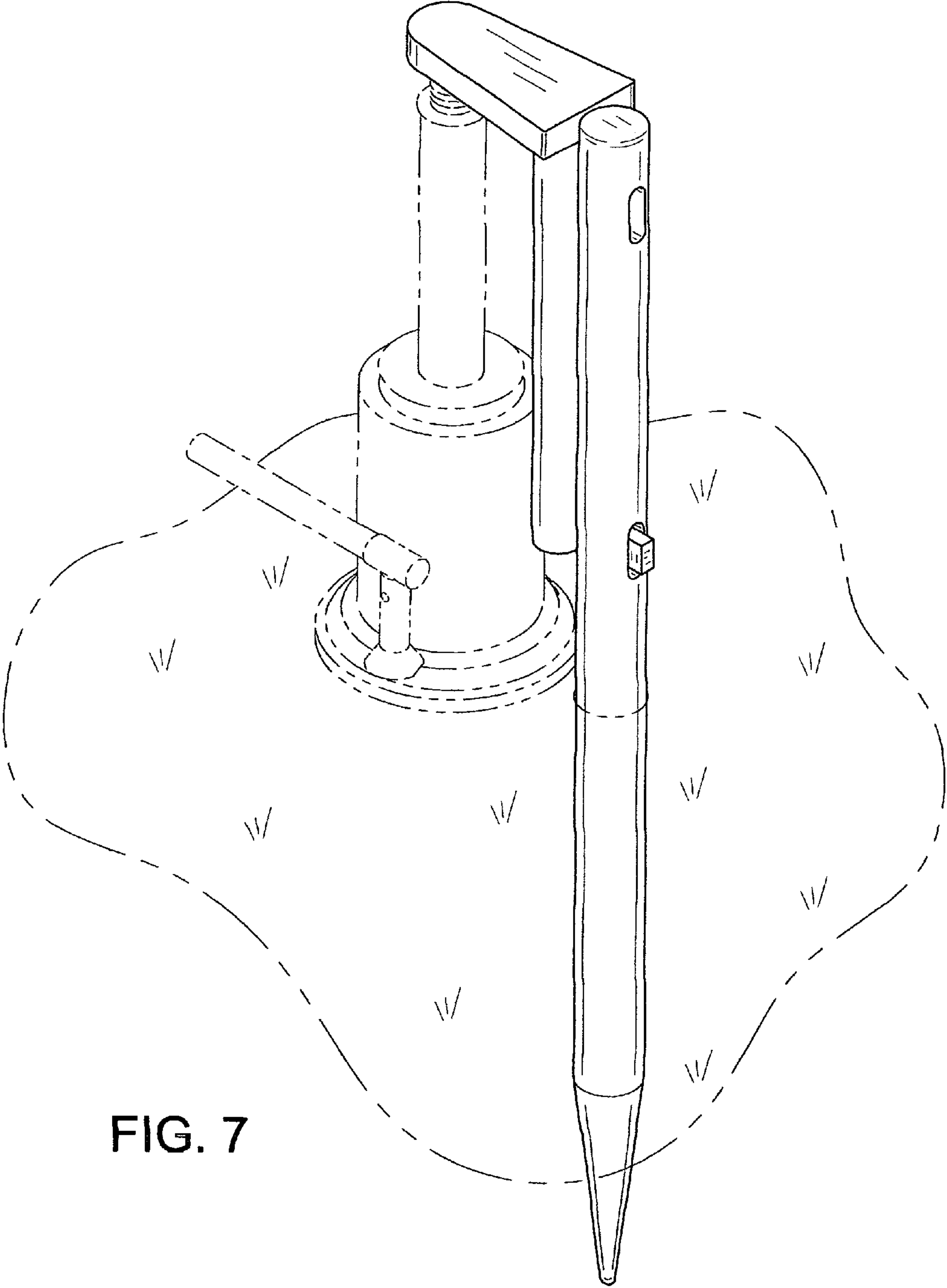

FIG. 7