



US00D667194S

(12) **United States Design Patent**  
**Ryan et al.**

(10) **Patent No.:** **US D667,194 S**  
(45) **Date of Patent:** **\*\* Sep. 11, 2012**

(54) **HAND TRUCK**

(75) Inventors: **Paul Ryan**, Wichita, KS (US); **Robert A. Wood**, Lincoln, NE (US)

(73) Assignee: **DG Manufacturing, LLC**, Wichita, KS (US)

(\*\*) Term: **14 Years**

(21) Appl. No.: **29/402,863**

(22) Filed: **Sep. 28, 2011**

(51) **LOC (9) Cl.** ..... **12-02**

(52) **U.S. Cl.** ..... **D34/26**

(58) **Field of Classification Search** ..... D34/12-27;  
280/47.18, 47.19, 47.2, 47.27, 47.28, 79.1,  
280/79.2, 79.3, 47.26

See application file for complete search history.

(56) **References Cited**

**U.S. PATENT DOCUMENTS**

D336,710	S	*	6/1993	Kinnaman	.....	D34/26
D644,396	S	*	8/2011	Dechant et al.	.....	D34/26
D644,397	S	*	8/2011	Wood et al.	.....	D34/26
D644,400	S	*	8/2011	Wood et al.	.....	D34/26
D644,401	S	*	8/2011	Dechant et al.	.....	D34/26
D654,241	S	*	2/2012	Vilkomirski et al.	.....	D34/26
D661,860	S	*	6/2012	Ryan et al.	.....	D34/26
2005/0087943	A1	*	4/2005	Babkes et al.	.....	280/30

\* cited by examiner

*Primary Examiner* — Cynthia Ramirez

(74) *Attorney, Agent, or Firm* — Brient Intellectual Property Law, LLC

(57) **CLAIM**

The ornamental design for a hand truck, as shown and described.

**DESCRIPTION**

FIG. 1 is a perspective view of a hand truck according to an embodiment of the present design in a first orientation with a handle, a pair of wheels, a pair of castors, a plurality of ribs, various openings, and various fasteners shown in broken lines.

FIG. 2 is a front elevation view of the hand truck of FIG. 1.

FIG. 3 is a rear elevation view of the hand truck of FIG. 1.

FIG. 4 is a left side elevation view of the hand truck of FIG. 1.

FIG. 5 is a right side elevation view of the hand truck of FIG. 1.

FIG. 6 is a top plan view of the hand truck of FIG. 1.

FIG. 7 is a bottom plan view of the hand truck of FIG. 1.

FIG. 8 is a perspective view of the hand truck of FIG. 1 in a second orientation with a handle, a pair of wheels, a pair of castors, a plurality of ribs, various openings, and various fasteners shown in broken lines.

FIG. 9 is a front elevation view of the hand truck of FIG. 8.

FIG. 10 is a rear elevation view of the hand truck of FIG. 8.

FIG. 11 is a left side elevation view of the hand truck of FIG. 8.

FIG. 12 is a right side elevation view of the hand truck of FIG. 8.

FIG. 13 is a top plan view of the hand truck of FIG. 8; and, FIG. 14 is a bottom plan view of the hand truck of FIG. 8.

The broken lines shown in FIGS. 1 through 14 illustrate portions of the hand truck that form no part of the claimed design.

**1 Claim, 13 Drawing Sheets**

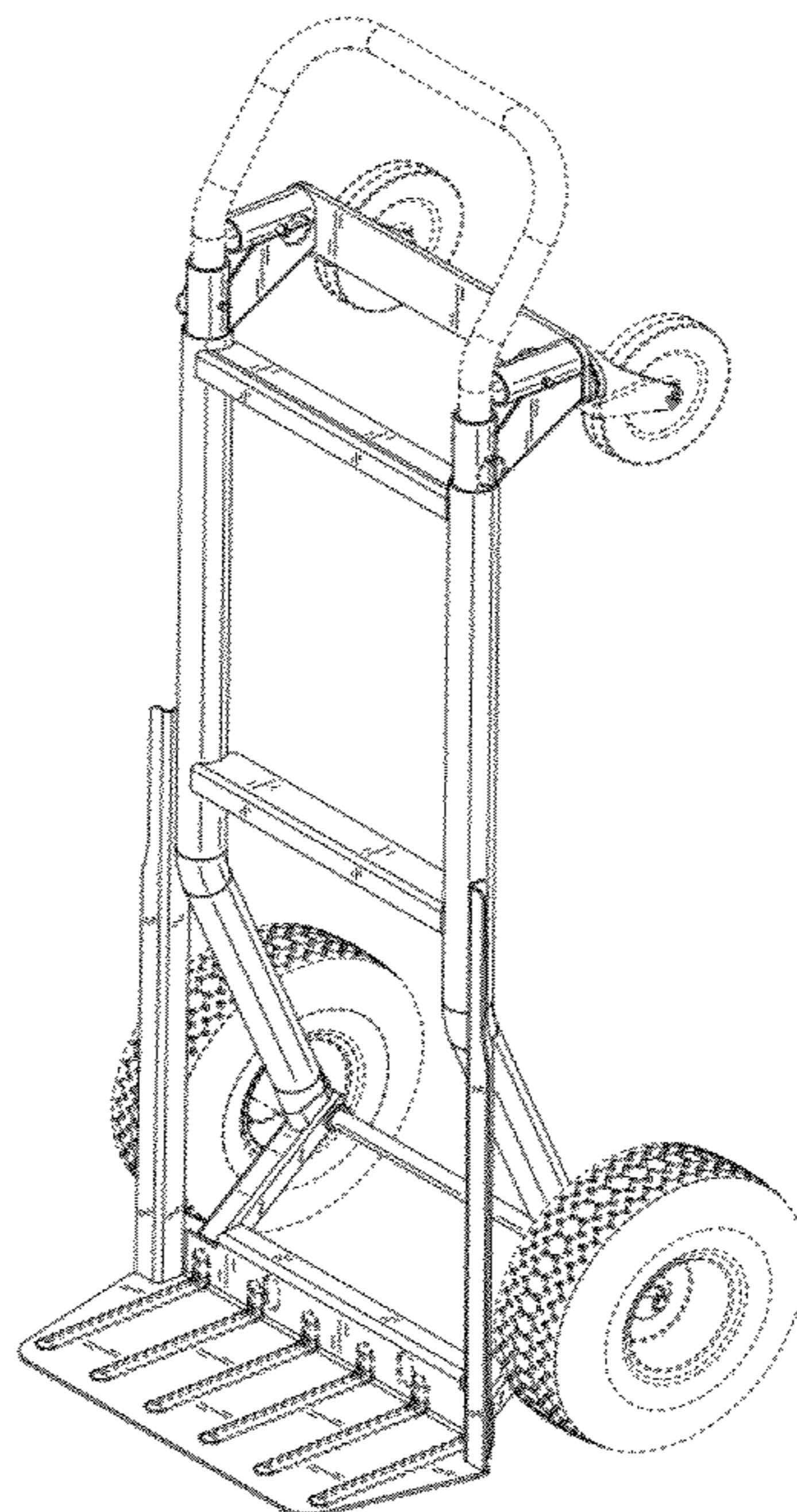

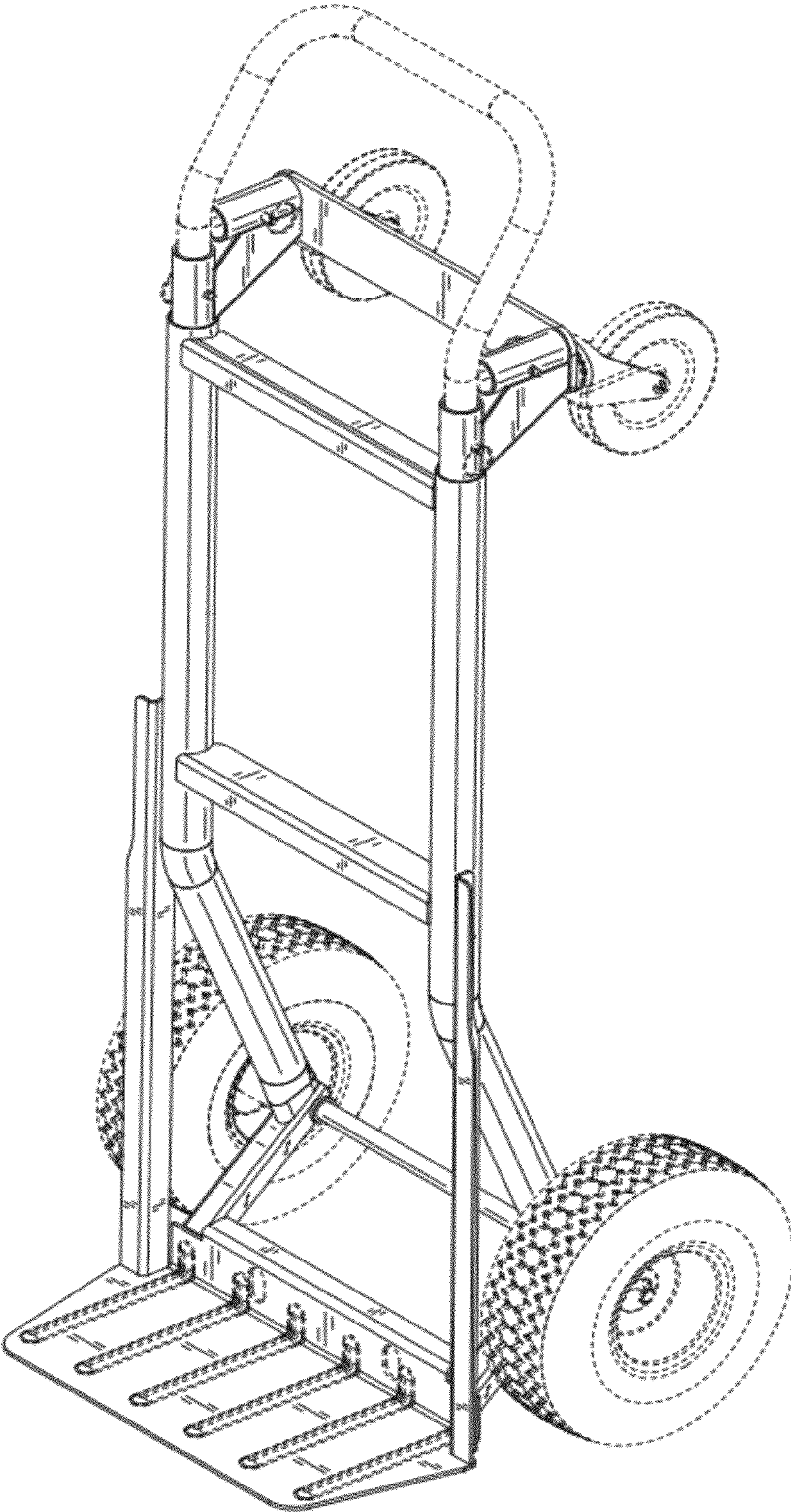

FIG. 1

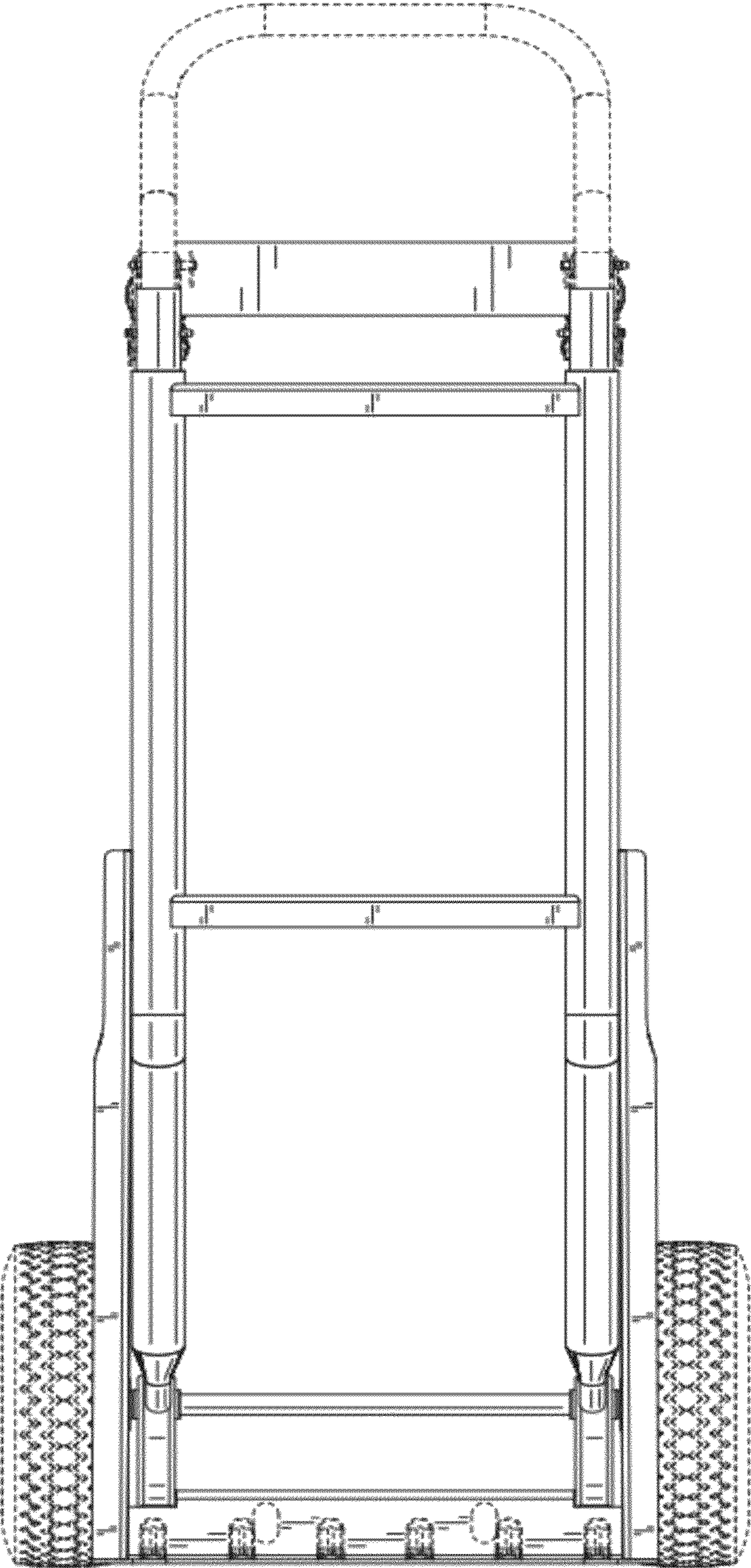

FIG. 2

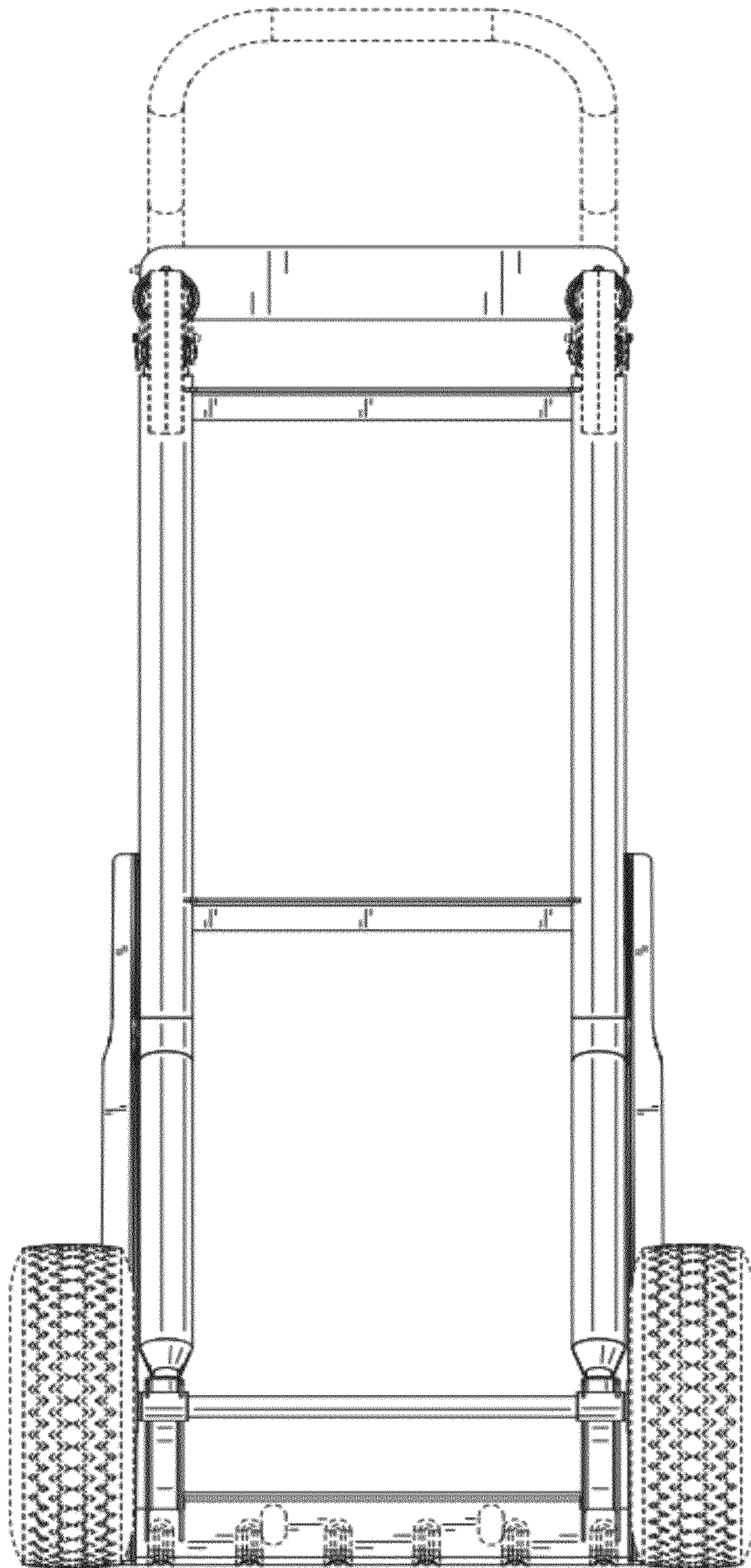

FIG. 3

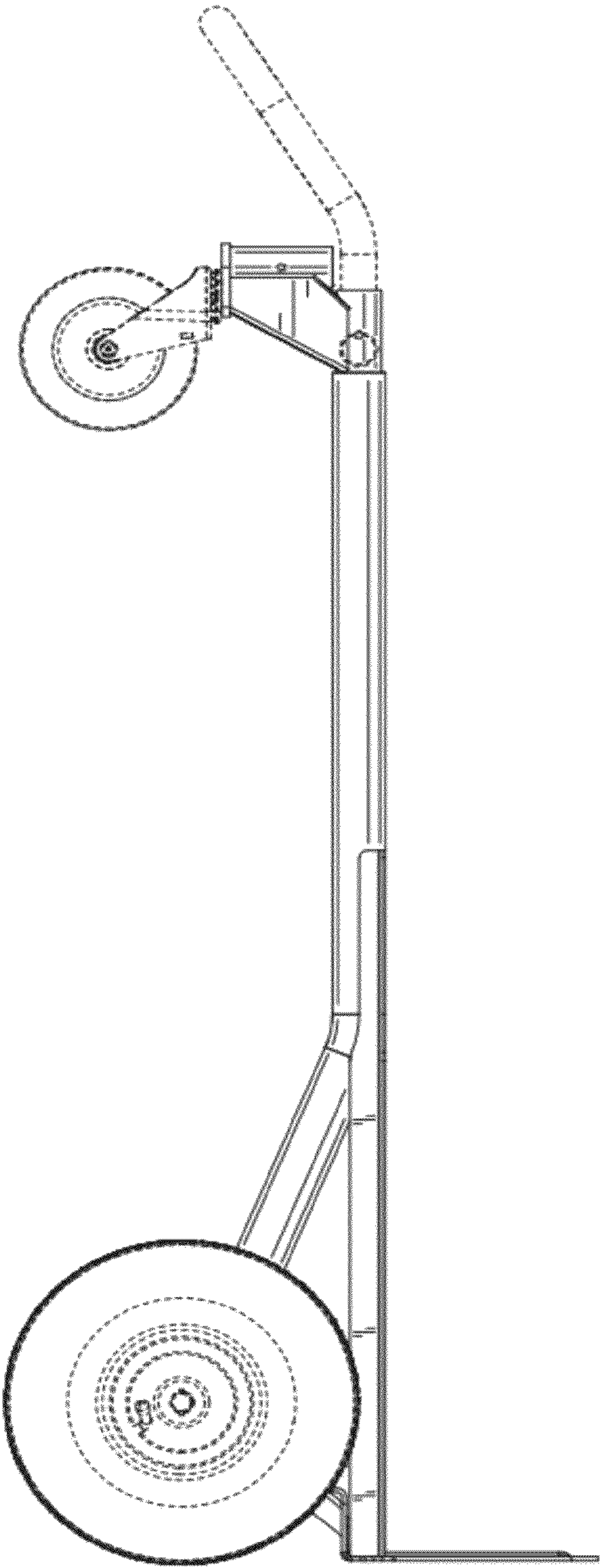

FIG. 4

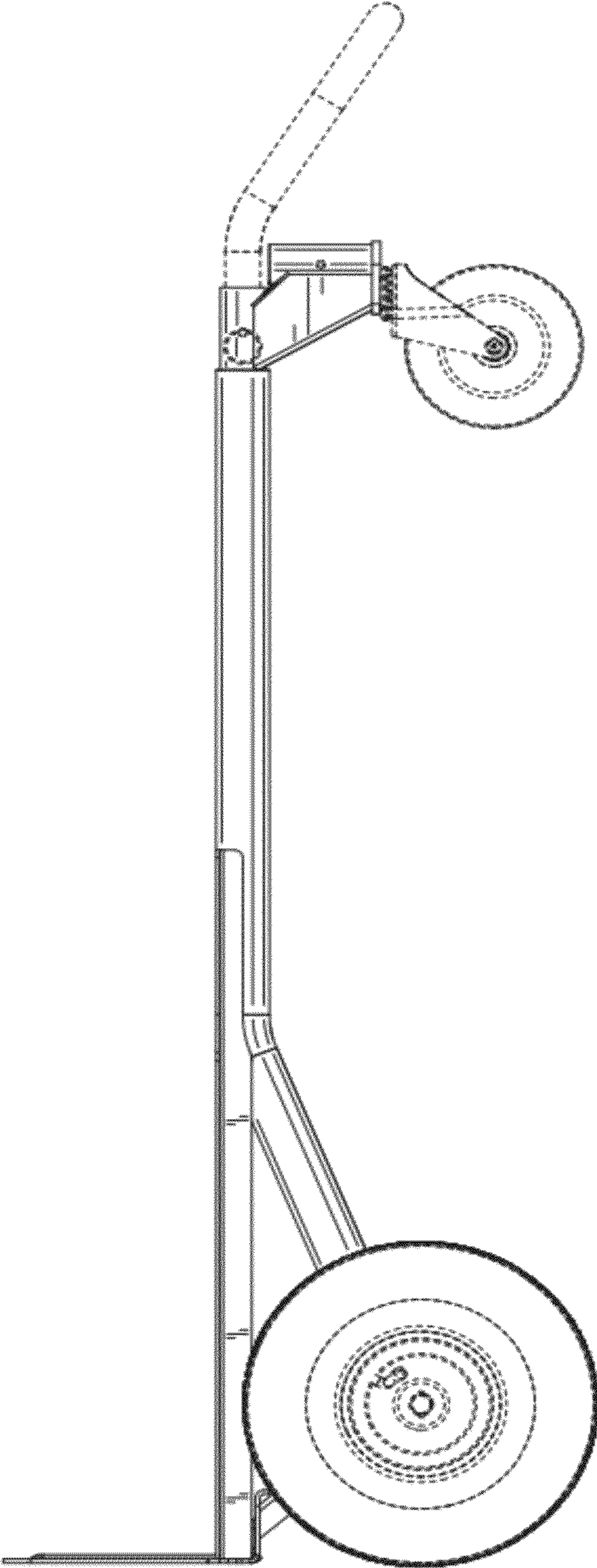

FIG. 5

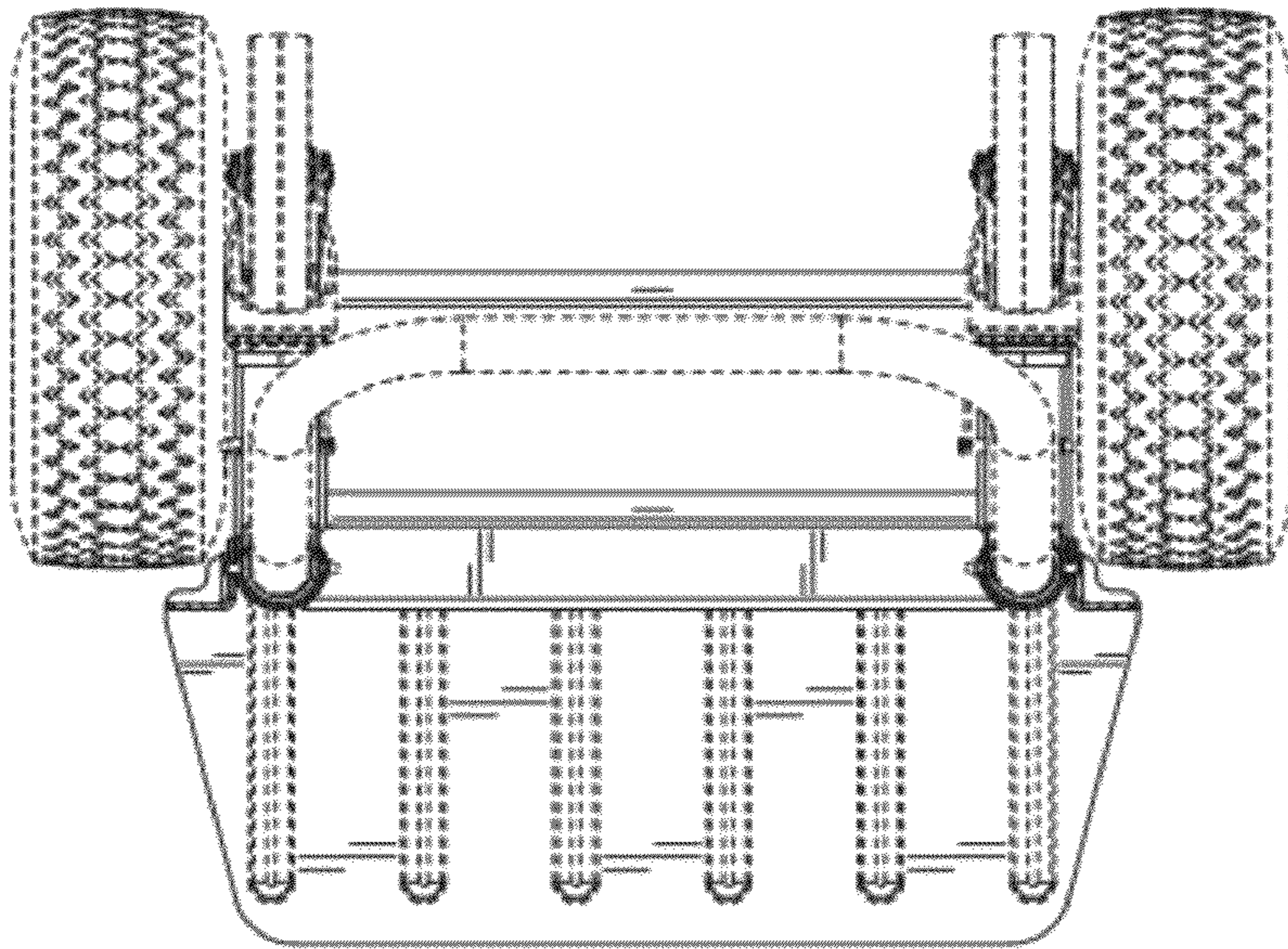

FIG. 6

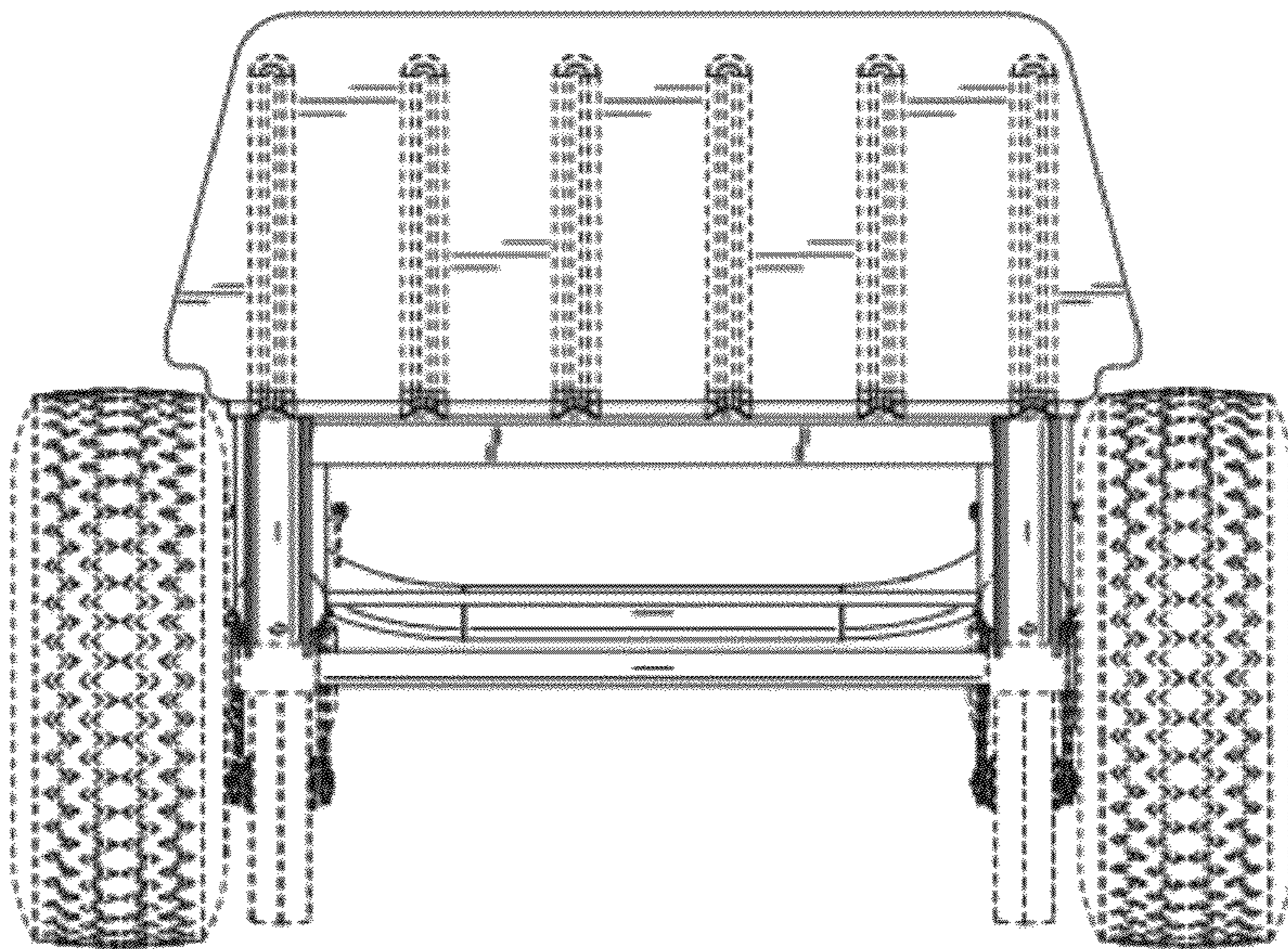

FIG. 7

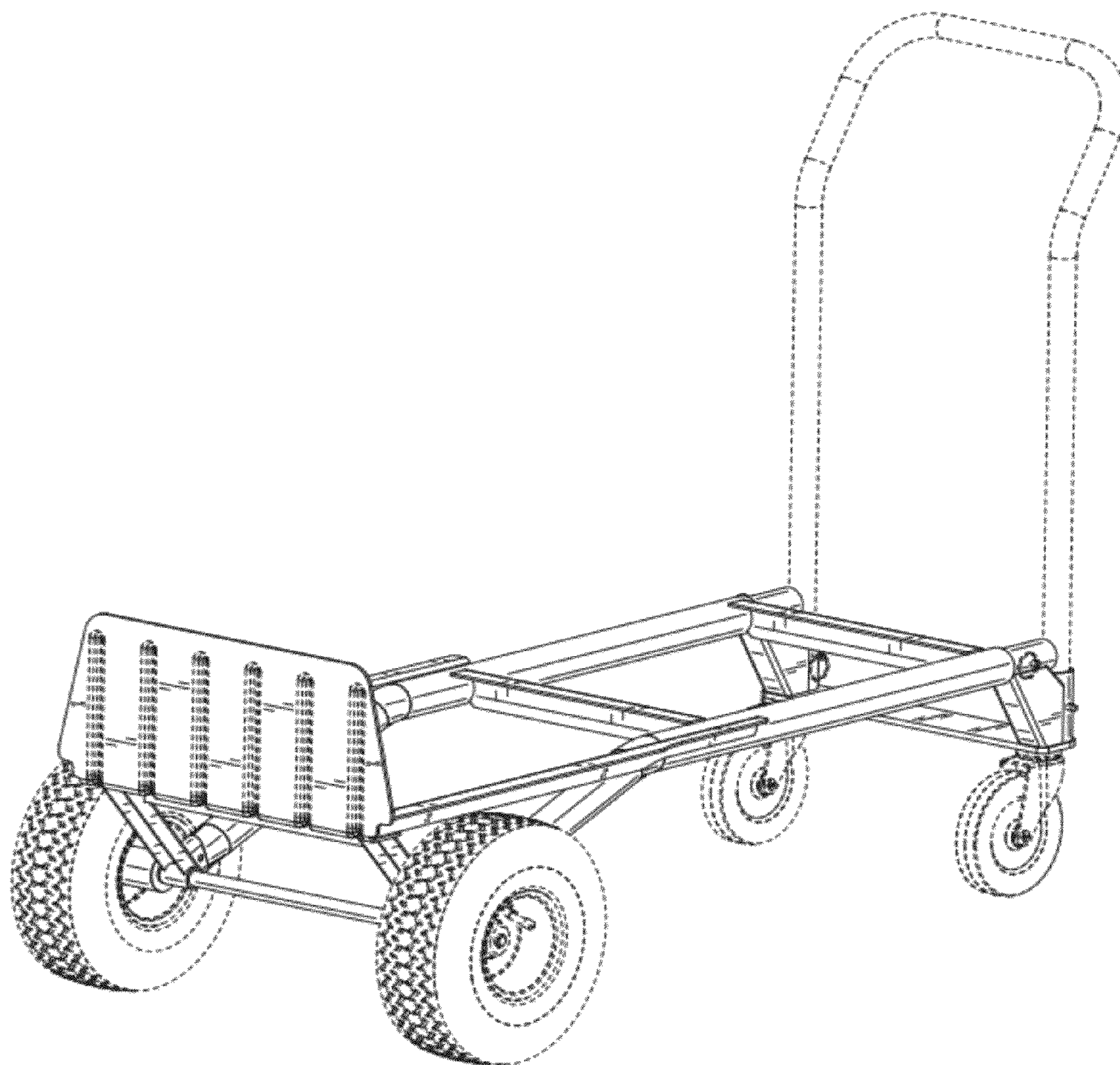

FIG. 8



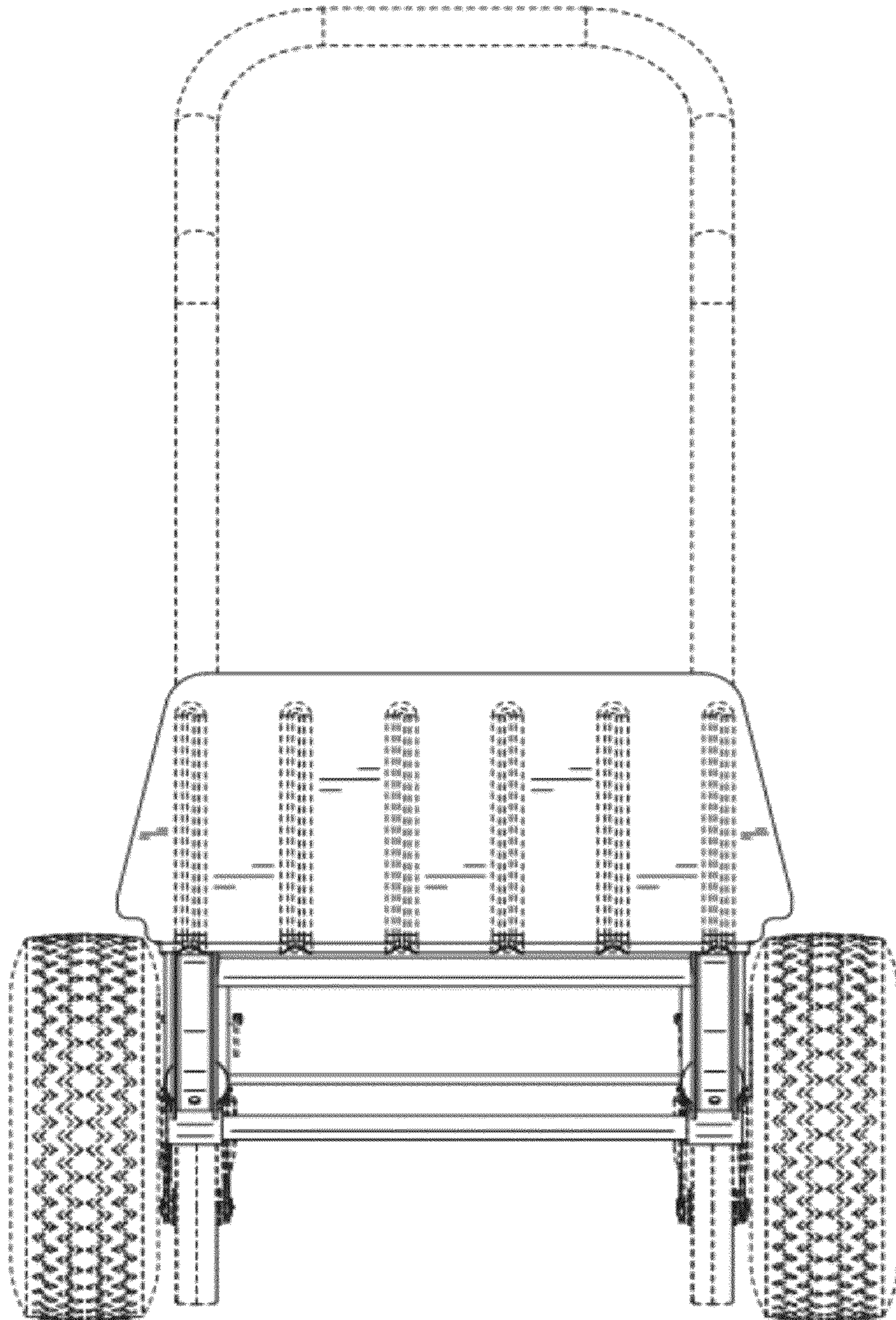

FIG. 9

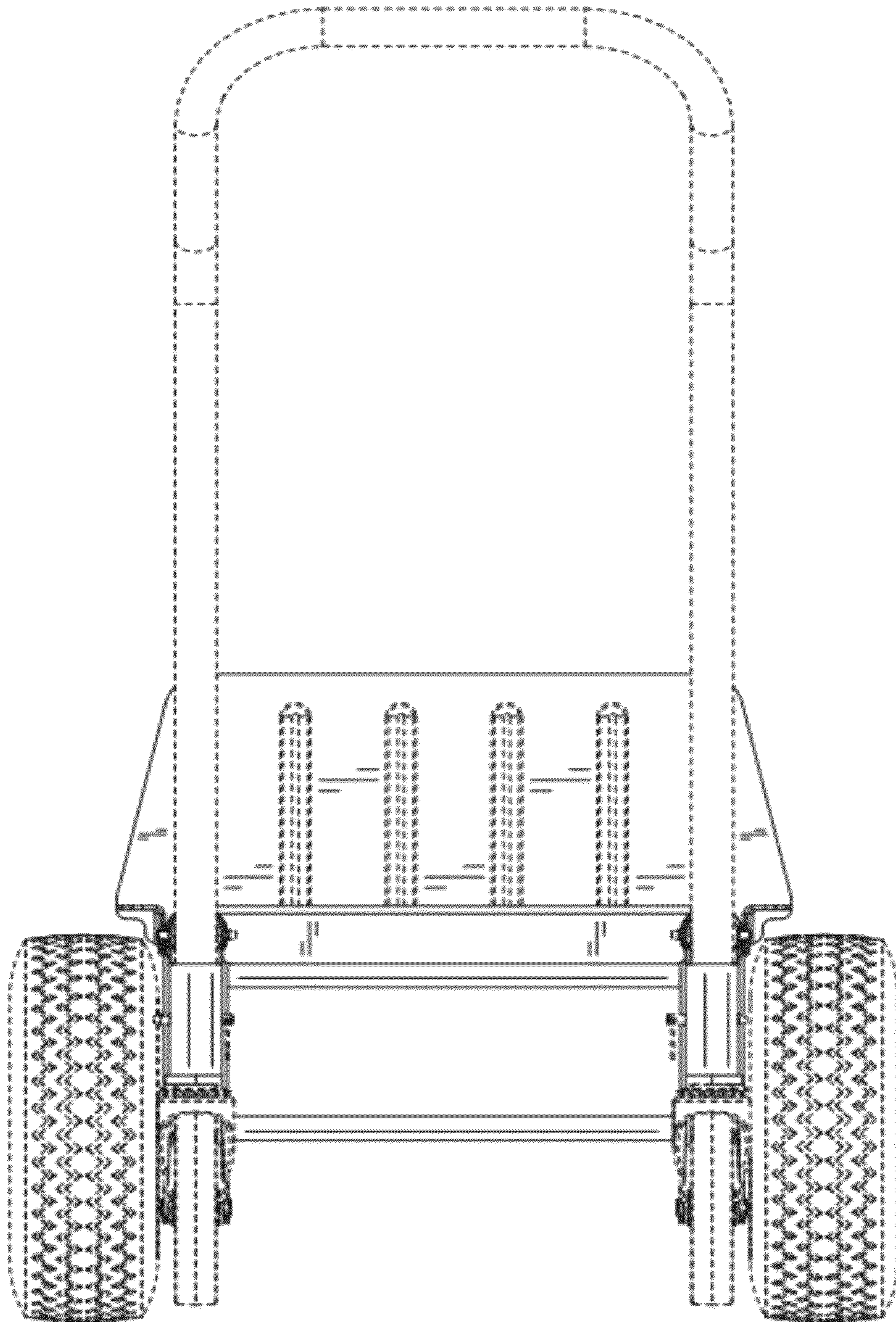
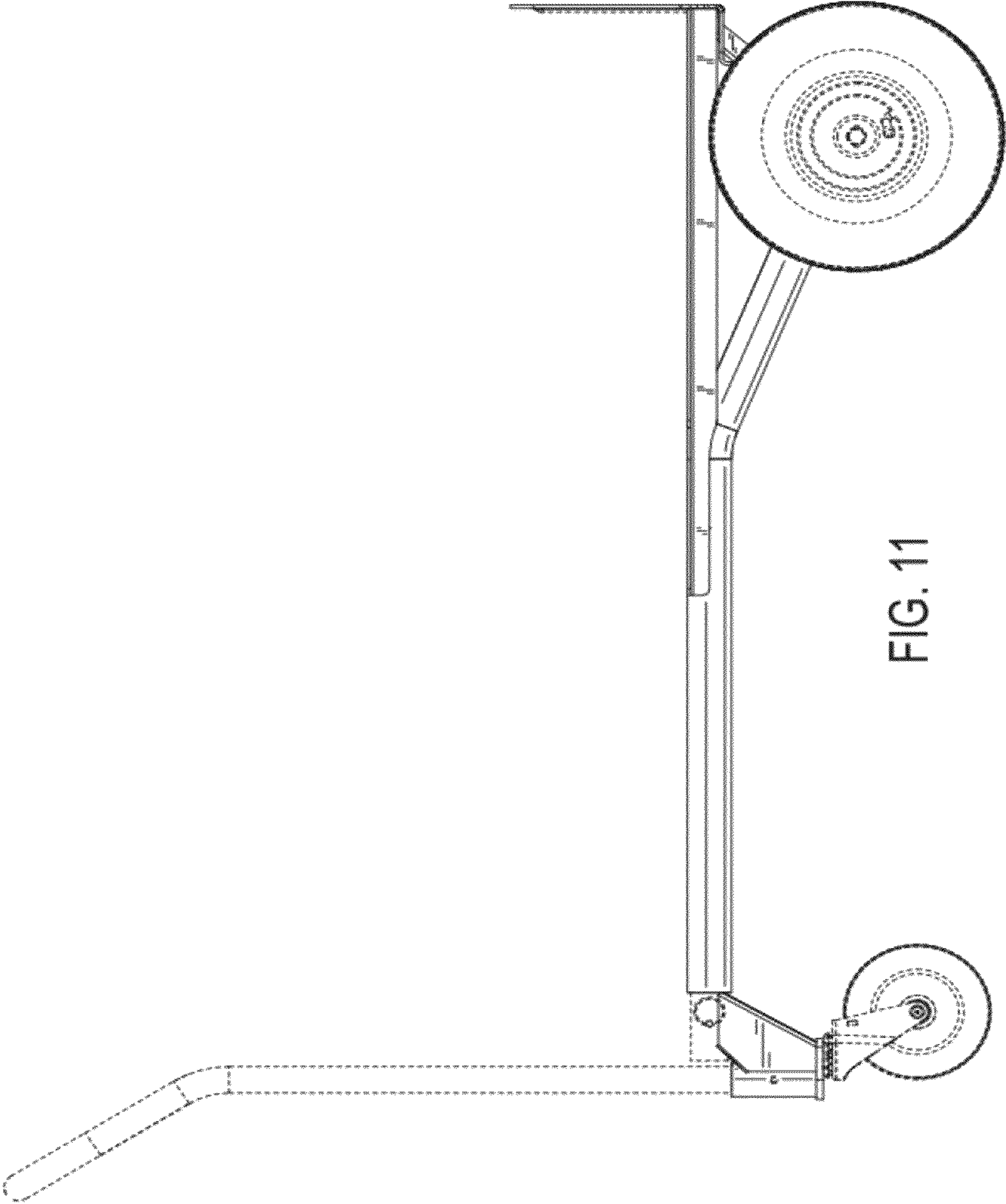

FIG. 10



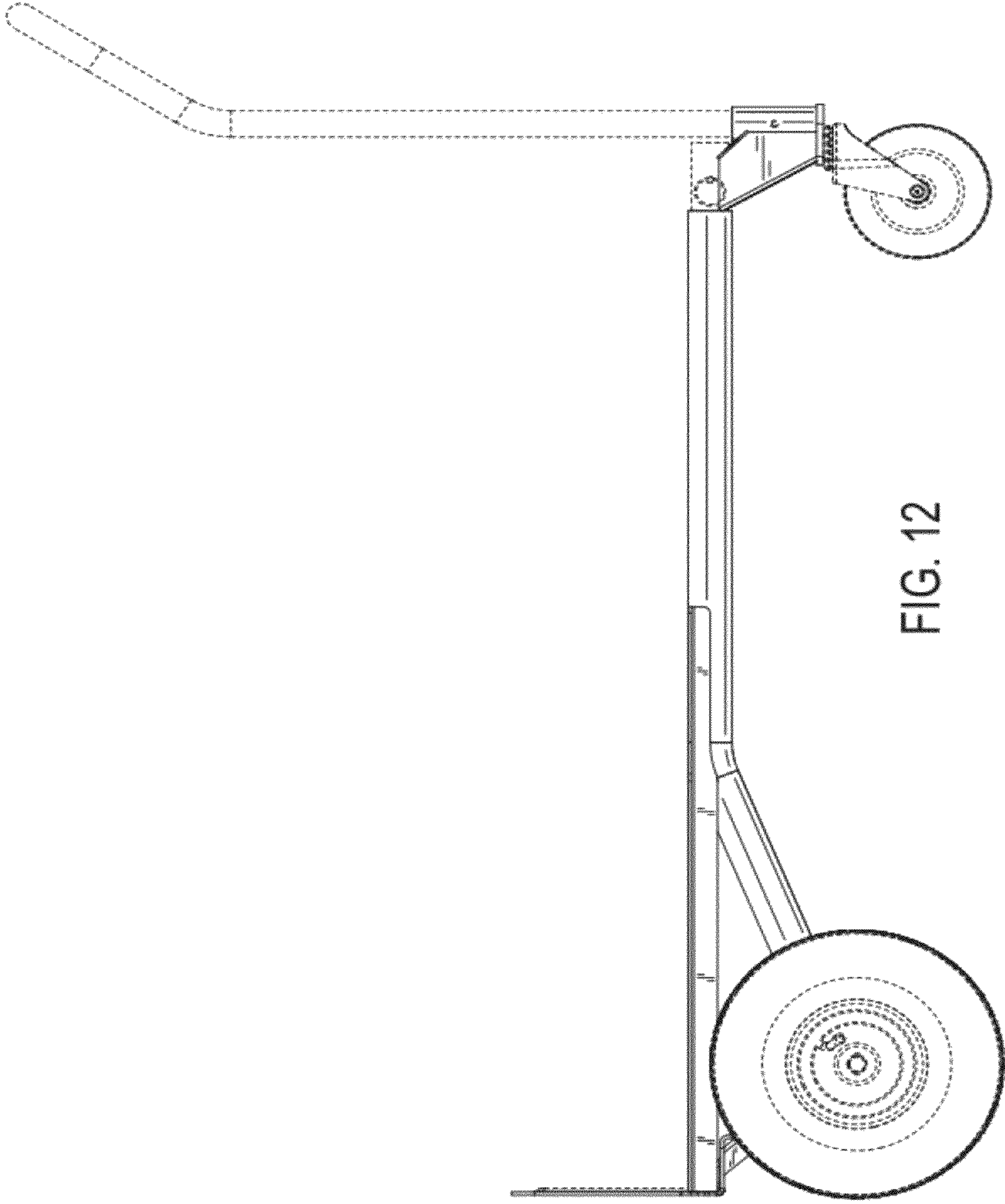

FIG. 12

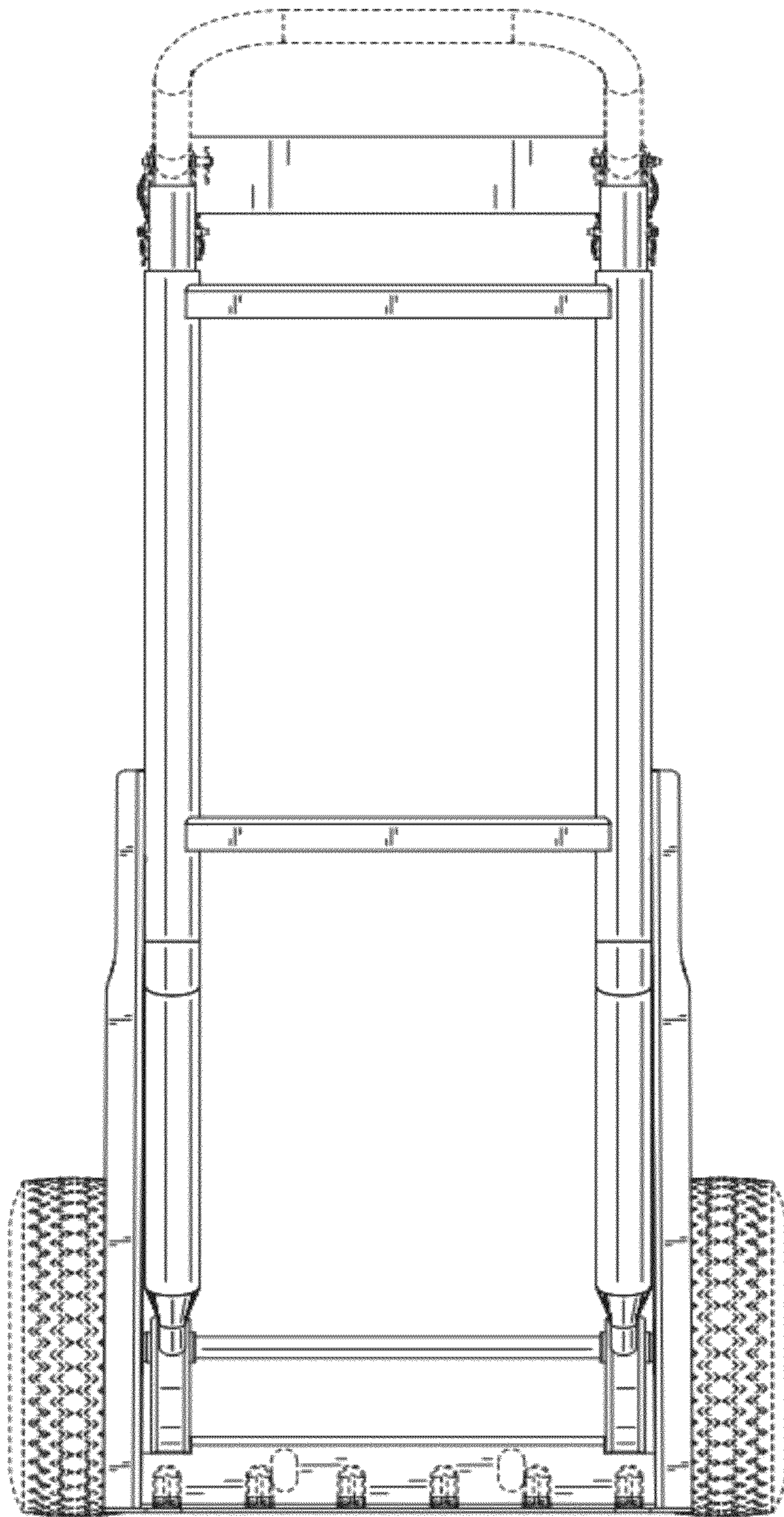

FIG. 13

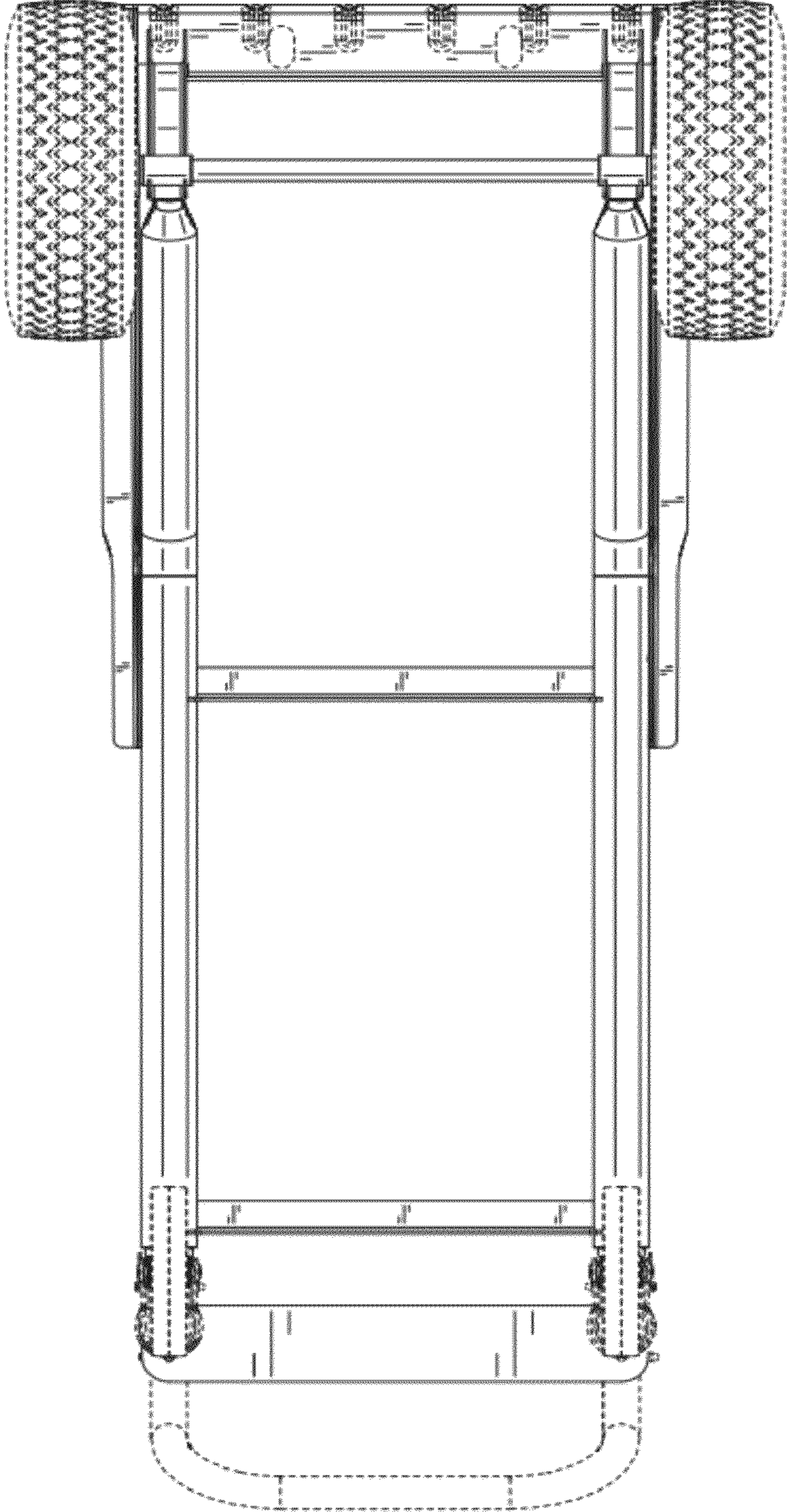

FIG. 14