

US00D666952S

(12) **United States Design Patent**  
**Pollmann**

(10) **Patent No.:** **US D666,952 S**

(45) **Date of Patent:** **\*\* Sep. 11, 2012**

(54) **WHEEL OR WHEEL COVER**

(75) **Inventor:** **Gert Pollmann**, Boehmfeld (DE)

(73) **Assignee:** **Bayerische Motoren Werke Aktiengesellschaft**, Munich (DE)

(\*\*) **Term:** **14 Years**

(21) **Appl. No.:** **29/371,128**

(22) **Filed:** **Oct. 27, 2010**

(30) **Foreign Application Priority Data**

Apr. 28, 2010 (DE) ..... 402010002511

(51) **LOC (9) Cl.** ..... **12-16**

(52) **U.S. Cl.** ..... **D12/209**

(58) **Field of Classification Search** ..... D12/204-213;  
301/37.101, 64.101, 65, 64.201

See application file for complete search history.

(56) **References Cited**

**U.S. PATENT DOCUMENTS**

D503,918 S	4/2005	Fahr-Becker	
D516,002 S *	2/2006	Fahr-Becker	D12/211
D522,434 S *	6/2006	Langer	D12/209
D522,949 S *	6/2006	Elmitt	D12/211
D567,167 S	4/2008	Forster	
D590,314 S *	4/2009	Hettler	D12/209
D594,396 S *	6/2009	Juergens et al.	D12/209
D620,417 S *	7/2010	Gallert	D12/209
D625,235 S *	10/2010	Nissl	D12/209
D627,287 S *	11/2010	Gallert	D12/209

D628,527 S	12/2010	Faghihzadeh	
D631,813 S *	2/2011	Nissl	D12/209
D644,588 S *	9/2011	Schweizer	D12/211
D645,389 S *	9/2011	Nissl	D12/209
D651,550 S *	1/2012	Elmitt	D12/209

**FOREIGN PATENT DOCUMENTS**

EM	000141791-0005	6/2004
EM	000255609-0004	2/2005
EM	000735758-0006	7/2007
EM	001693599-0004	4/2010
EM	001636978-0020	11/2010

\* cited by examiner

*Primary Examiner* — Stacia Cadmus

(74) *Attorney, Agent, or Firm* — Crowell & Moring LLP

(57) **CLAIM**

The ornamental design for a wheel or wheel cover, as shown and described.

**DESCRIPTION**

This application contains subject matter related to the following co-pending U.S. design patent application:

Application Ser. No. 29/347,270, filed Nov. 19, 2009 and entitled "Wheel or Wheel Cover."

FIG. 1 is a front view of a wheel or wheel cover according to my design; and,

FIG. 2 is a perspective view thereof.

The broken line showing of the rear of the wheel and the bolt holes and center opening in the central hub area is included for the purpose of illustrating environment and forms no part of the claimed design.

**1 Claim, 1 Drawing Sheet**

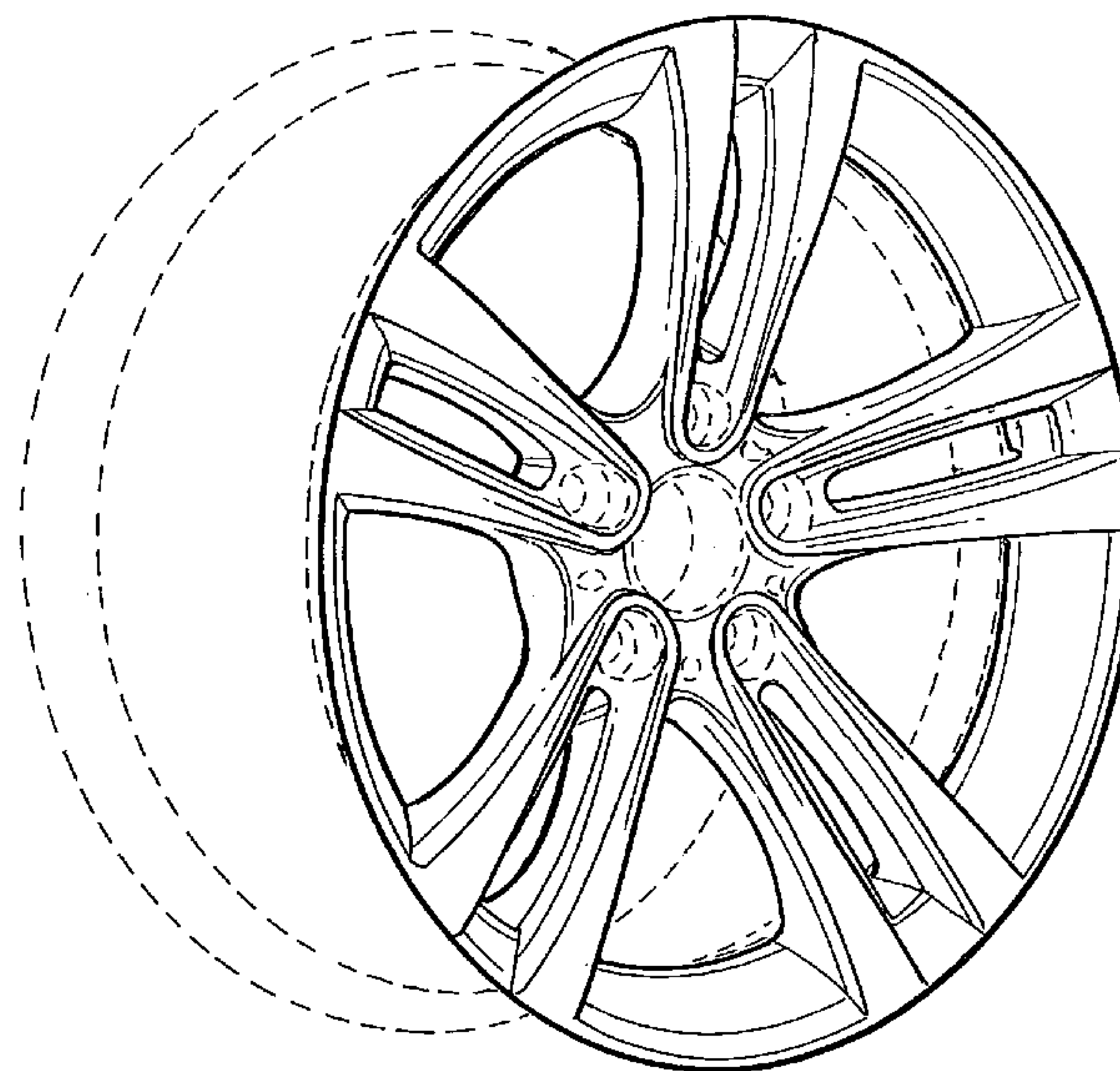
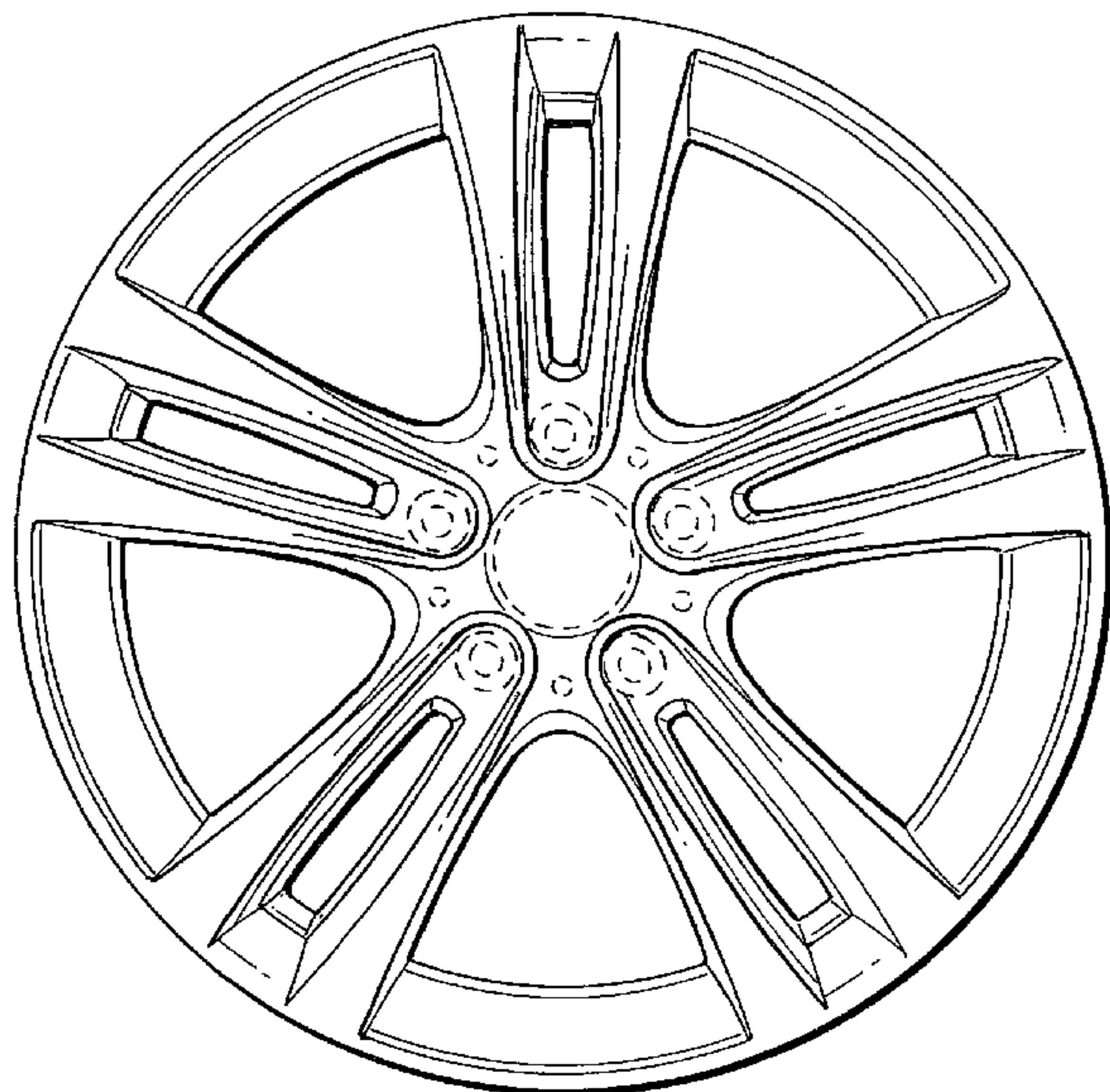

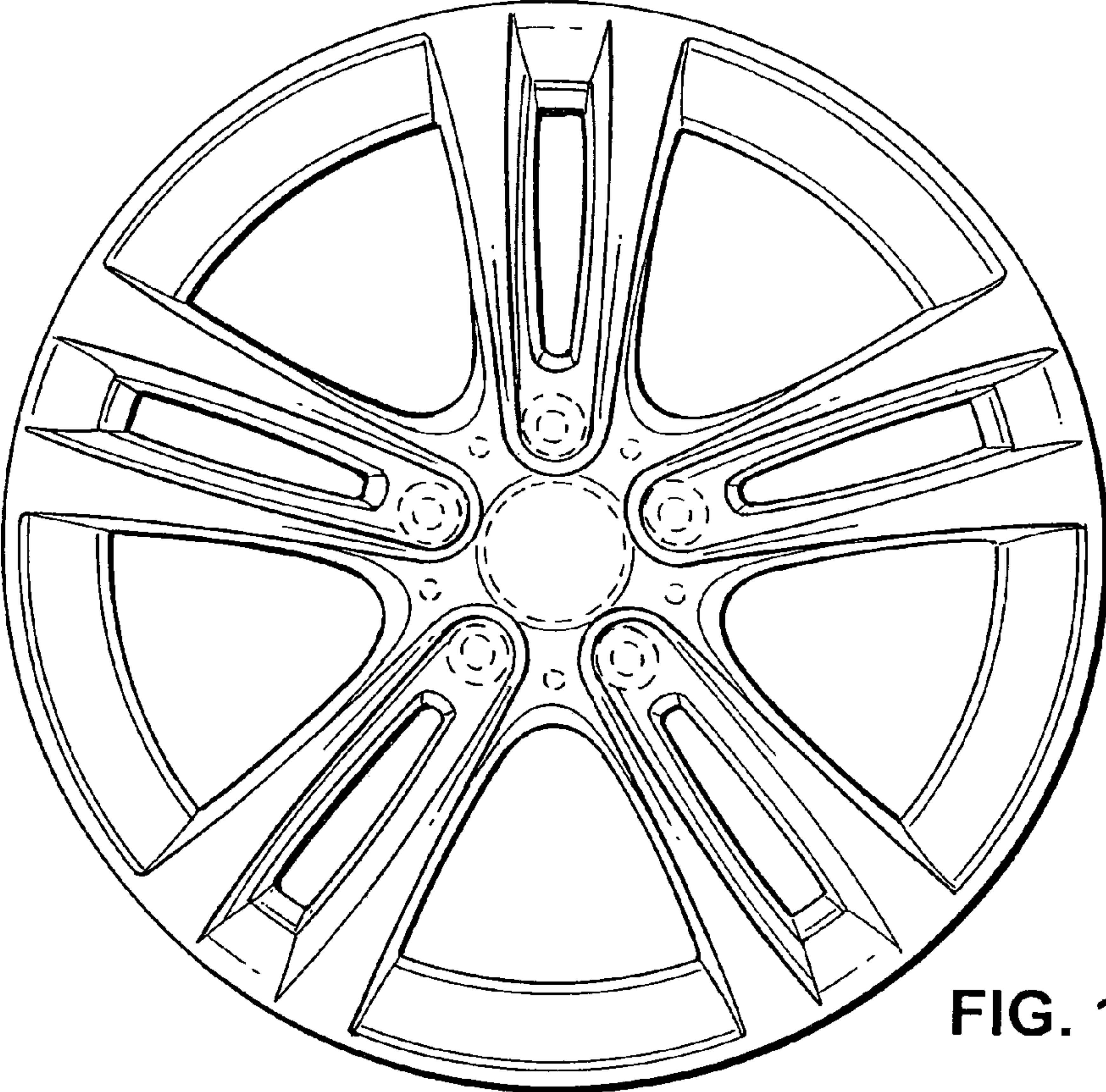

FIG. 1

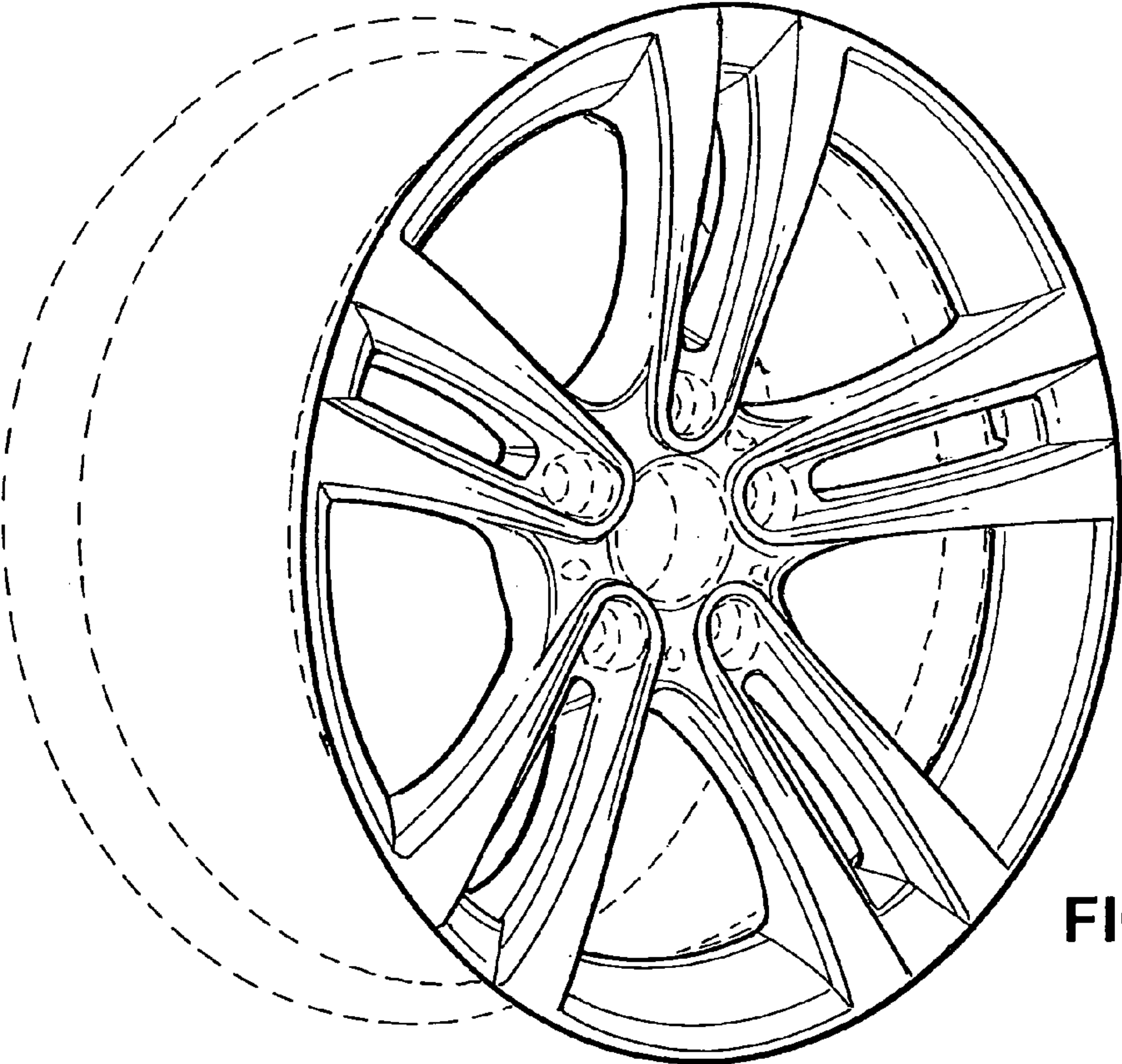

FIG. 2