



US00D666891S

(12) **United States Design Patent**  
**Gulseth**

(10) **Patent No.:** **US D666,891 S**

(45) **Date of Patent:** **\*\* Sep. 11, 2012**

(54) **VEHICLE EMERGENCY ESCAPE WINDOW HANDLE**

(75) Inventor: **Gregory W. Gulseth**, Farmington, MN (US)

(73) Assignee: **BAE Systems Land & Armaments, L.P.**, Santa Clara, CA (US)

(\*\*) Term: **14 Years**

(21) Appl. No.: **29/400,788**

(22) Filed: **Sep. 1, 2011**

(51) **LOC (9) Cl.** ..... **08-06**

(52) **U.S. Cl.** ..... **D8/308**

(58) **Field of Classification Search** ..... D8/300,  
D8/301, 302, 303, 308; D3/318; D24/183,  
D24/184; D34/35, 34, 28; 16/110.1, 114.1;  
190/115; 244/234, 236; 280/43.12; D12/179;  
187/222

See application file for complete search history.

(56) **References Cited**

**U.S. PATENT DOCUMENTS**

245,144	A	8/1881	Dicer	
457,387	A	8/1891	Vose	
551,534	A	12/1895	Esmond	
626,332	A *	6/1899	Mason	280/47.27
3,026,089	A *	3/1962	Meister	280/43.12
D215,814	S *	11/1969	Kraus	D8/308
D219,861	S *	2/1971	Coffman	D8/308
D248,822	S *	8/1978	Taniwaki	D8/354
4,285,536	A *	8/1981	McCoy et al.	292/336.3
4,364,592	A	12/1982	Jackson	
D268,984	S *	5/1983	Bergen	D8/308
4,502,719	A *	3/1985	Perry	292/347
D289,369	S *	4/1987	Foshee	D8/308
4,714,282	A *	12/1987	Henderson	292/36
4,955,159	A *	9/1990	Rogers	49/161
5,169,205	A	12/1992	James	
5,210,905	A	5/1993	Dietz et al.	

5,813,504	A *	9/1998	Iny et al.	190/116
5,857,730	A *	1/1999	Korpi et al.	296/146.1
D422,409	S *	4/2000	Klenner et al.	D3/279
6,122,800	A *	9/2000	Cheng	16/113.1
D448,537	S *	9/2001	Harrah	D34/35
D486,648	S *	2/2004	Fenton	D3/318
D510,231	S *	10/2005	Coudurier	D7/393
D526,109	S *	8/2006	Bergman et al.	D34/35
7,124,475	B2	10/2006	Jeffries	
D538,504	S *	3/2007	Pham	D34/35
D596,917	S *	7/2009	Donaldson et al.	D8/308

(Continued)

**OTHER PUBLICATIONS**

File History for U.S. Appl. No. 13/304,016, filed Nov. 23, 2011.  
Inventors: Michael K. Hafften et al.  
File History for U.S. Patent No. 8,066,319 B2, issued Nov. 29, 2011.  
Inventors: Michael L. Hafften et al.

(Continued)

*Primary Examiner* — Paula Greene

(74) *Attorney, Agent, or Firm* — Patterson Thuent Christensen Pedersen, P.A.

(57) **CLAIM**

The ornamental design for a vehicle emergency escape window handle, as shown and described.

**DESCRIPTION**

FIG. 1 is a front perspective view of a vehicle emergency escape window handle according to the invention. FIG. 2 is a rear perspective view of the vehicle emergency escape window handle depicted in FIG. 1. FIG. 3 is a side elevation view of the vehicle emergency escape window handle depicted in FIG. 1. FIG. 4 is a top elevation view of the vehicle emergency escape window handle depicted in FIG. 1; and, FIG. 5 is a rear elevation view of the vehicle emergency escape window handle depicted in FIG. 1.

**1 Claim, 2 Drawing Sheets**

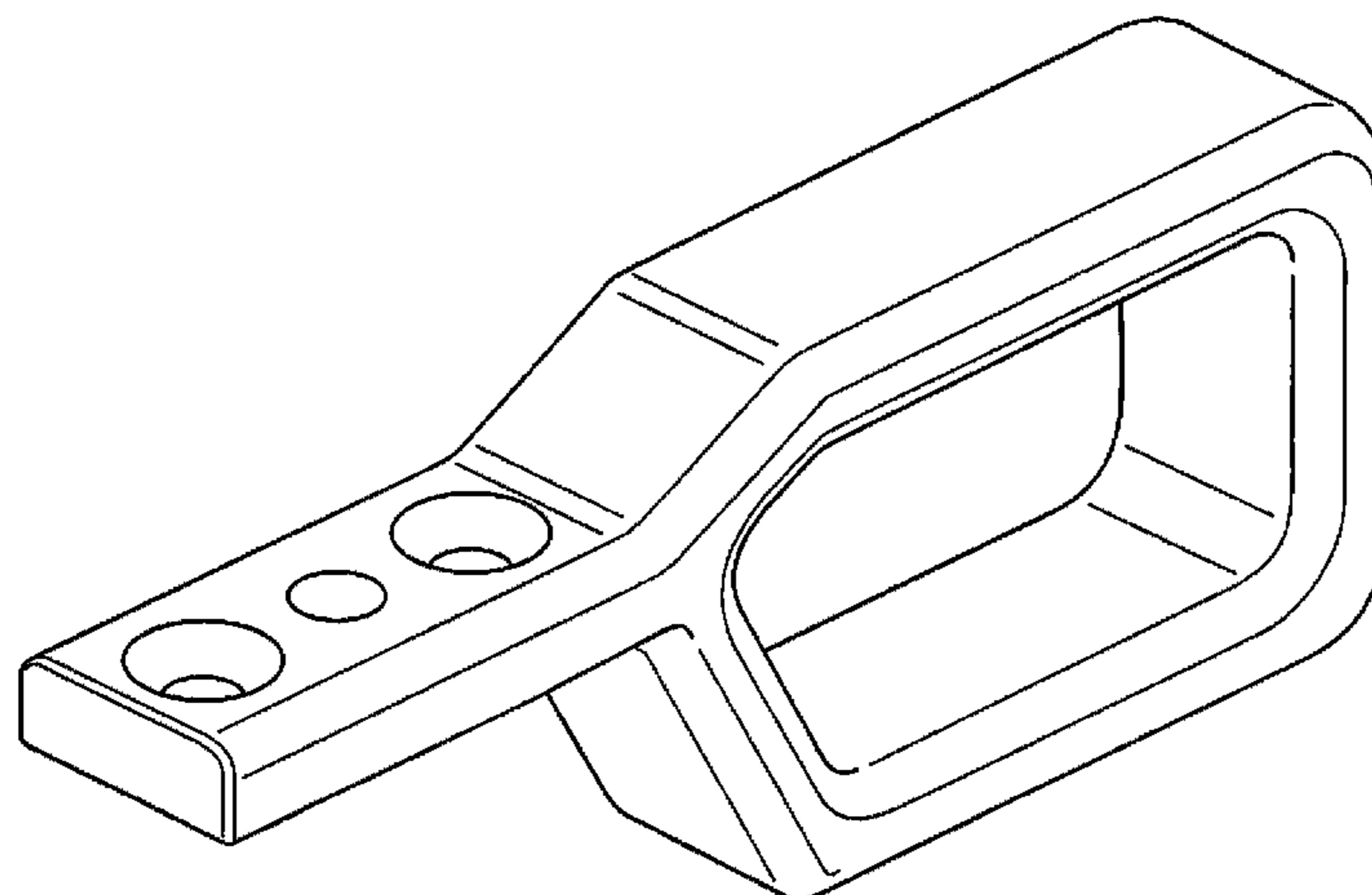

# US D666,891 S

Page 2

---

## U.S. PATENT DOCUMENTS

D598,240 S \* 8/2009 Josancy ..... D7/394  
D615,383 S \* 5/2010 Donaldson et al. .... D8/308  
D615,841 S \* 5/2010 Donaldson et al. .... D8/308  
D620,748 S \* 8/2010 Munari ..... D7/394  
8,066,319 B2 11/2011 Hafften et al.

2012/0032470 A1 2/2012 Hafften et al.

## OTHER PUBLICATIONS

File History for U.S. Appl. No. 13/279,838, mailed Oct. 24, 2011.  
Inventors: Michael L. Hafften et al.

\* cited by examiner

**Fig. 1**

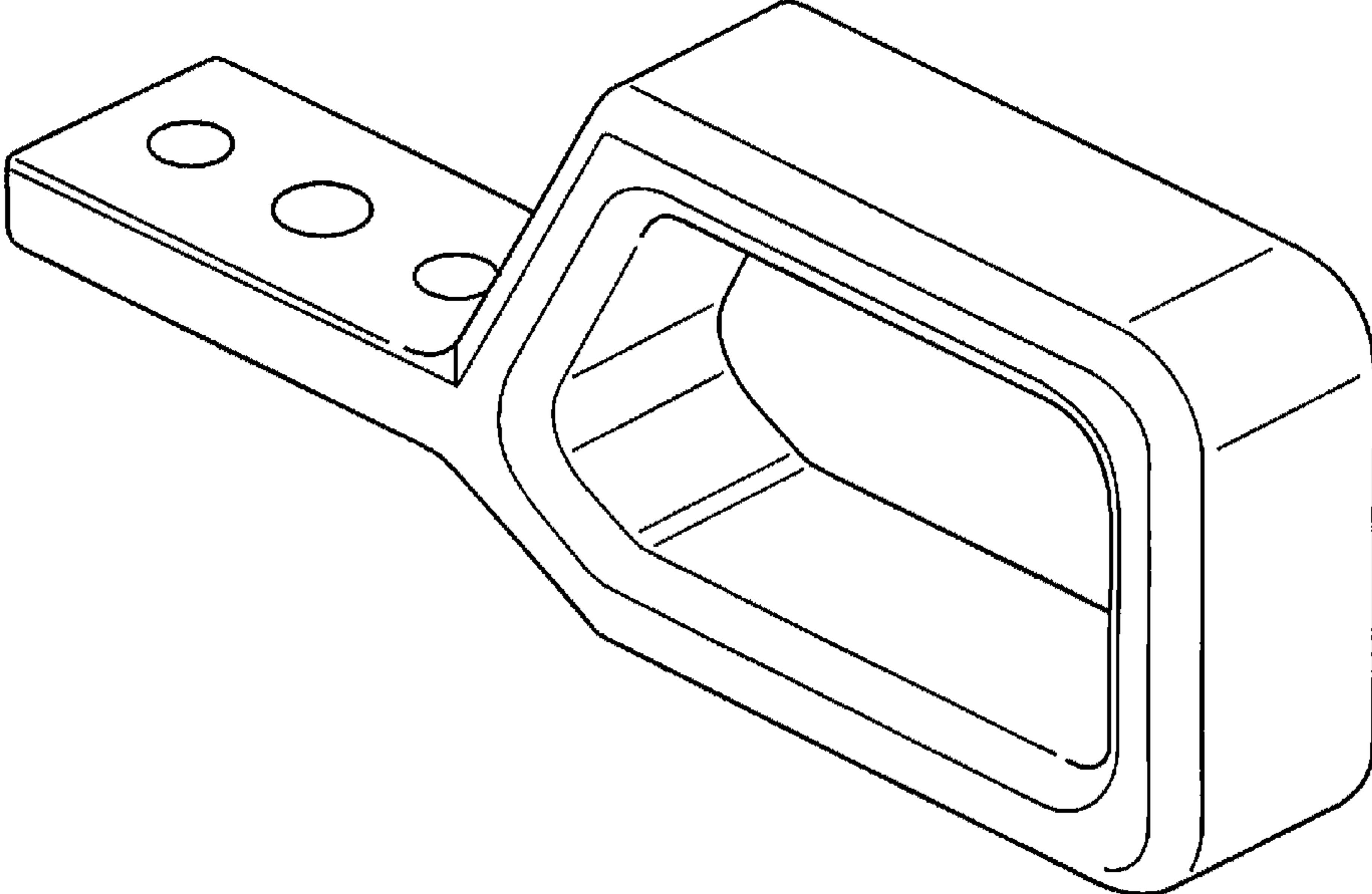

**Fig. 2**

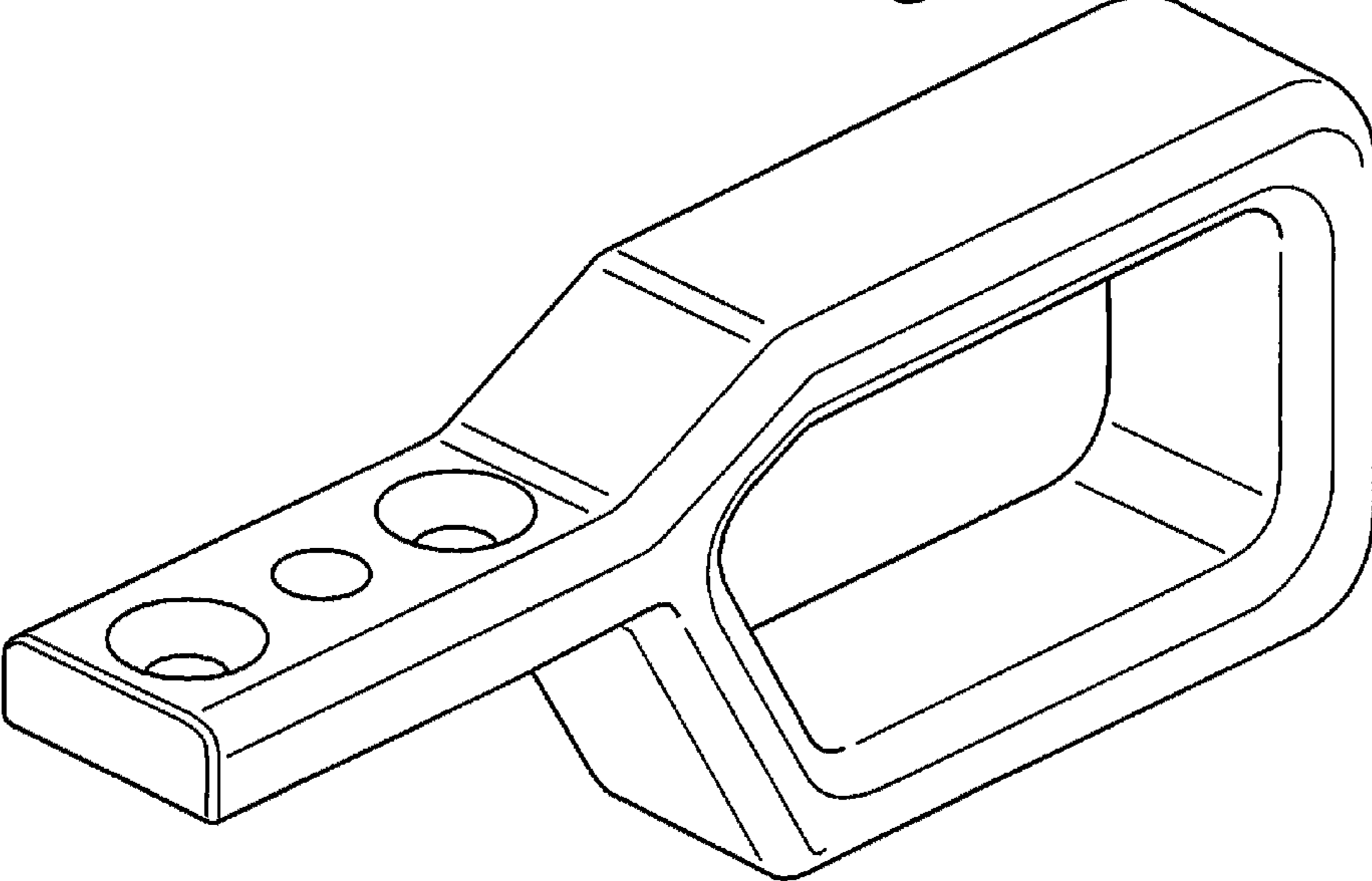

**Fig. 3**

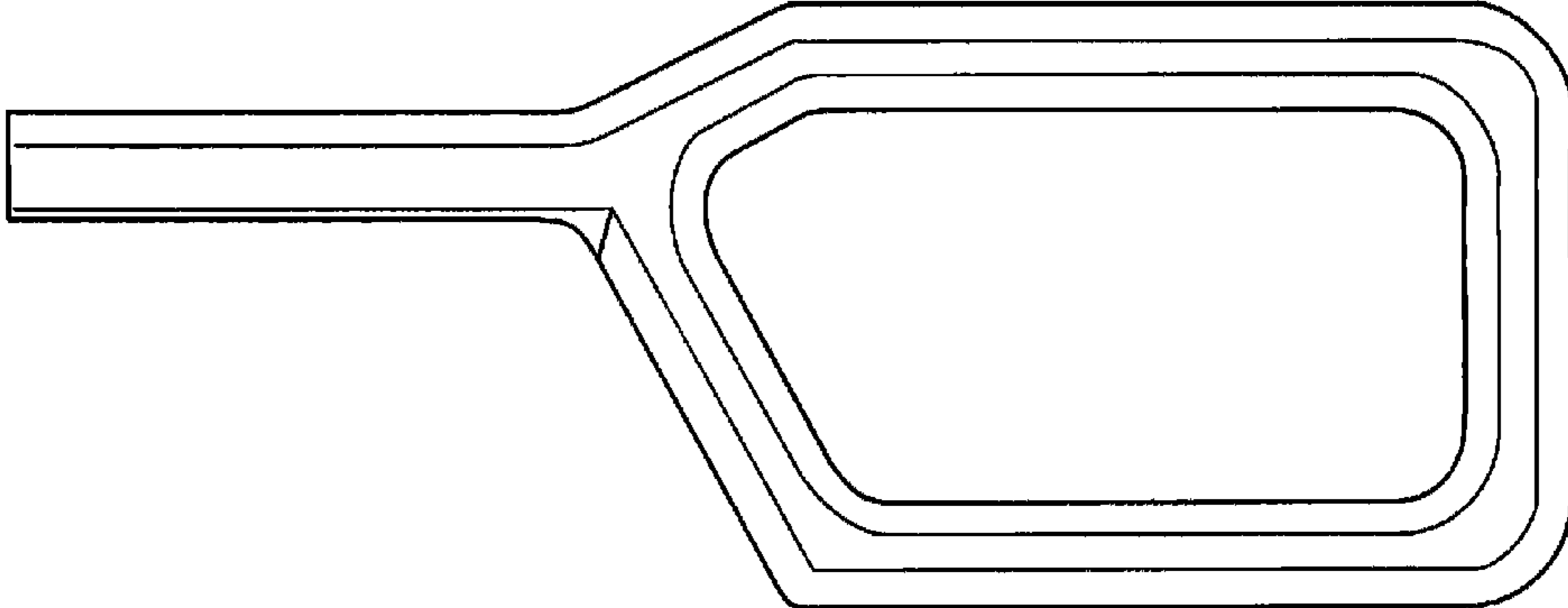

**Fig. 4**

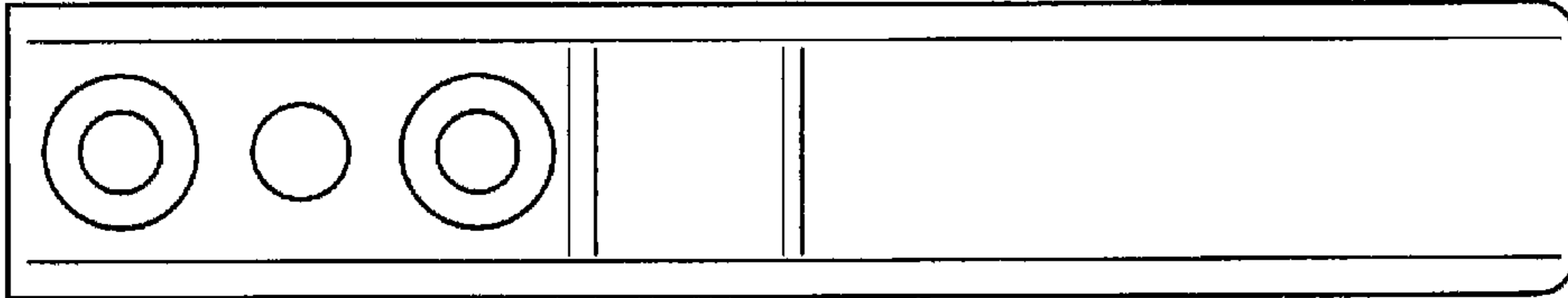

**Fig. 5**

