



US00D666889S

(12) **United States Design Patent**
Yu et al.

(10) **Patent No.:** **US D666,889 S**
(45) **Date of Patent:** **** Sep. 11, 2012**

(54) **VEHICLE INTERIOR DOOR HANDLE**

(75) Inventors: **Simon H Yu**, Los Angeles, CA (US);
Jeffrey P. Freiling, Torrance, CA (US)

(73) Assignee: **Honda Motor Co., Ltd.**, Tokyo (JP)

(**) Term: **14 Years**

(21) Appl. No.: **29/375,368**

(22) Filed: **Sep. 21, 2010**

(51) **LOC (9) Cl.** **08-06**

(52) **U.S. Cl.** **D8/302**

(58) **Field of Classification Search** D8/308,
D8/300, 301, 302, 303, 313, 315, 331, 338,
D8/341; D12/190, 196; 16/110.1, 402, 412,
16/444; 292/165, 336.3, 347, 348, 353, DIG. 3;
70/135, 137, 210

See application file for complete search history.

(56) **References Cited**

U.S. PATENT DOCUMENTS

6,363,577 B1 * 4/2002 Spitzley 292/336.3
D529,850 S * 10/2006 Yu et al. D12/195
D531,880 S * 11/2006 Wang D8/302

7,284,776 B2 * 10/2007 Cummins et al. 292/336.3
D577,566 S * 9/2008 Grohmann D8/308
D593,396 S * 6/2009 Habib D8/308

* cited by examiner

Primary Examiner — Derrick Holland

(74) *Attorney, Agent, or Firm* — Plumsea Law Group, LLC;
Mark E. Duell

(57) **CLAIM**

The ornamental design for a vehicle interior door handle, as shown and described.

DESCRIPTION

FIG. 1 is a perspective view of a vehicle interior door handle showing our new design;

FIG. 2 is a side elevational view thereof; and,

FIG. 3 is a top plan view thereof.

The broken lines shown represent unclaimed subject matter and form no part of the claim. Where broken lines abut a claimed surface it is understood that those broken lines represent an unclaimed boundary between claimed and unclaimed surfaces. None of the broken lines form any part of the claimed design.

1 Claim, 2 Drawing Sheets

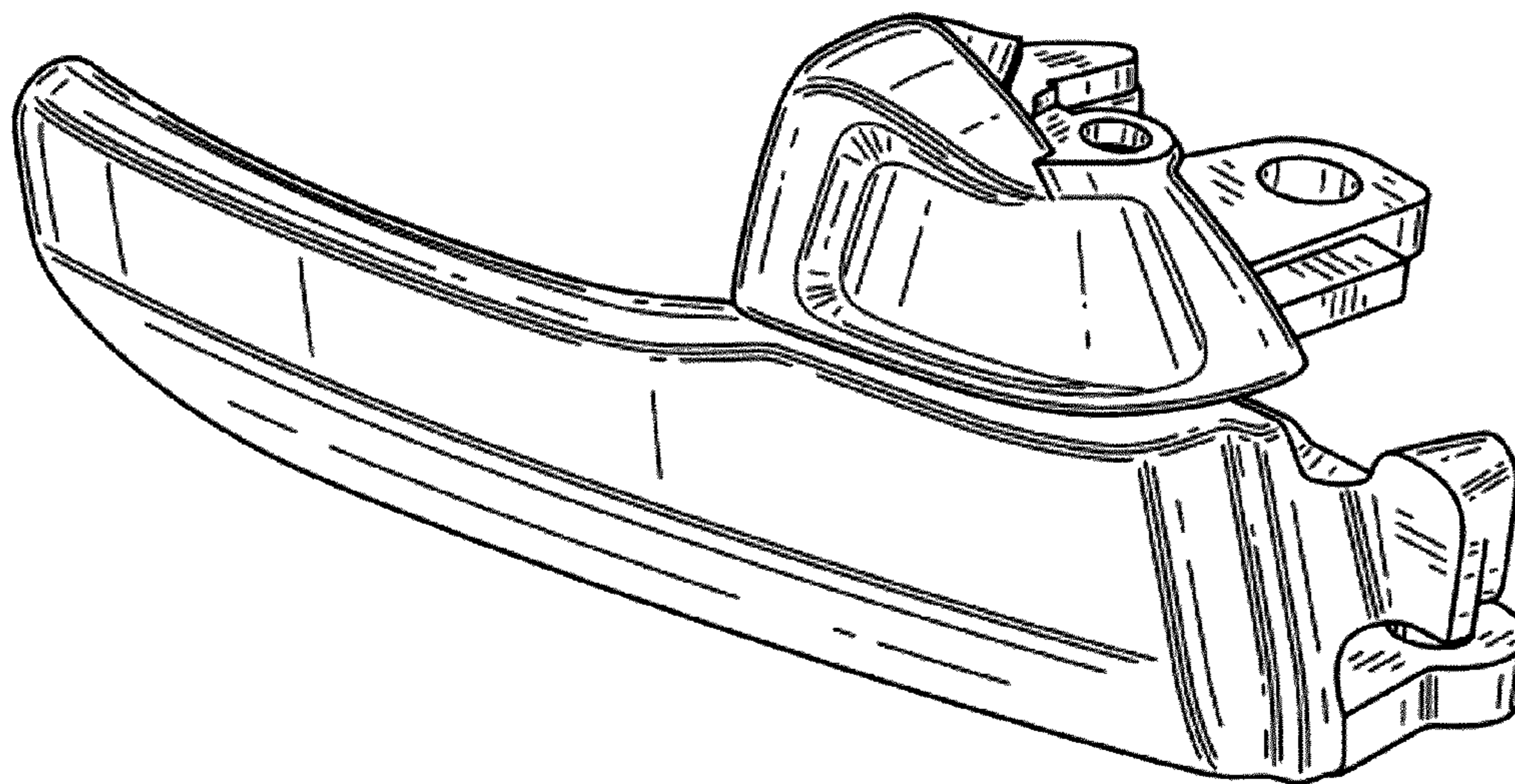

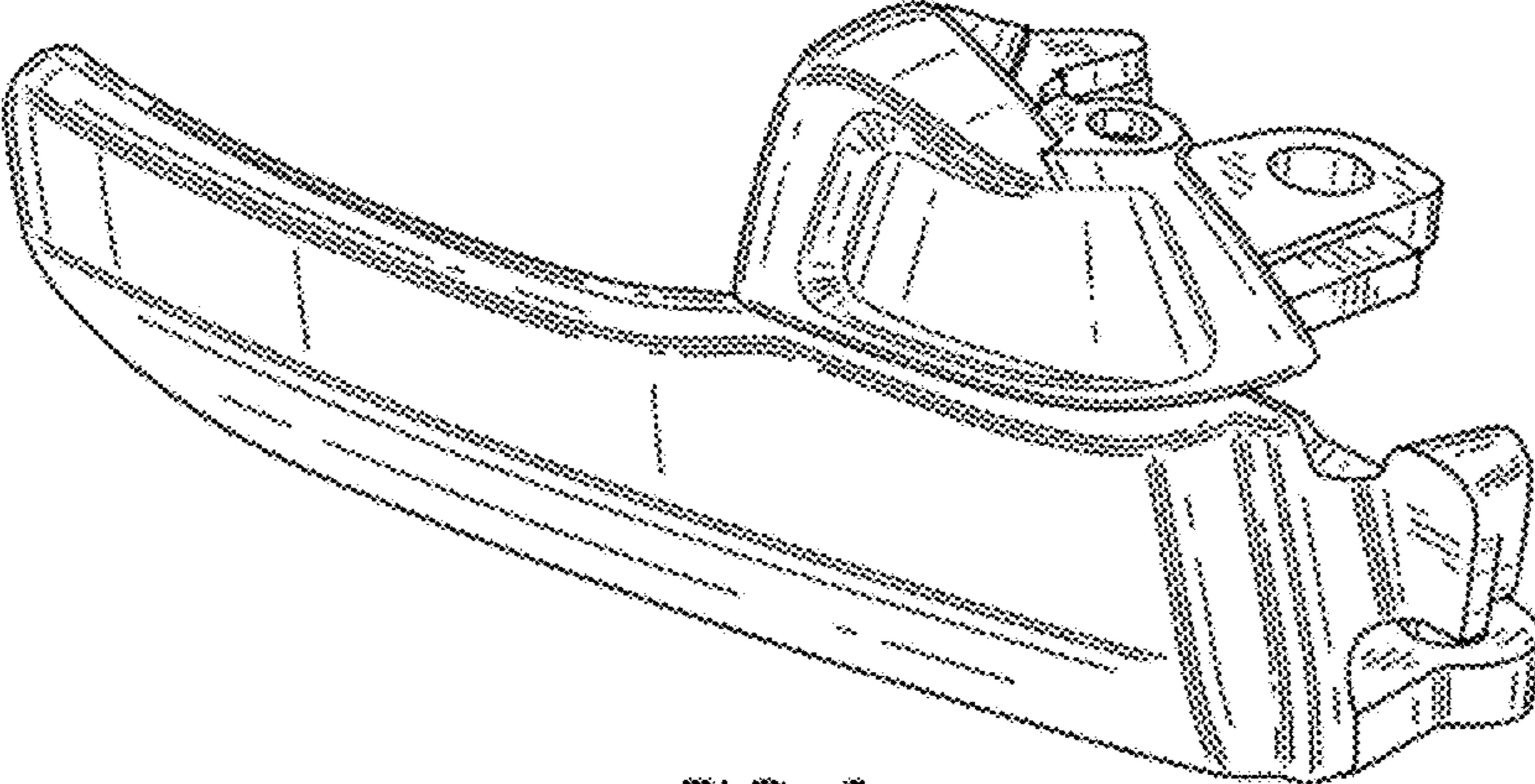

FIG. 1

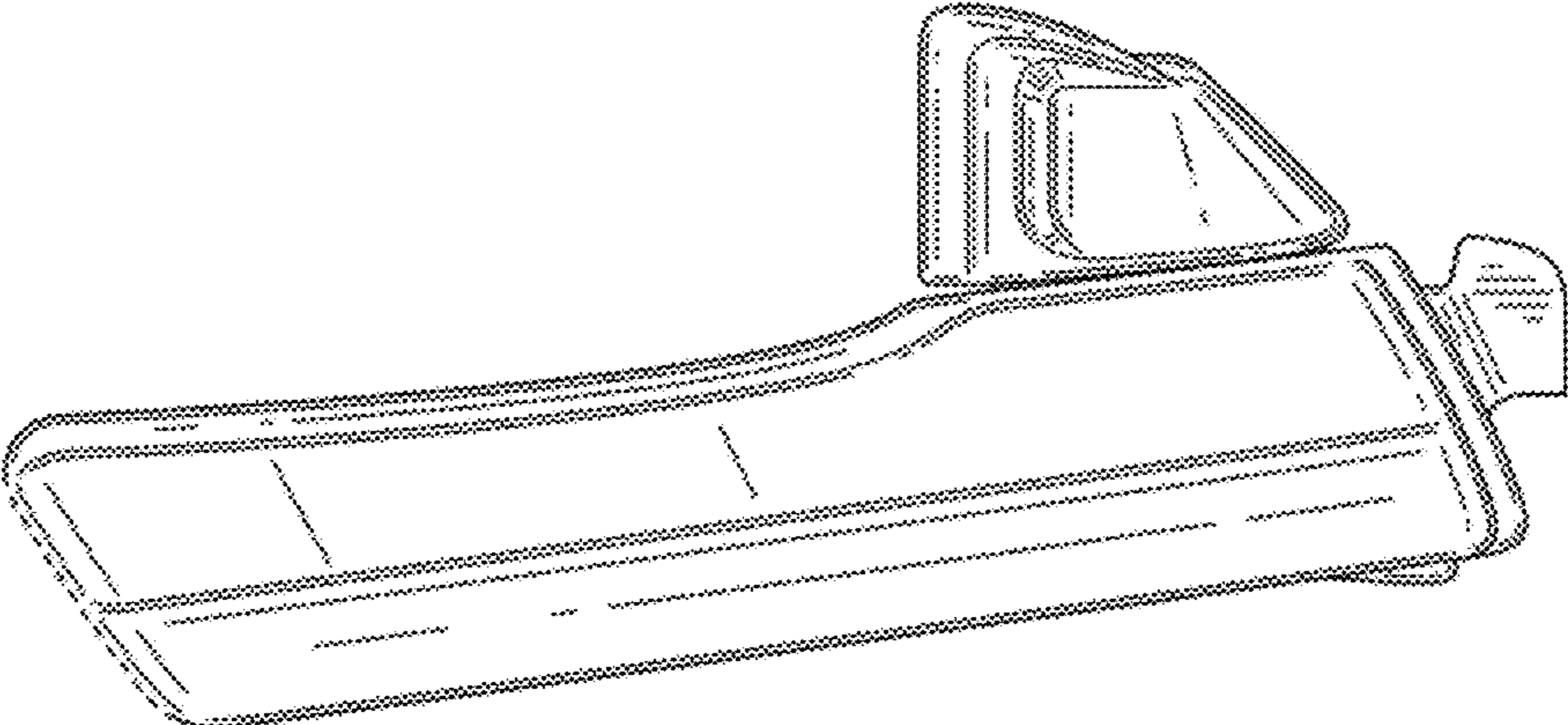

FIG. 2

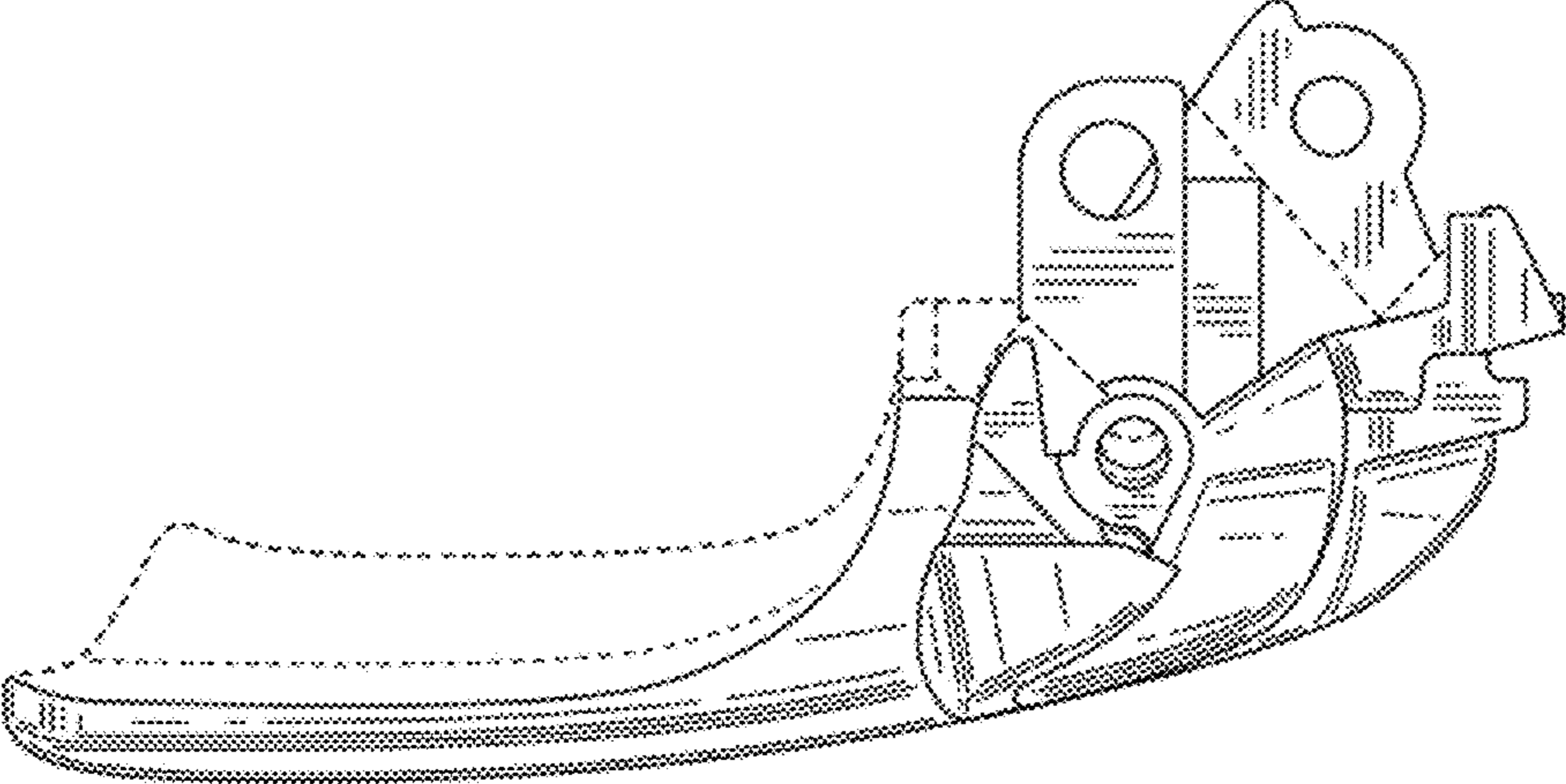

FIG. 3