

US00D666743S

(12) **United States Design Patent**
Teffenhart, Jr.

(10) **Patent No.:** **US D666,743 S**

(45) **Date of Patent:** **** Sep. 4, 2012**

(54) **SELF-MATING BEAM**

6,601,362 B1 8/2003 Prince

(Continued)

(76) Inventor: **Thomas Joseph Teffenhart, Jr.**,
Sarasota, FL (US)

Primary Examiner — Doris Clark

(74) *Attorney, Agent, or Firm* — Jacox, Meckstroth &
Jenkins

(**) Term: **14 Years**

(21) Appl. No.: **29/364,222**

(22) Filed: **Jun. 21, 2010**

(57) **CLAIM**

The ornamental design for self-mating beam, as shown and described.

Related U.S. Application Data

(60) Division of application No. 29/352,494, filed on Dec. 22, 2009, now Pat. No. Des. 620,618, which is a continuation-in-part of application No. 12/015,117, filed on Jan. 16, 2008, now Pat. No. 7,877,962.

(51) **LOC (9) Cl.** **25-01**

(52) **U.S. Cl.** **D25/124**

(58) **Field of Classification Search** D25/119,
D25/123, 124; 52/843, 844, 845, 849, 831
See application file for complete search history.

DESCRIPTION

FIG. 1 is a perspective view of a self-mating beam illustrating the mating of two extrusions;

FIG. 2 is an end view showing the assembly of the embodiment shown in FIG. 1, the opposite end being a mirror image thereof;

FIG. 3 is a fragmentary right side view of the assembly of the embodiment shown in FIG. 2;

FIG. 4 is a fragmentary view showing the left side of the assembly of the embodiment shown in FIG. 2;

FIG. 5 is a fragmentary top view showing the assembly of the embodiment shown in FIG. 1;

FIG. 6 is a fragmentary bottom view showing the assembly of the embodiment shown in FIG. 1;

FIG. 7 is a fragmentary perspective view of another embodiment of the invention showing the assembly;

FIG. 8 is an end view showing the assembly of the embodiment shown in FIG. 7, the opposite end being a mirror image thereof;

FIG. 9 is a fragmentary right side view of the assembly of the embodiment shown in FIG. 7;

FIG. 10 is a fragmentary left side view showing the opposite side of the assembly of the embodiment shown in FIG. 7;

FIG. 11 is a fragmentary top view showing the assembly of the embodiment shown in FIG. 7; and,

FIG. 12 is a fragmentary bottom view showing the assembly of the embodiment shown in FIG. 7.

(56) **References Cited**

U.S. PATENT DOCUMENTS

1,997,876	A	4/1935	Sheldon	
3,143,165	A	8/1964	Lewis et al.	
3,222,841	A	12/1965	Lipof	
3,224,154	A	12/1965	Toti et al.	
3,332,197	A	7/1967	Hinkle	
3,382,639	A	5/1968	Smith et al.	
3,413,775	A	12/1968	Katz	
4,002,000	A	1/1977	Howard et al.	
4,057,941	A	11/1977	Schwartz	
4,774,790	A	10/1988	Hopper	
5,031,083	A	7/1991	Claesson	
5,090,164	A *	2/1992	Mische	52/90.1
D343,909	S	2/1994	Flynn	
5,464,302	A	11/1995	Menchetti	
D374,488	S *	10/1996	Wang	D25/124
5,813,641	A	9/1998	Baldwin	
D414,881	S	10/1999	Giese	
6,092,348	A	7/2000	Dombchik et al.	
6,357,196	B1	3/2002	McCombs	
6,385,941	B1	5/2002	Power, Jr. et al.	
6,405,504	B1	6/2002	Richardson	
6,430,888	B1	8/2002	Dombchik et al.	

1 Claim, 8 Drawing Sheets

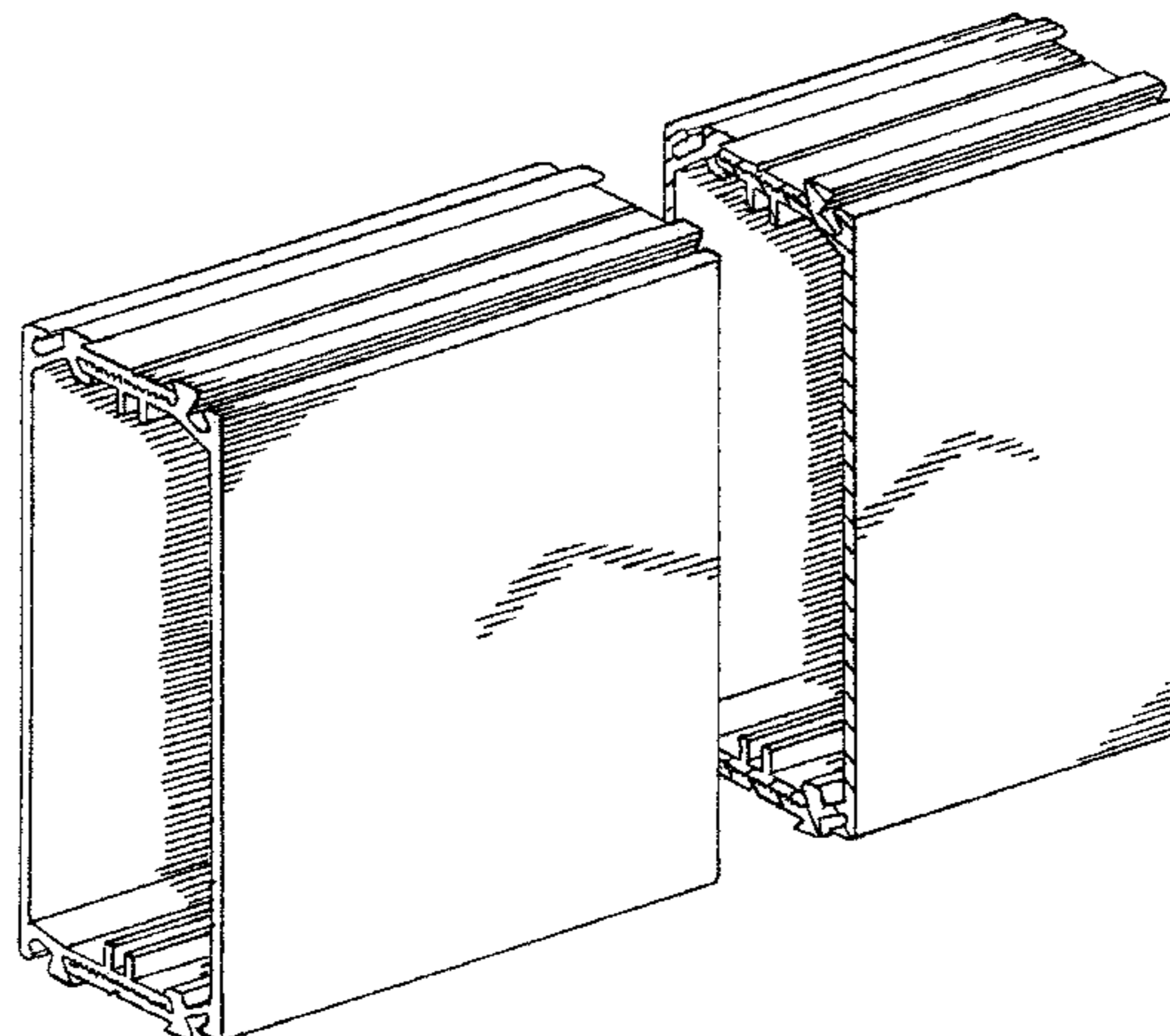

US D666,743 S

Page 2

U.S. PATENT DOCUMENTS

6,668,495	B1	12/2003	Prince	2002/0046539	A1*	4/2002	Schulz	52/730.4
6,755,004	B1	6/2004	Power, Jr. et al.	2007/0074480	A1	4/2007	Kleila et al.	
6,826,885	B2	12/2004	Raskin et al.	2007/0266671	A1	11/2007	Chromy	
D531,324	S	10/2006	Takagi	2008/0016816	A1	1/2008	Kim	
7,568,323	B2	8/2009	Shelton et al.	2008/0168738	A1	7/2008	Shelton et al.	

* cited by examiner

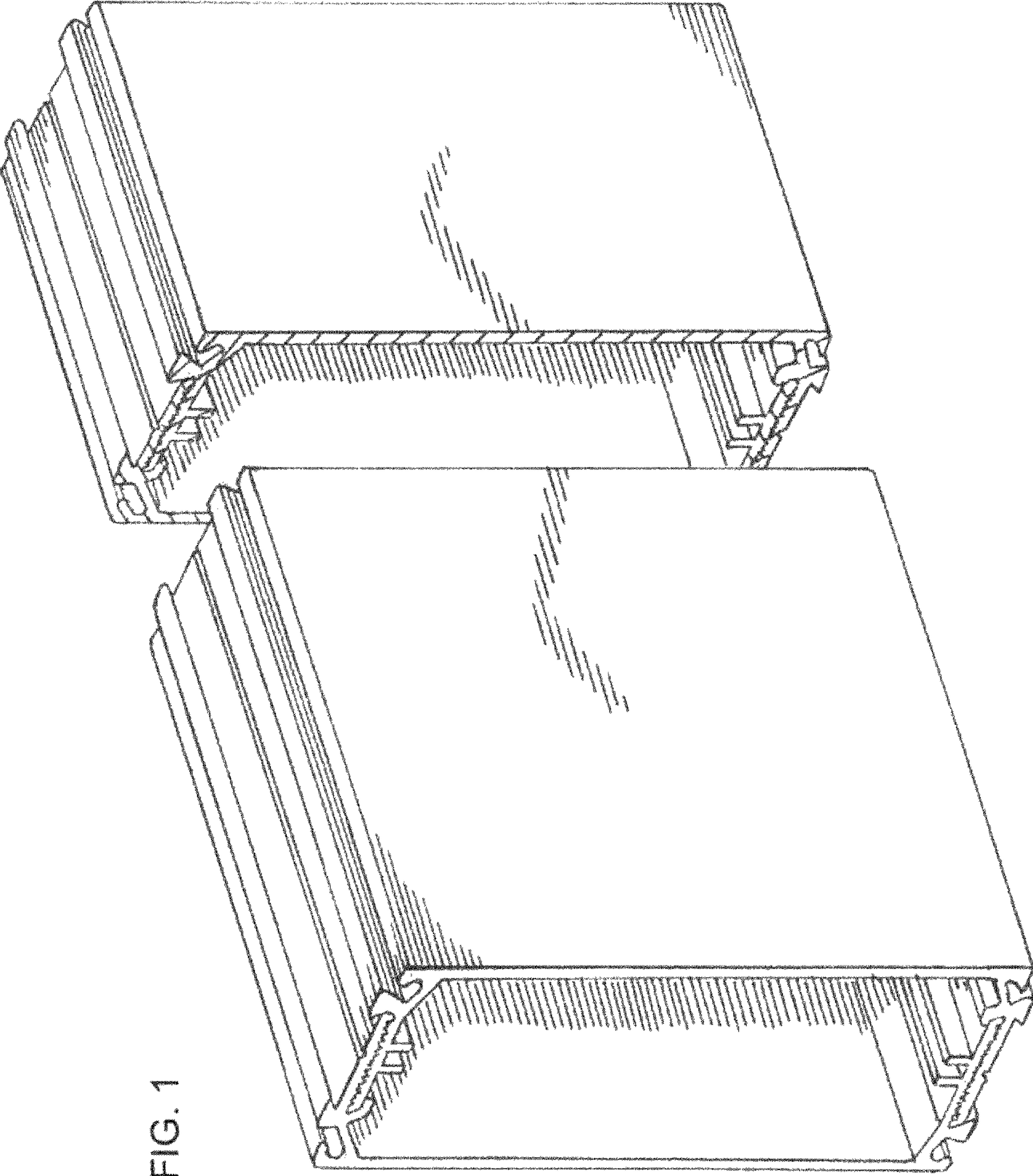

FIG. 1

FIG. 3

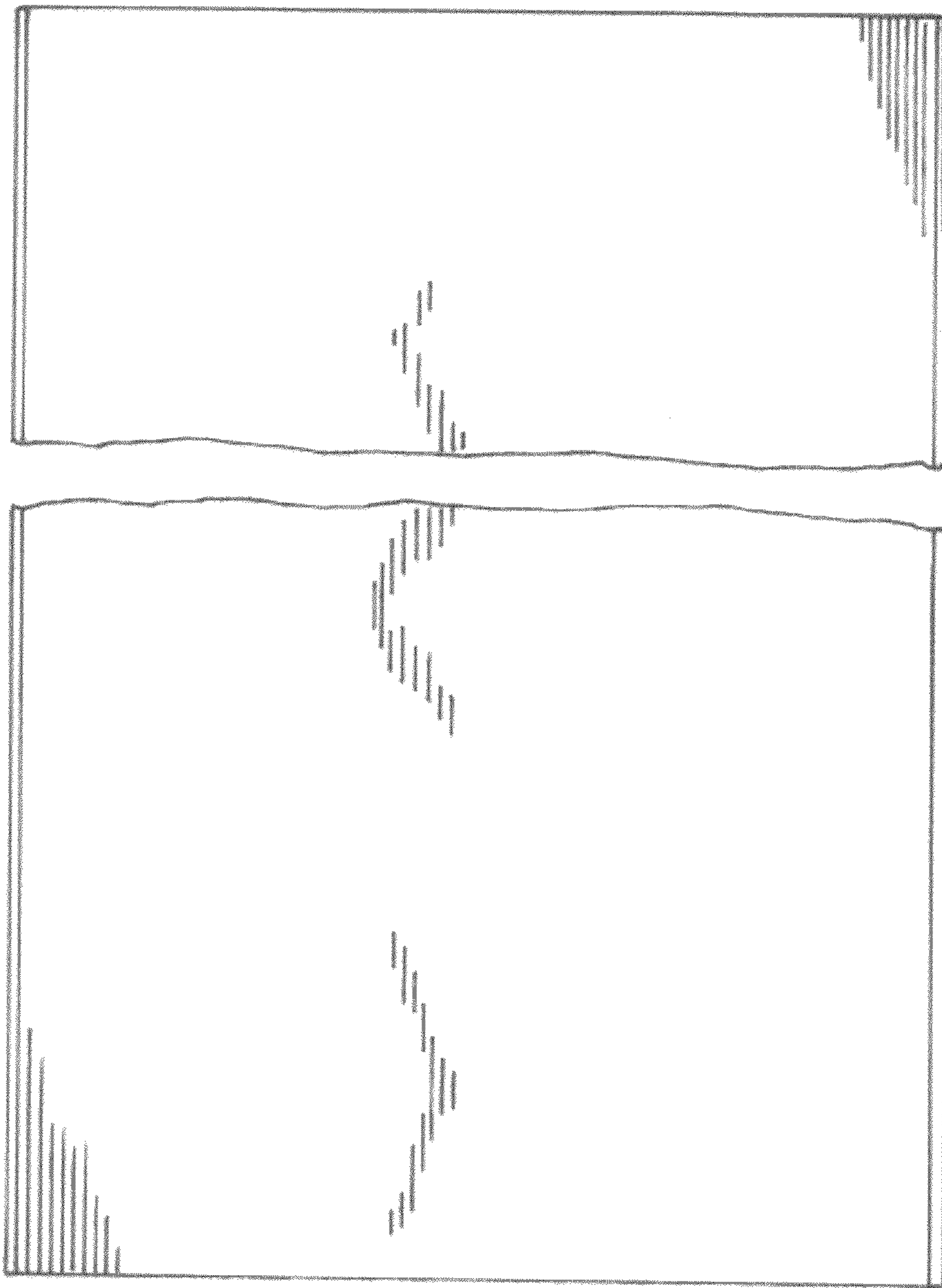
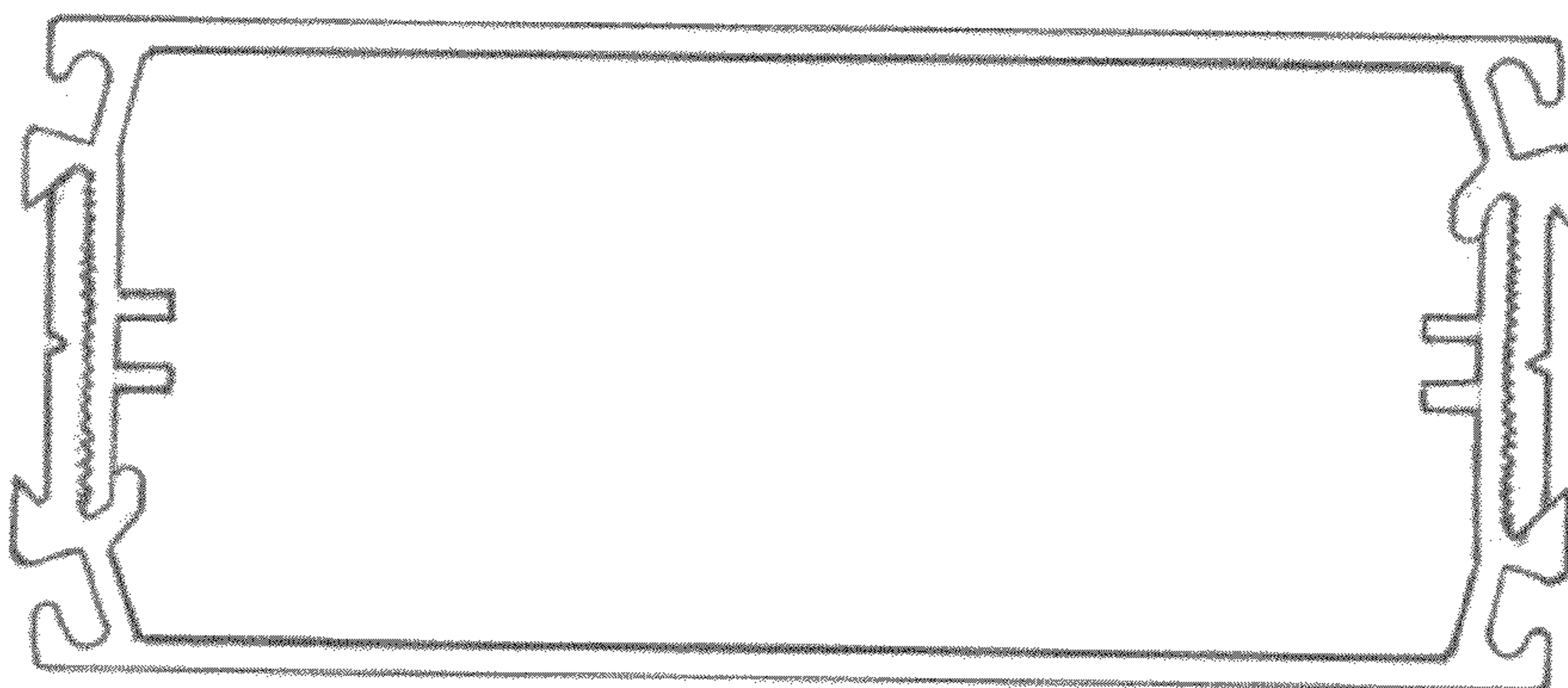

FIG. 2



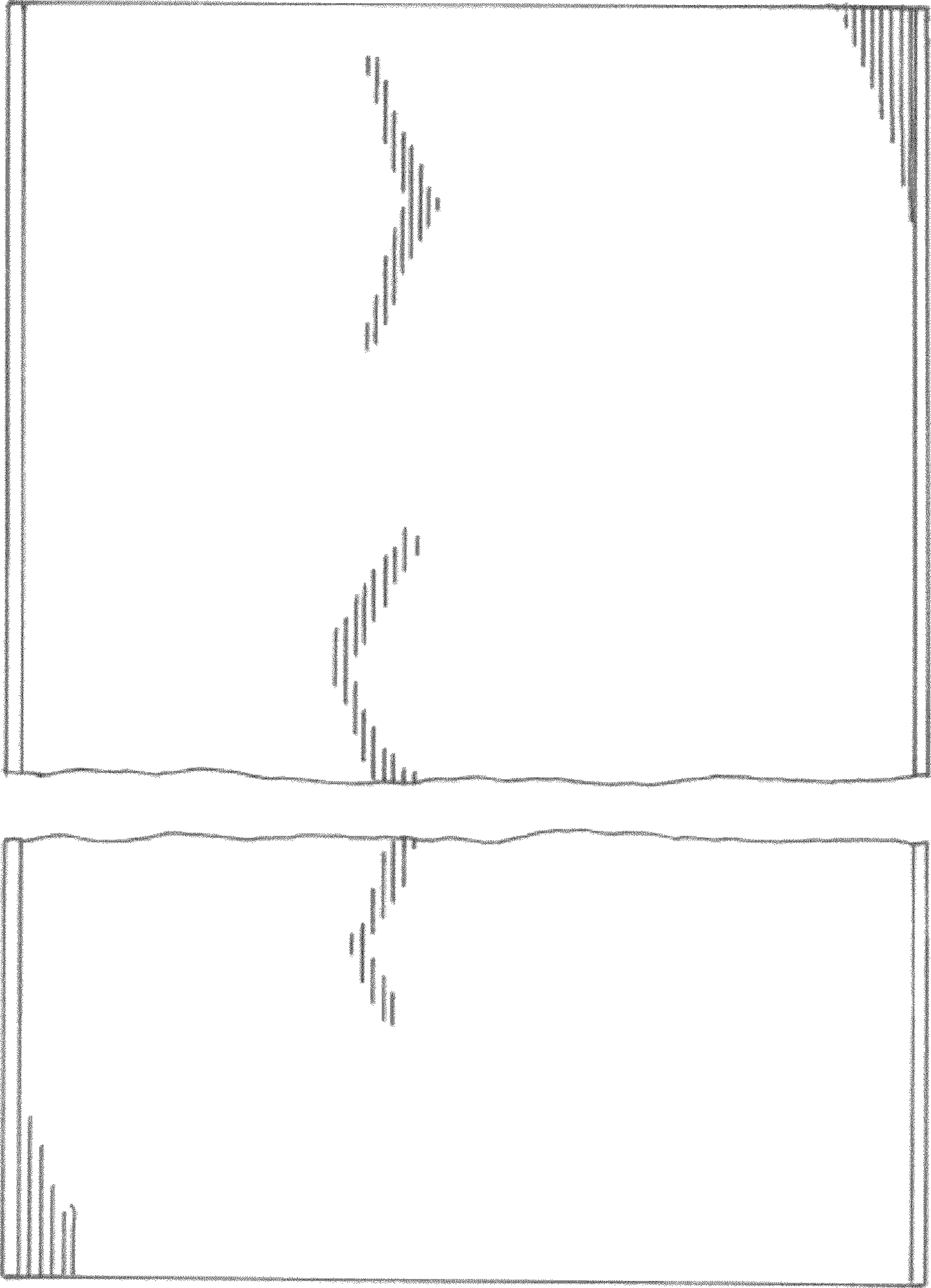

FIG. 4

FIG. 5

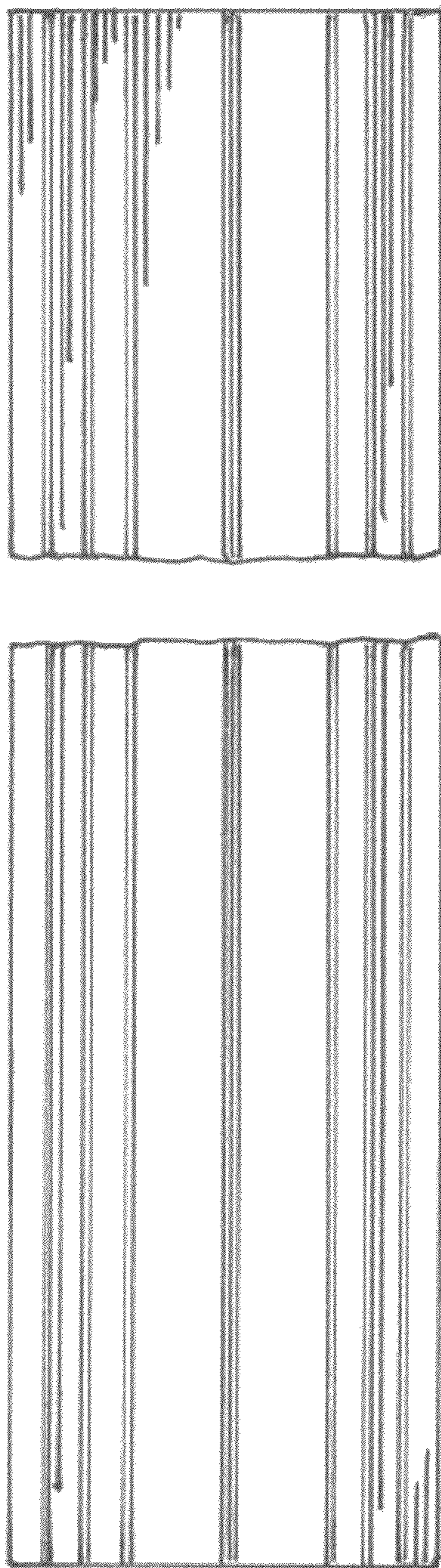
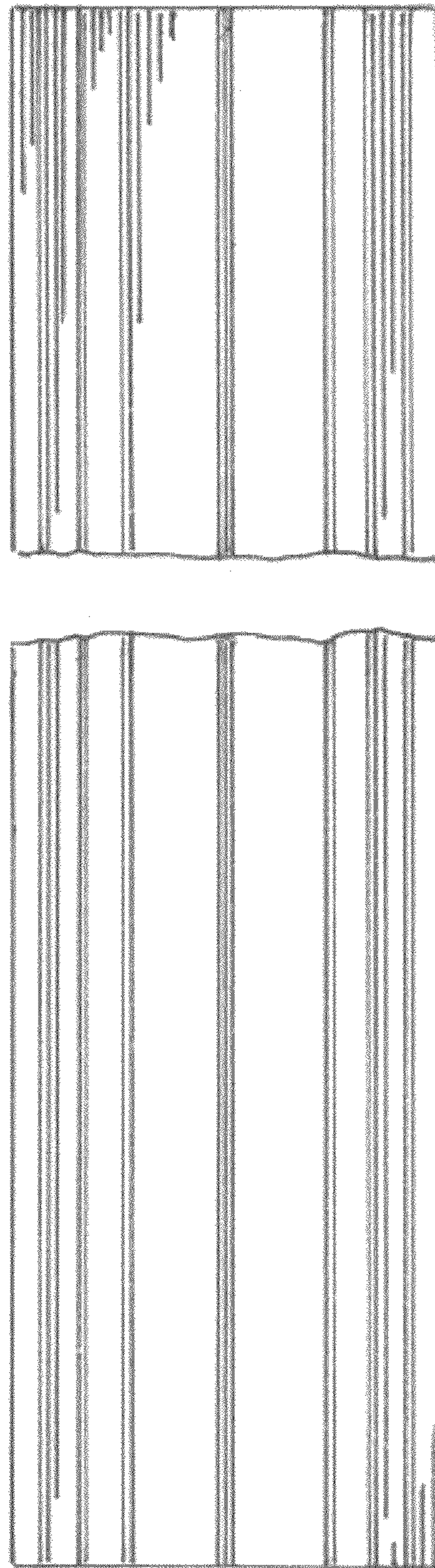

FIG. 6



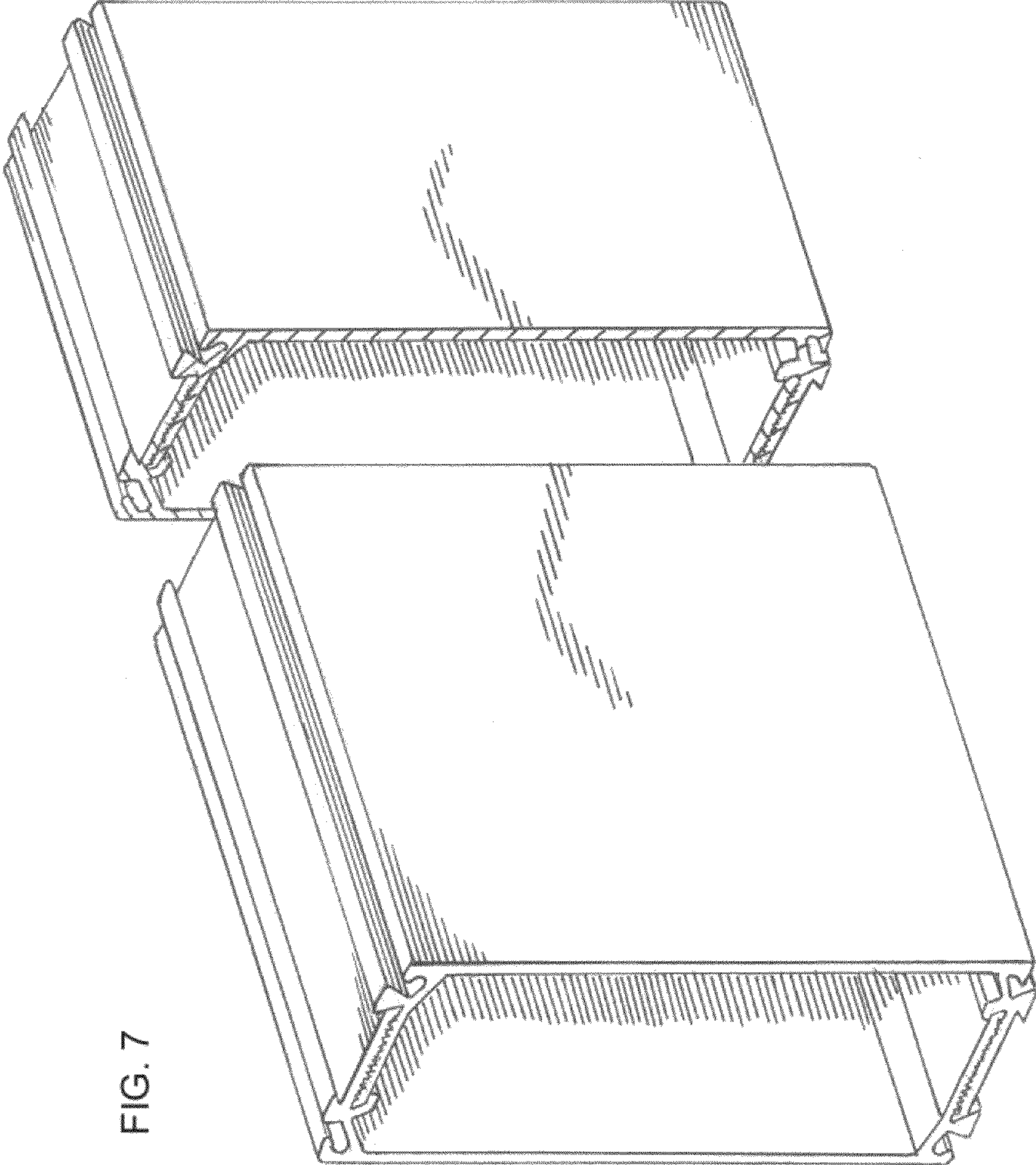

FIG. 7

FIG. 8

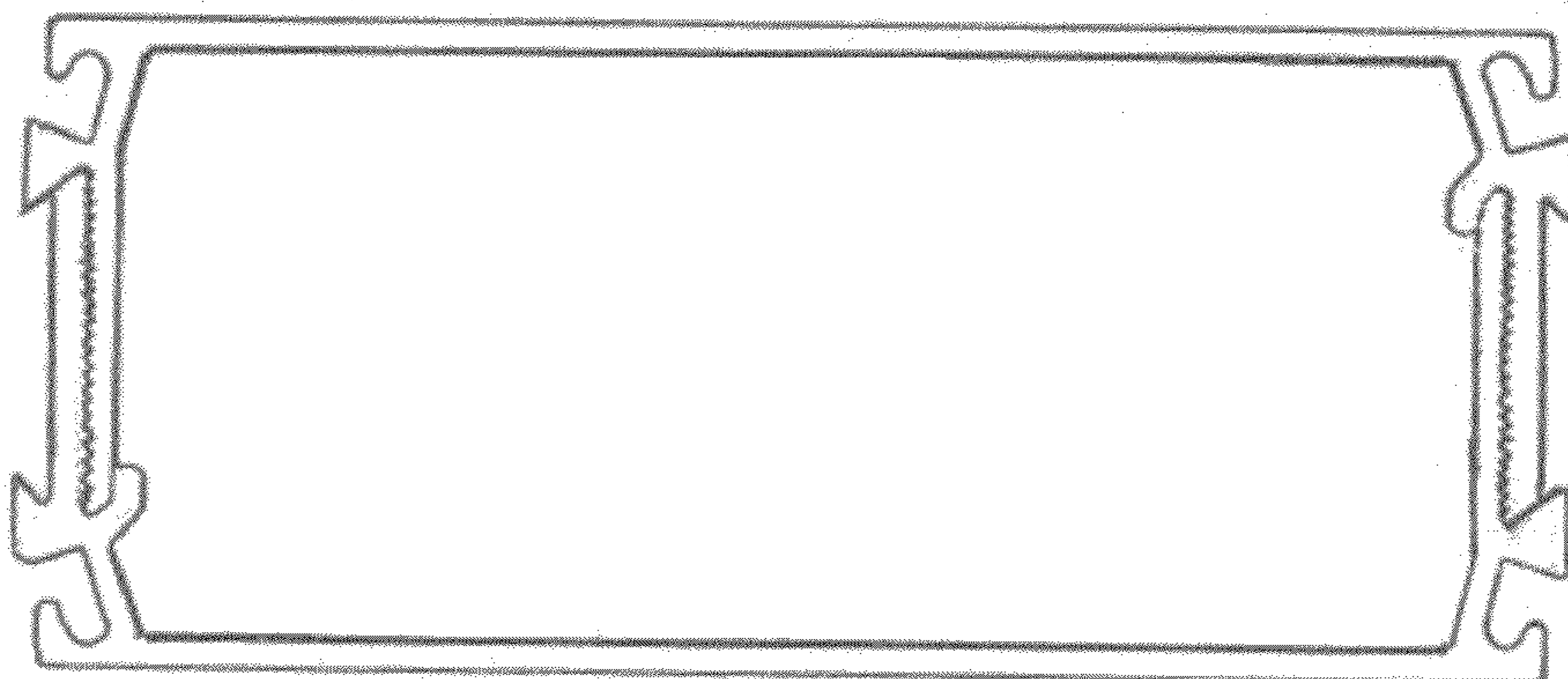
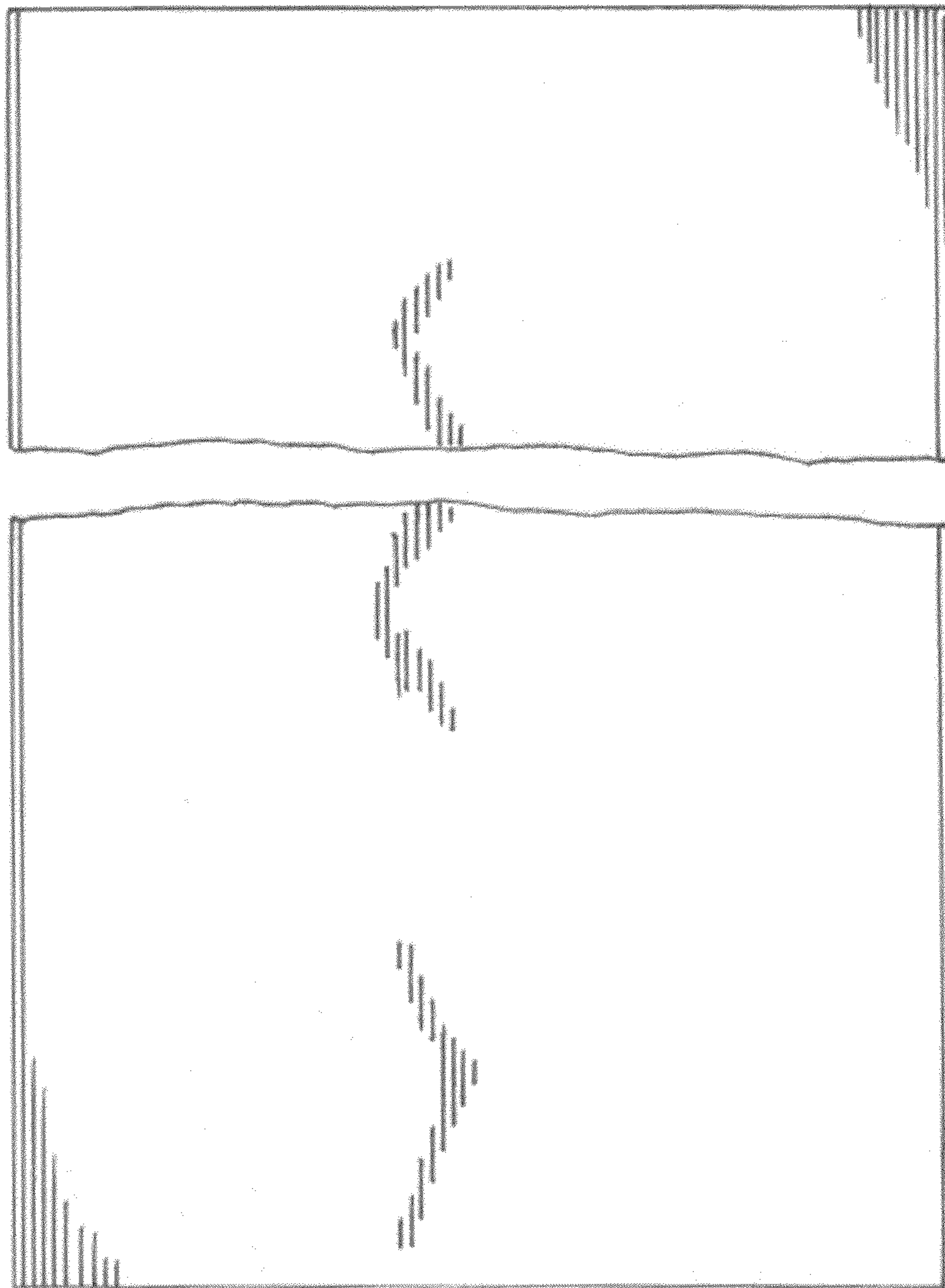

FIG. 9



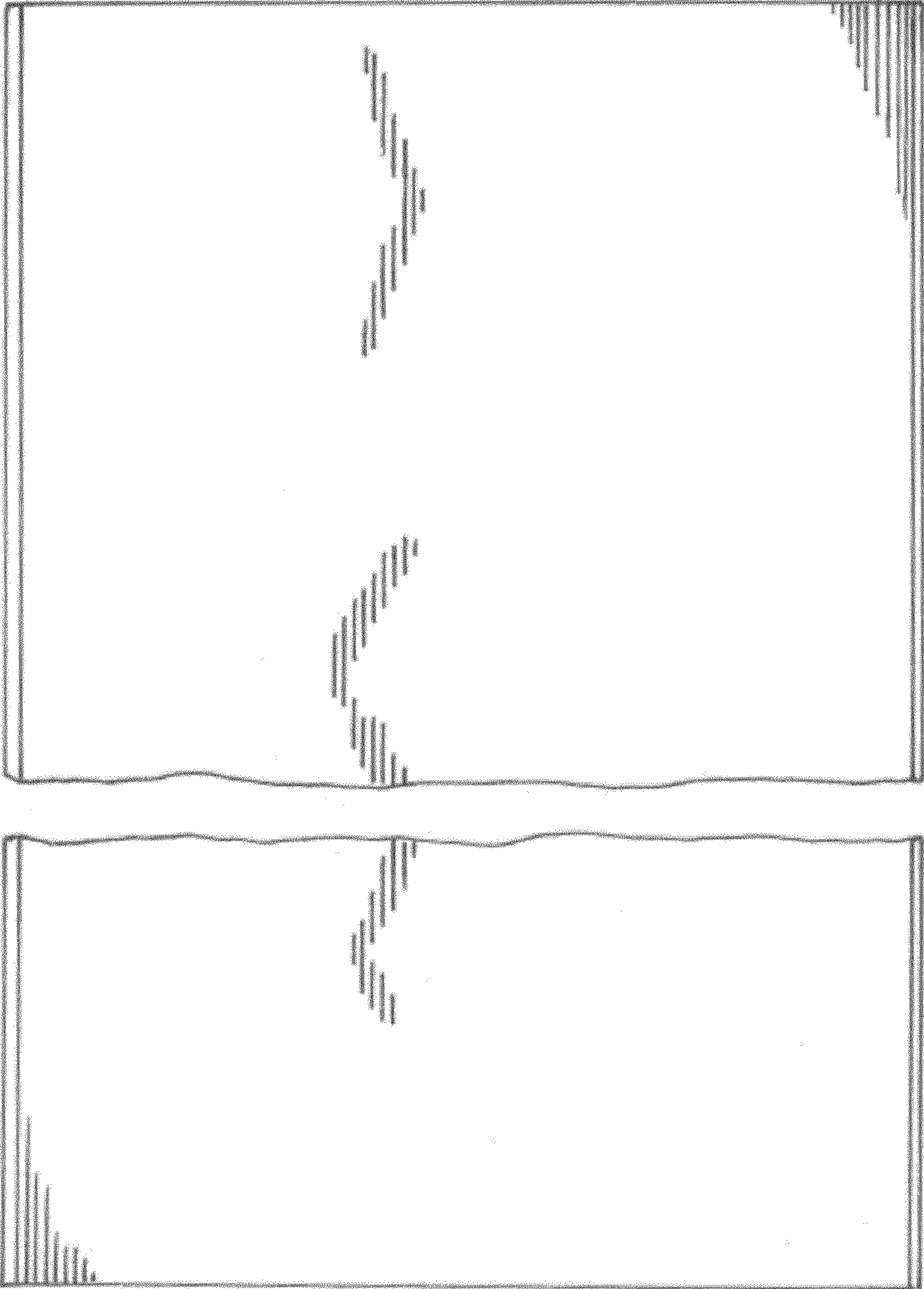

FIG. 10

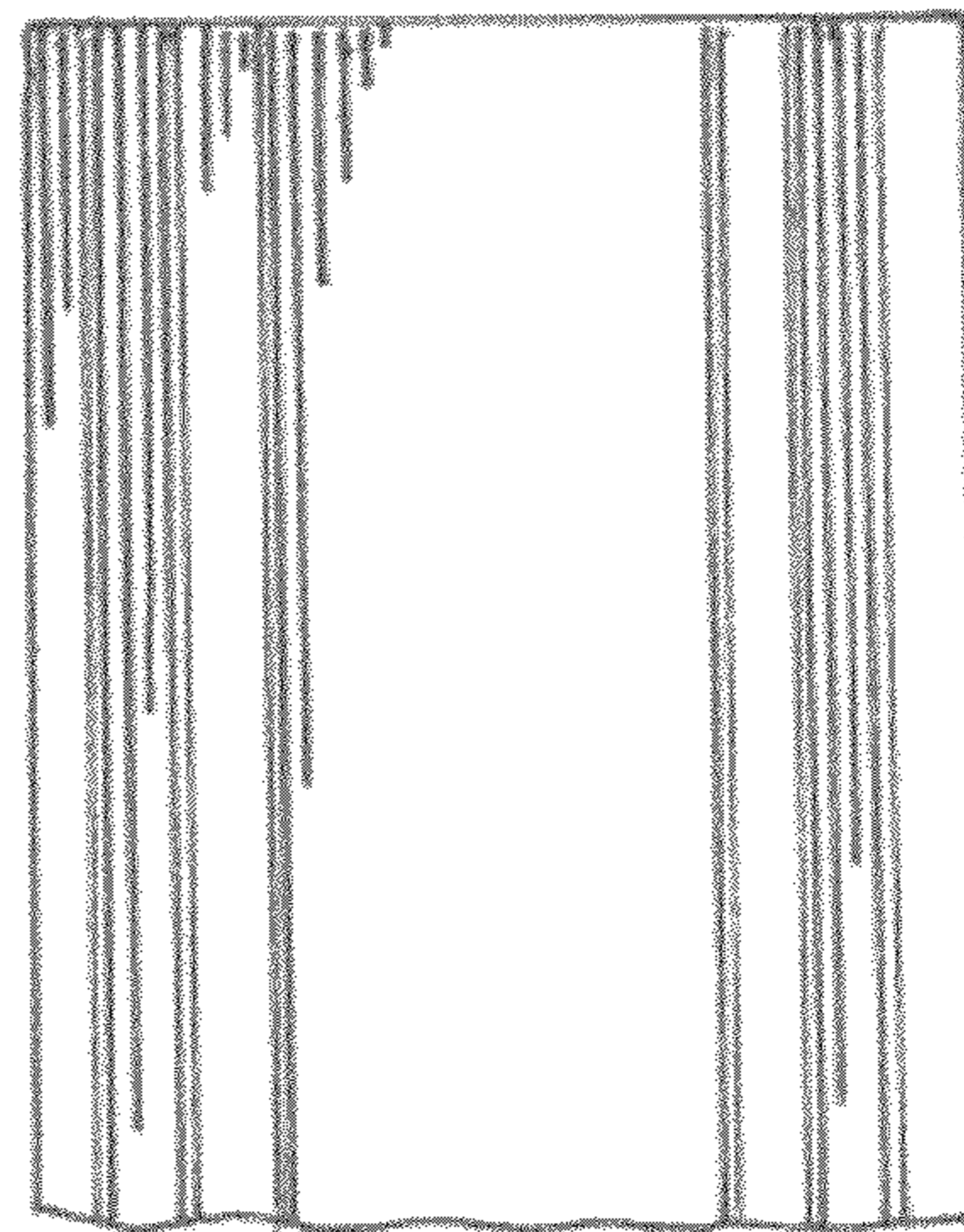
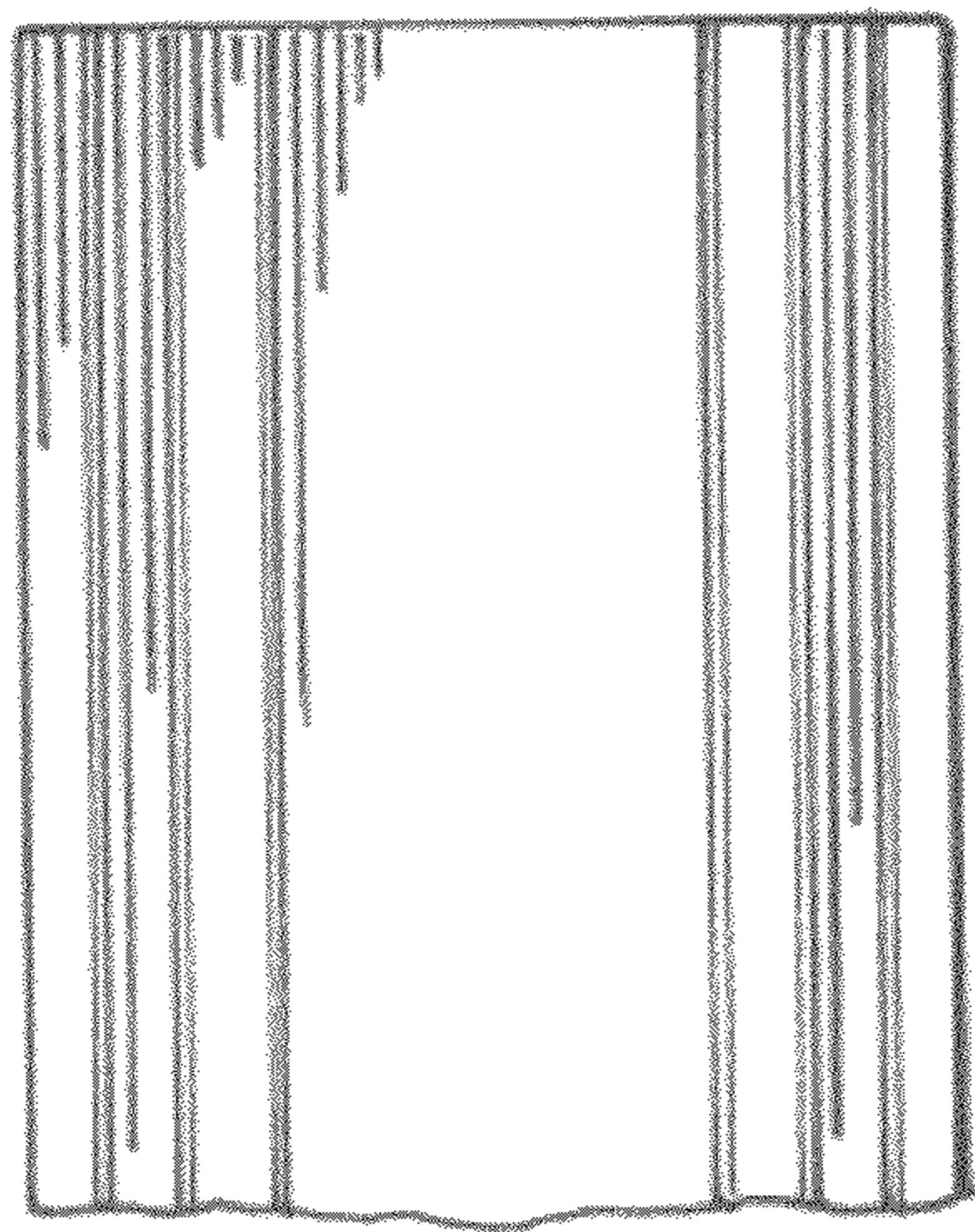

FIG. 11

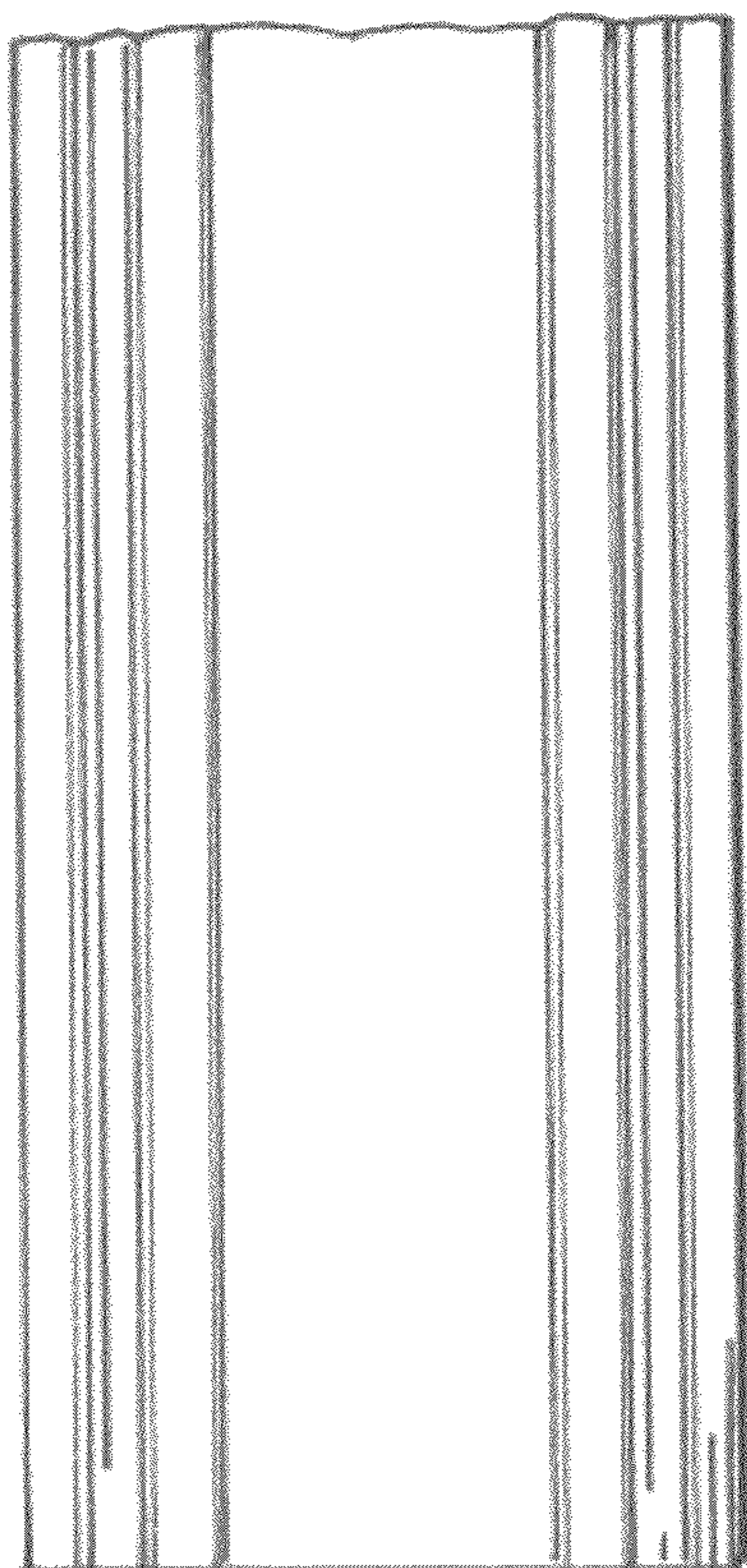

FIG. 12

