



US00D666477S

(12) **United States Design Patent**  
**Ito**

(10) **Patent No.:** **US D666,477 S**  
(45) **Date of Patent:** **\*\* Sep. 4, 2012**

(54) **CONNECTOR FOR CONSTRUCTIONAL MATERIALS**

(75) Inventor: **Hikomichi Ito**, Gifu-ken (JP)  
(73) Assignee: **Kabushiki Kaisha NCN**, Gifu-ken (JP)  
(\*\*) Term: **14 Years**  
(21) Appl. No.: **29/387,026**  
(22) Filed: **Mar. 8, 2011**

(30) **Foreign Application Priority Data**

Nov. 3, 2010 (CN) ..... 2010 3 0590918

(51) **LOC (9) Cl.** ..... **08-05**  
(52) **U.S. Cl.** ..... **D8/373**  
(58) **Field of Classification Search** ..... D8/381,  
D8/380, 373, 371, 366, 363, 354, 349; D6/572,  
D6/567, 553, 512, 491, 466, 449, 418, 407;  
52/12, 11; 248/917, 629, 309.1, 300, 261,  
248/250, 245, 239, 235, 200; 211/88.1, 90.01  
See application file for complete search history.

(56) **References Cited**

**U.S. PATENT DOCUMENTS**

1,972,108	A *	9/1934	Richardson	.....	5/296
2,648,074	A *	8/1953	Jonas	.....	5/296
2,666,214	A *	1/1954	Harris	.....	5/288
2,947,999	A *	8/1960	Hooker	.....	5/286
4,148,106	A *	4/1979	Gallien	.....	5/296
4,387,872	A *	6/1983	Hogue	.....	248/221.11
5,975,318	A *	11/1999	Jay	.....	211/90.01
7,007,321	B2 *	3/2006	Polevoy et al.	.....	5/288
D547,163	S *	7/2007	Xayoiphonh	.....	D8/363
D550,540	S *	9/2007	Nawrocki	.....	D8/354
2005/0217027	A1 *	10/2005	Polevoy et al.	.....	5/201

**FOREIGN PATENT DOCUMENTS**

JP	899148	5/1994
JP	899148-1	2/2000
JP	899148-2	2/2000
JP	899148-3	2/2000
JP	899148-4	2/2000
JP	1161707	12/2002
JP	1161999	12/2002
JP	1162000	12/2002
JP	1162001	12/2002

\* cited by examiner

*Primary Examiner* — Robert M Spear

*Assistant Examiner* — Rashida C McCoy

(74) *Attorney, Agent, or Firm* — Fish & Richardson P.C.

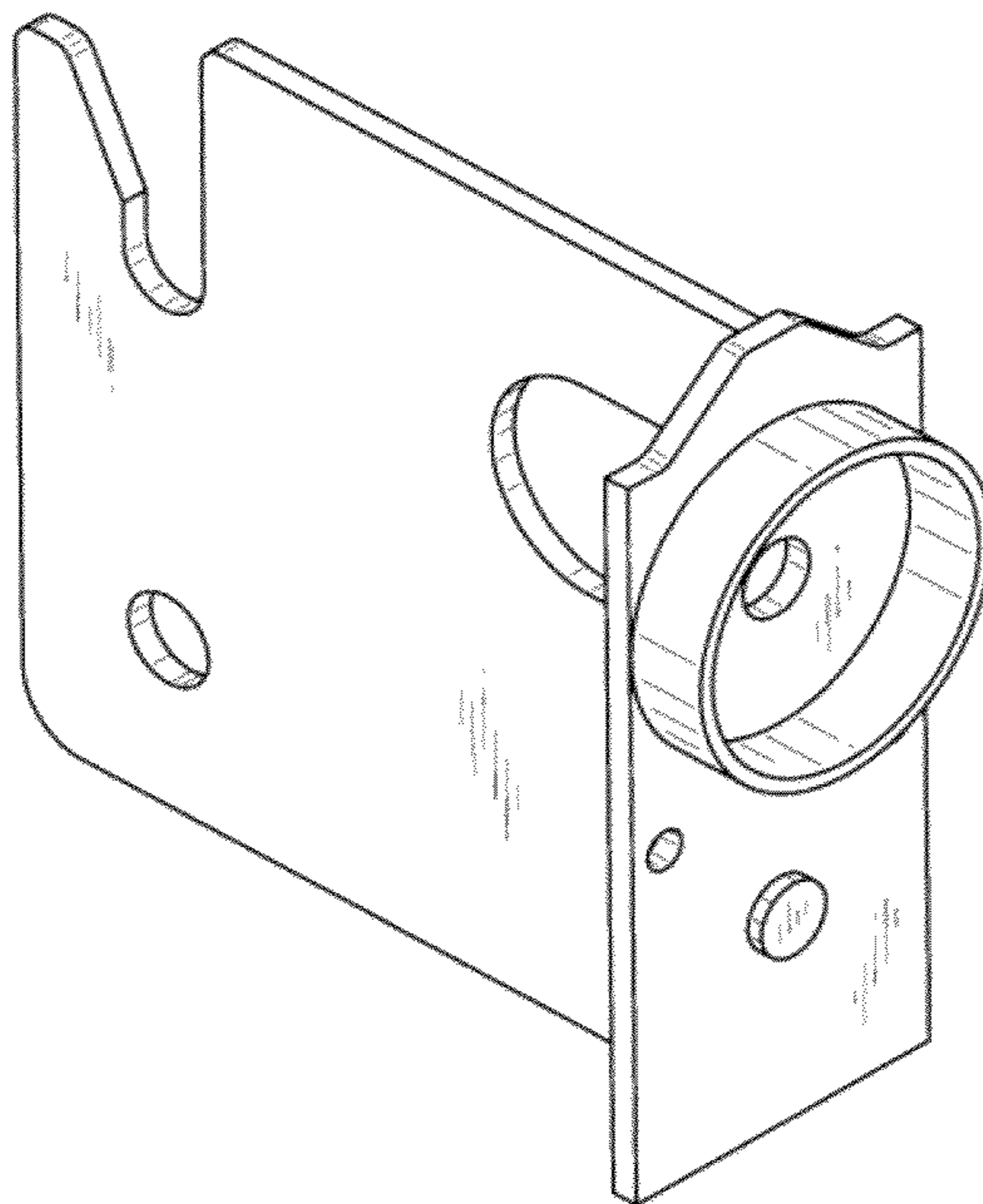
(57) **CLAIM**

The ornamental design for a connector for constructional materials, as shown and described.

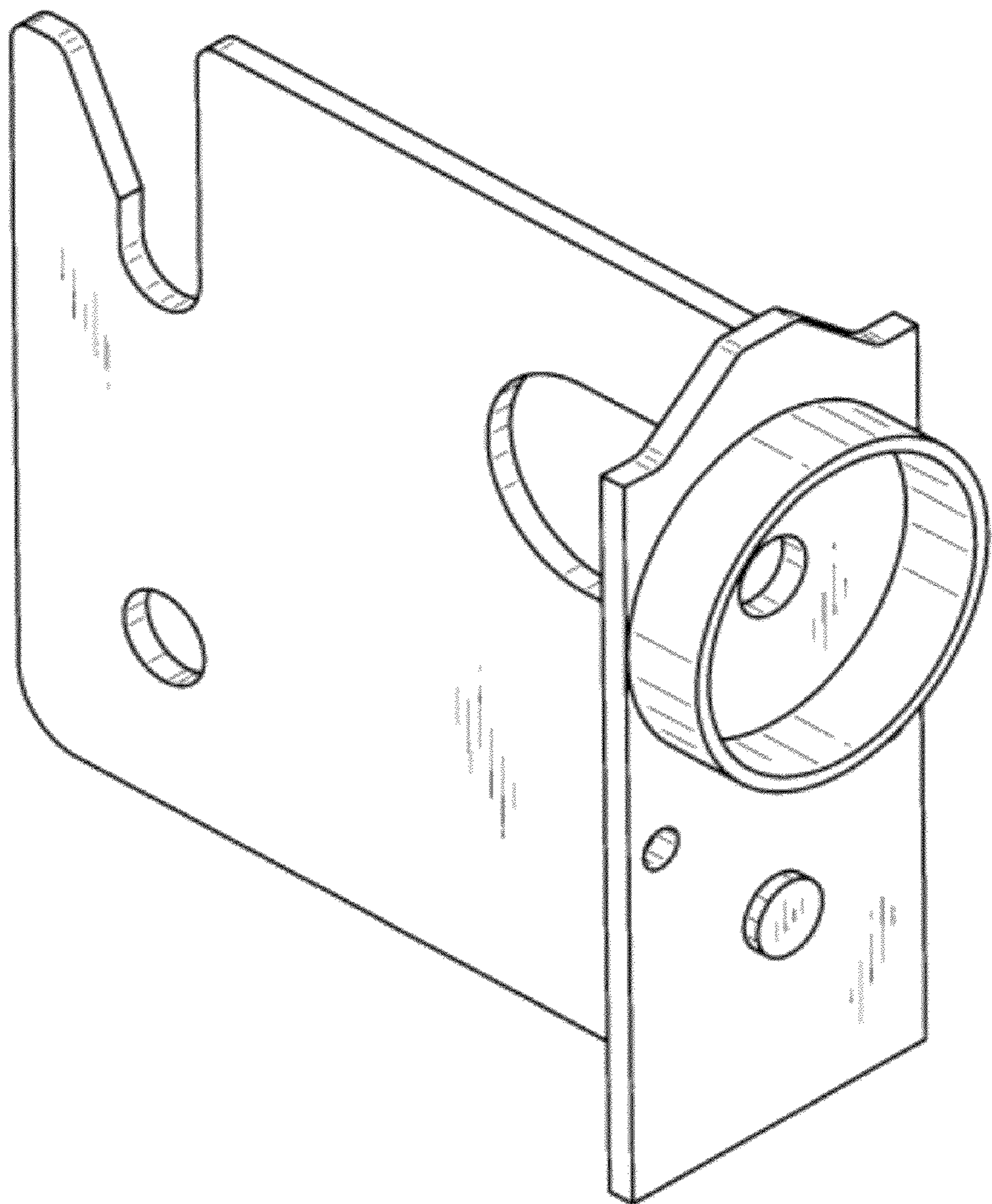
**DESCRIPTION**

FIG. 1 is a perspective view of a connector for constructional materials showing my new design;  
FIG. 2 is a front view thereof;  
FIG. 3 is a rear view thereof;  
FIG. 4 is a top plan view thereof;  
FIG. 5 is a bottom plan view thereof;  
FIG. 6 is a right side view thereof, the left side view being a mirror image of FIG. 6;  
FIG. 7 is a cross-sectional view taken along line 7-7 in FIG. 2;  
and,  
FIG. 8 is a referential view showing the article in use.  
The features shown in broken lines in FIG. 8 depict environmental subject matter only and form no part of the claimed design.

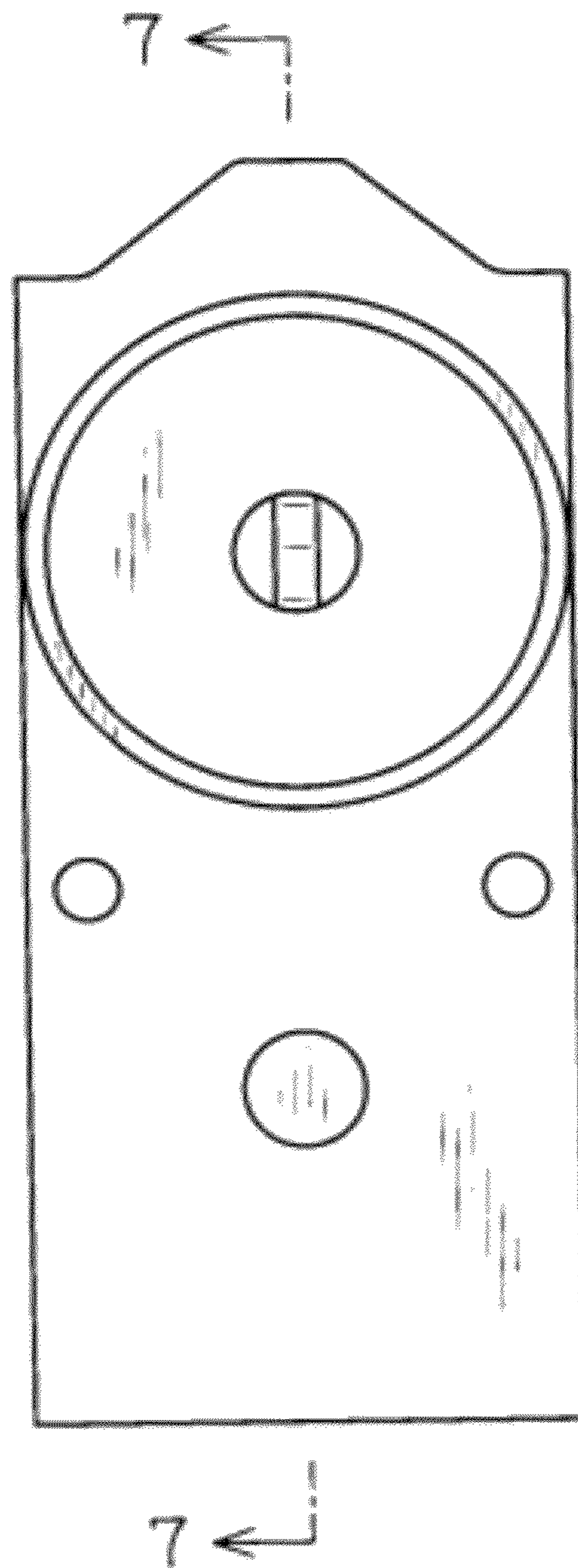
**1 Claim, 8 Drawing Sheets**



**Fig. 1**

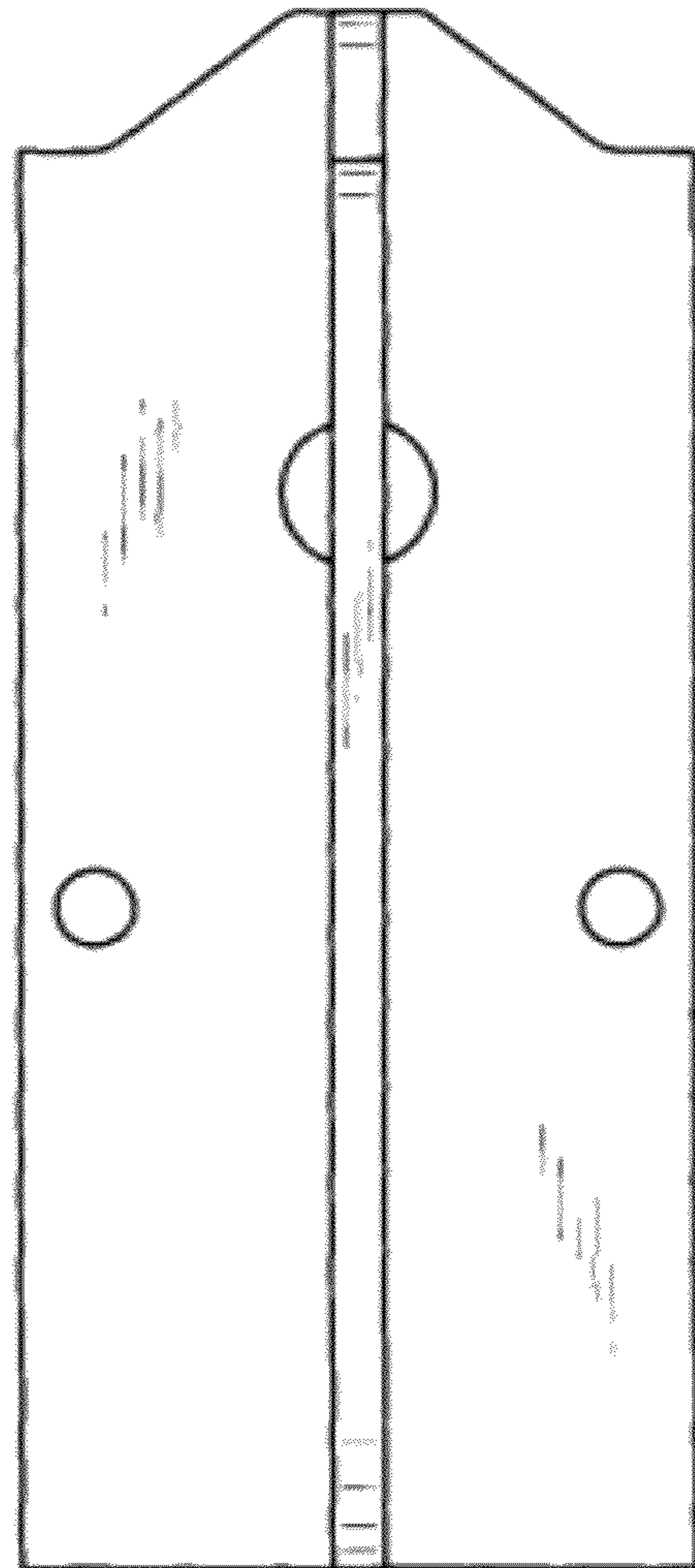


**Fig. 2**

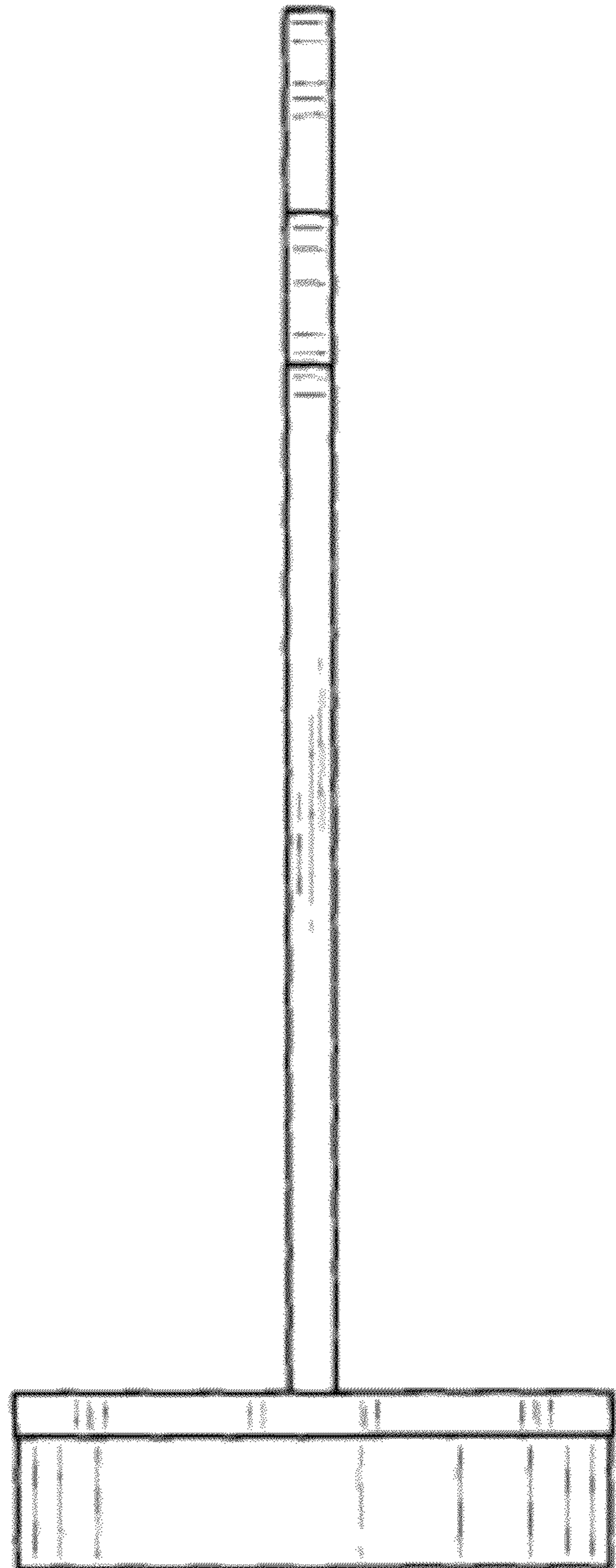




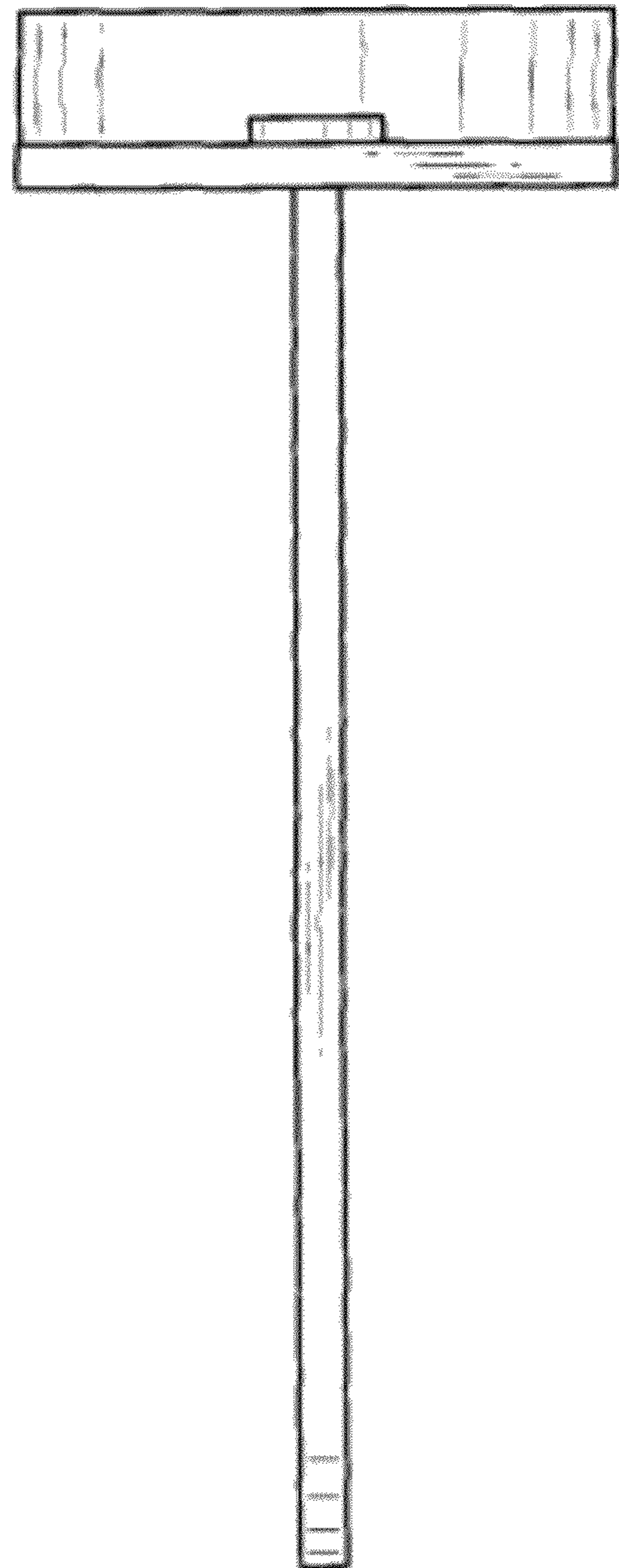
**Fig. 3**



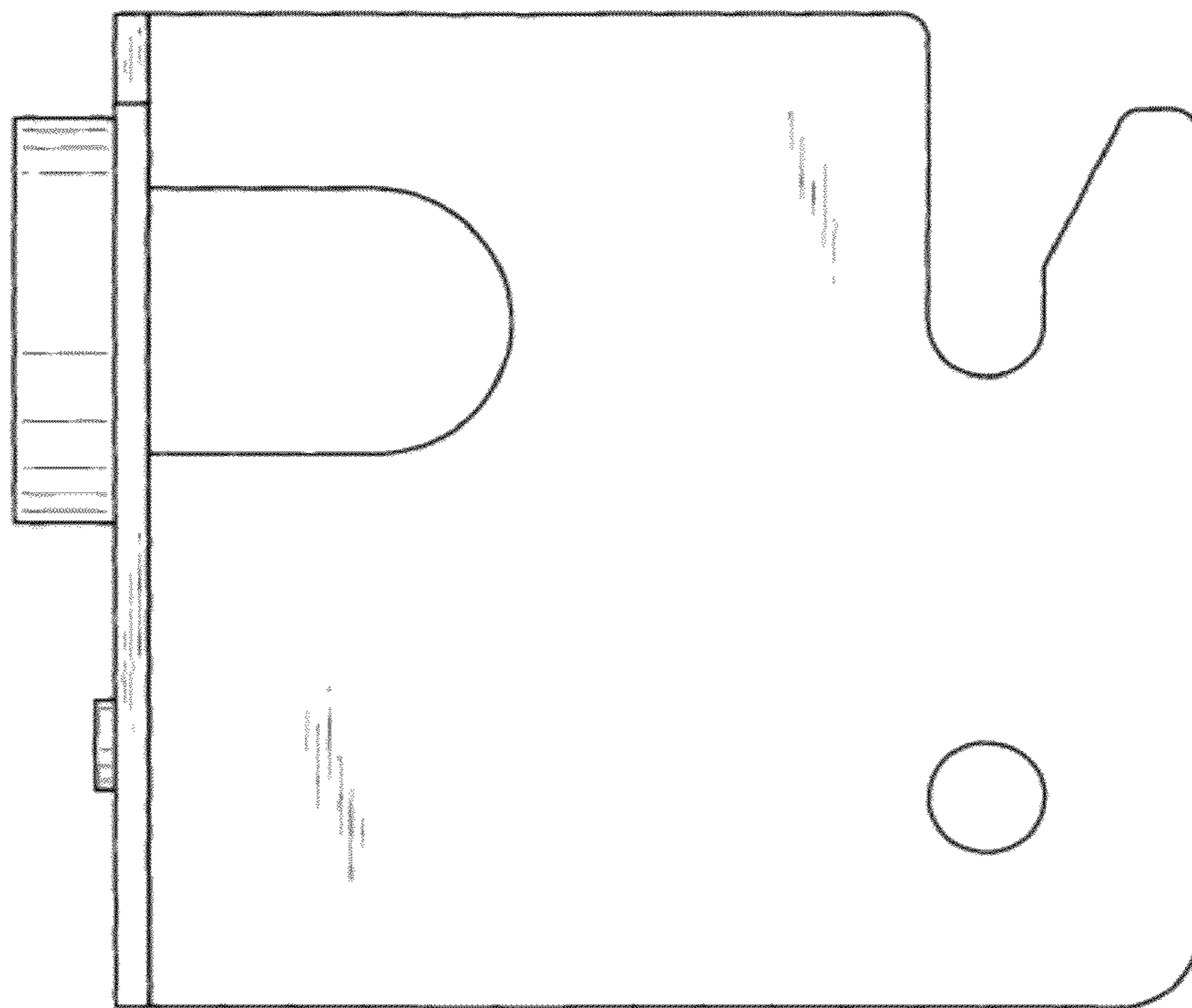
**Fig. 4**



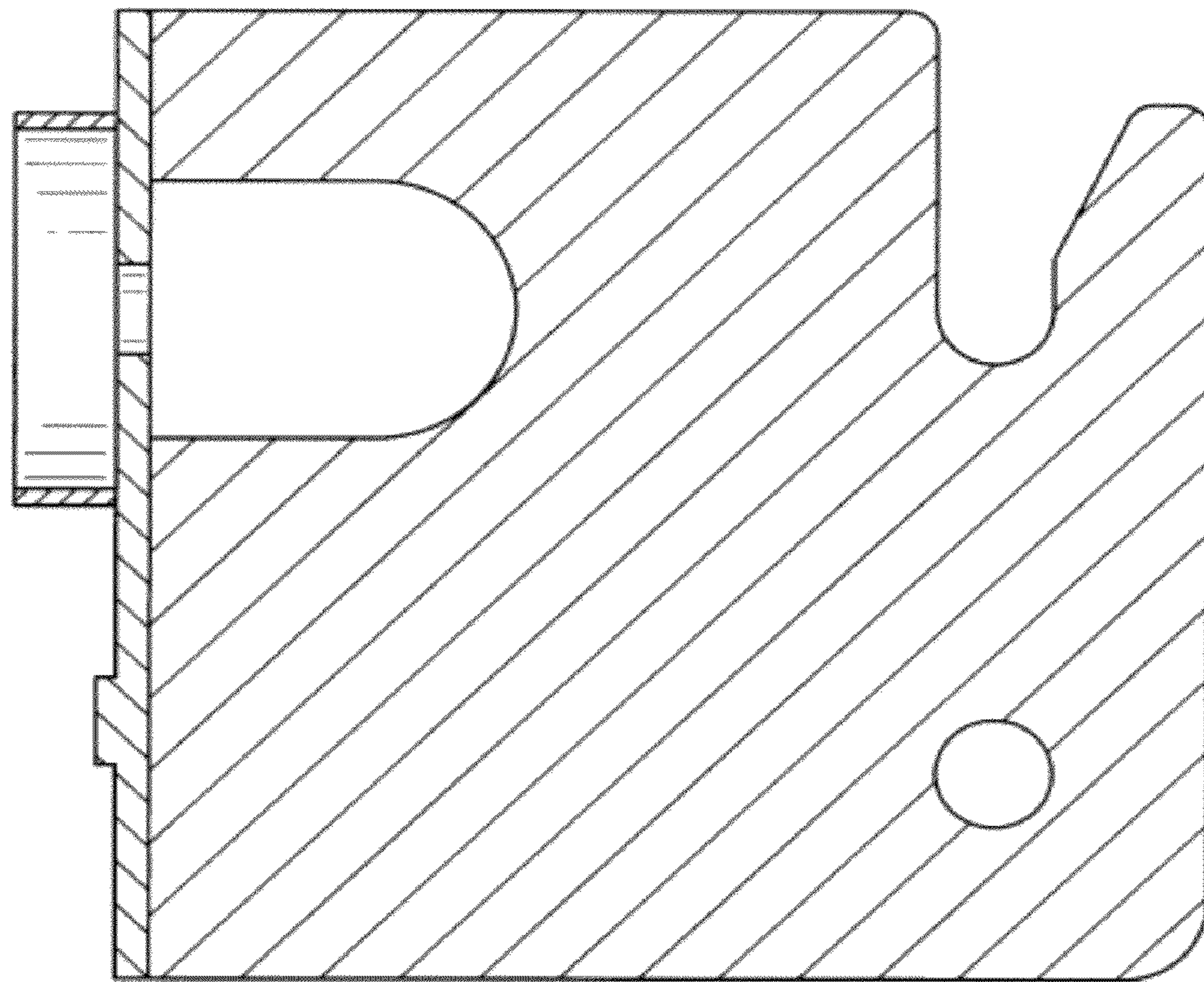
# Fig. 5



**Fig. 6**



**Fig. 7**





**Fig. 8**

