

US00D666224S

(12) **United States Design Patent**
Pruszynski et al.

(10) **Patent No.:** **US D666,224 S**
(45) **Date of Patent:** **** Aug. 28, 2012**

(54) **REFRIGERANT RECOVERY UNIT**
(75) Inventors: **Michael Pruszynski**, Hialeah, FL (US);
Richard Koldewey, Auburn, IN (US);
Juan Saluzzio, Miami, FL (US)
(73) Assignee: **CPS Products, Inc.**, Ft. Lauderdale, FL
(US)

D549,744 S * 8/2007 Sundheim et al. D15/79
D573,159 S 7/2008 Etter
D604,746 S 11/2009 Nishido et al.
D630,229 S 1/2011 Dreifert
7,878,081 B2 * 2/2011 Sundheim 74/50
D649,600 S * 11/2011 Opsahl D15/79
2010/0154442 A1 * 6/2010 Schoenoff et al. 62/77
2011/0132018 A1 * 6/2011 Chang 62/298
* cited by examiner

(**) Term: **14 Years**
(21) Appl. No.: **29/402,839**
(22) Filed: **Sep. 28, 2011**

Primary Examiner — Mitchell Siegel
(74) *Attorney, Agent, or Firm* — Malin Haley DiMaggio
Bowen & Lhota, P.A.

(51) **LOC (9) Cl.** **15-07**
(52) **U.S. Cl.** **D15/79**
(58) **Field of Classification Search** D15/79;
74/50; 312/3.6, 116, 138.1, 236, 400-409;
62/125, 126, 77, 292, 298, 336
See application file for complete search history.

(57) **CLAIM**
The ornamental design for a refrigerant recovery unit, as
shown and described.

DESCRIPTION

FIG. 1 is a perspective view of the refrigerant recovery unit,
showing the new design;
FIG. 2 is a right side elevation view of the refrigerant recovery
unit;
FIG. 3 is a left side elevation view of the refrigerant recovery
unit;
FIG. 4 is a front elevation view of the refrigerant recovery
unit;
FIG. 5 is a rear elevation view of the refrigerant recovery unit;
FIG. 6 is a top elevation view of the refrigerant recovery unit;
and,
FIG. 7 is a bottom elevation view of the refrigerant recovery
unit.

(56) **References Cited**
U.S. PATENT DOCUMENTS
4,631,006 A 12/1986 Murray
5,189,881 A * 3/1993 Miles 62/77
D344,527 S * 2/1994 Drago et al. D15/79
5,313,808 A * 5/1994 Scuderi 62/292
D377,179 S * 1/1997 Sundheim et al. D15/79
D474,209 S * 5/2003 Seymour et al. D15/79
D482,373 S * 11/2003 Seymour et al. D15/79
D536,711 S * 2/2007 Sundheim et al. D15/79

1 Claim, 6 Drawing Sheets

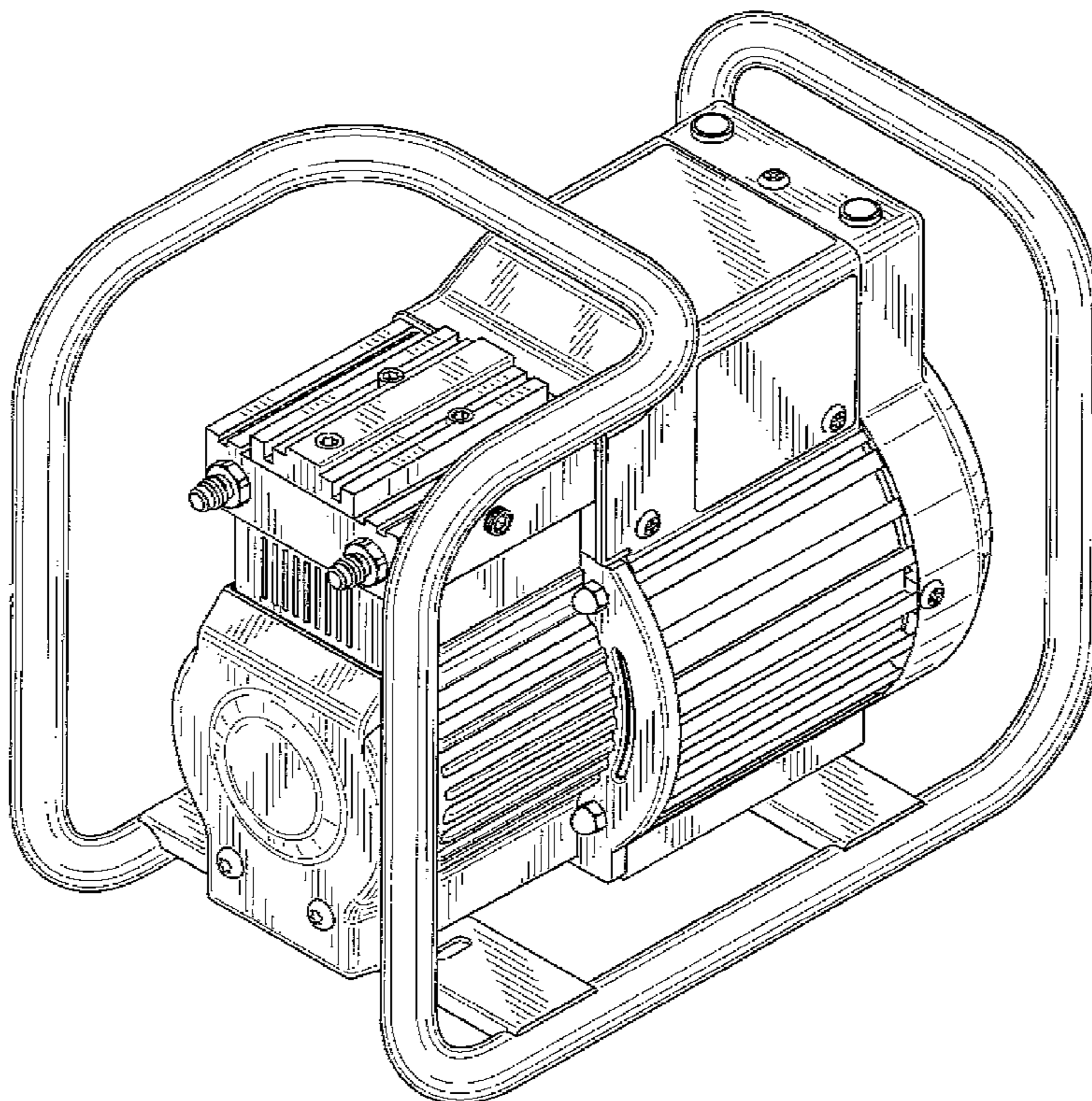

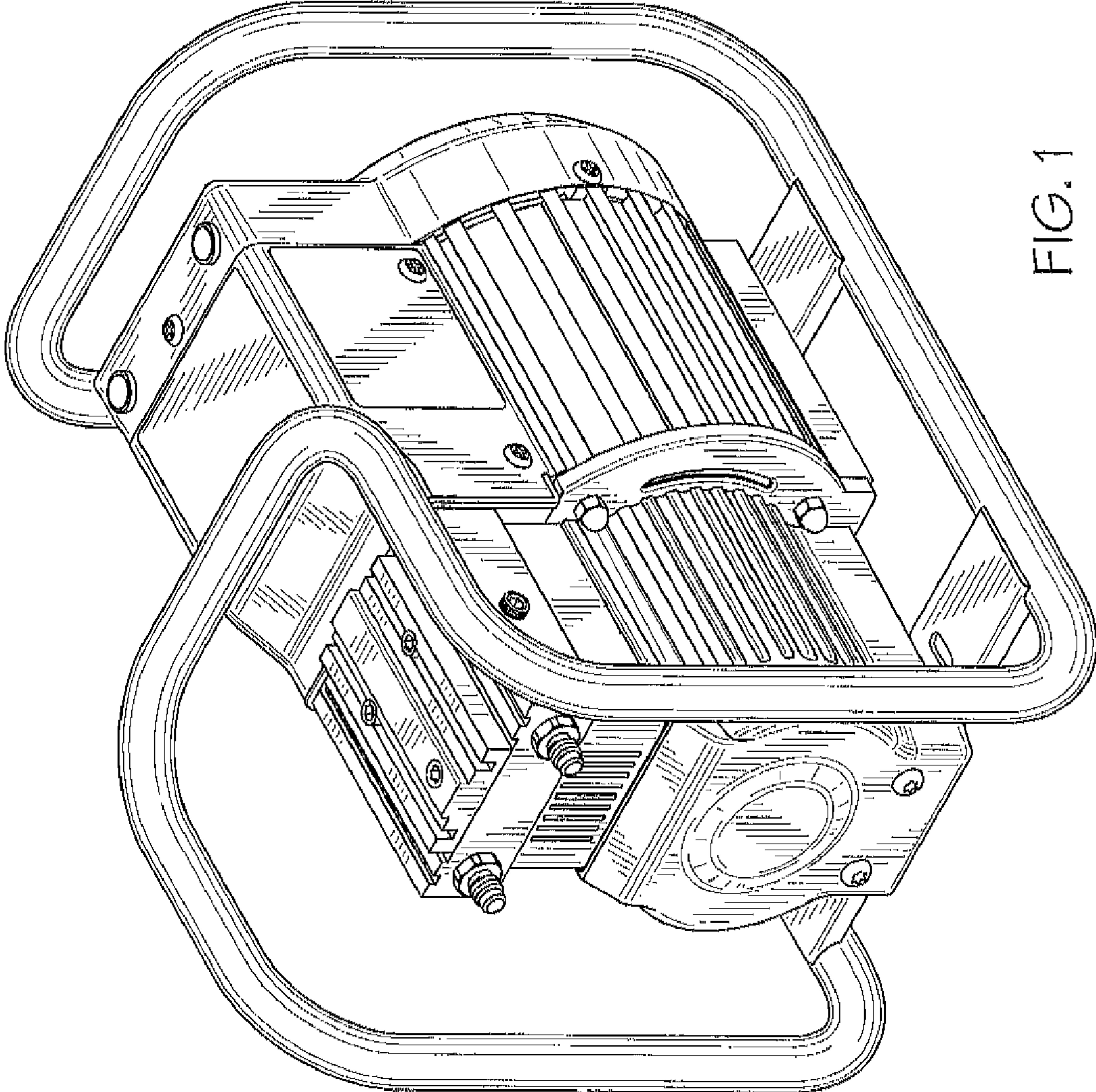

FIG. 1

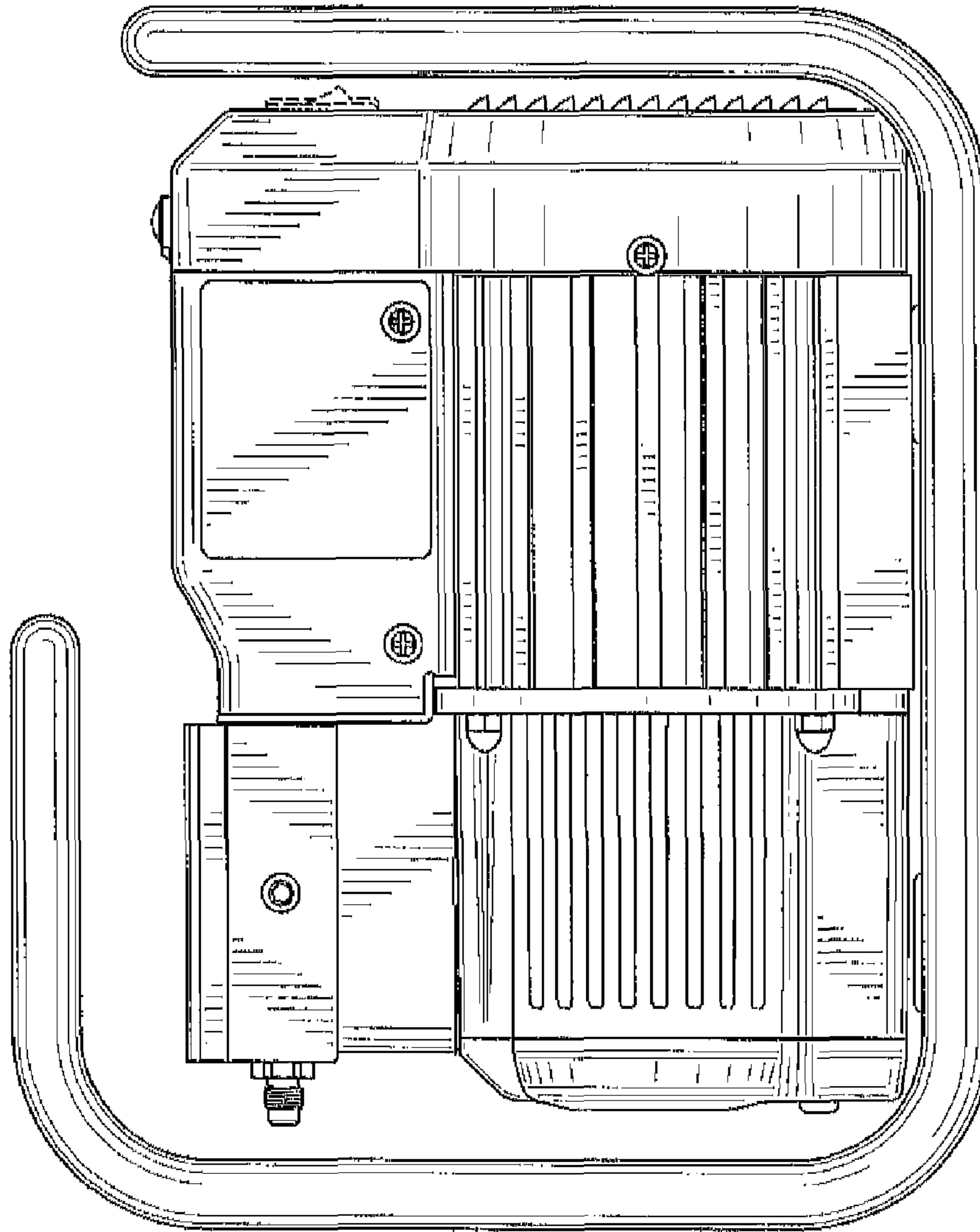

FIG. 2

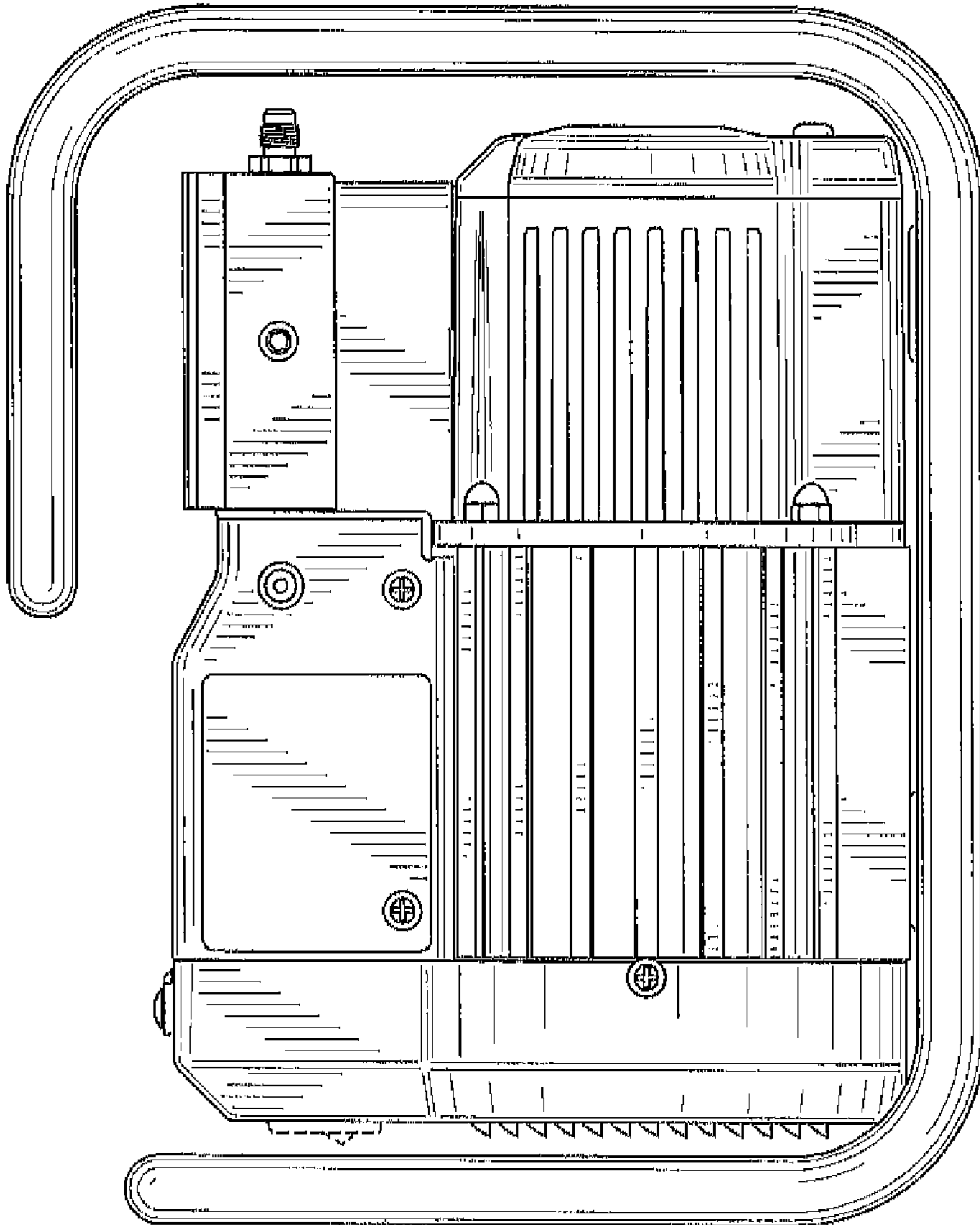

FIG. 3

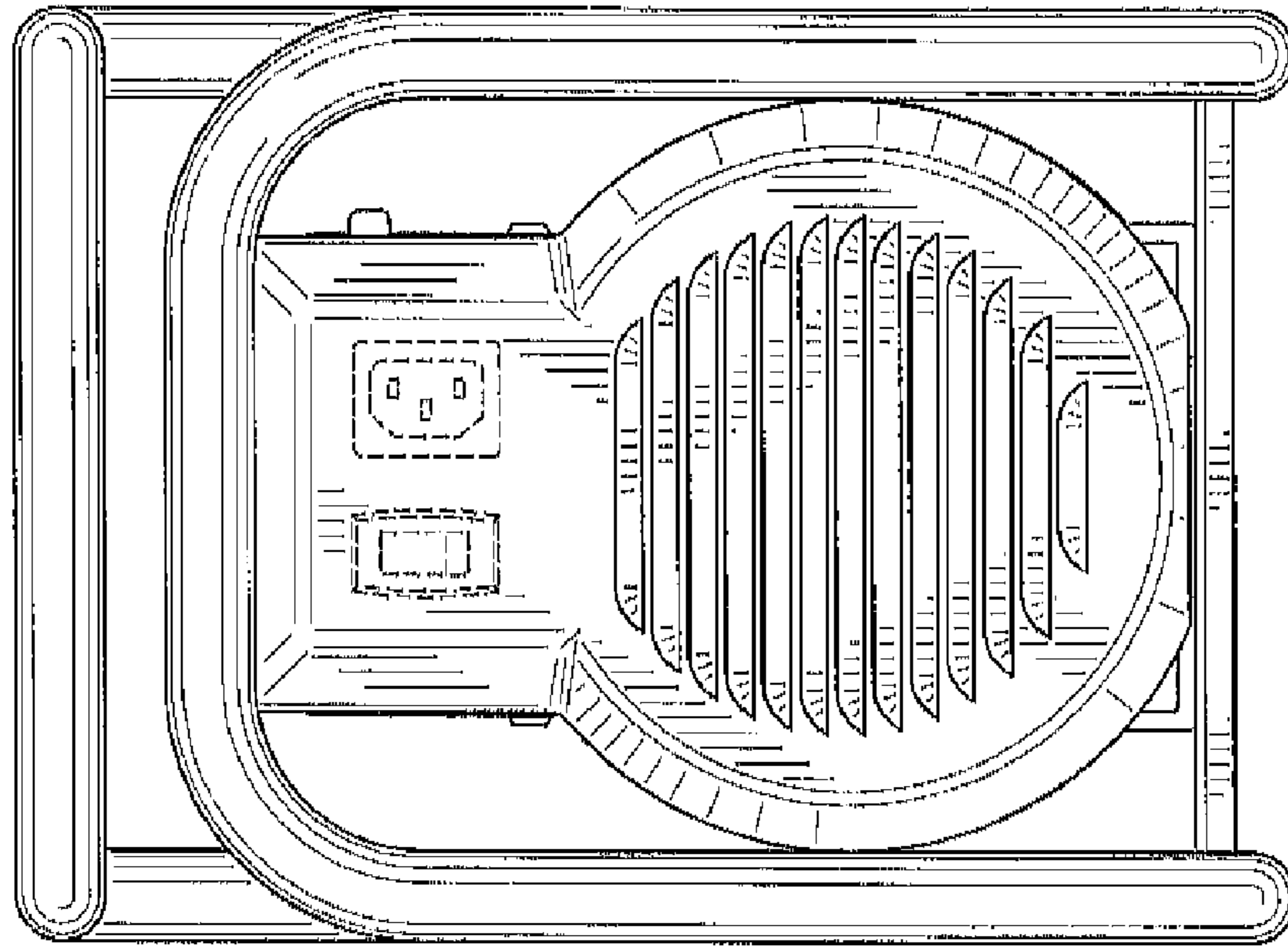

FIG. 5

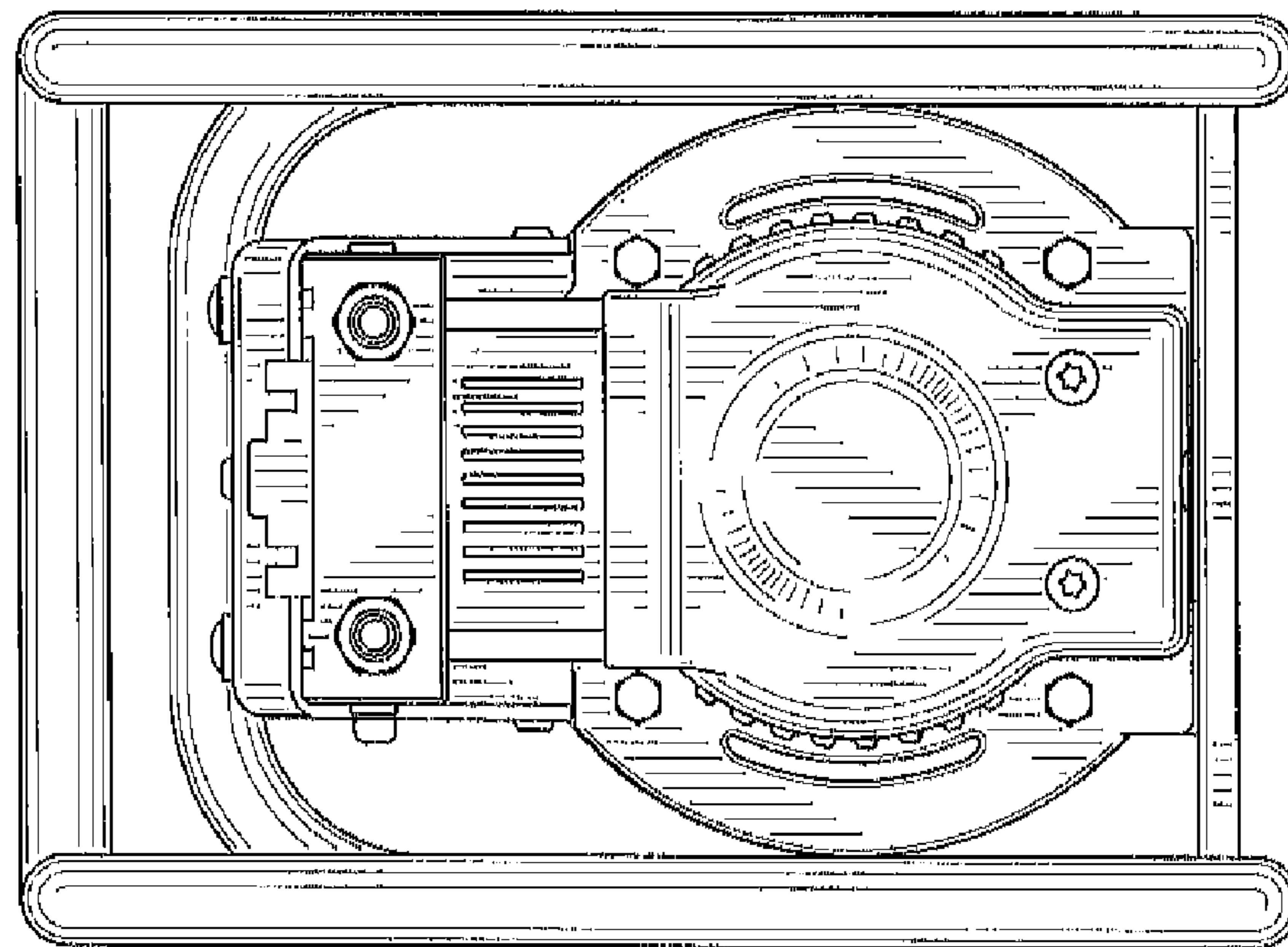

FIG. 4

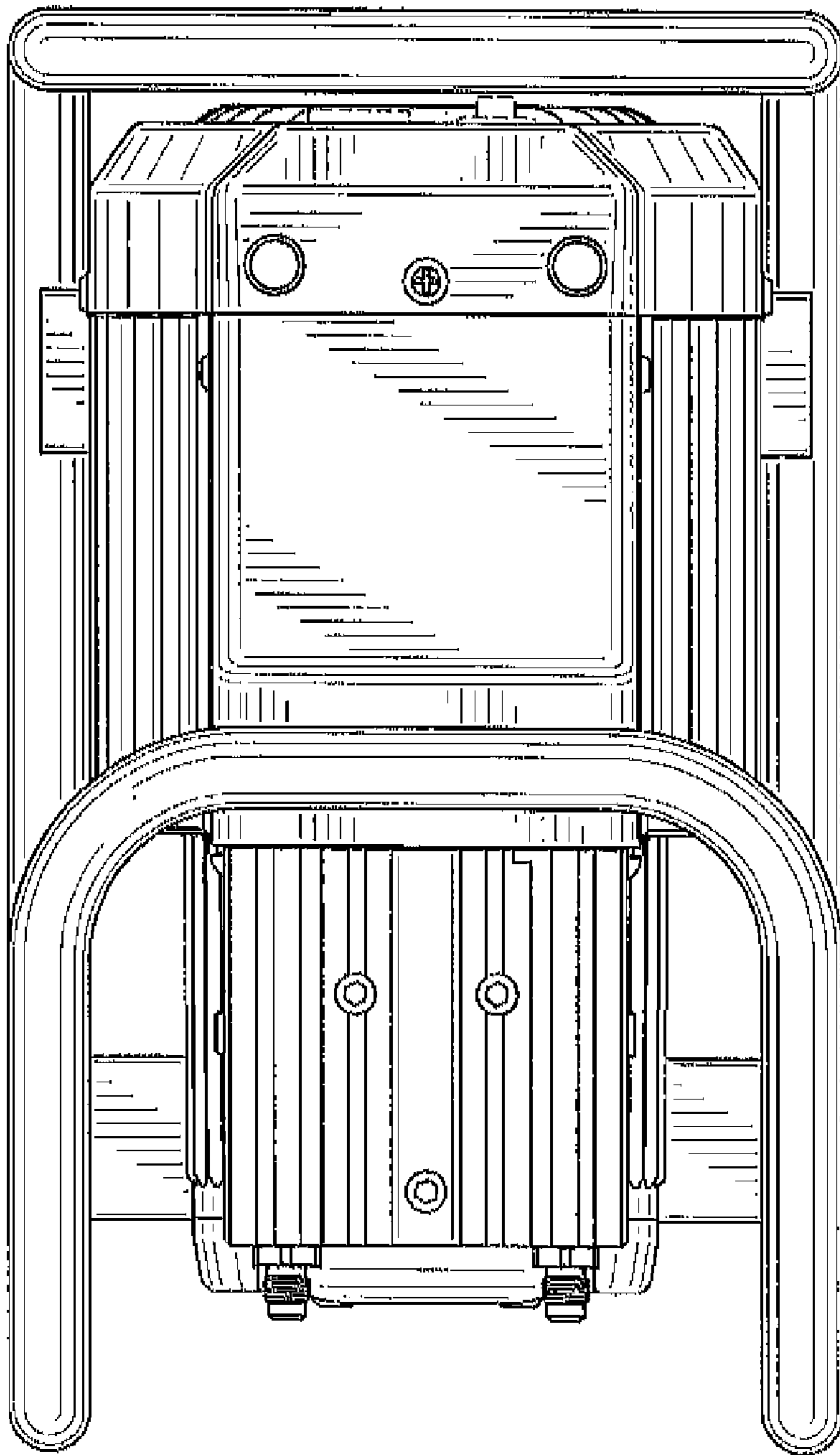

FIG. 6

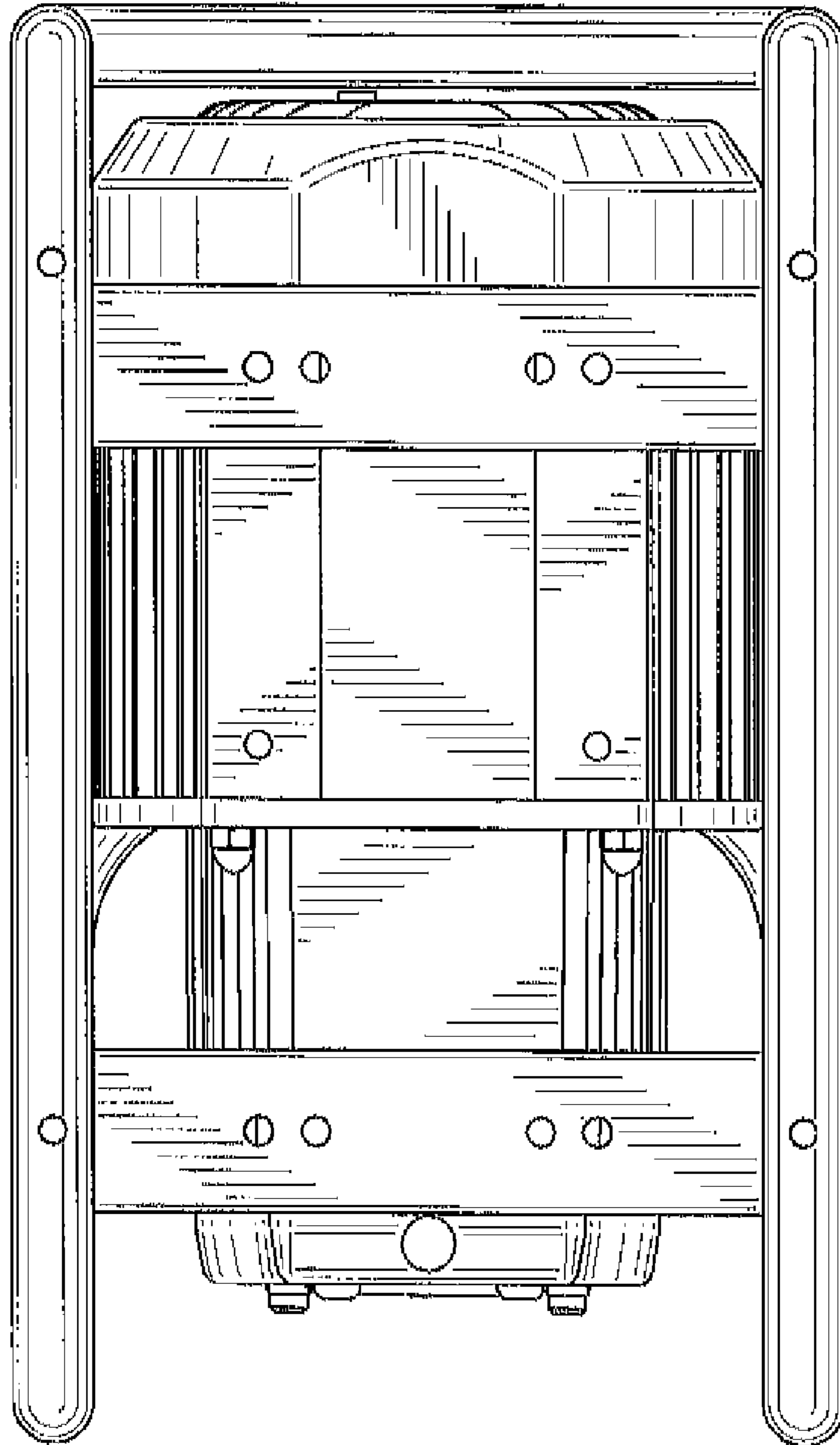

FIG. 7