



US00D665705S

(12) **United States Design Patent**
Lepine et al.

(10) **Patent No.:** **US D665,705 S**

(45) **Date of Patent:** **** Aug. 21, 2012**

(54) **ALL-TERRAIN VEHICLE BODY**

(75) Inventors: **Christian Lepine**, Bromont (CA); **Alain Massicotte**, Orford (CA); **Matt Tandrup**, Bromont (CA)

(73) Assignee: **Bombardier Recreational Products Inc.**, Valcourt, CA (US)

(**) Term: **14 Years**

(21) Appl. No.: **29/394,962**

(22) Filed: **Jun. 23, 2011**

(51) **LOC (9) Cl.** **12-11**

(52) **U.S. Cl.** **D12/107**

(58) **Field of Classification Search** D12/107,
D12/182, 184, 186, 126, 3, 86, 87, 110, 173,
D12/190, 181; 180/223, 229, 233, 311, 312,
180/315; 296/77.1, 78.1, 187.12, 187.09,
296/192, 193.01, 193.02, 193.05, 193.08,
296/193.09, 187.11; 280/288.2, 152.1-152.3,
280/847-852

See application file for complete search history.

(56) **References Cited**

U.S. PATENT DOCUMENTS

D343,818 S *	2/1994	DeBaal et al.	D12/173
D472,857 S *	4/2003	Weber et al.	D12/173
D506,961 S *	7/2005	Sugimoto	D12/186
D528,044 S *	9/2006	Ichikawa et al.	D12/107
D561,064 S *	2/2008	Crepeau	D12/107
D562,189 S *	2/2008	Miwa et al.	D12/107
D573,066 S *	7/2008	Ichikawa et al.	D12/126
D593,002 S *	5/2009	Sanschagrin et al.	D12/107

* cited by examiner

Primary Examiner — Susan M Lee

Assistant Examiner — Linda G. Brooks

(74) *Attorney, Agent, or Firm* — Osler, Hoskin & Harcourt LLP

(57) **CLAIM**

The ornamental design for an all-terrain vehicle body, as shown and described.

DESCRIPTION

FIG. 1 is a perspective view taken from a front, left side of an all-terrain vehicle body according to our design;

FIG. 2 is a perspective view taken from a rear, left side thereof;

FIG. 3 is a top plan view thereof;

FIG. 4 is a bottom plan view thereof;

FIG. 5 is a left side elevation view thereof;

FIG. 6 is a right side elevation view thereof;

FIG. 7 is a front elevation view thereof;

FIG. 8 is a rear elevation view thereof; and,

FIG. 9 is a perspective view taken from a rear, left side thereof shown on an all-terrain vehicle shown in dotted lines.

Throughout the Figures, where shown: (i) the broken lines showing additional structure of the all-terrain vehicle body and the all-terrain vehicle on which it is shown in FIG. 9 are for illustrative purposes only and form no part of the claimed design; and (ii) in FIGS. 1, 2, 3, 4, 5, 7, 8 and 9, the dotted/dashed lines immediately adjacent solid lines represent unclaimed boundaries of the claimed design and as such, the unshaded surfaces defined by those dotted/dashed lines form no part of the claimed design. Portions of the all-terrain vehicle body not shown in the Figures and not otherwise described in this Specification do not form part of the claimed design.

1 Claim, 8 Drawing Sheets

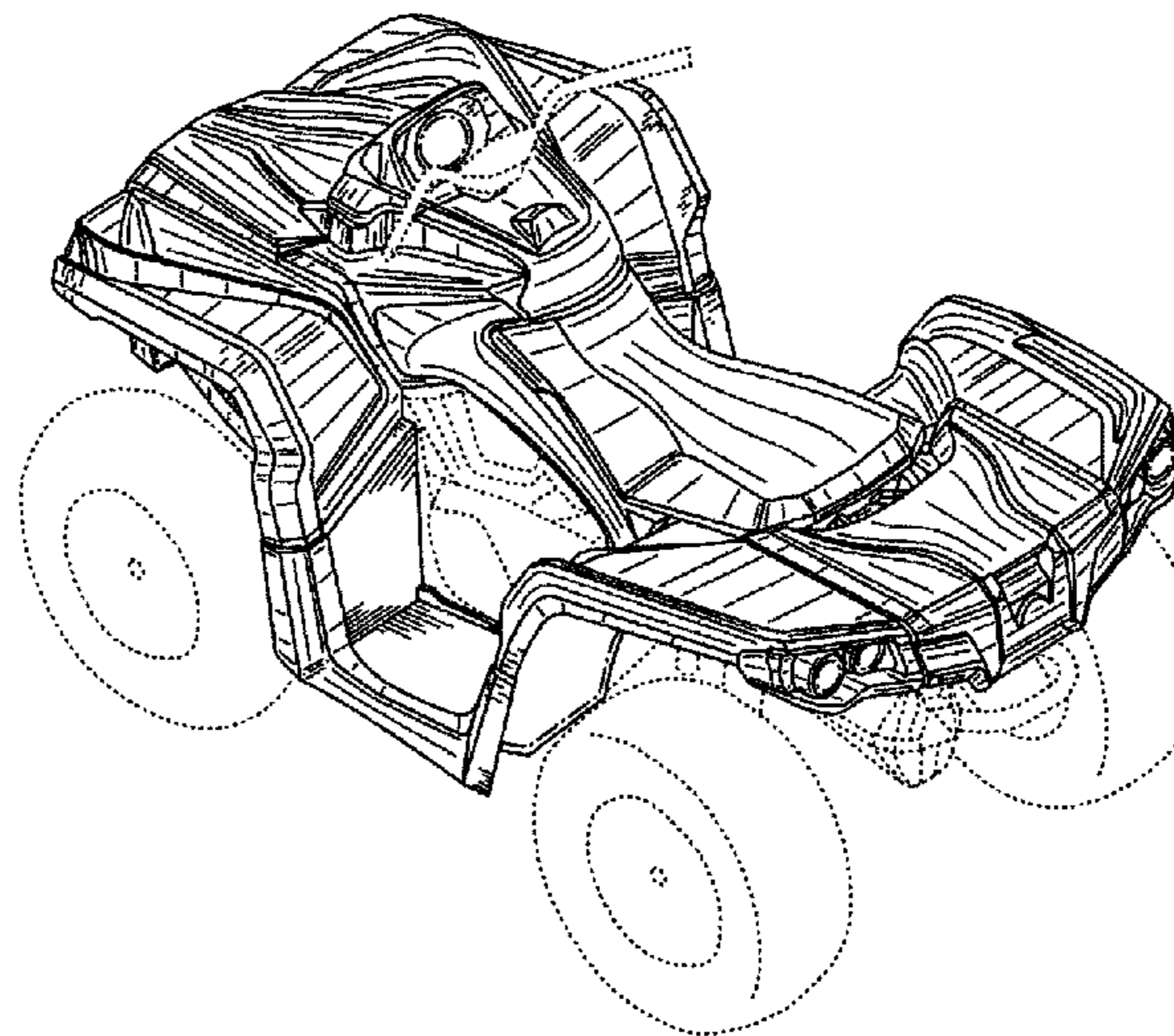
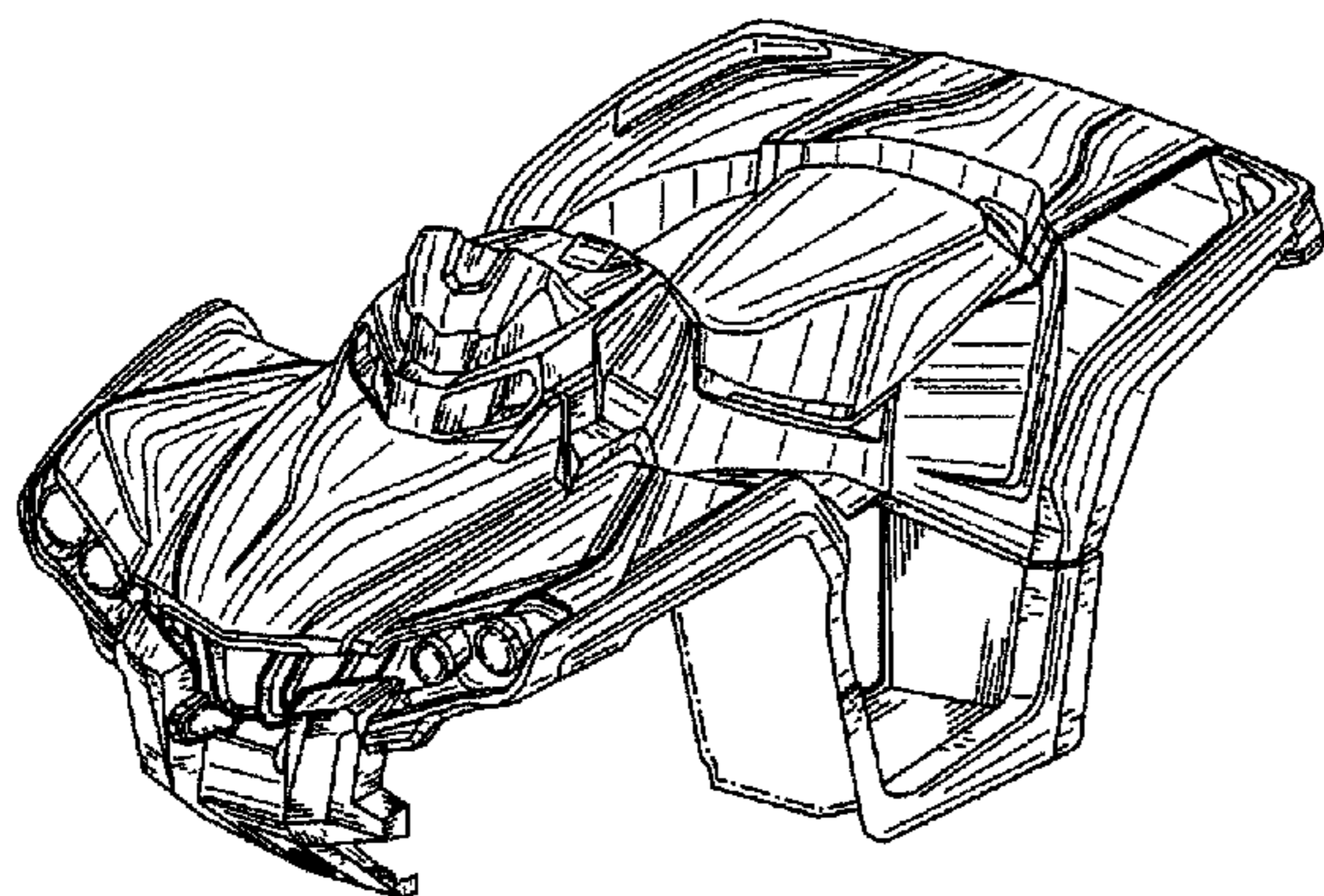

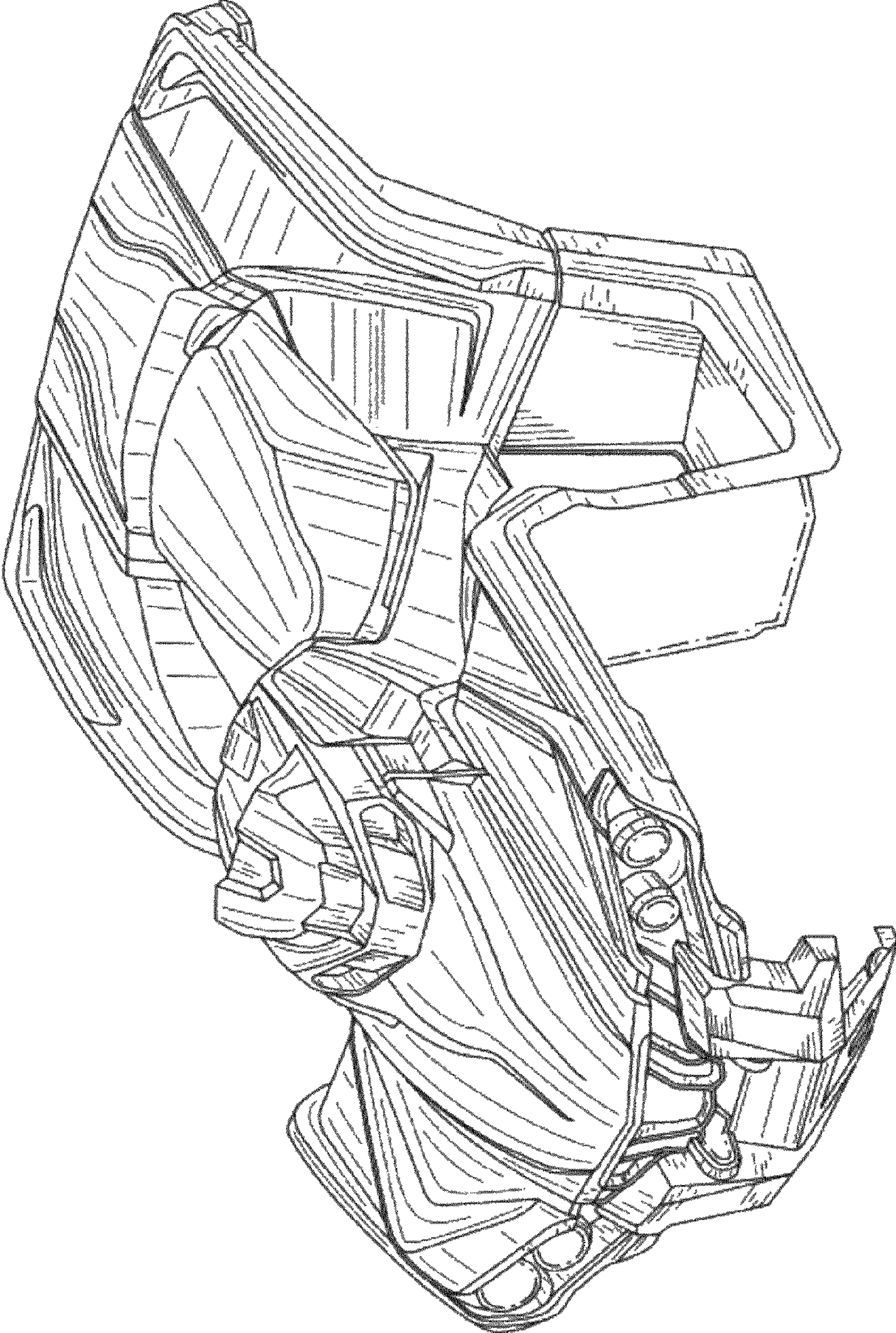

FIG. 1

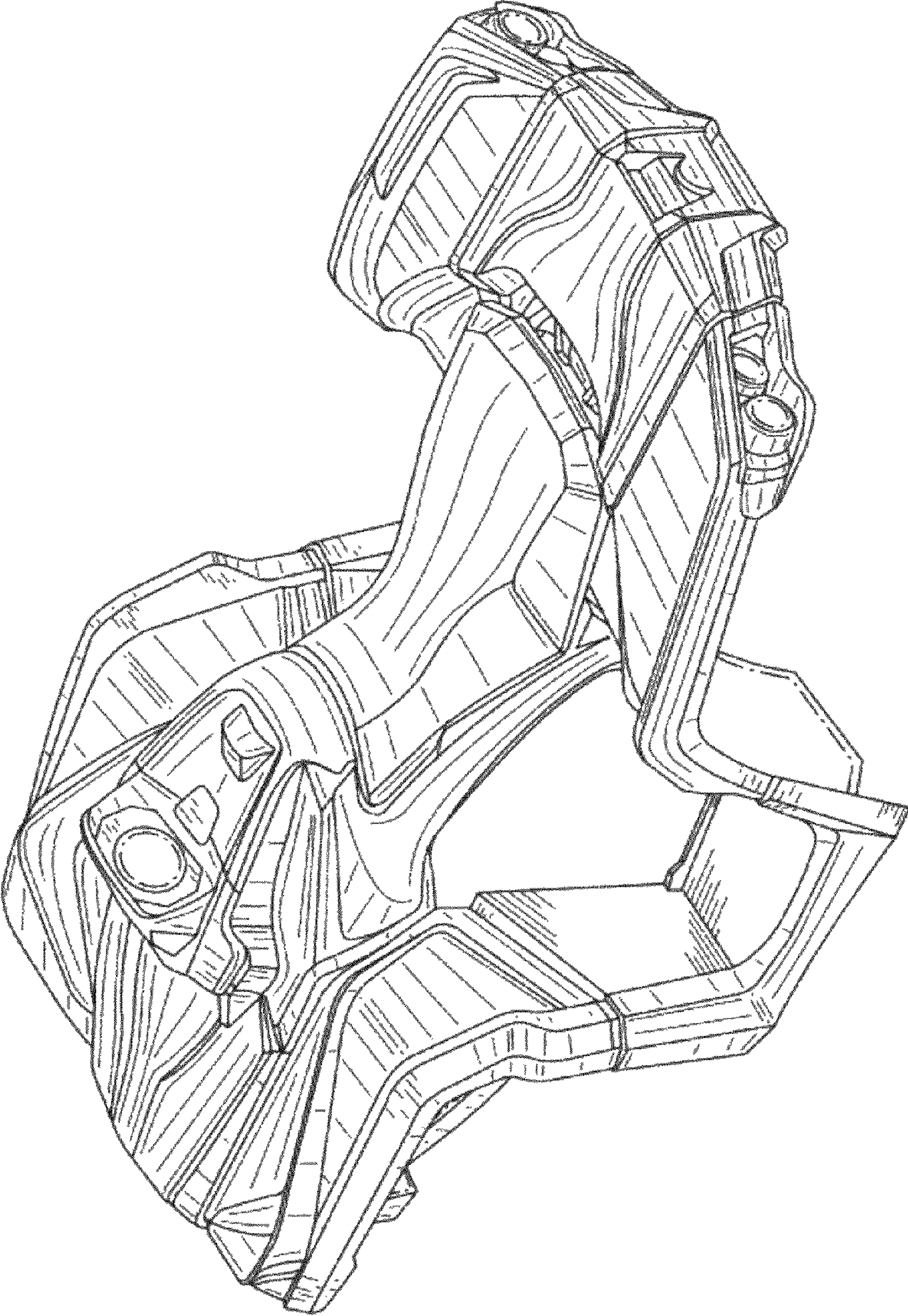

FIG. 2

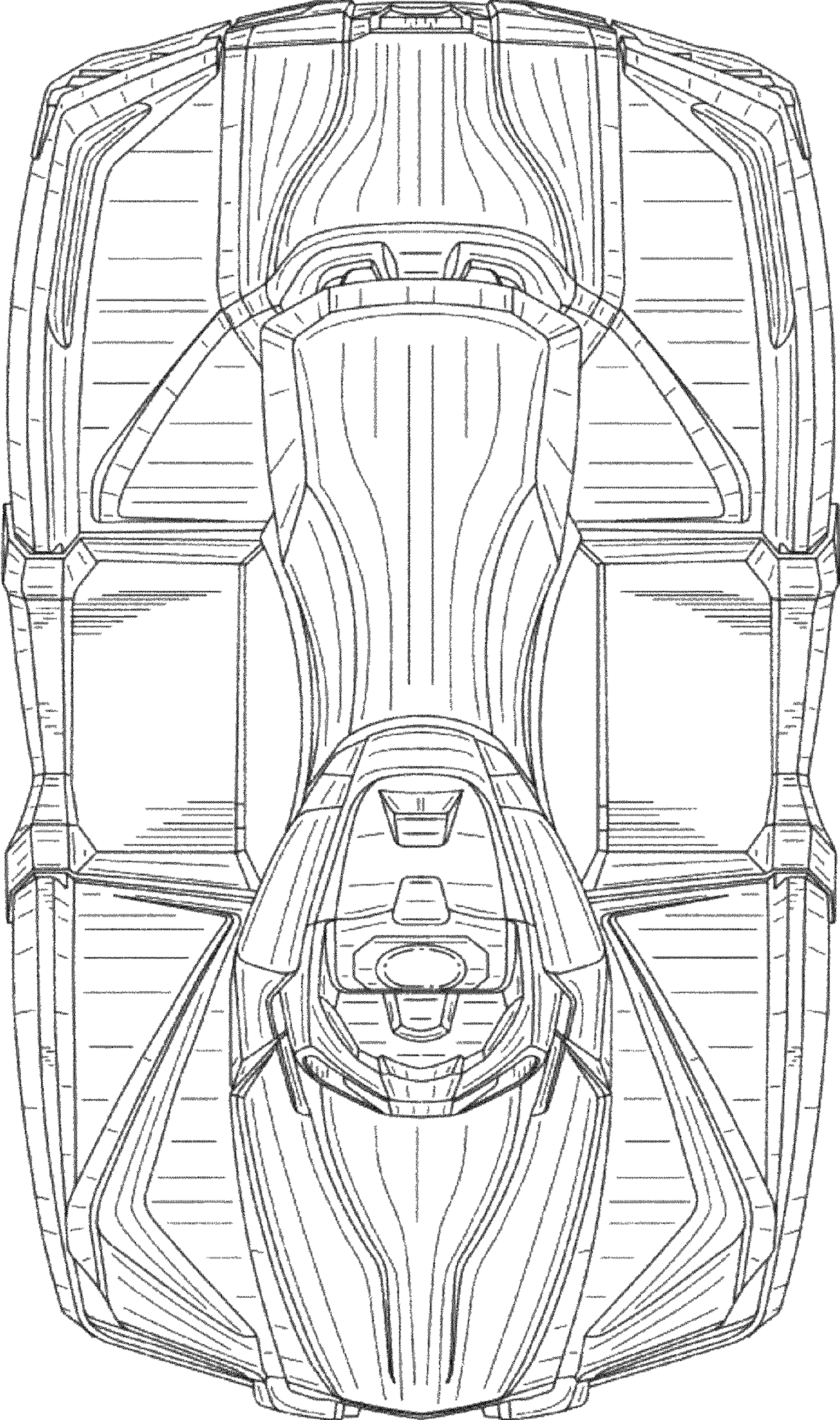

FIG. 3

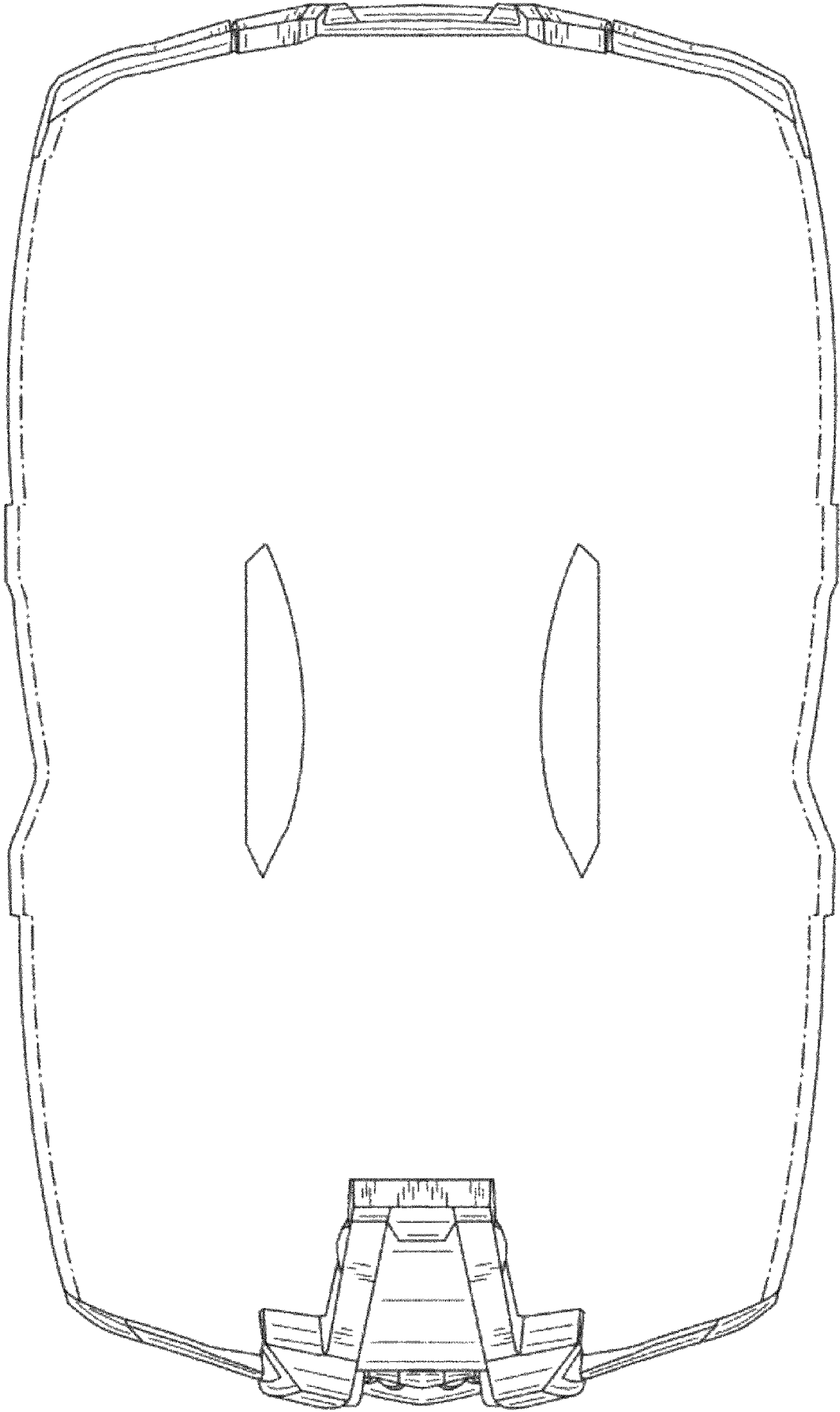

FIG. 4

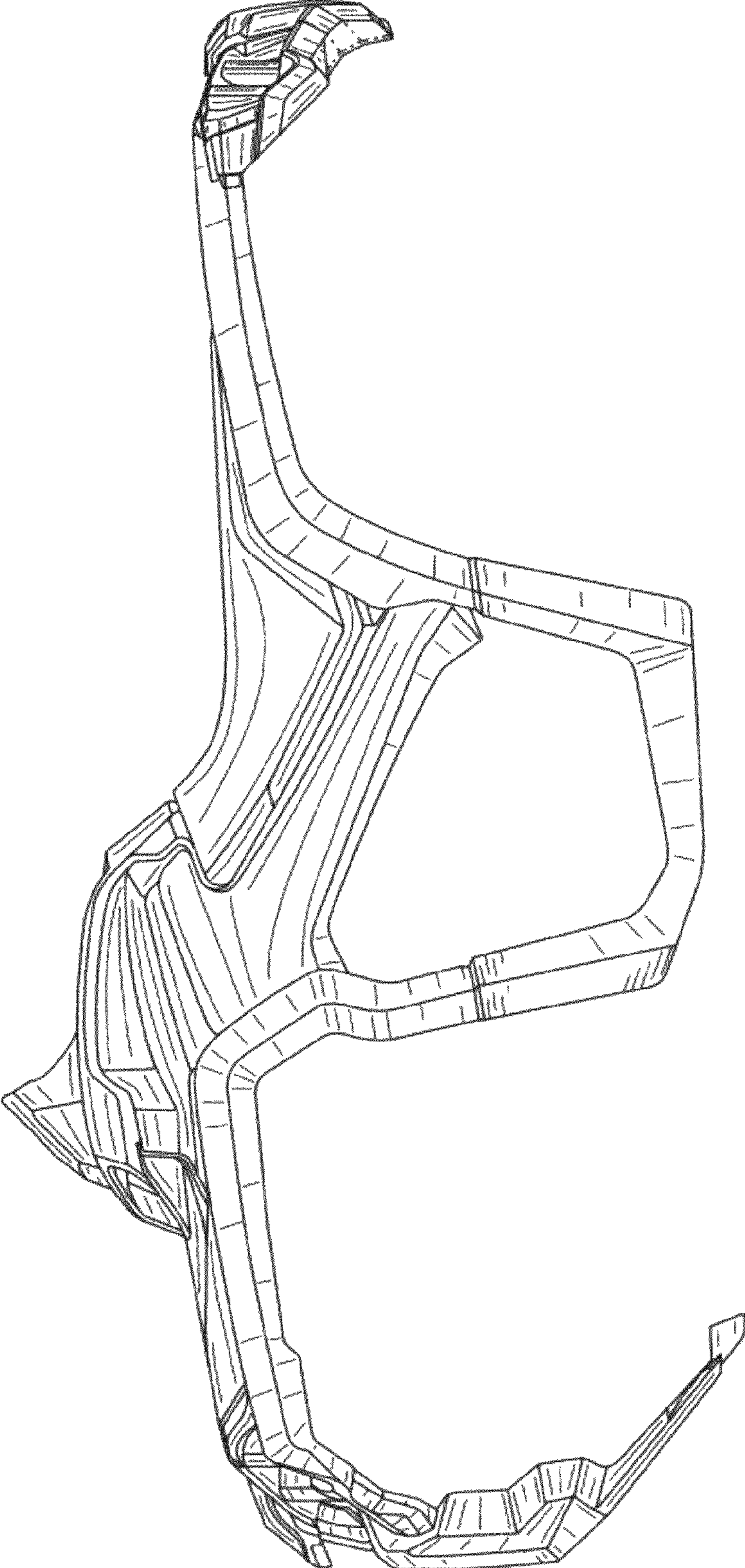

FIG. 5

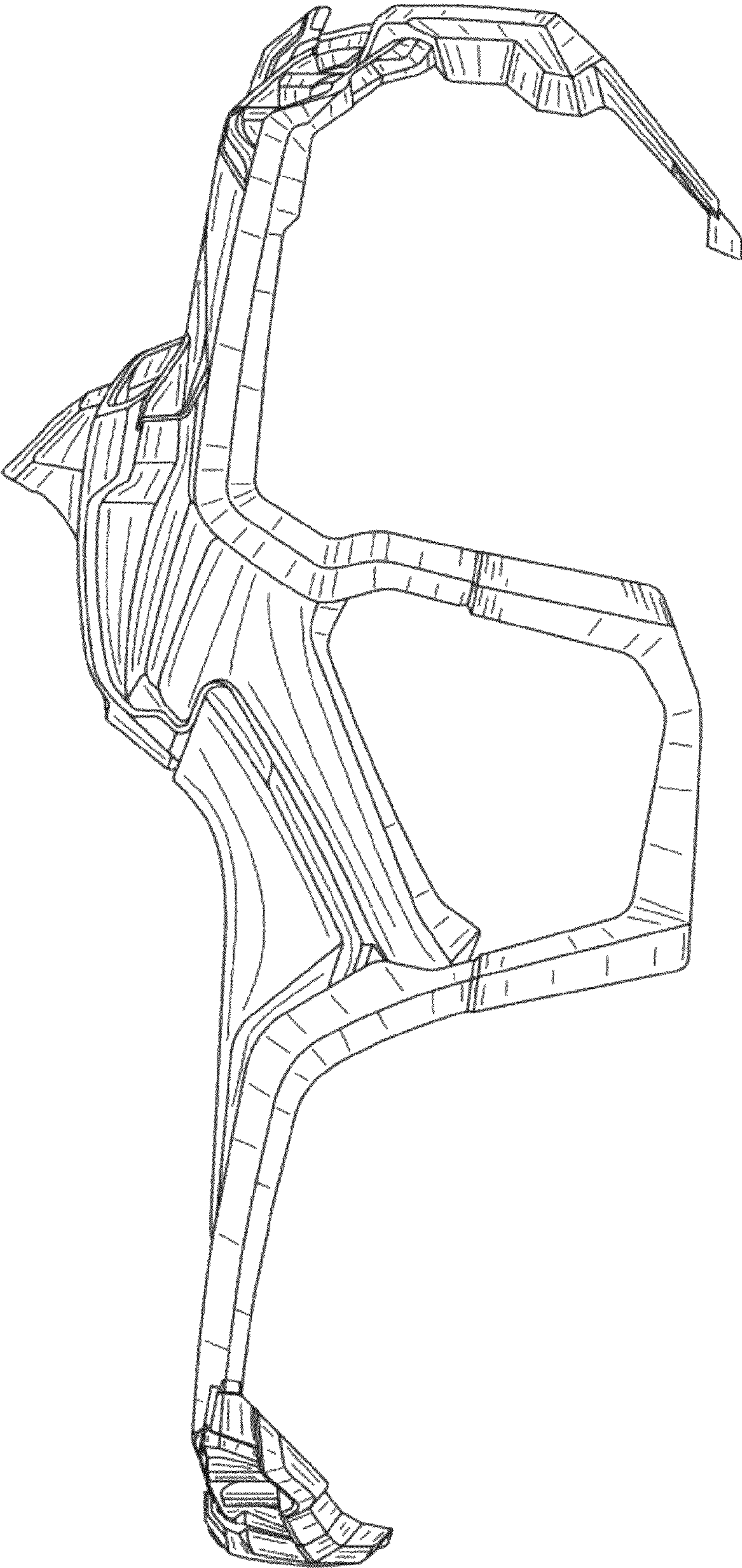

FIG. 6

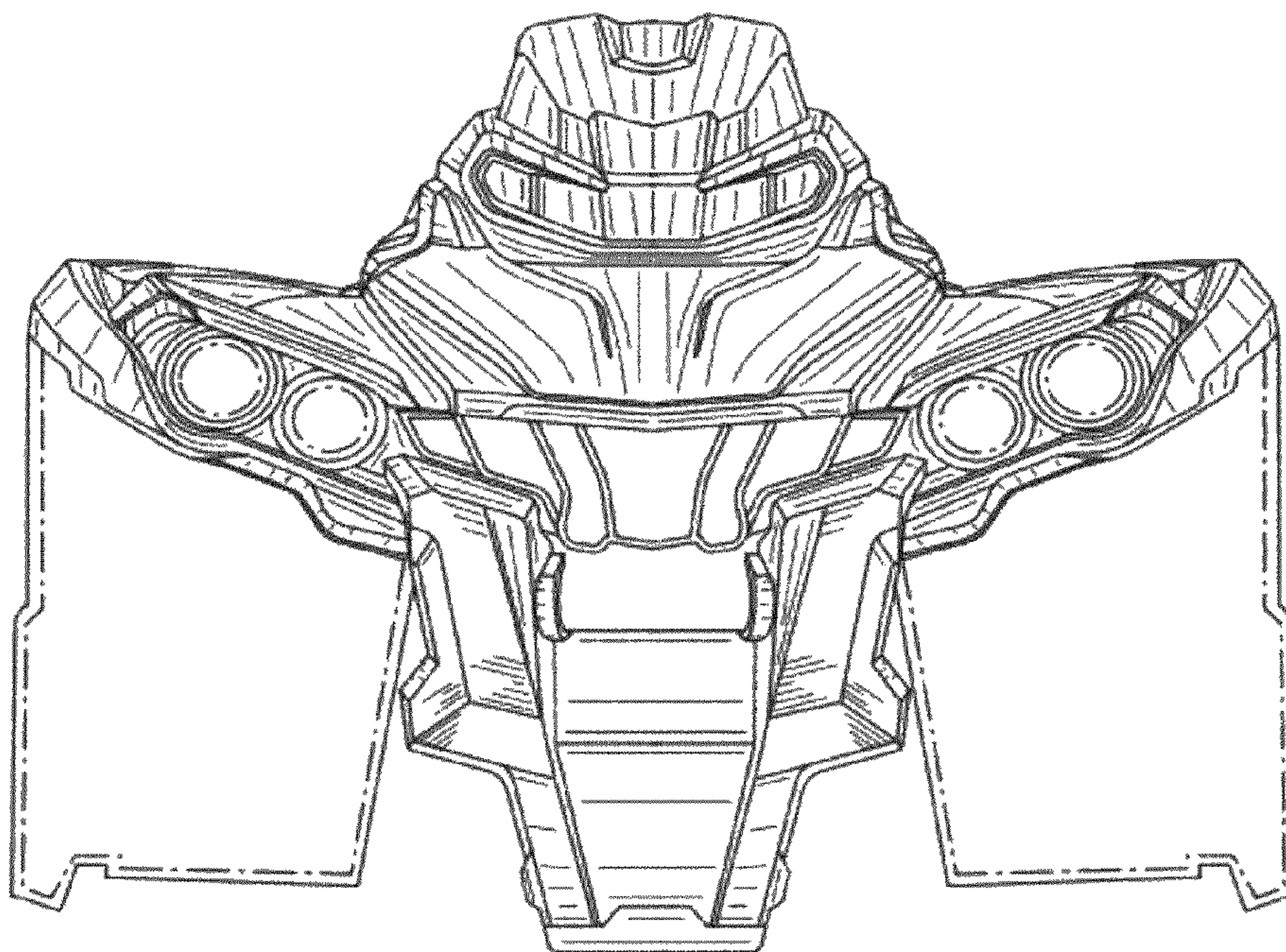

FIG. 7

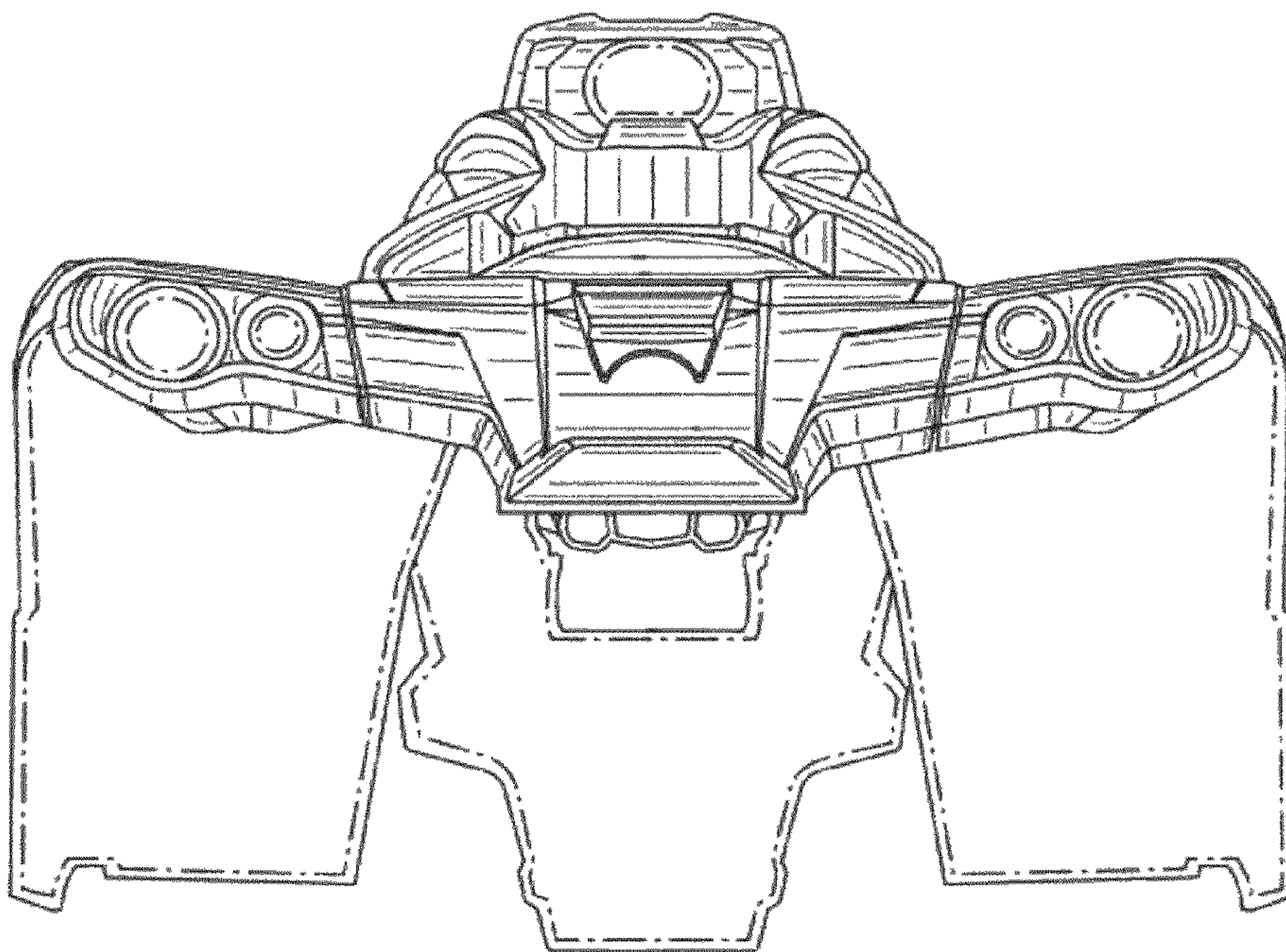

FIG. 8

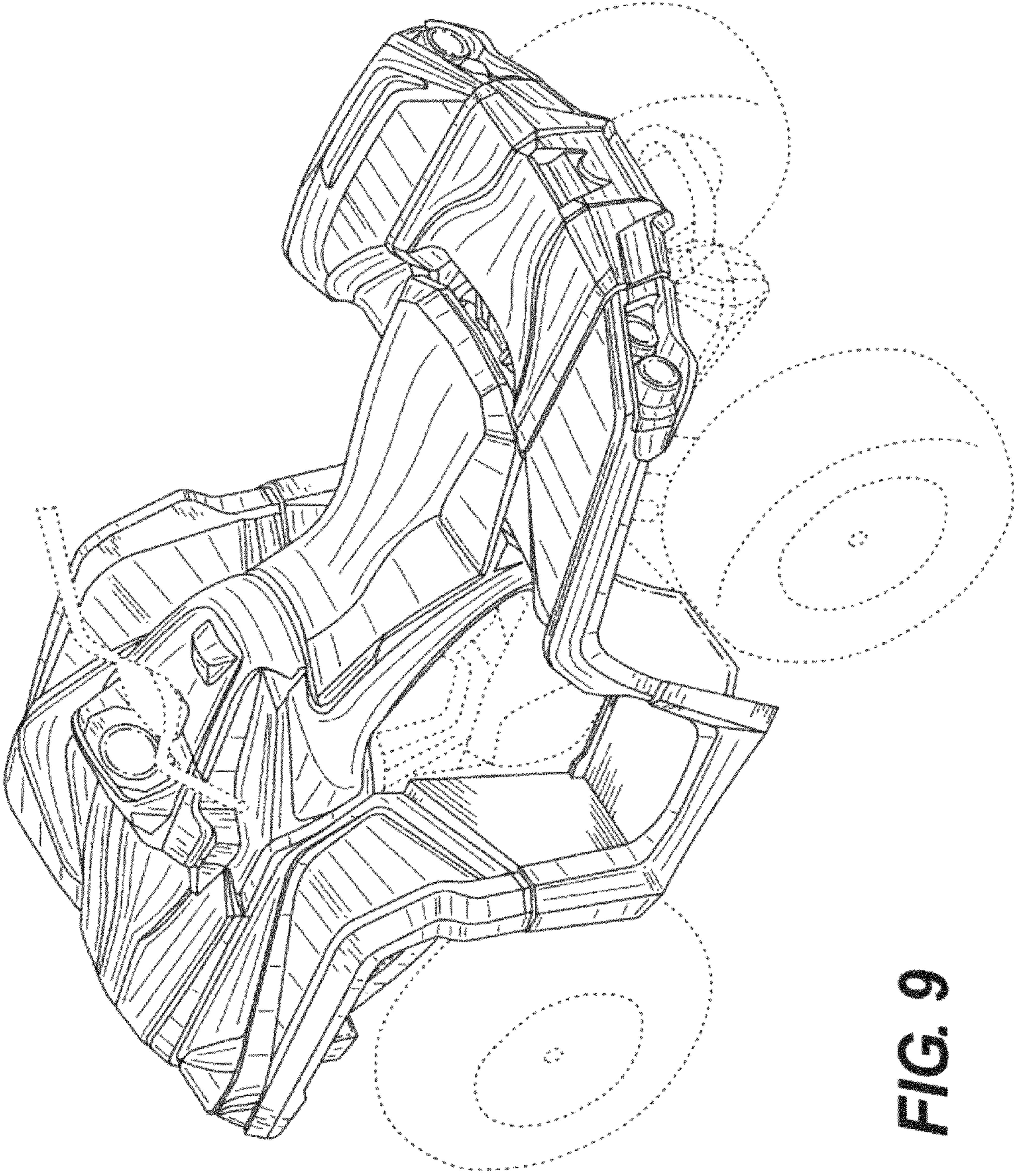

FIG. 9