



US00D665545S

(12) **United States Design Patent**
Alexander et al.

(10) **Patent No.:** **US D665,545 S**

(45) **Date of Patent:** **** Aug. 14, 2012**

(54) **PRESSURE WASHER**

(75) Inventors: **Gus Alexander**, Inverness, IL (US);
William N. Alexander, Inverness, IL
(US); **Christopher C. Alexander**,
Chicago, IL (US); **Ryan D. Sherwood**,
Chicago, IL (US)

(73) Assignee: **FNA IP Holdings, Inc.**, Elk Grove
Village, IL (US)

(**) Term: **14 Years**

(21) Appl. No.: **29/396,359**

(22) Filed: **Jun. 29, 2011**

(51) **LOC (9) Cl.** **15-05**

(52) **U.S. Cl.** **D32/15**

(58) **Field of Classification Search** D32/1,
D32/4, 15, 17, 18, 21; D23/223, 225, 226;
239/146, 308, 310, 332; 15/320-321, 327.1,
15/327.4-327.7, 344, 347, 353, 410, 412,
15/414, 415.1, 422; D34/12, 15, 18, 24
See application file for complete search history.

(56) **References Cited**

U.S. PATENT DOCUMENTS

D366,748	S	*	1/1996	Harrington	D34/24
D375,590	S	*	11/1996	Steinhart et al.	D32/15
D424,771	S	*	5/2000	Sivells et al.	D34/14
6,279,838	B1	*	8/2001	Sivells et al.	239/146
D451,257	S	*	11/2001	Moritsch	D34/24

D467,692	S	*	12/2002	Morgan et al.	D32/15
D499,848	S	*	12/2004	Leasure	D32/15
6,935,642	B1	*	8/2005	Craig et al.	280/47.24
D520,706	S	*	5/2006	Brekke	D34/15
D556,414	S	*	11/2007	Gong et al.	D34/15
D590,110	S	*	4/2009	Hawkins	D32/25
D604,024	S	*	11/2009	Chitty et al.	D34/24
D632,448	S	*	2/2011	Simko et al.	D34/12
D633,682	S	*	3/2011	Schmid	D34/26
D634,083	S	*	3/2011	Fay	D32/15
D639,001	S	*	5/2011	Alexander et al.	D32/15
D648,082	S	*	11/2011	Alexander et al.	D32/15
2006/0102745	A1	*	5/2006	Dexter	239/146

* cited by examiner

Primary Examiner — T. Chase Nelson

Assistant Examiner — Kathleen M Sims

(74) *Attorney, Agent, or Firm* — Holland & Knight, LLP

(57) **CLAIM**

The ornamental design for a pressure washer, as shown and described.

DESCRIPTION

FIG. 1 is a perspective view of a pressure washer;

FIG. 2 is a front elevation view thereof;

FIG. 3 is a rear elevation view thereof;

FIG. 4 is a left side elevation view thereof;

FIG. 5 is a right side elevation view thereof;

FIG. 6 is a top plan view thereof; and,

FIG. 7 is a bottom plan view thereof.

The broken lines in FIGS. 1-7 are for illustrative purposes only and form no part of the claimed design.

1 Claim, 6 Drawing Sheets

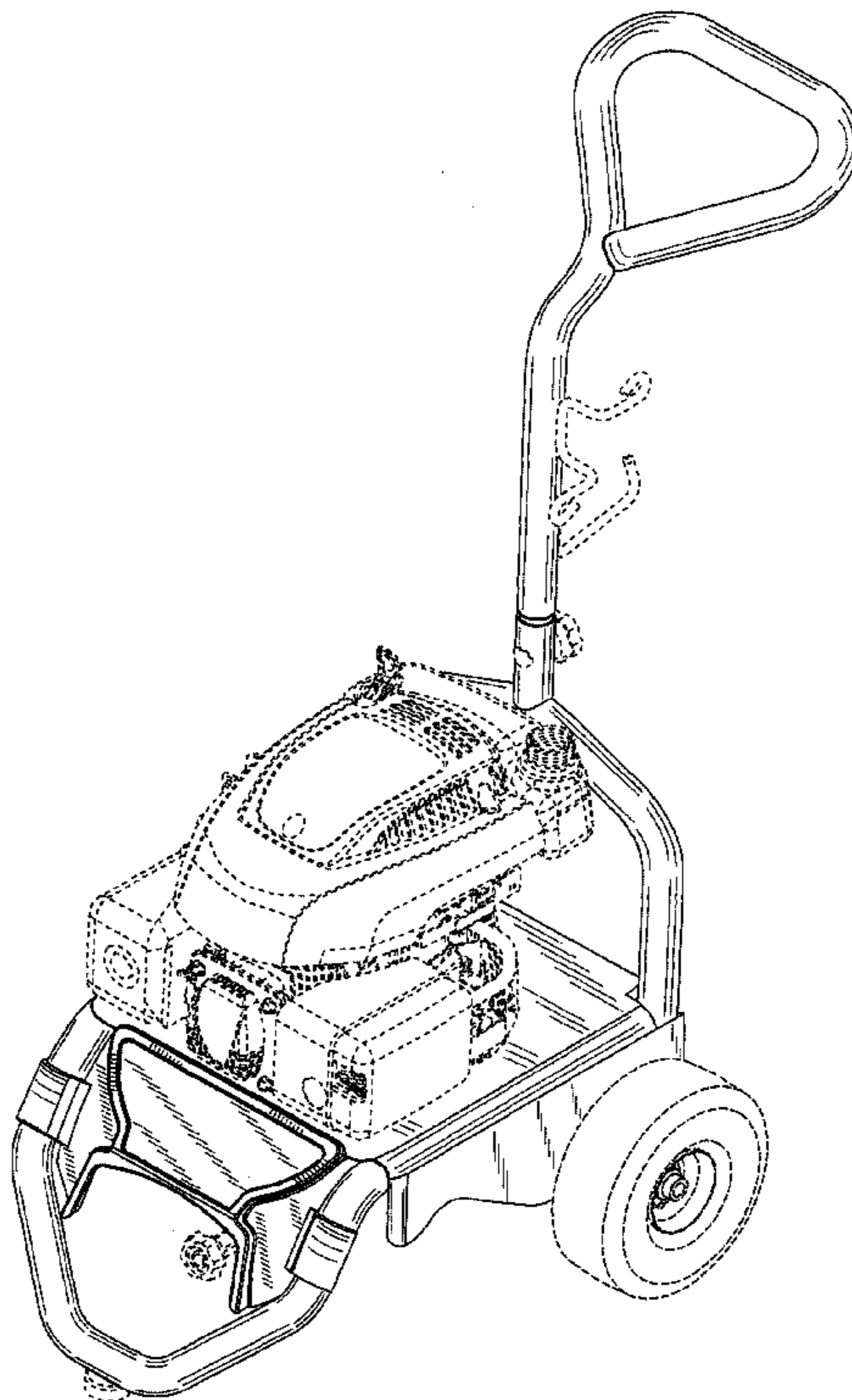

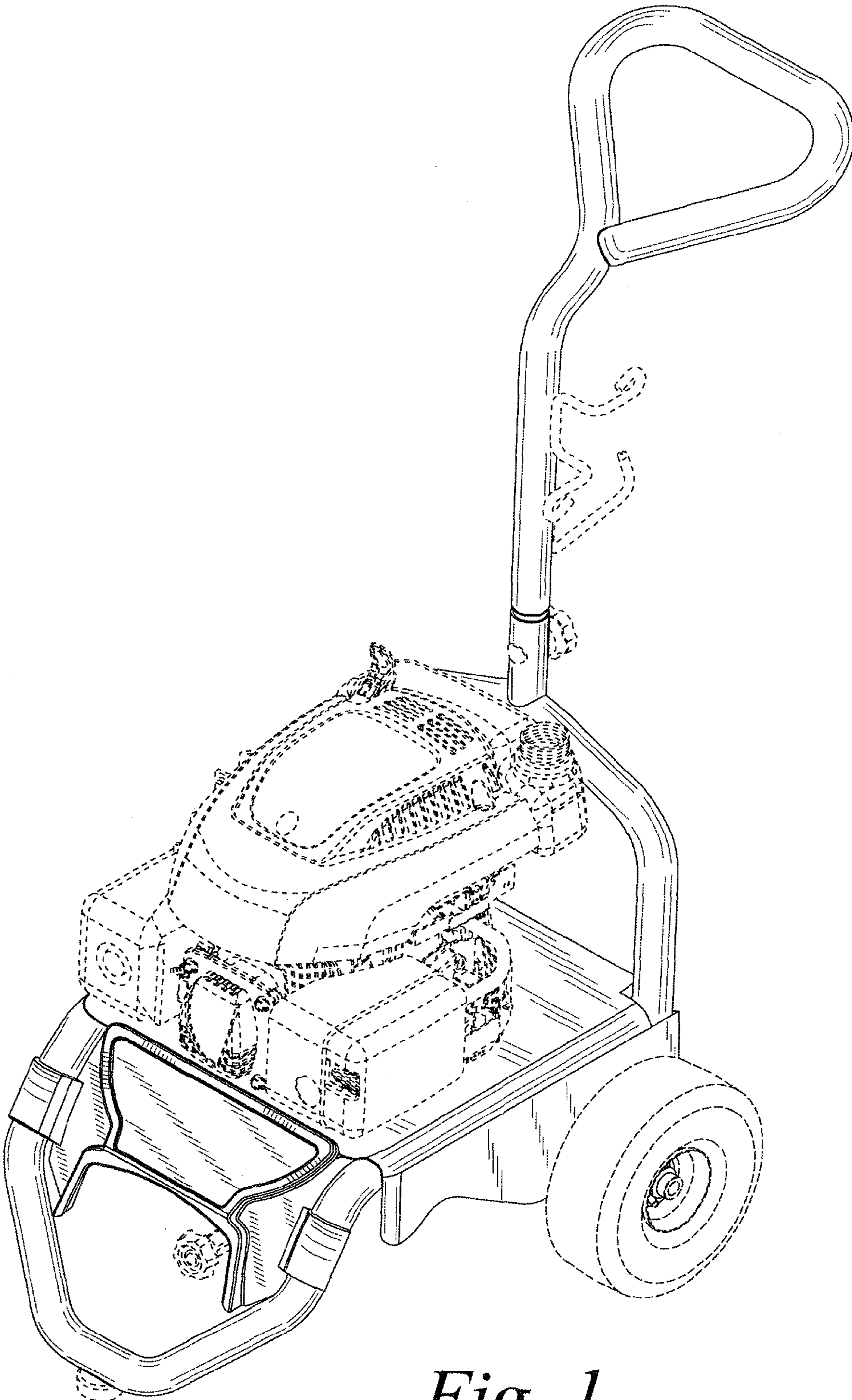

Fig. 1

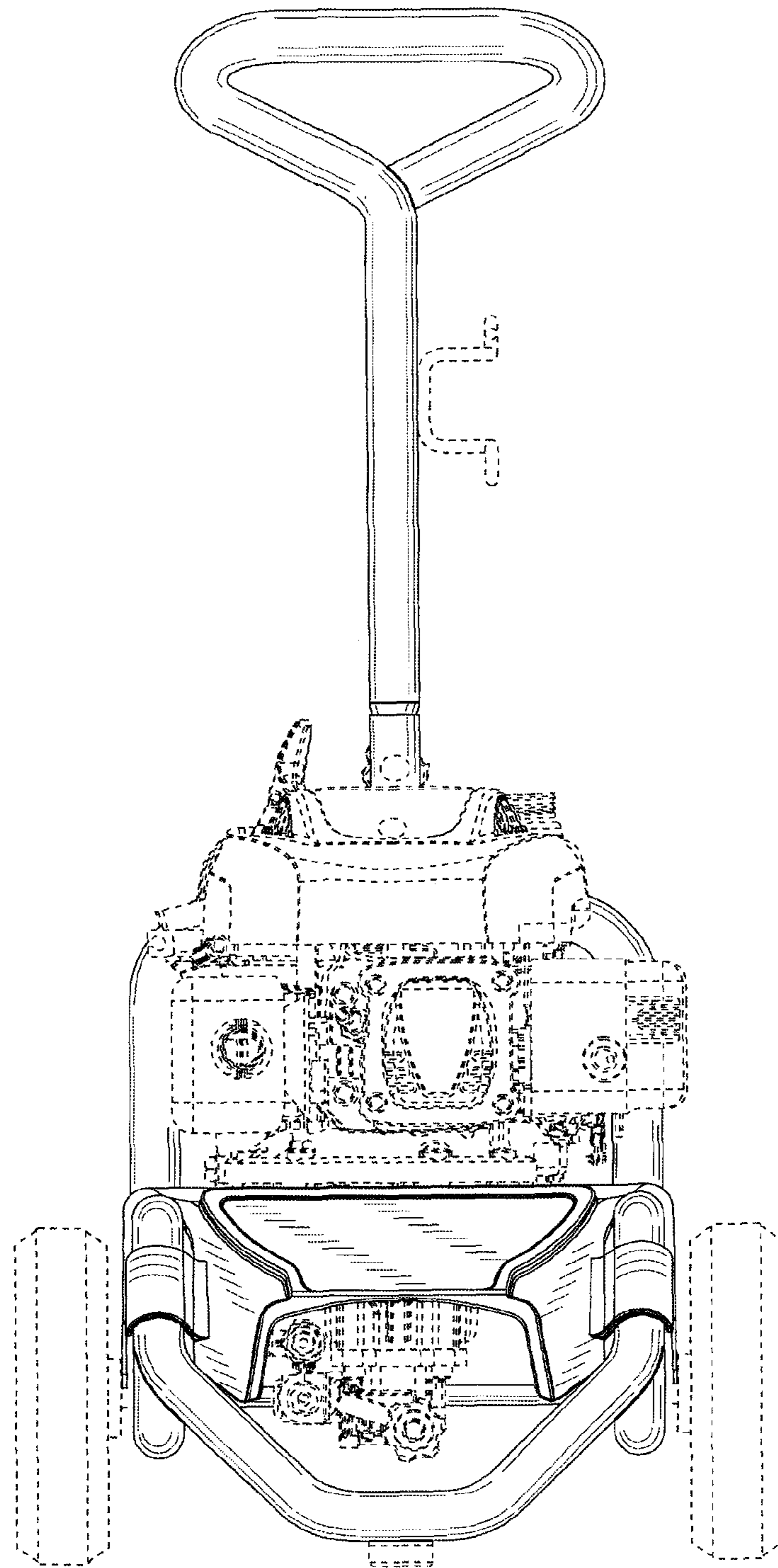

Fig. 2

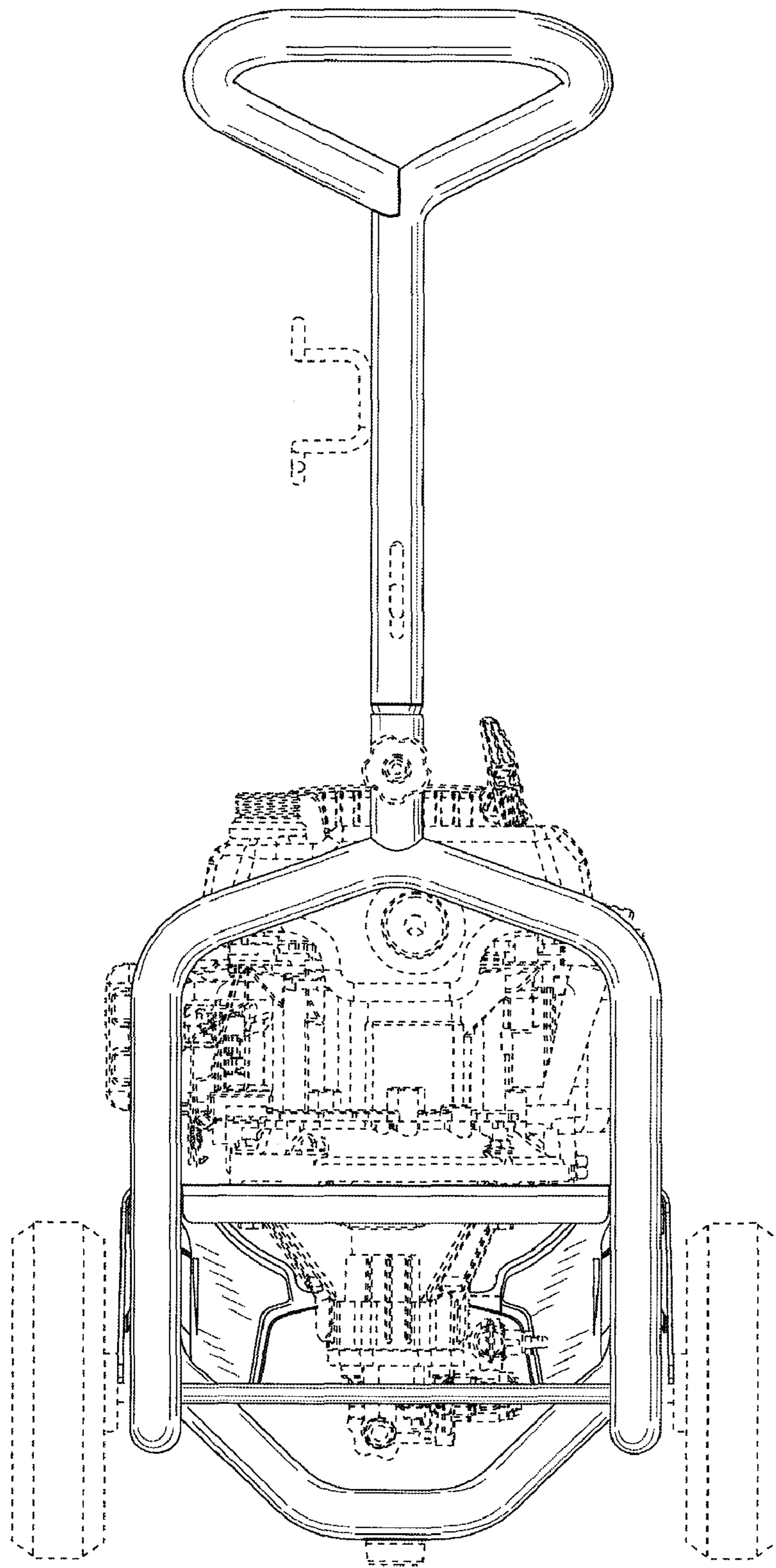

Fig. 3

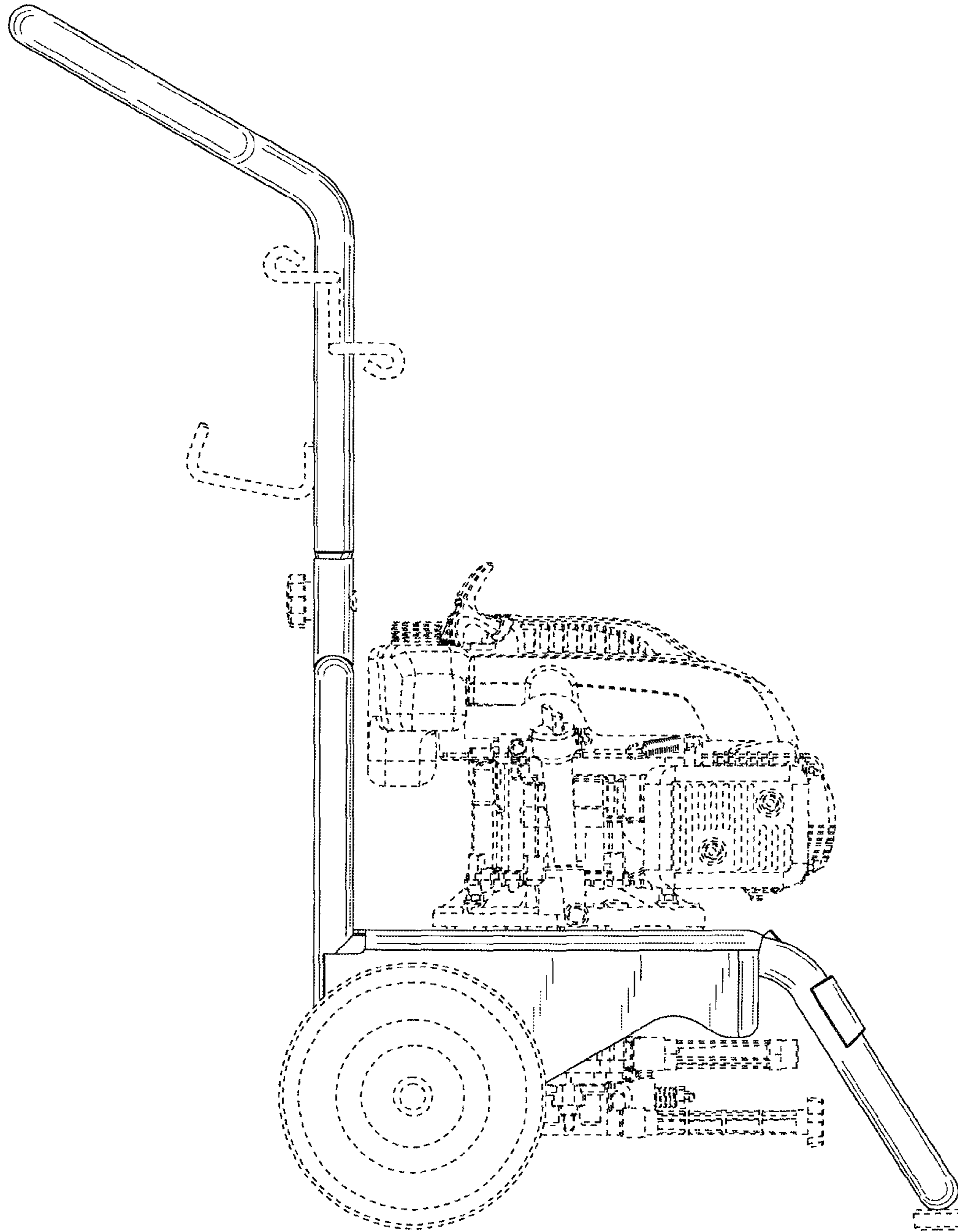

Fig. 4

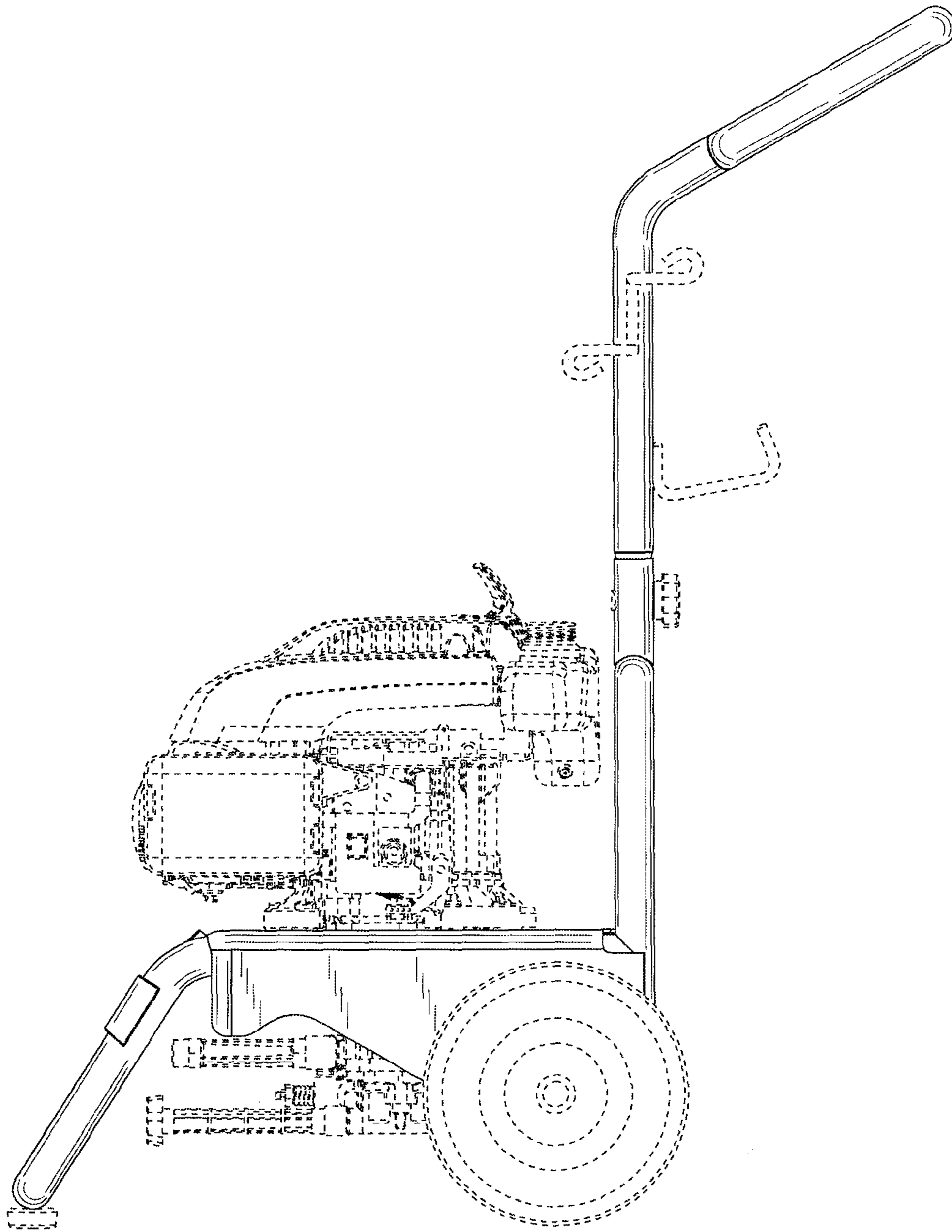

Fig. 5

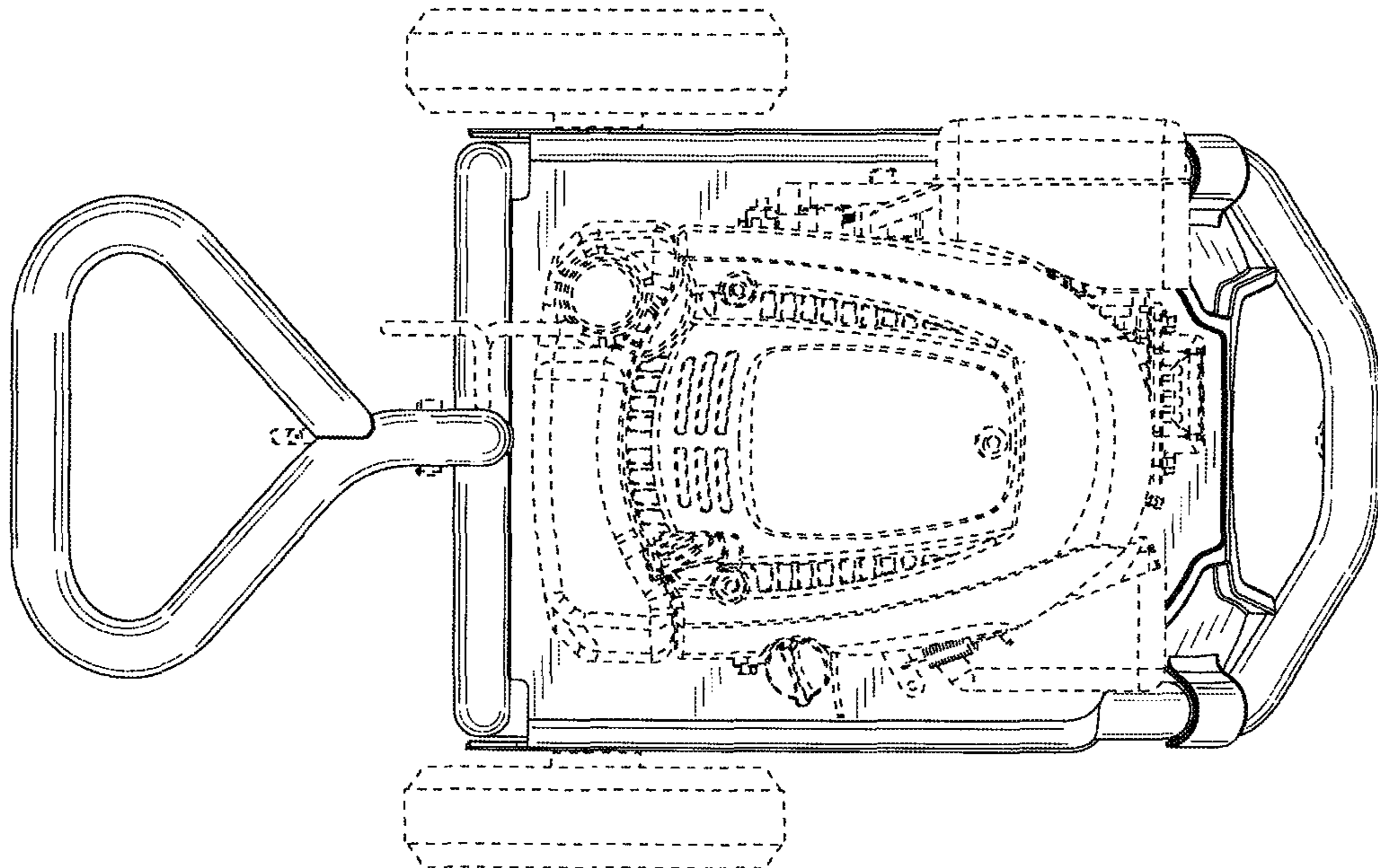

Fig. 6

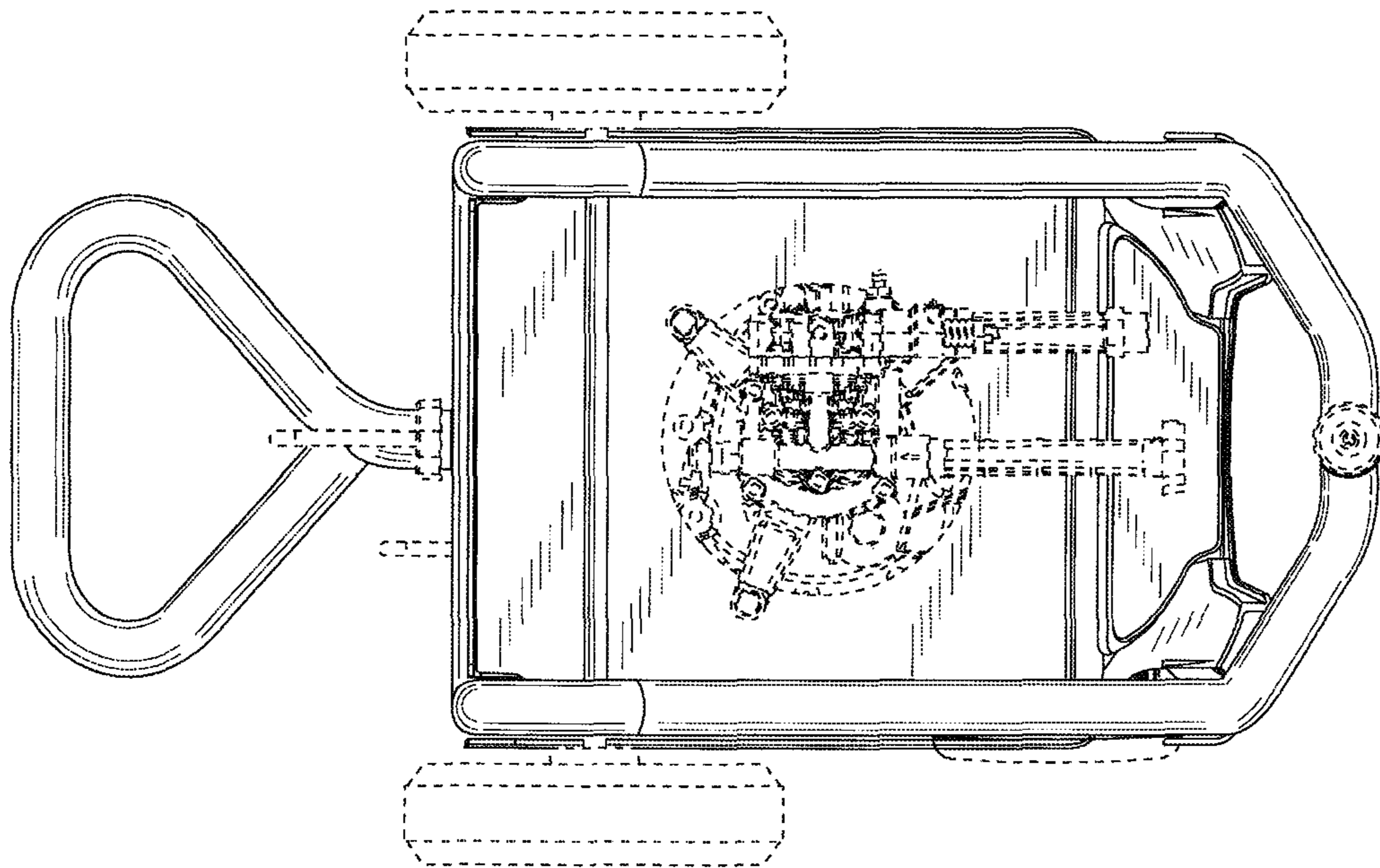

Fig. 7