



US00D665270S

(12) **United States Design Patent**
Leclezio

(10) **Patent No.:** **US D665,270 S**

(45) **Date of Patent:** **** Aug. 14, 2012**

(54) **PACKAGING**

(75) Inventor: **Fred Leclezio**, Montreal (CA)

(73) Assignee: **Imperial Tobacco Canada Limited**,
Montreal (CA)

(**) Term: **14 Years**

(21) Appl. No.: **29/367,613**

(22) Filed: **Aug. 10, 2010**

Related U.S. Application Data

(62) Division of application No. 29/329,934, filed on Dec. 23, 2008, now Pat. No. Des. 624,437.

(30) **Foreign Application Priority Data**

Jul. 1, 2008 (WO) DM/070 371

(51) **LOC (9) Cl.** **09-05**

(52) **U.S. Cl.** **D9/707**

(58) **Field of Classification Search** D9/428,
D9/703, 707, 721; 131/152; 206/205; 383/107,
383/108, 207; 426/115

See application file for complete search history.

(56) **References Cited**

U.S. PATENT DOCUMENTS

D30,228 S	2/1899	Wolf	
3,175,753 A *	3/1965	Civitello	383/107
3,291,374 A	12/1966	Lepisto et al.	
3,415,440 A *	12/1968	Watters	383/108
D280,058 S	8/1985	Carlson	
4,739,879 A *	4/1988	Nakamura	206/205

5,445,454 A *	8/1995	Barkhorn	383/207
5,489,658 A *	2/1996	Huang	426/115
D369,095 S *	4/1996	Shelburne	D9/646
D414,407 S	9/1999	Simburger et al.	
6,708,823 B2	3/2004	Cottingham et al.	
D489,606 S	5/2004	Lofman	
D496,263 S	9/2004	Chen	
D548,070 S	8/2007	Swain	
D592,494 S	5/2009	Wichowski	
D609,855 S	2/2010	Patel et al.	
D624,437 S *	9/2010	Leclezio	D9/721
7,950,399 B2 *	5/2011	Winterson et al.	131/352
D640,131 S *	6/2011	Gibson et al.	D9/428
D640,566 S *	6/2011	Norlin et al.	D9/707
7,980,251 B2 *	7/2011	Winterson et al.	131/352
D643,745 S *	8/2011	Hartley	D9/707

* cited by examiner

Primary Examiner — Thomas Johannes

(74) *Attorney, Agent, or Firm* — Chadbourne & Parke LLP

(57) **CLAIM**

The ornamental design for packaging, as shown and described.

DESCRIPTION

FIG. 1 is an above front right perspective view of a first embodiment of packaging showing the new design; FIG. 2 is a top view thereof; FIG. 3 is an above front right perspective view of a second embodiment of packaging showing the new design; and, FIG. 4 is a top view thereof.

The broken line portion of the figure drawings is included to show unclaimed subject matter only and forms no part of the claimed design.

1 Claim, 2 Drawing Sheets

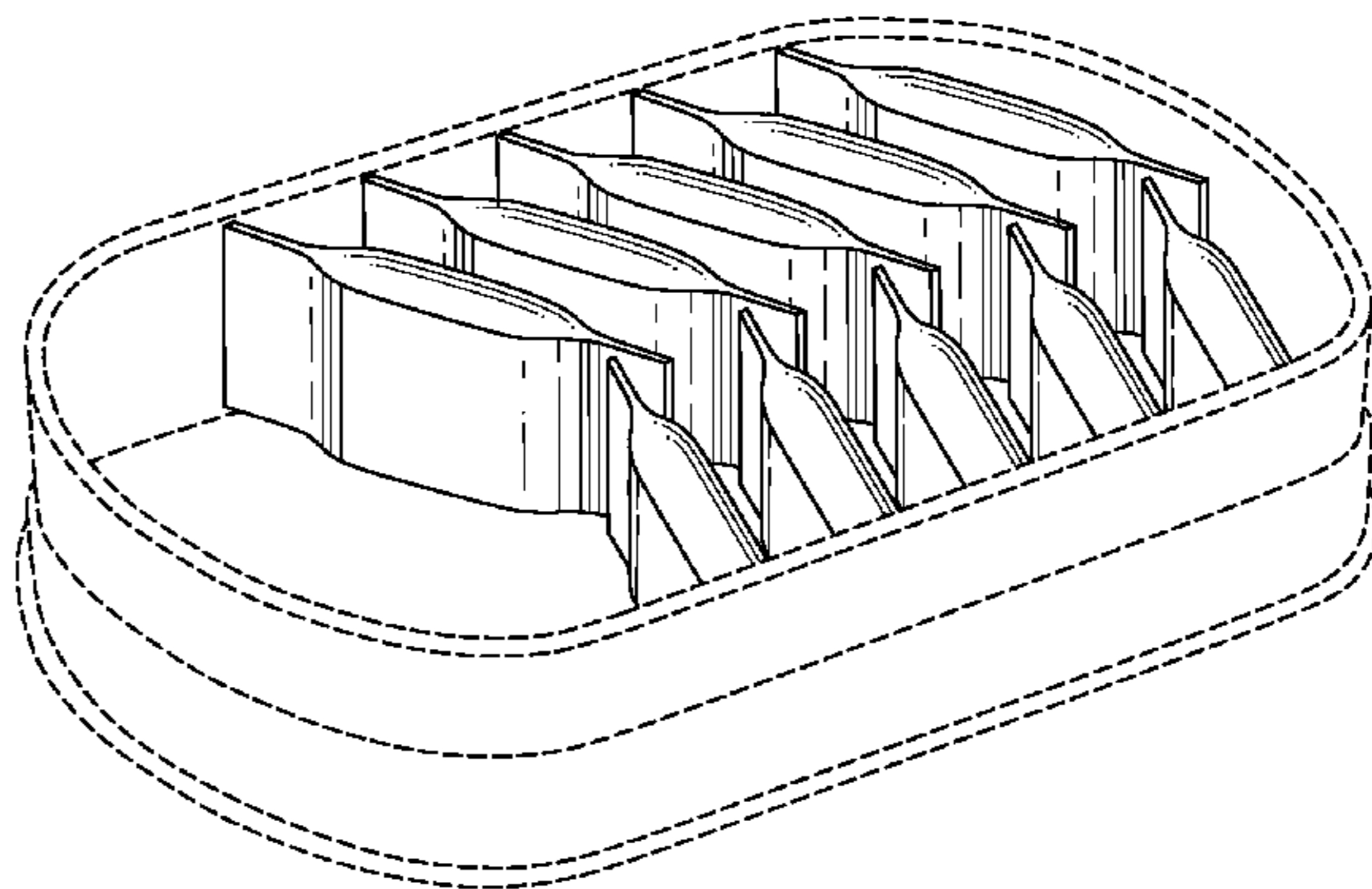
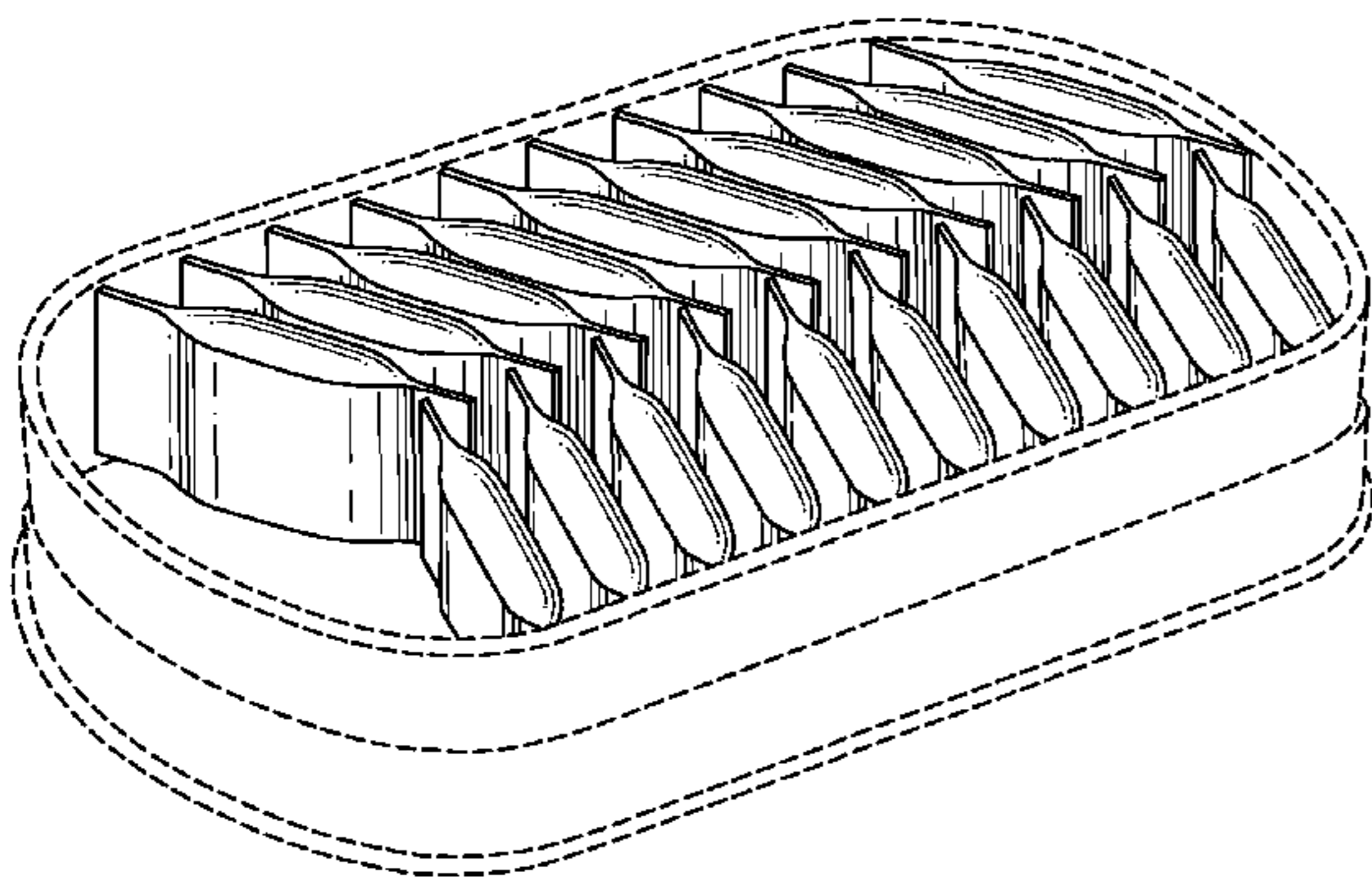

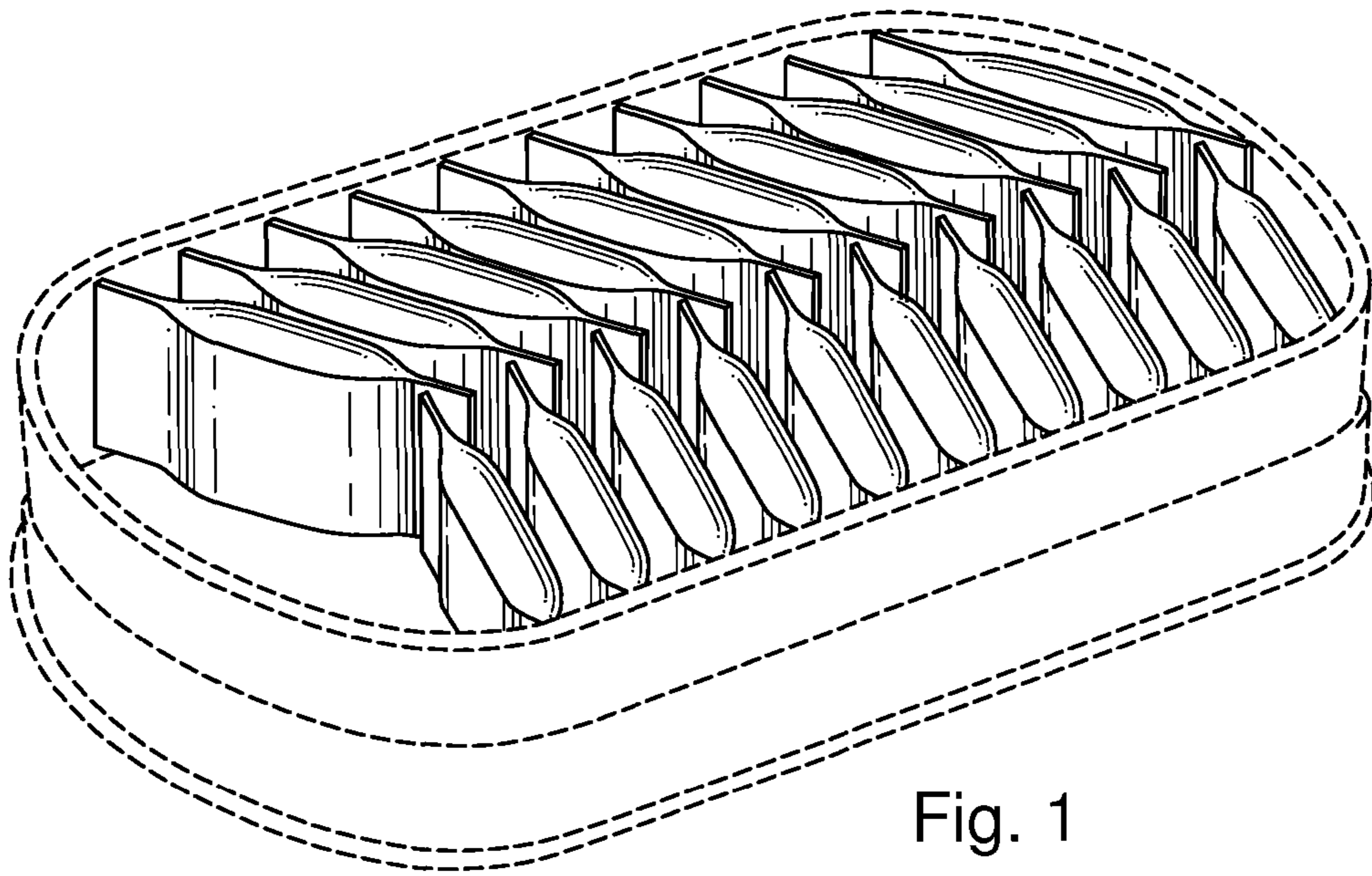

Fig. 1

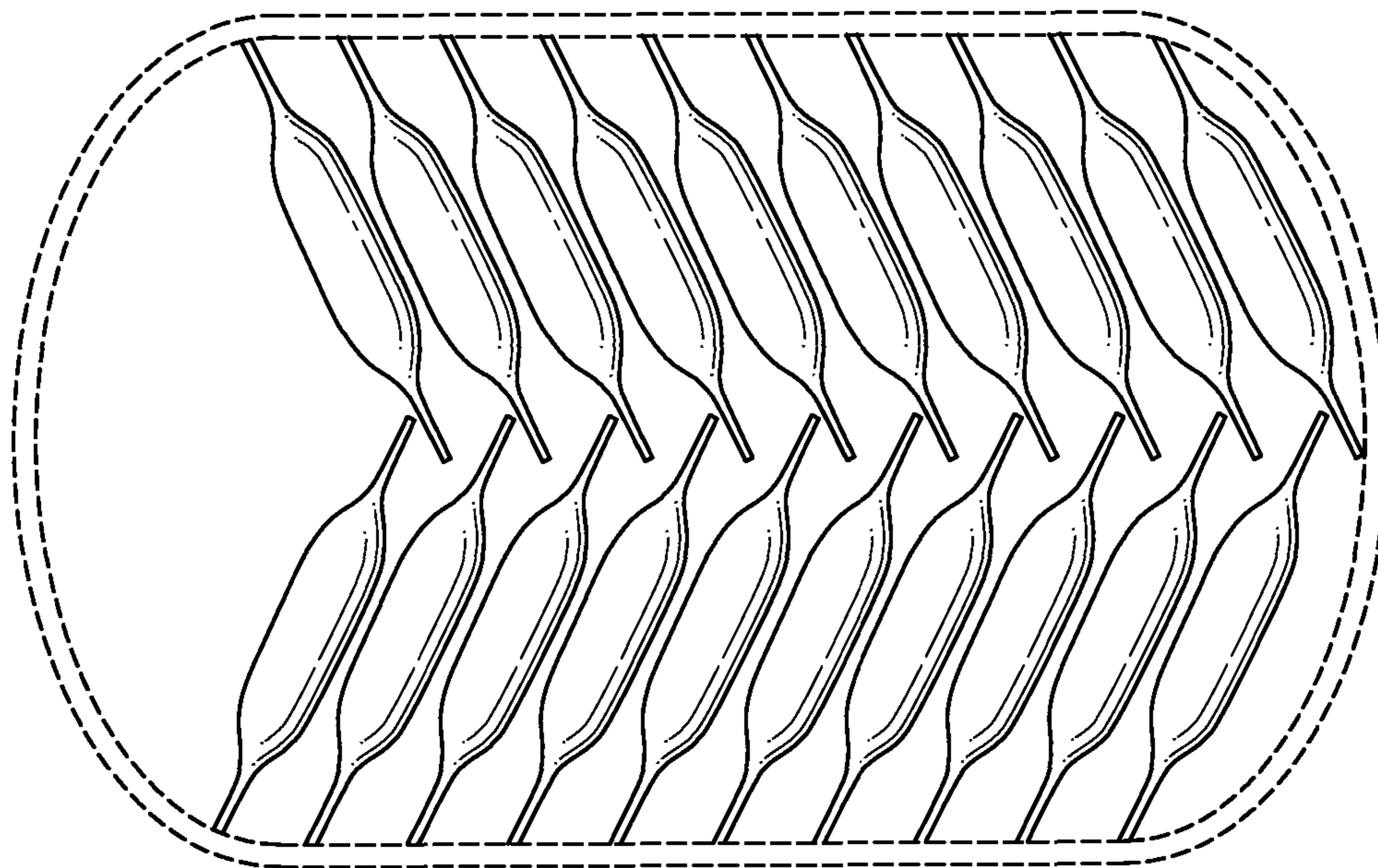

Fig. 2

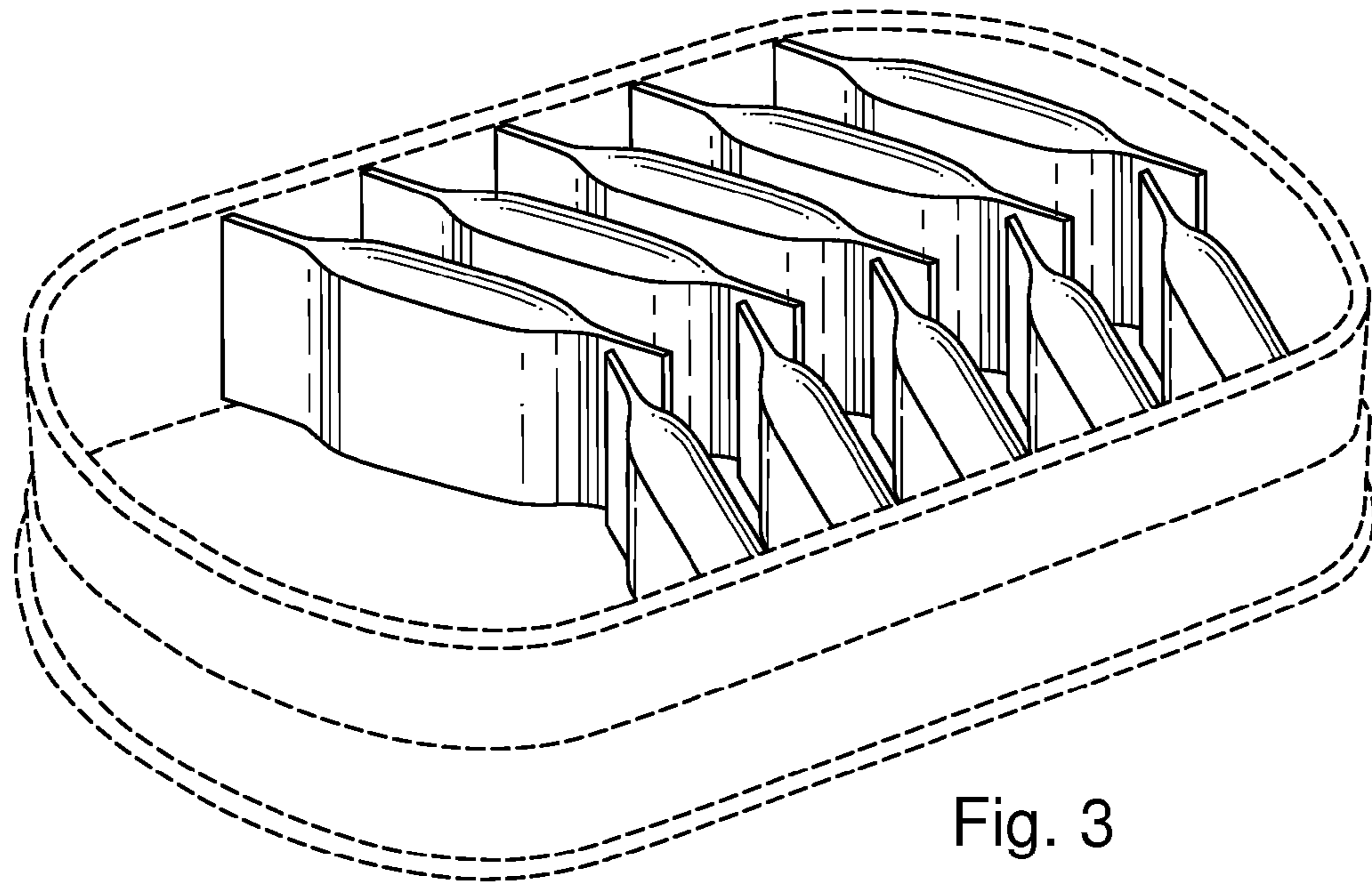

Fig. 3

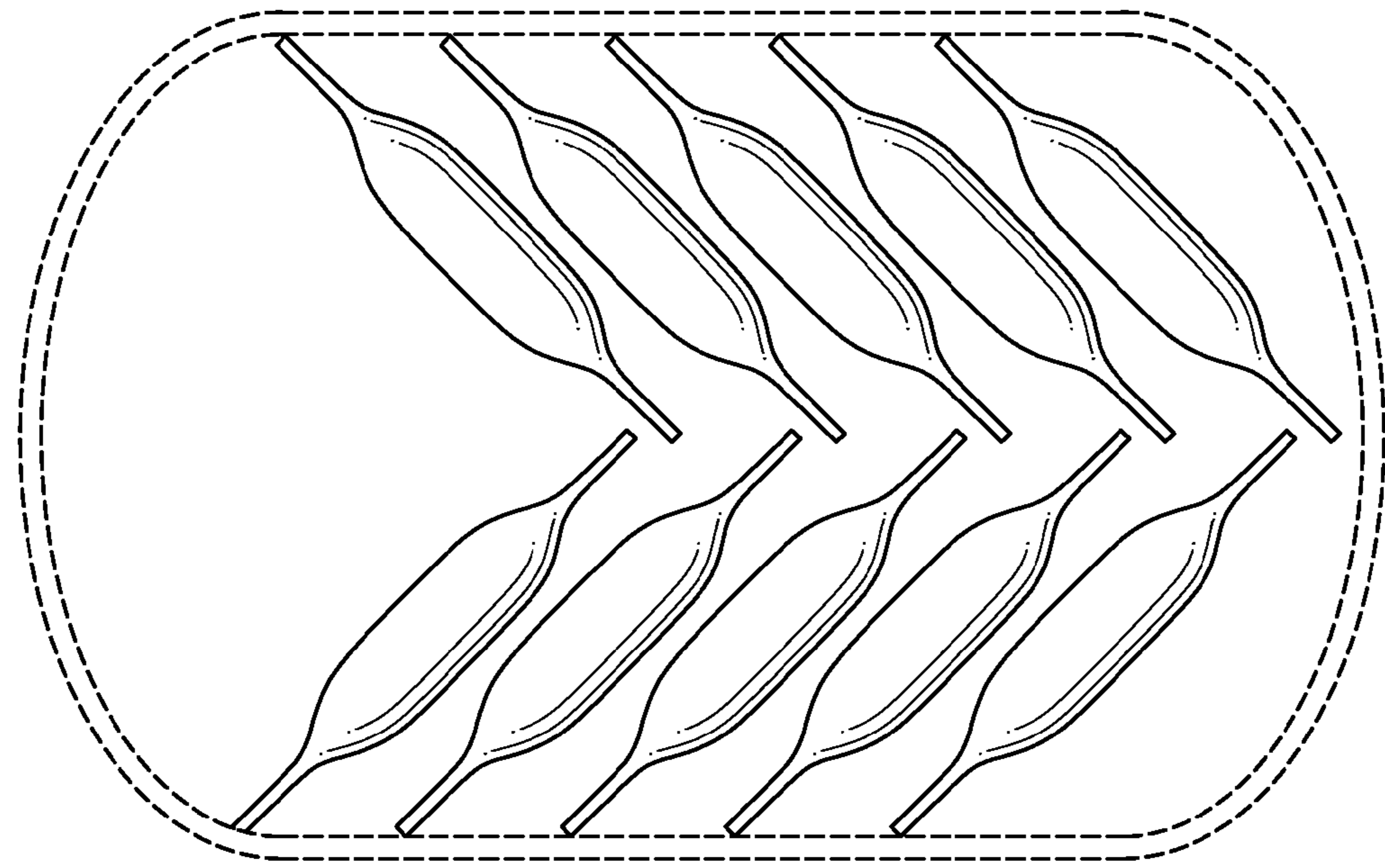

Fig. 4