



US00D665257S

(12) **United States Design Patent**
Slayton et al.

(10) **Patent No.:** **US D665,257 S**

(45) **Date of Patent:** **** Aug. 14, 2012**

(54) **FEMININE HYGIENE PRODUCT PACKAGE**

(75) Inventors: **Nancy Deters Slayton**, Springfield, OH (US); **Michelle Marie Rafie**, Cincinnati, OH (US); **Margeaux Anne Ungers**, Cincinnati, OH (US); **Laura Suzanne Dougherty**, Cincinnati, OH (US)

(73) Assignee: **The Procter & Gamble Company**, Cincinnati, OH (US)

(**) Term: **14 Years**

(21) Appl. No.: **29/342,445**

(22) Filed: **Aug. 25, 2009**

(51) **LOC (9) Cl.** **09-03**

(52) **U.S. Cl.** **D9/432**

(58) **Field of Classification Search** D9/430-434, D9/414-418, 420-423; D5/25, 56, 57, 64, D5/99, 7; D20/22, 40, 20, 23, 27; 206/278, 206/297, 299, 770, 737, 822, 457, 784, 551, 206/746; 229/100, 101, 106, 108, 101.2, 229/162.1, 992, 938

See application file for complete search history.

(56) **References Cited**

U.S. PATENT DOCUMENTS

3,464,145 A * 9/1969 Martin 446/118
4,177,305 A * 12/1979 Feingold et al. 428/13
D357,861 S * 5/1995 Sawa et al. D9/432
D553,984 S * 10/2007 Berger D9/456

D554,501 S * 11/2007 Bone et al. D9/434
D567,080 S * 4/2008 Bone et al. D9/432
D625,182 S * 10/2010 Kerr et al. D9/432
D633,150 S * 2/2011 Tesnar et al. D20/23
D635,017 S * 3/2011 Kerr et al. D9/432
D647,795 S * 11/2011 Eaton et al. D9/434

* cited by examiner

Primary Examiner — Robert M Spear

Assistant Examiner — Rashida C McCoy

(74) *Attorney, Agent, or Firm* — Amanda T. Barry

(57) **CLAIM**

The ornamental design for a feminine hygiene product package, as shown and described.

DESCRIPTION

FIG. 1 is a perspective view of a first embodiment of a feminine hygiene product package showing our new design;

FIG. 2 is a front view of the feminine hygiene product package as shown in FIG. 1;

FIG. 3 is a left side view of the feminine hygiene product package as shown in FIG. 1;

FIG. 4 is a right side view of the feminine hygiene product package as shown in FIG. 1;

FIG. 5 is a top view of the feminine hygiene product package as shown in FIG. 1;

FIG. 6 is a bottom view of the feminine hygiene product package as shown in FIG. 1; and,

FIG. 7 is a back view of the feminine hygiene product package as shown in FIG. 1.

The broken lines represent unclaimed environmental subject matter and form no part of the claimed design.

1 Claim, 5 Drawing Sheets

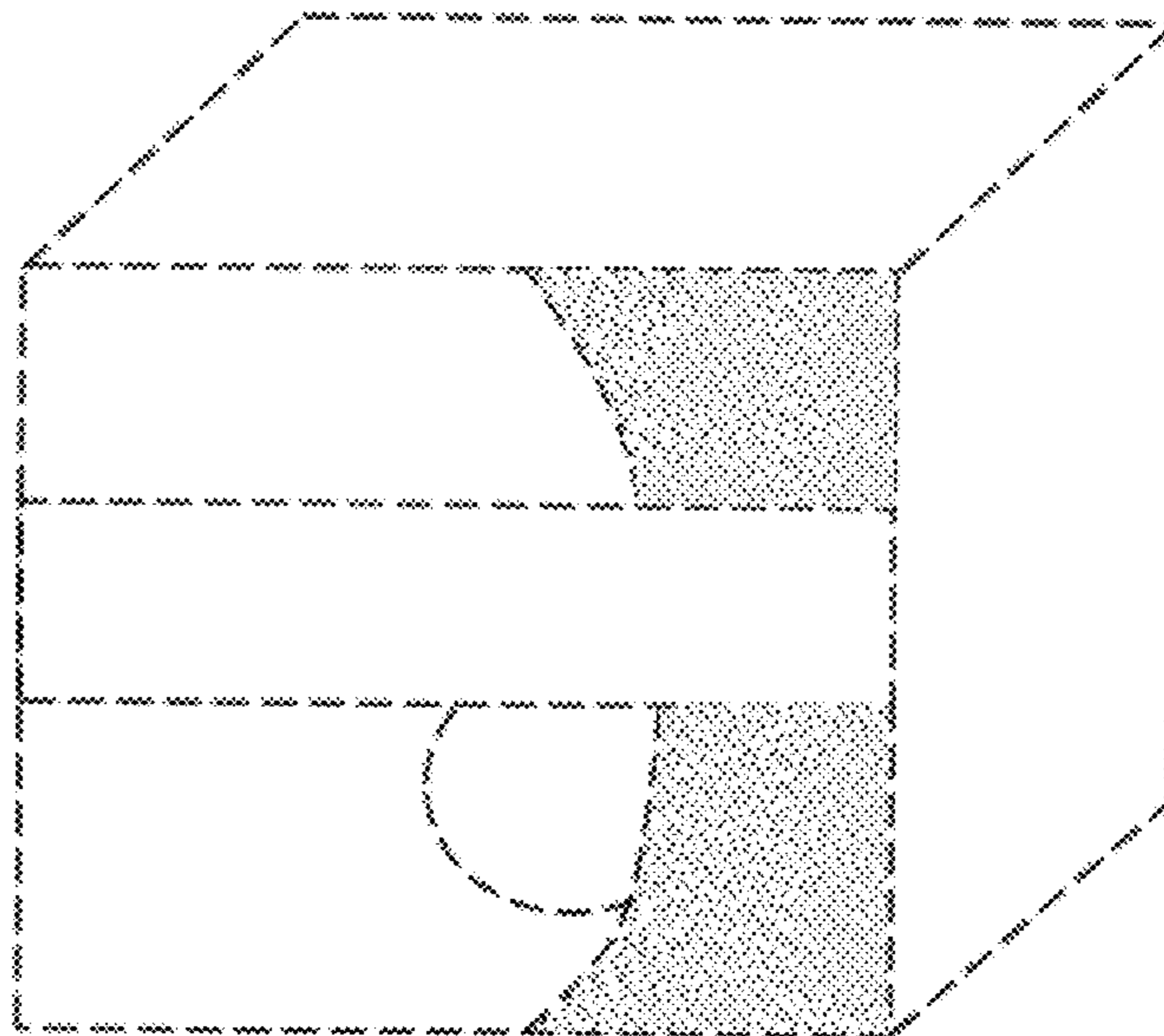

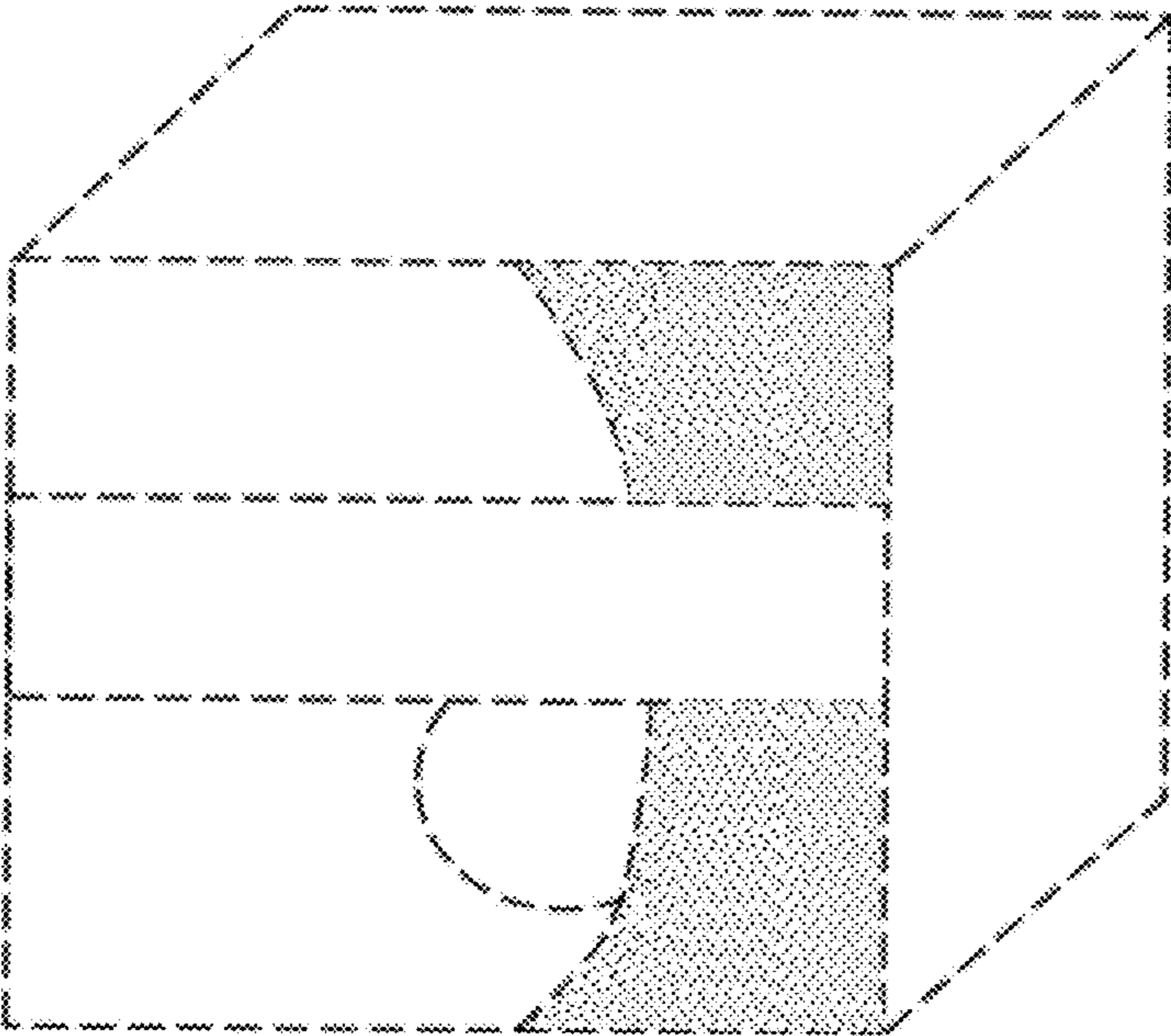

Figure 1

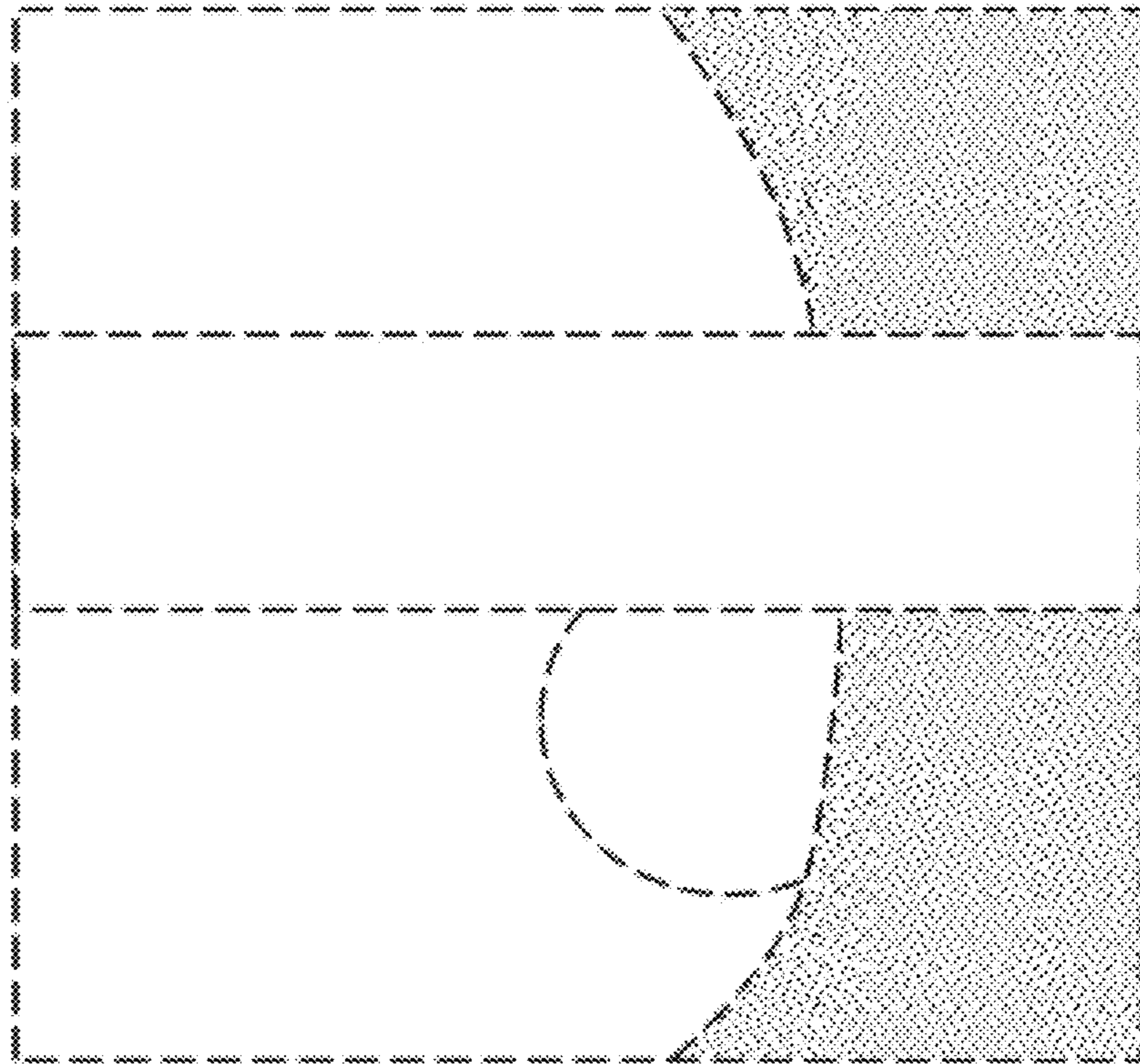

Figure 2

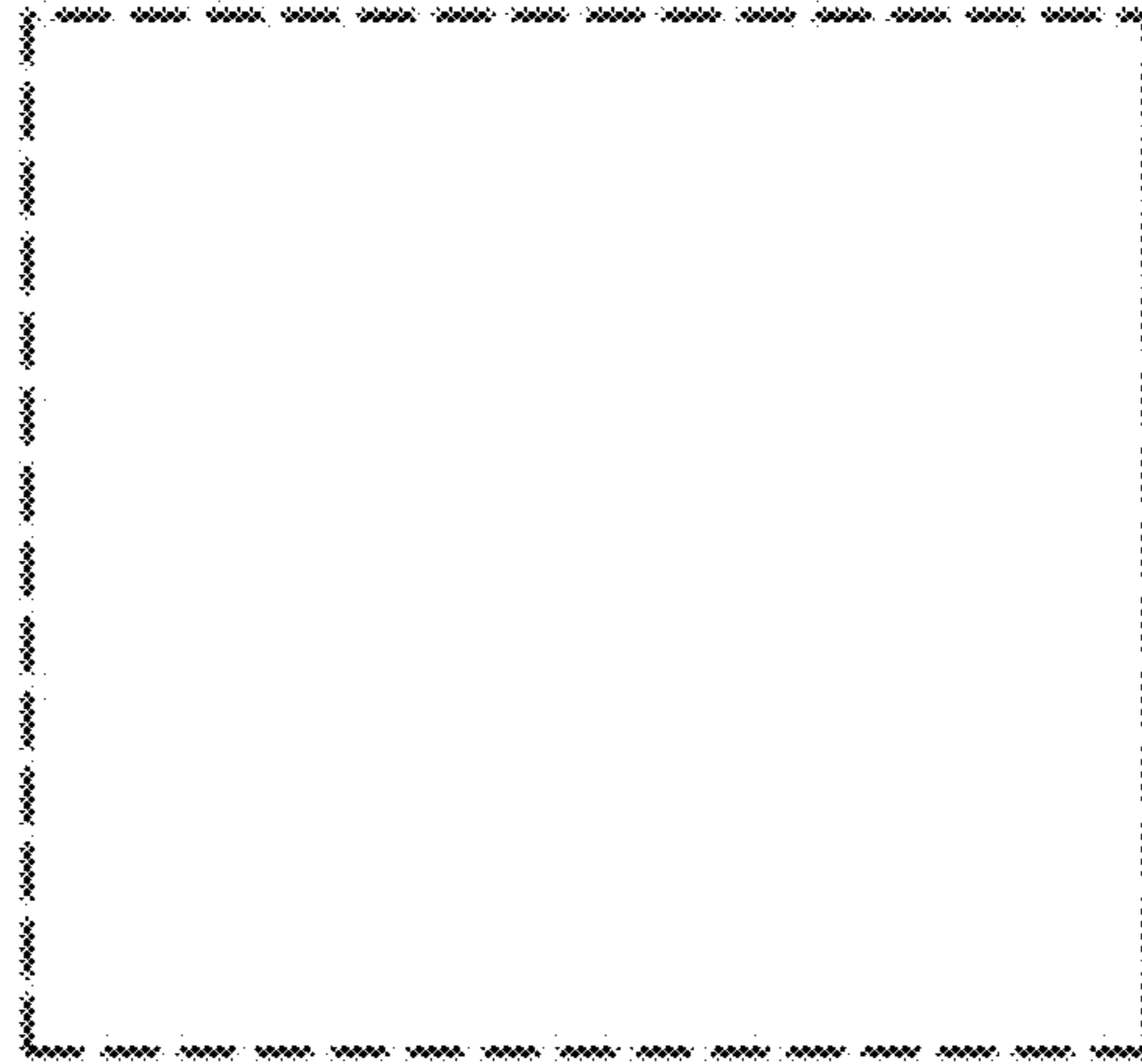

Figure 3

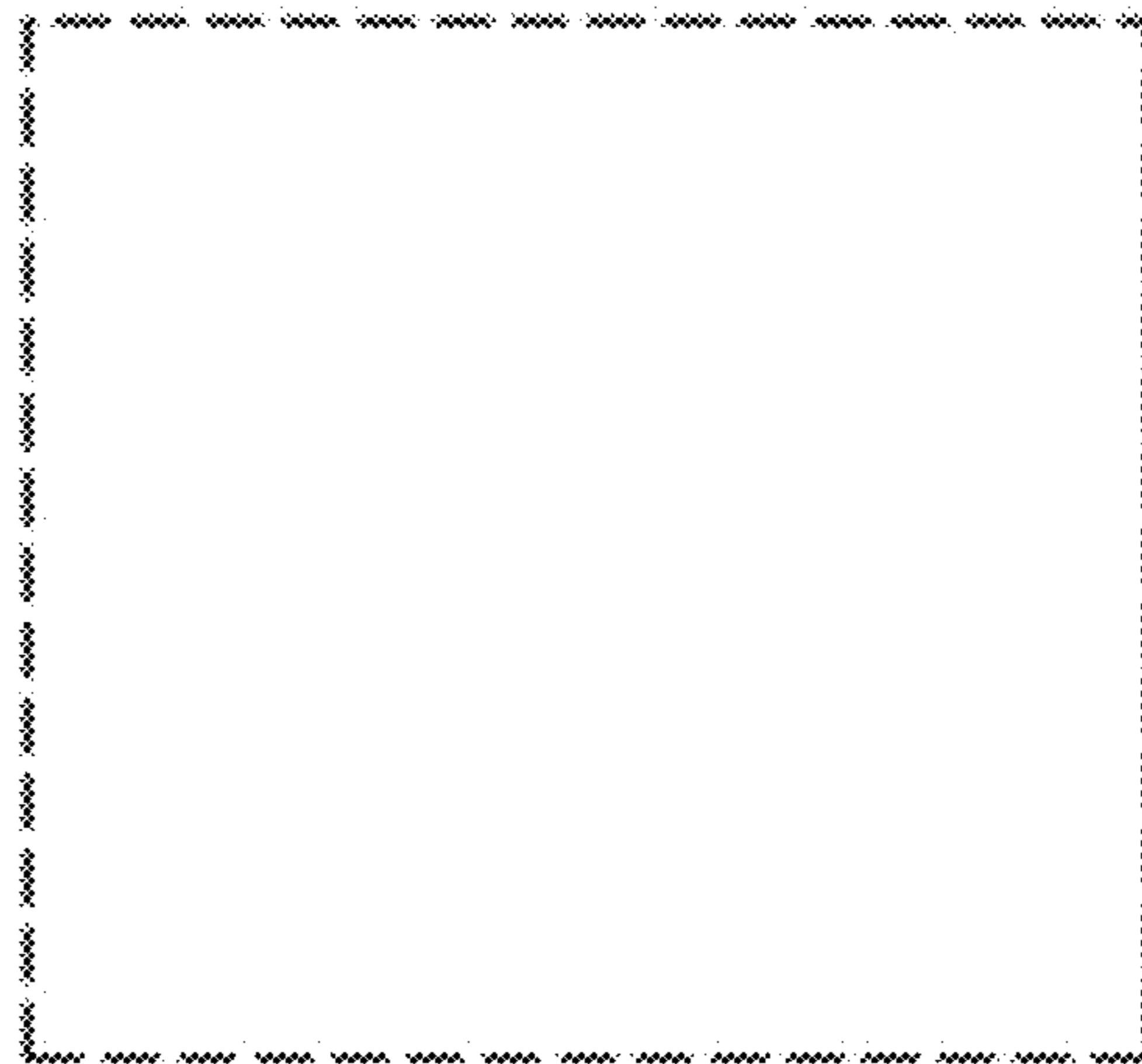

Figure 4

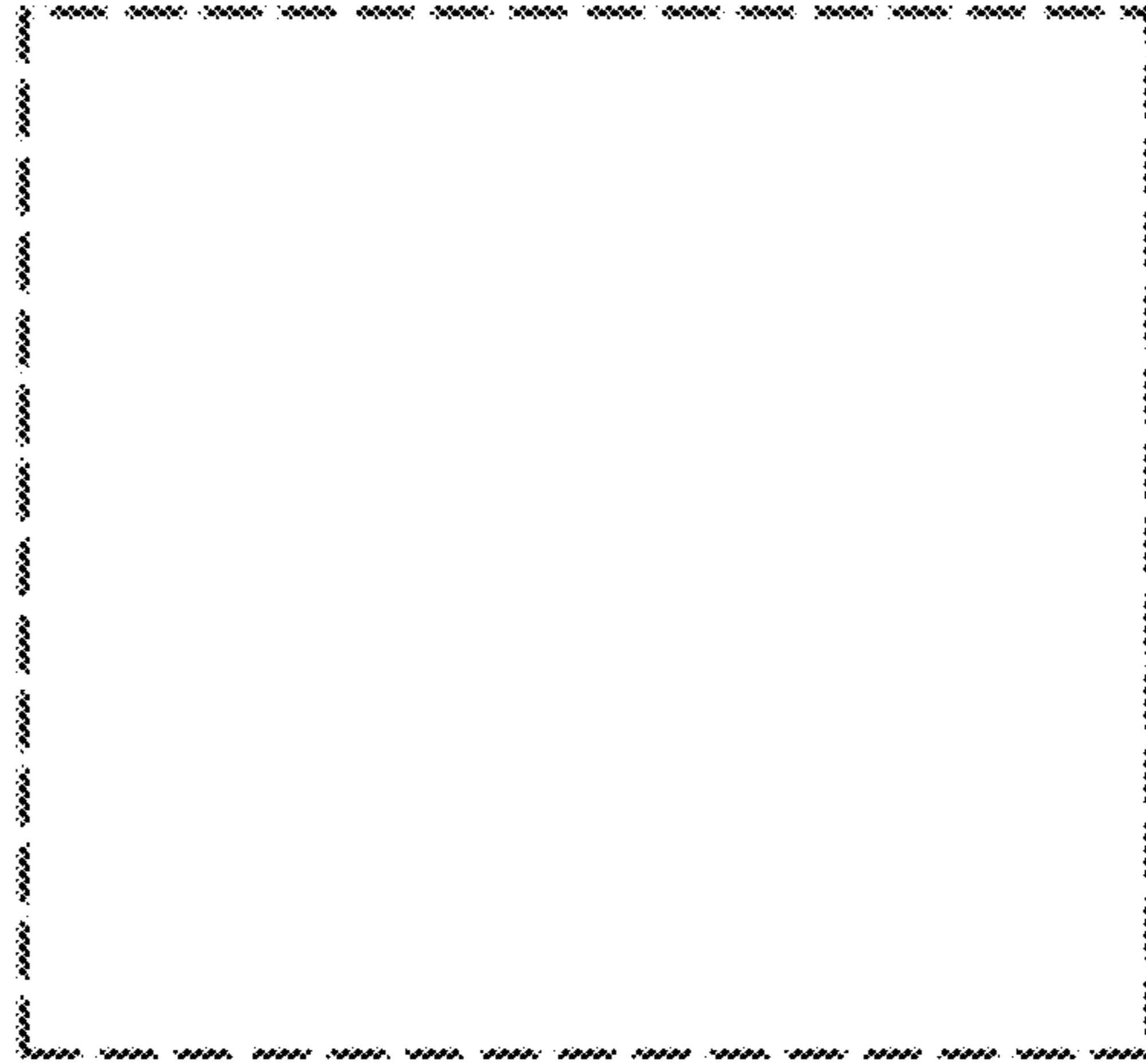

Figure 5

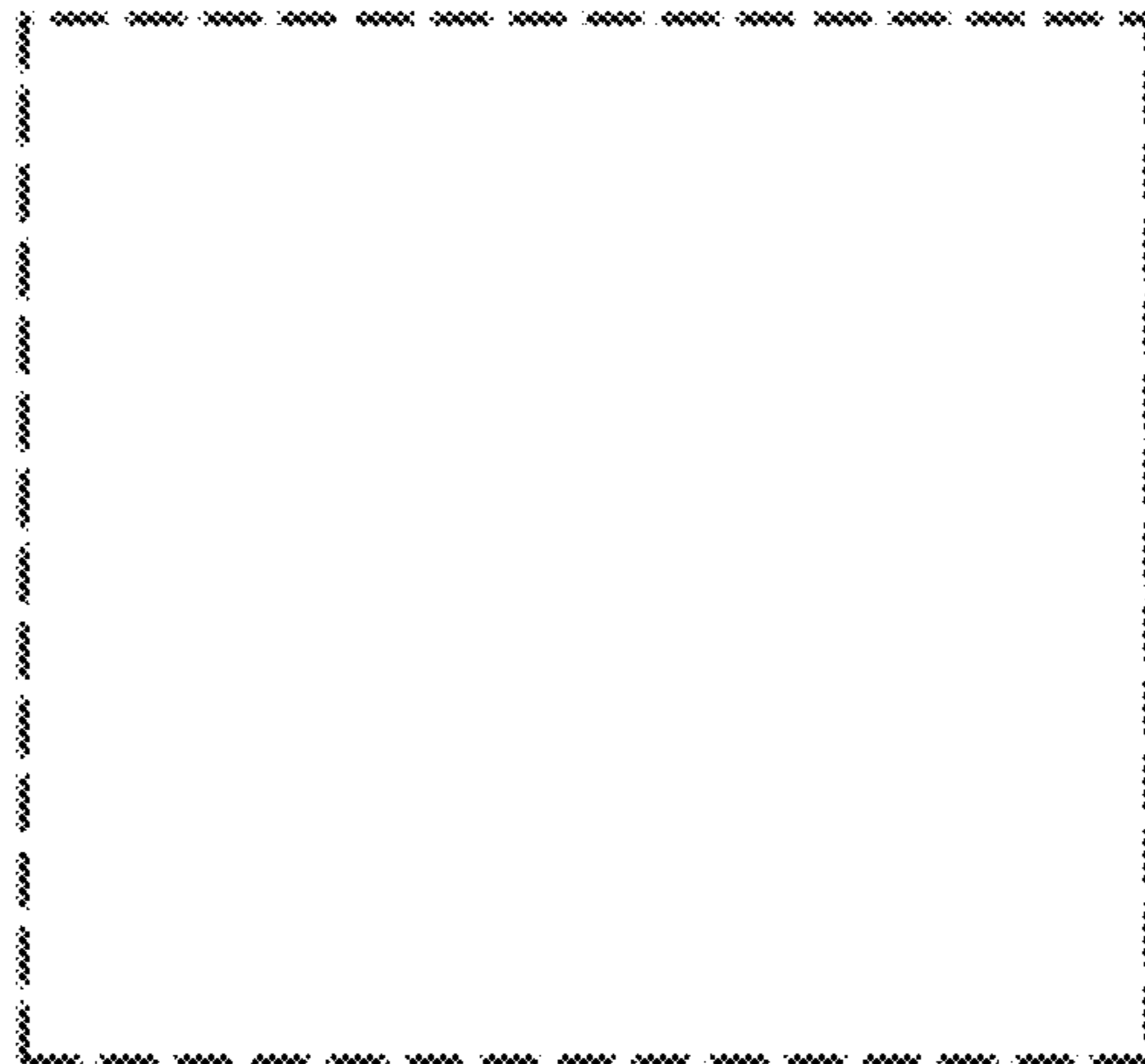

Figure 6



Figure 7