



US00D665015S

(12) **United States Design Patent**  
**Matsuno et al.**

(10) **Patent No.:** **US D665,015 S**  
(45) **Date of Patent:** **\*\* Aug. 7, 2012**

(54) **PRINTER**

(75) Inventors: **Atsuhiko Matsuno**, Azumino (JP);  
**Kenji Oshima**, Nagano (JP); **Yukiko Koshi**, Shiojiri (JP); **Ichiro Yoshioka**,  
Matsumoto (JP); **Takaaki Ishikawa**,  
Matsumoto (JP)

(73) Assignee: **Seiko Epson Corporation**, Tokyo (JP)

(\*\*) Term: **14 Years**

(21) Appl. No.: **29/390,179**

(22) Filed: **Apr. 21, 2011**

(30) **Foreign Application Priority Data**

Dec. 28, 2010 (JP) ..... 2010-031287

(51) **LOC (9) Cl.** ..... **14-02**

(52) **U.S. Cl.** ..... **D18/50**

(58) **Field of Classification Search** ..... D18/36-37,  
D18/50, 54, 54.1, 55; D14/420-425, 462-470;  
400/613, 613.1-613.4, 690.1-694

See application file for complete search history.

(56) **References Cited**

U.S. PATENT DOCUMENTS

D302,439	S	*	7/1989	Coffey et al.	.....	D18/55
D614,234	S	*	4/2010	Ishikawa et al.	.....	D18/55
D643,462	S	*	8/2011	Yamashita et al.	.....	D18/50
D648,378	S	*	11/2011	Ishikawa et al.	.....	D18/50
D648,379	S	*	11/2011	Ishikawa et al.	.....	D18/50

\* cited by examiner

*Primary Examiner* — Cathy A MacCormac

(57) **CLAIM**

The ornamental design for a printer, as shown and described.

**DESCRIPTION**

FIG. 1 is a top, front and right side perspective view of a printer showing our new design;  
FIG. 2 is a front view thereof;  
FIG. 3 is a rear view thereof;  
FIG. 4 is a top plan view thereof;  
FIG. 5 is a bottom plan view thereof;  
FIG. 6 is a right side elevational view thereof; and,  
FIG. 7 is a left side elevational view thereof.  
The broken lines are shown for illustrative purposes only and form no part of the claimed design.

**1 Claim, 3 Drawing Sheets**

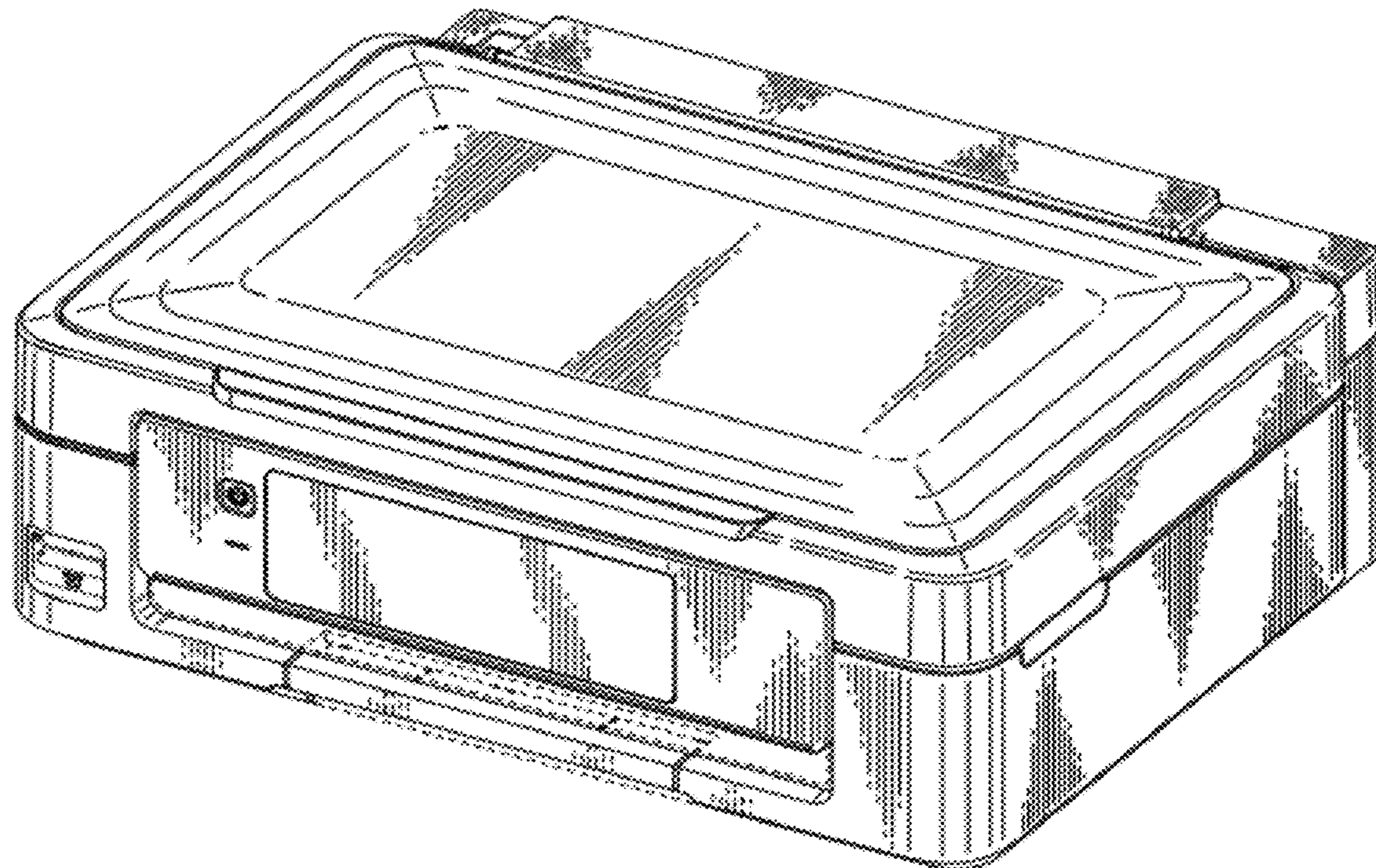

**FIG. 1**

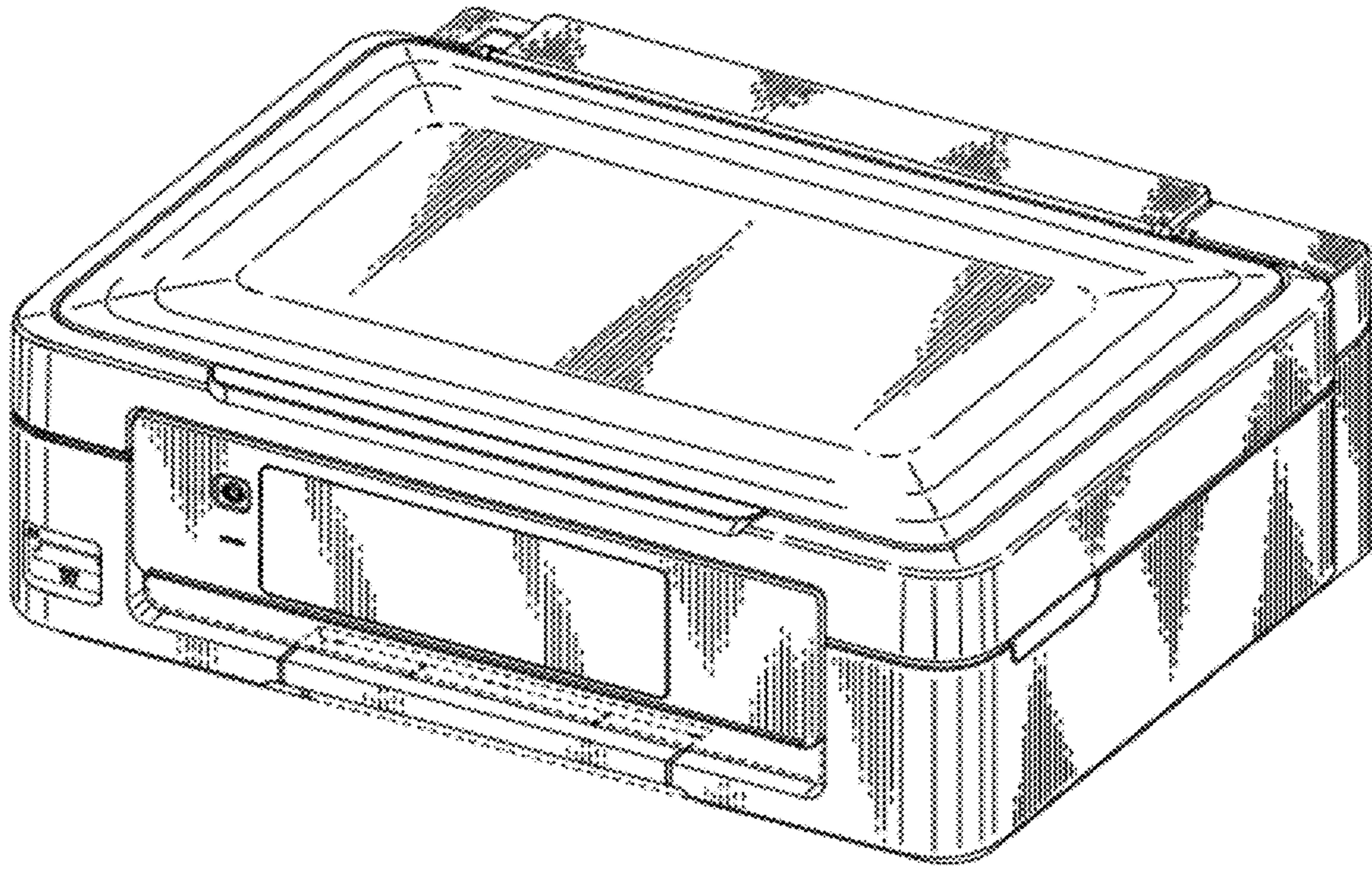

**FIG. 2**

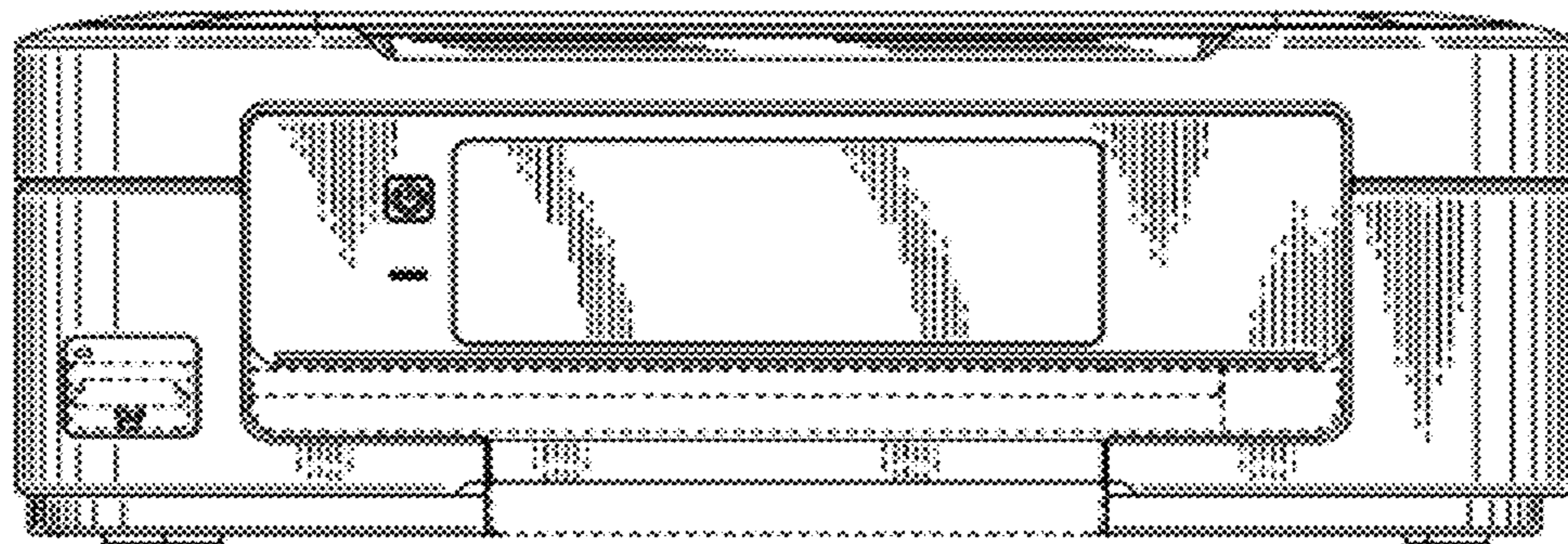

**FIG. 3**

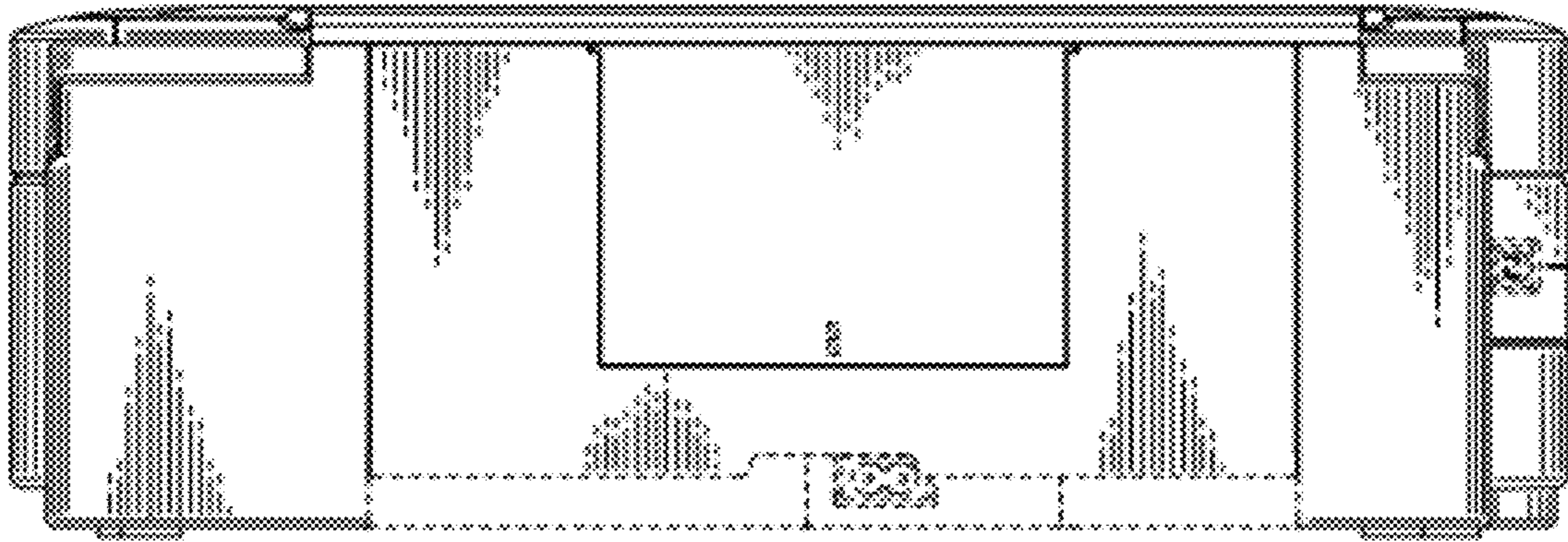

**FIG. 4**

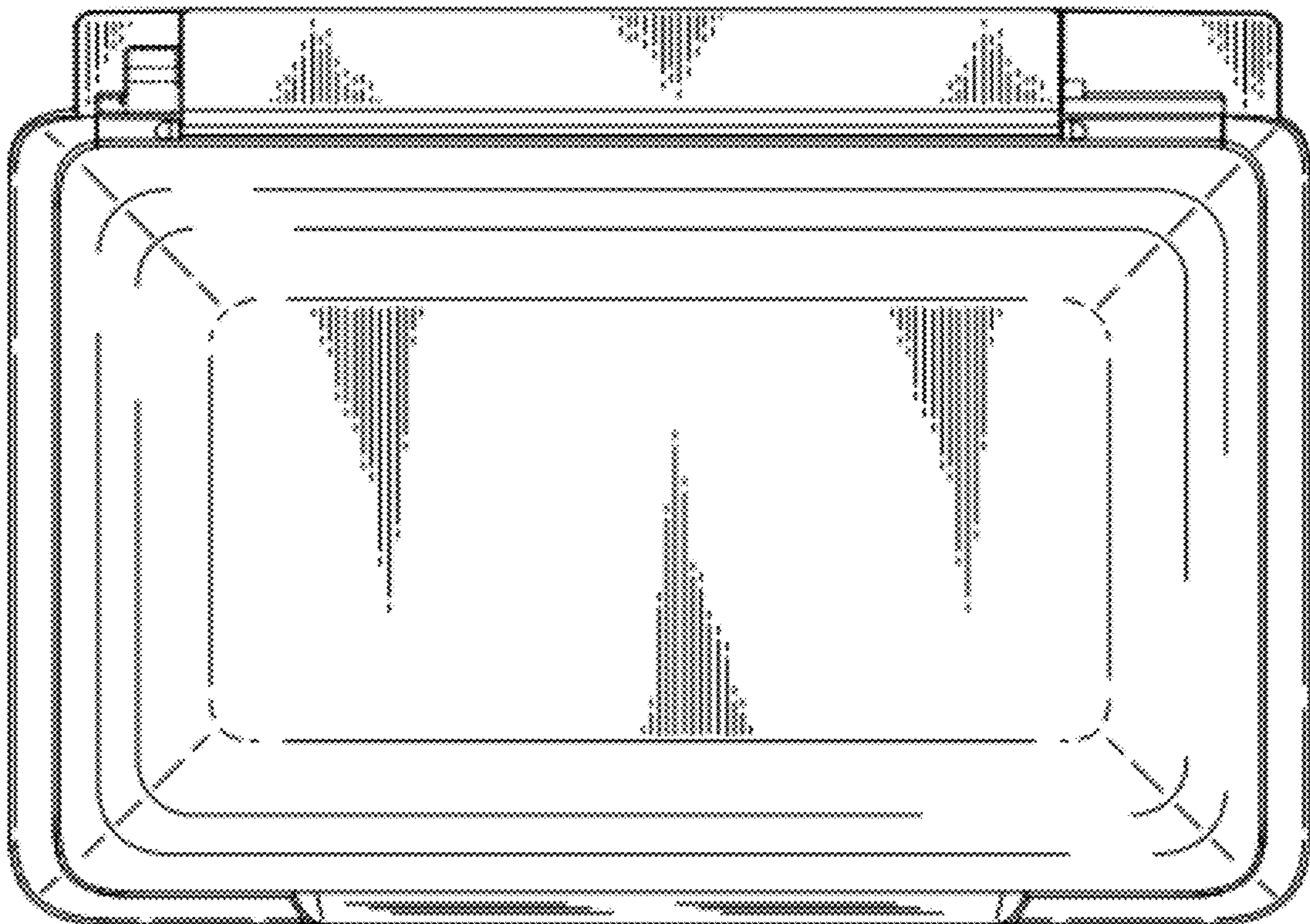

**FIG. 5**

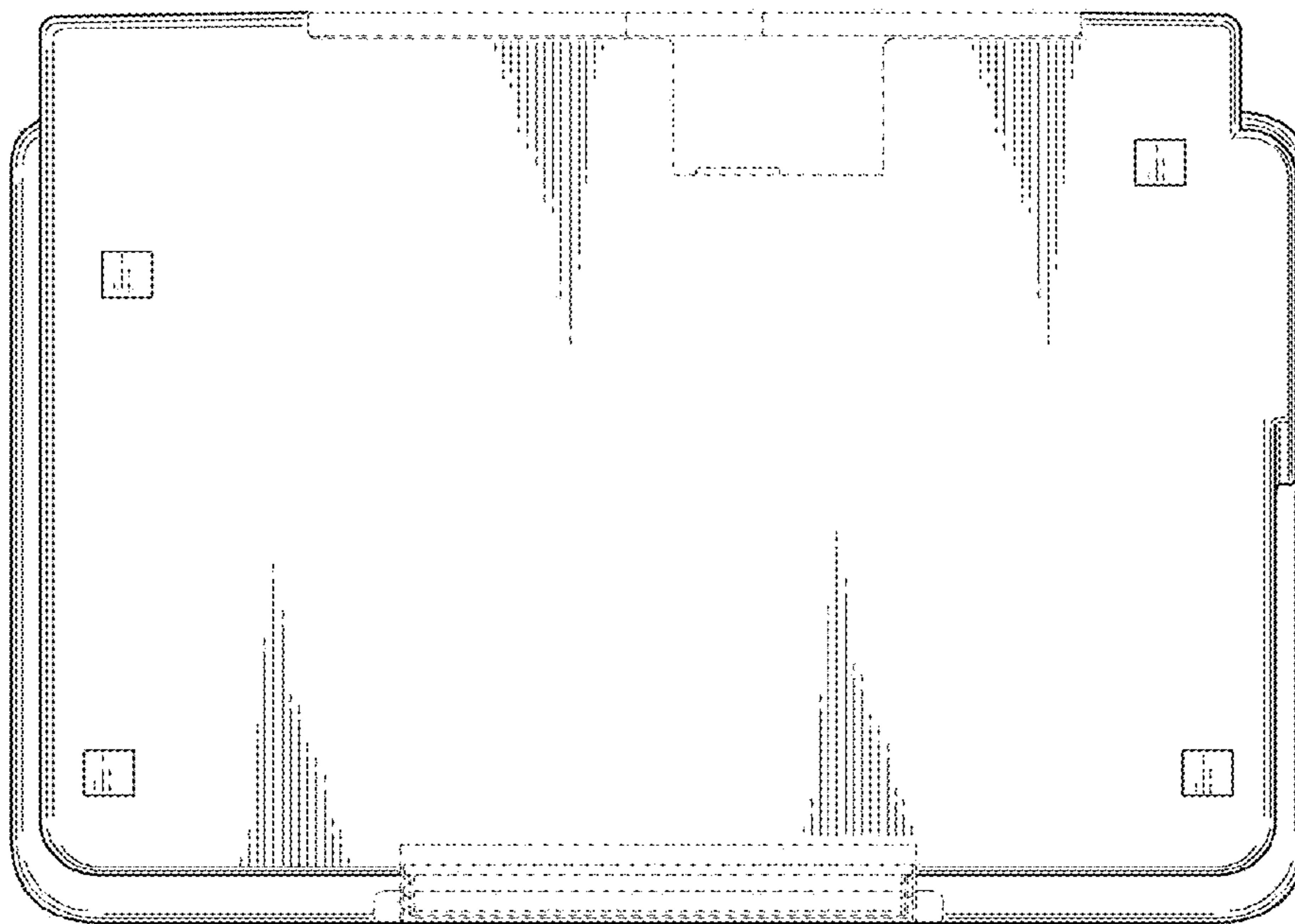

**FIG. 6**

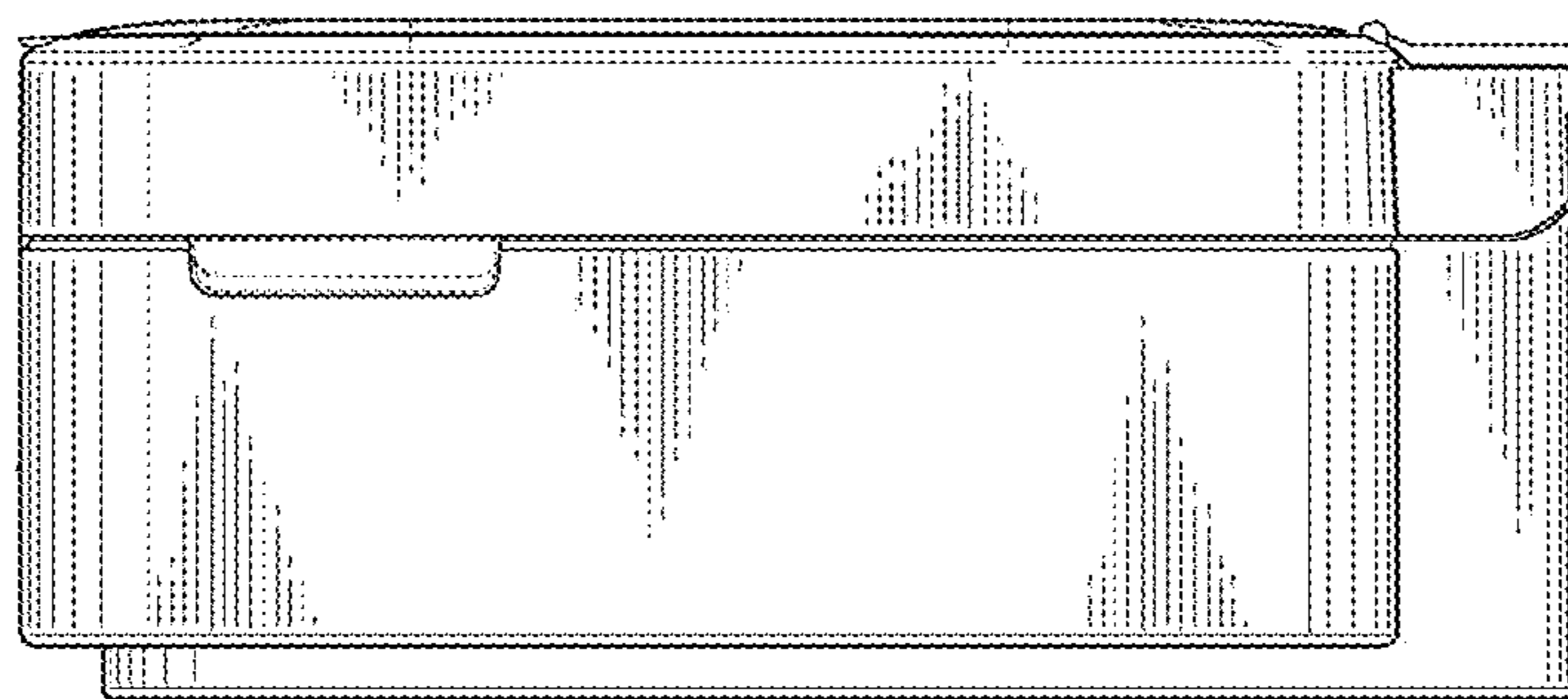

**FIG. 7**

