



US00D664906S

(12) **United States Design Patent**
Lucas

(10) **Patent No.:** **US D664,906 S**
(45) **Date of Patent:** **** Aug. 7, 2012**

(54) **MOTOR VEHICLE EXHAUST PIPE**

DESCRIPTION

(76) Inventor: **Joshua J. Lucas**, Huntington Beach, CA (US)

(**) Term: **14 Years**

(21) Appl. No.: **29/349,862**

(22) Filed: **May 12, 2010**

(51) **LOC (9) Cl.** **12-16**

(52) **U.S. Cl.** **D12/194**

(58) **Field of Classification Search** D12/194,
D12/110, 400; D15/5; 29/890.08; 60/312;
181/227, 228

See application file for complete search history.

(56) **References Cited**

U.S. PATENT DOCUMENTS

6,247,305 B1 *	6/2001	Bassani	60/312
6,382,347 B1 *	5/2002	Gerber	181/227
6,463,641 B2 *	10/2002	Bassani	29/890.08

* cited by examiner

Primary Examiner — T. Chase Nelson

Assistant Examiner — Ania Aman

(57) **CLAIM**

The ornamental design for a motor vehicle exhaust pipe, as shown and described.

FIG. 1 is a perspective view of a motor vehicle exhaust pipe embodying the inventive design, and fitted with exhaust tips and auxiliary pipes.

FIG. 2 is a front elevation view thereof.

FIG. 3 is a bottom plan view thereof.

FIG. 4 is a top plan view thereof.

FIG. 5 is a left-side elevation view thereof.

FIG. 6 is a right-side elevation view thereof.

FIG. 7 is a rear elevation view thereof.

FIG. 8 is a perspective view of the motor vehicle exhaust pipe of FIG. 1, shown without exhaust tips and auxiliary pipes; and,

FIG. 9 is a top plan view of the motor vehicle exhaust pipe of FIG. 8.

In FIGS. 1-7, the broken lines represent environmental elements shown for illustrative purposes only, and form no part of the claimed design.

In FIGS. 8, 9 the broken lines at the extremities of the shaded areas represent the bounds of the claimed design. The broken lines within the shaded areas represent environmental elements shown for illustrative purposes only, and form no part of the claimed design.

1 Claim, 8 Drawing Sheets

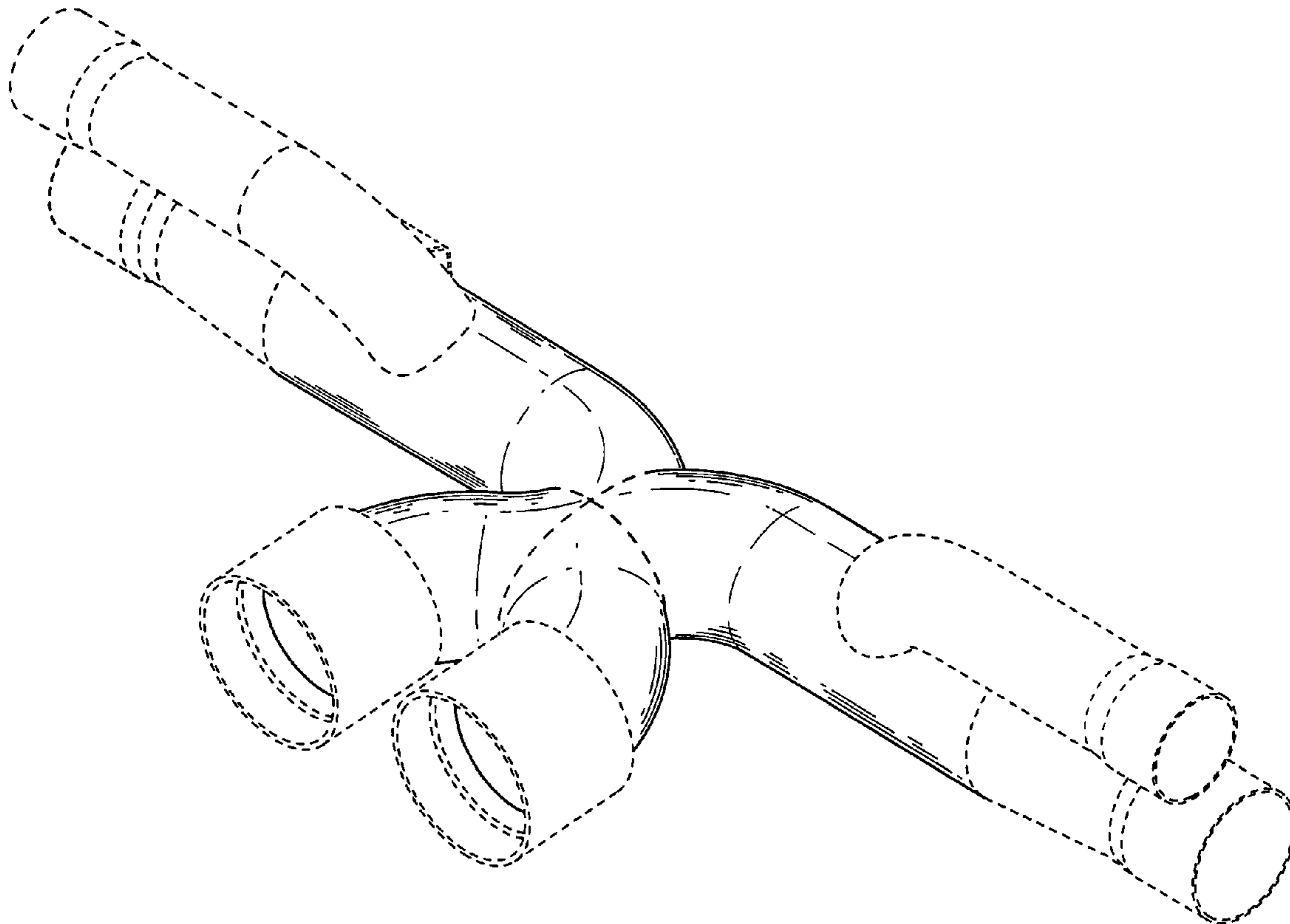

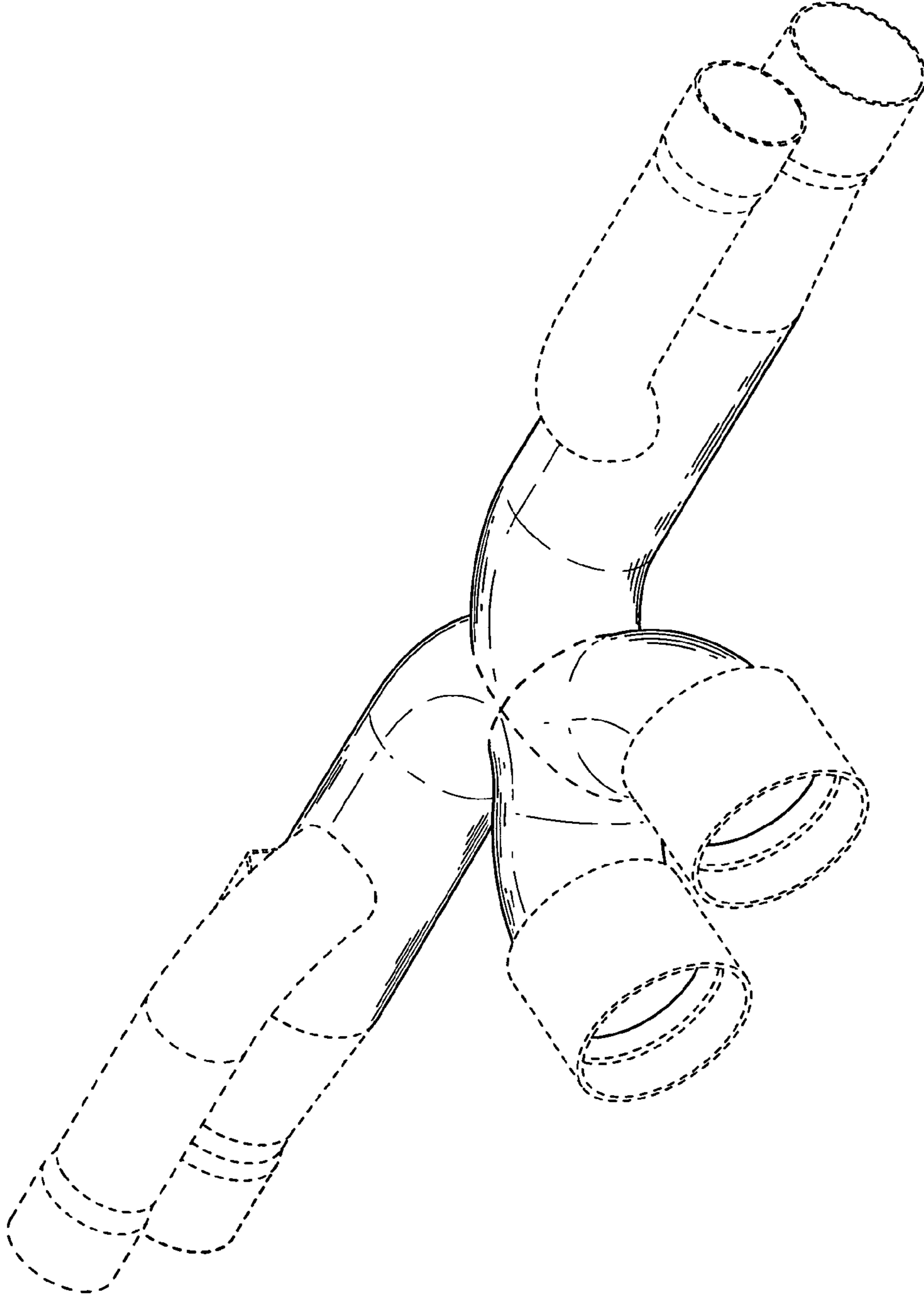

FIGURE 1

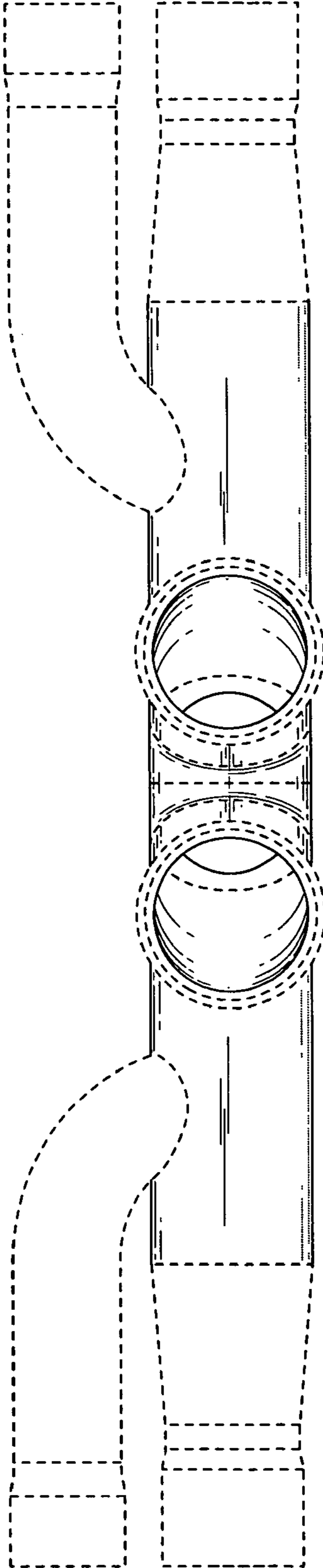

FIGURE 2

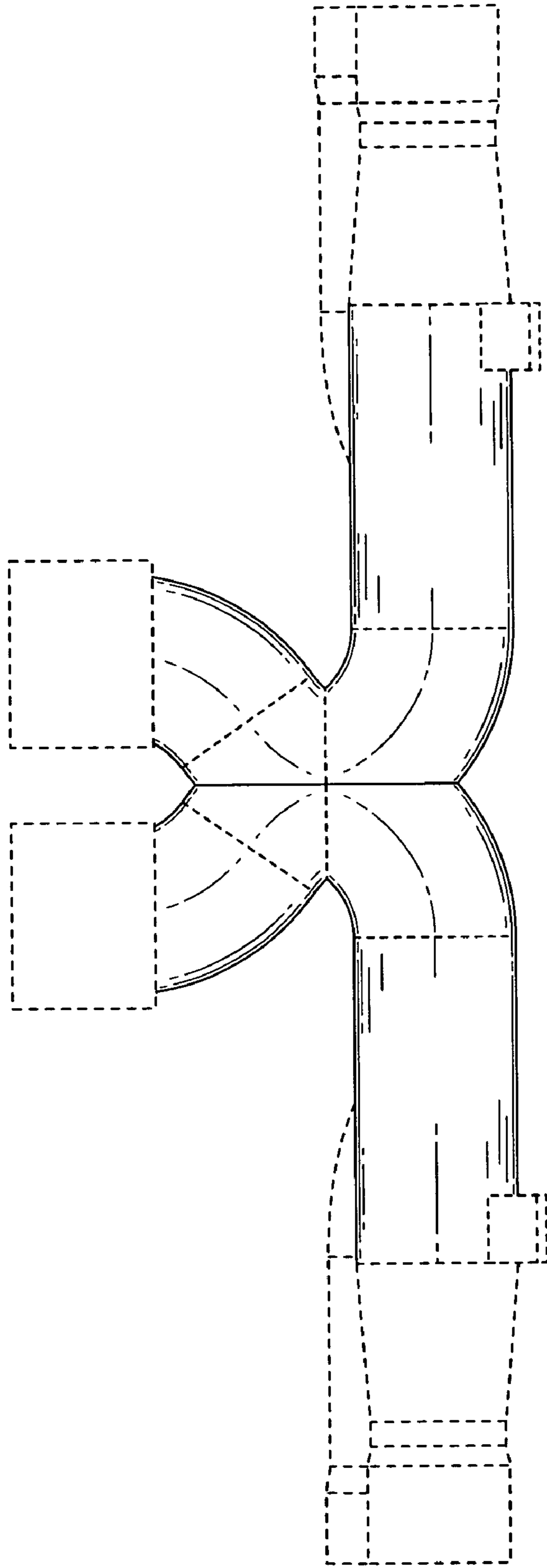

FIGURE 3

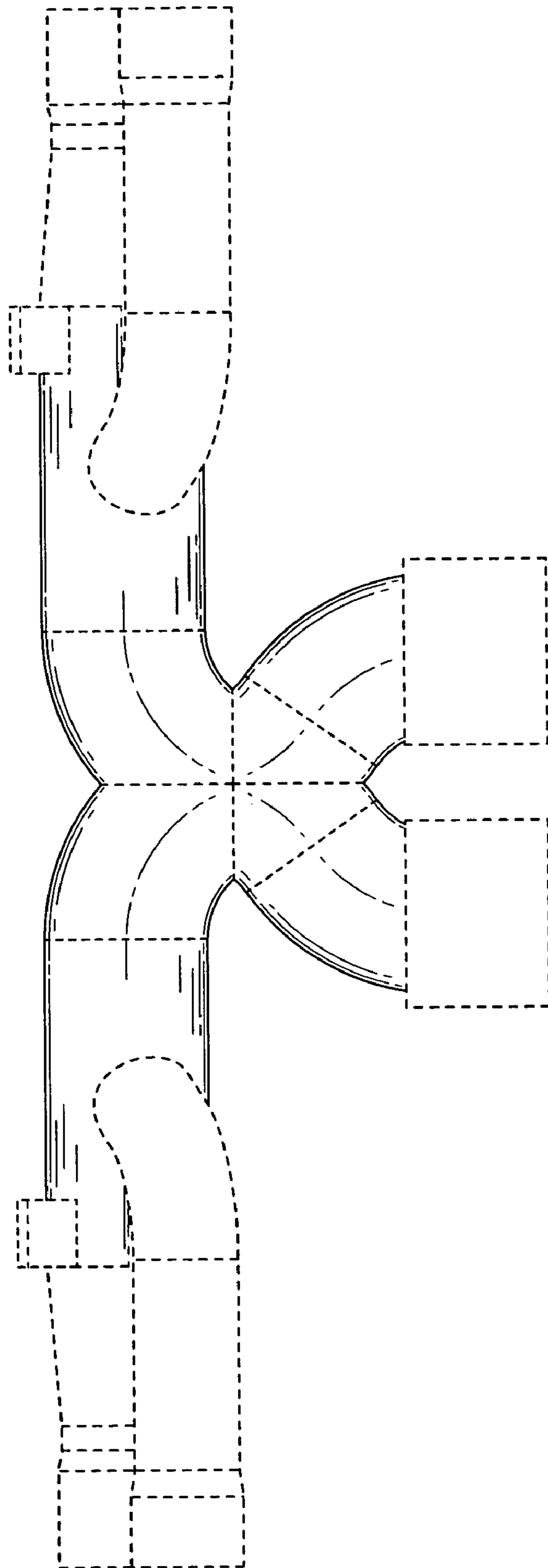

FIGURE 4

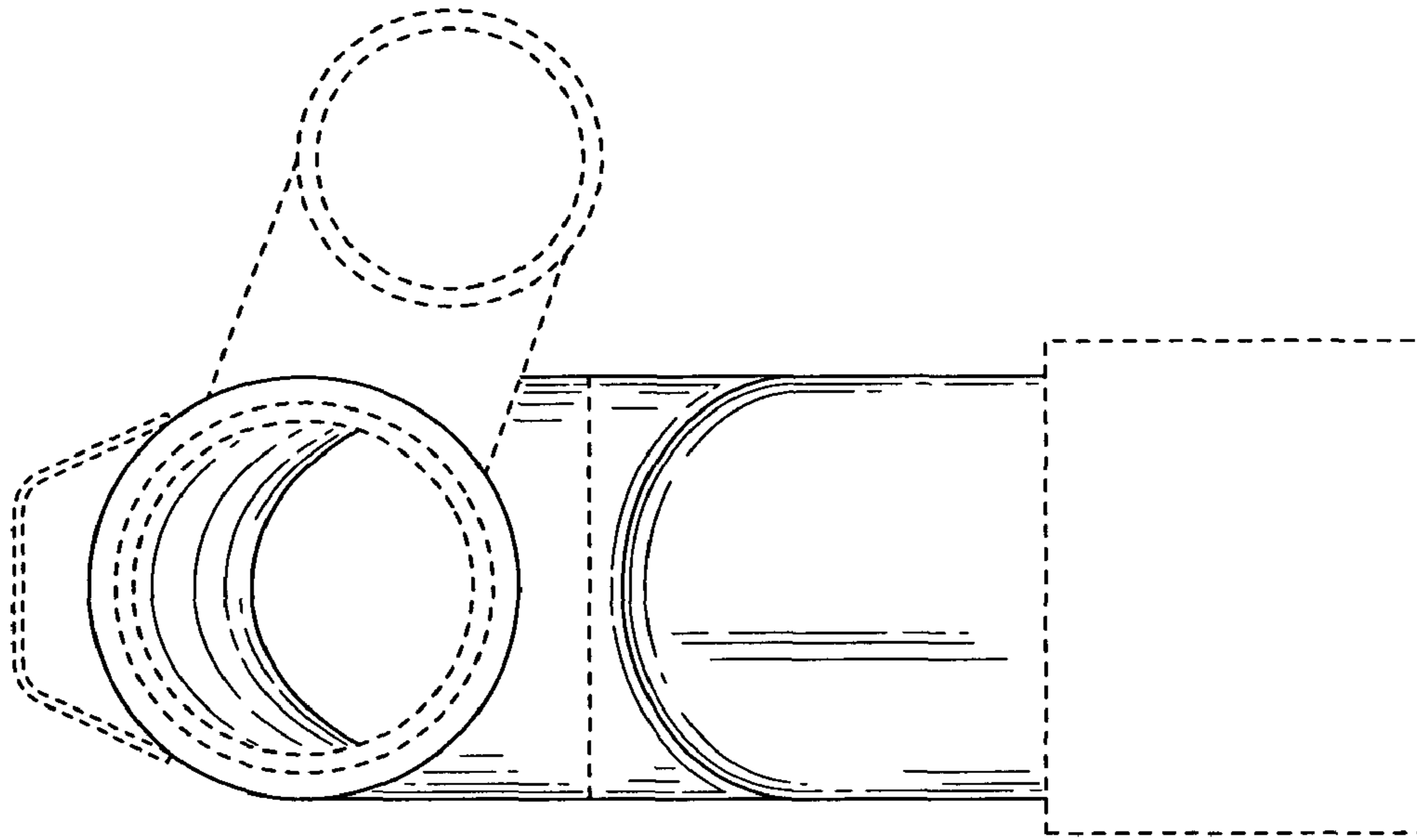

FIGURE 5

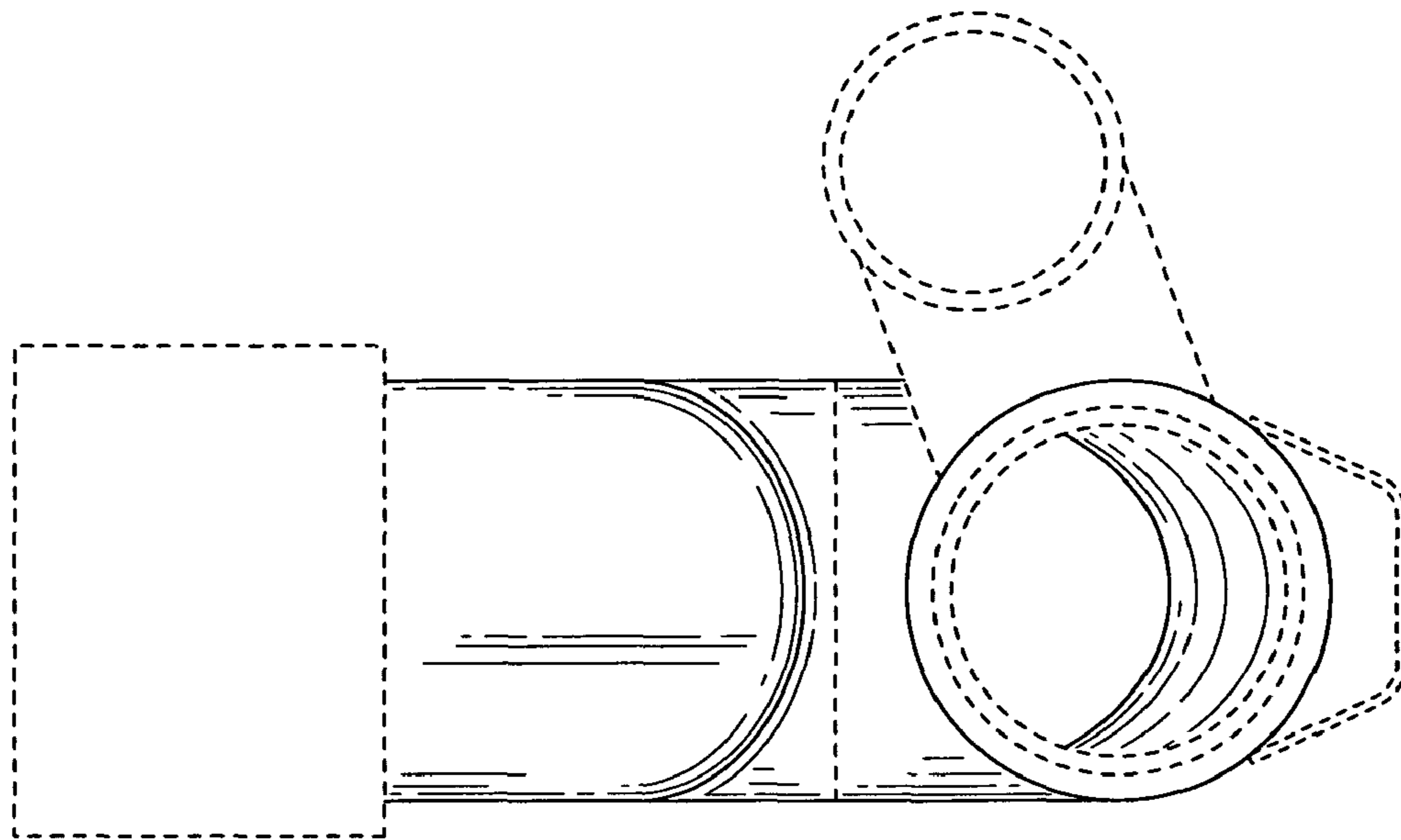

FIGURE 6

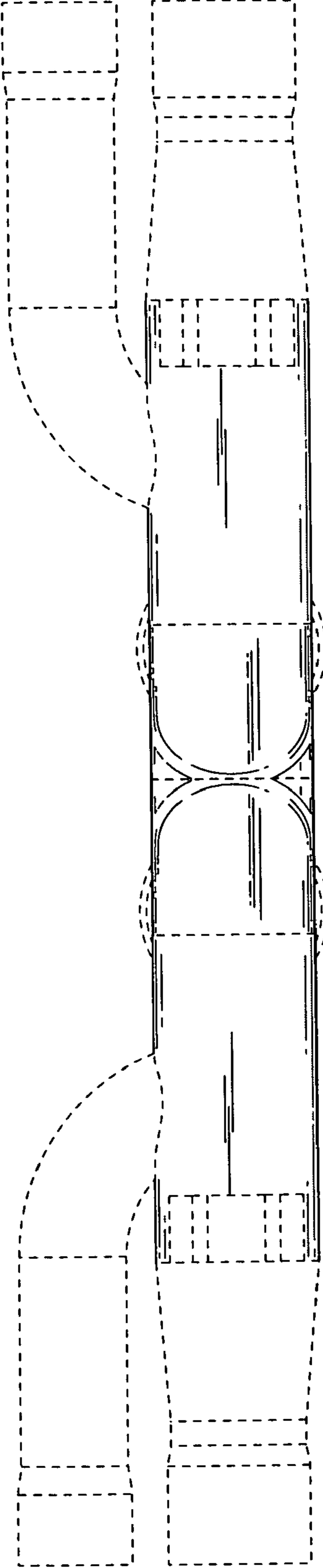

FIGURE 7

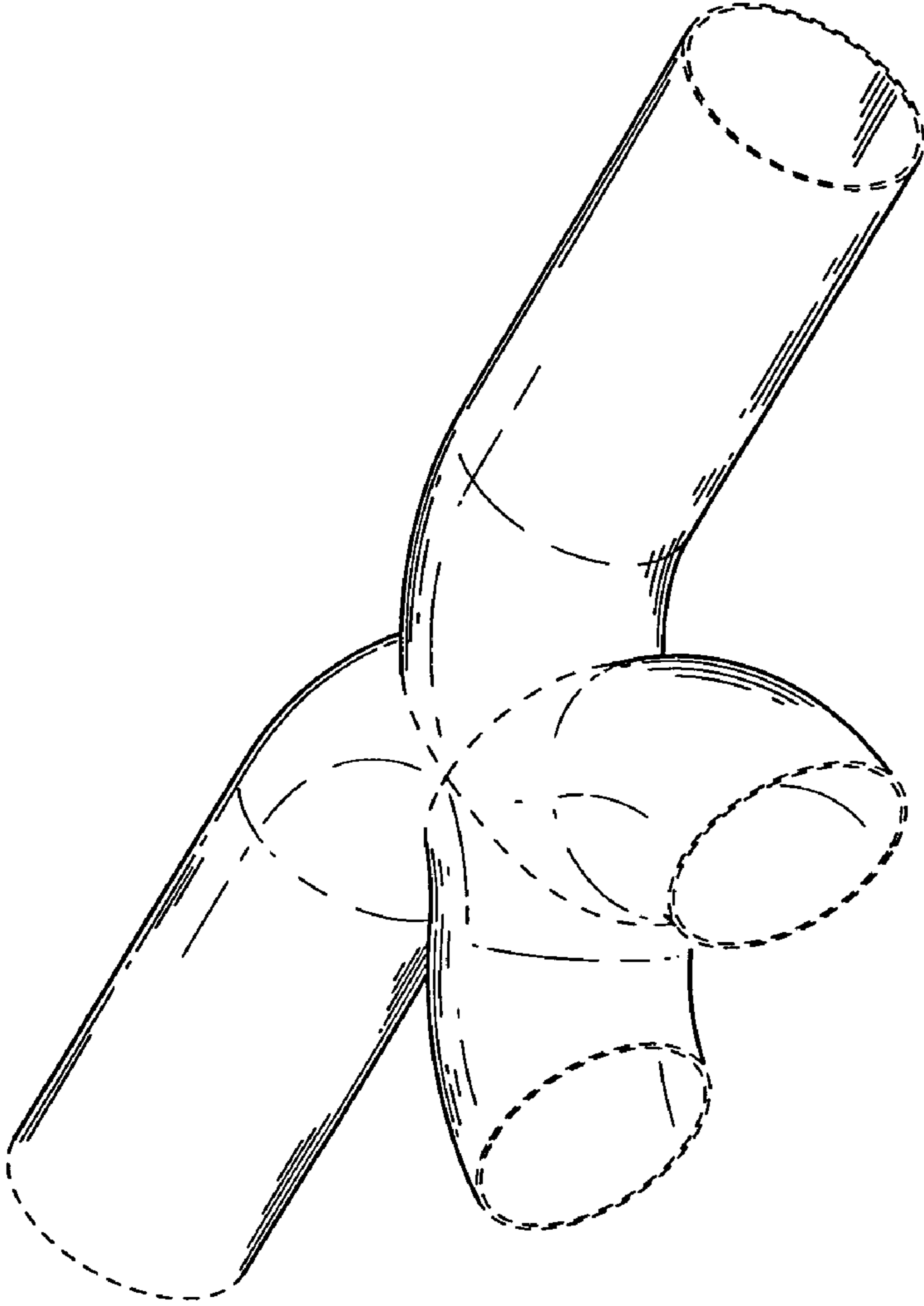

FIGURE 8

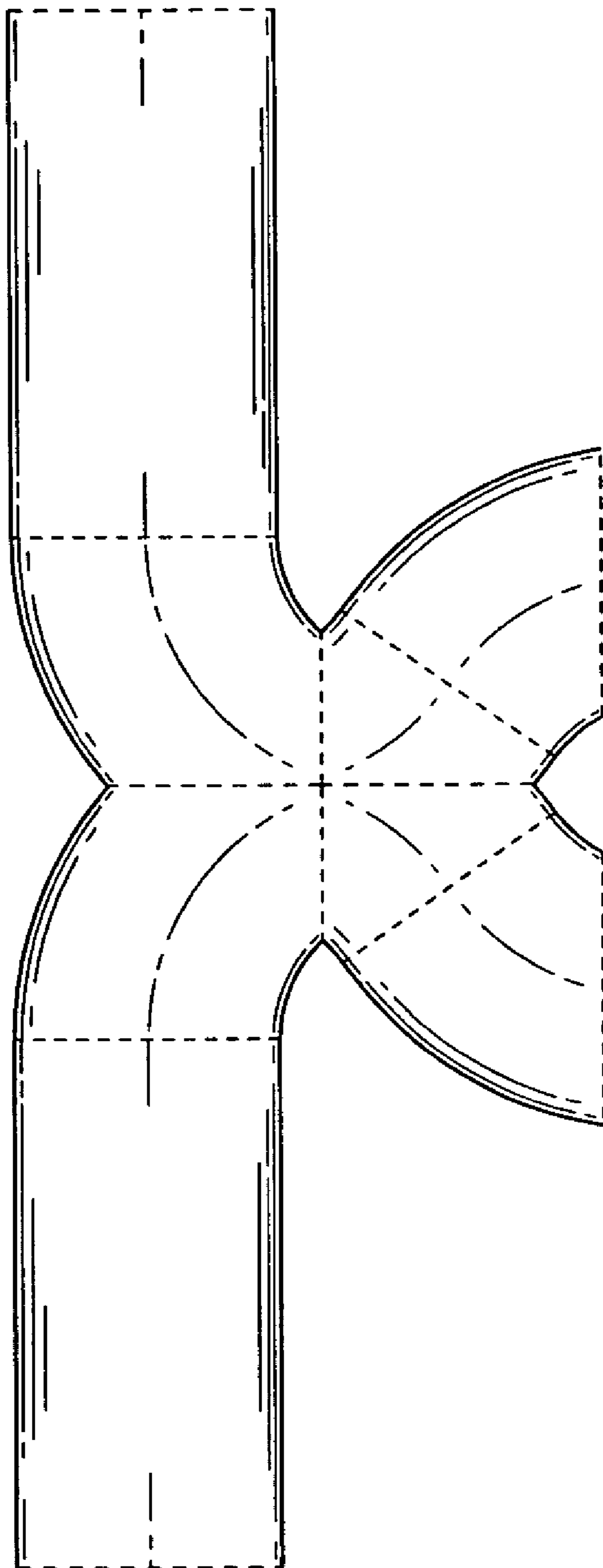

FIGURE 9