



US00D664565S

(12) **United States Design Patent**
Sonoda et al.

(10) **Patent No.:** **US D664,565 S**
(45) **Date of Patent:** **** Jul. 31, 2012**

(54) **POWER STEERING MOTOR FOR VEHICLE**

(75) Inventors: **Isao Sonoda**, Chiyoda-ku (JP);
Yoshihito Asao, Chiyoda-ku (JP);
Katsuhiko Omae, Chiyoda-ku (JP);
Satoru Akutsu, Chiyoda-ku (JP);
Mamoru Watanabe, Chiyoda-ku (JP)

(73) Assignee: **Mitsubishi Electric Corporation**,
Tokyo (JP)

(**) Term: **14 Years**

(21) Appl. No.: **29/389,203**

(22) Filed: **Apr. 7, 2011**

(30) **Foreign Application Priority Data**

Oct. 29, 2010 (JP) 2010-026024

(51) **LOC (9) Cl.** **15-01**

(52) **U.S. Cl.** **D15/5**

(58) **Field of Classification Search** D15/1-6;
D12/177; 180/444

See application file for complete search history.

(56) **References Cited**

U.S. PATENT DOCUMENTS

| | | | | | |
|--------------|------|---------|-----------------|-------|------------|
| D589,858 | S * | 4/2009 | Nagase et al. | | D12/177 |
| 2007/0256887 | A1 * | 11/2007 | Hirakawa et al. | | 180/444 |
| 2009/0260914 | A1 * | 10/2009 | Streng et al. | | 180/444 |
| 2010/0295498 | A1 * | 11/2010 | Tominaga et al. | | 318/689 |
| 2010/0319471 | A1 * | 12/2010 | Nam et al. | | 74/89.23 |
| 2011/0011667 | A1 * | 1/2011 | Kang | | 180/444 |
| 2011/0088488 | A1 * | 4/2011 | Maehara | | 73/862.333 |

2011/0155499 A1* 6/2011 Wilkes et al. 180/444
2011/0242773 A1* 10/2011 Tani 361/748
2011/0266928 A1* 11/2011 Shiino et al. 310/68 R

* cited by examiner

Primary Examiner — T. Chase Nelson

Assistant Examiner — Ania Aman

(74) *Attorney, Agent, or Firm* — Sughrue Mion, PLLC

(57) **CLAIM**

The ornamental design for a power steering motor for vehicle, as shown and described.

DESCRIPTION

FIG. 1 is a front, top and right side perspective view of a power steering motor for vehicle, showing our new design; FIG. 2 is a front elevational view thereof; FIG. 3 is a rear elevational view thereof; FIG. 4 is a left side elevational view thereof; FIG. 5 is a right side elevational view thereof; FIG. 6 is a top plan view thereof; FIG. 7 is a bottom plan view thereof; FIG. 8 is a reference perspective view with a connector 01 installed; FIG. 9 is a reference perspective view with a connector 02 installed; FIG. 10 is a reference perspective view with a connector 03 installed; FIG. 11 is a reference perspective view with a connector 04 installed; FIG. 12 is a reference view with change connection part 01; and, FIG. 13 is a reference view with change connection part 02. The broken lines are for illustrating environmental structure only and form no part of the claimed design.

1 Claim, 13 Drawing Sheets

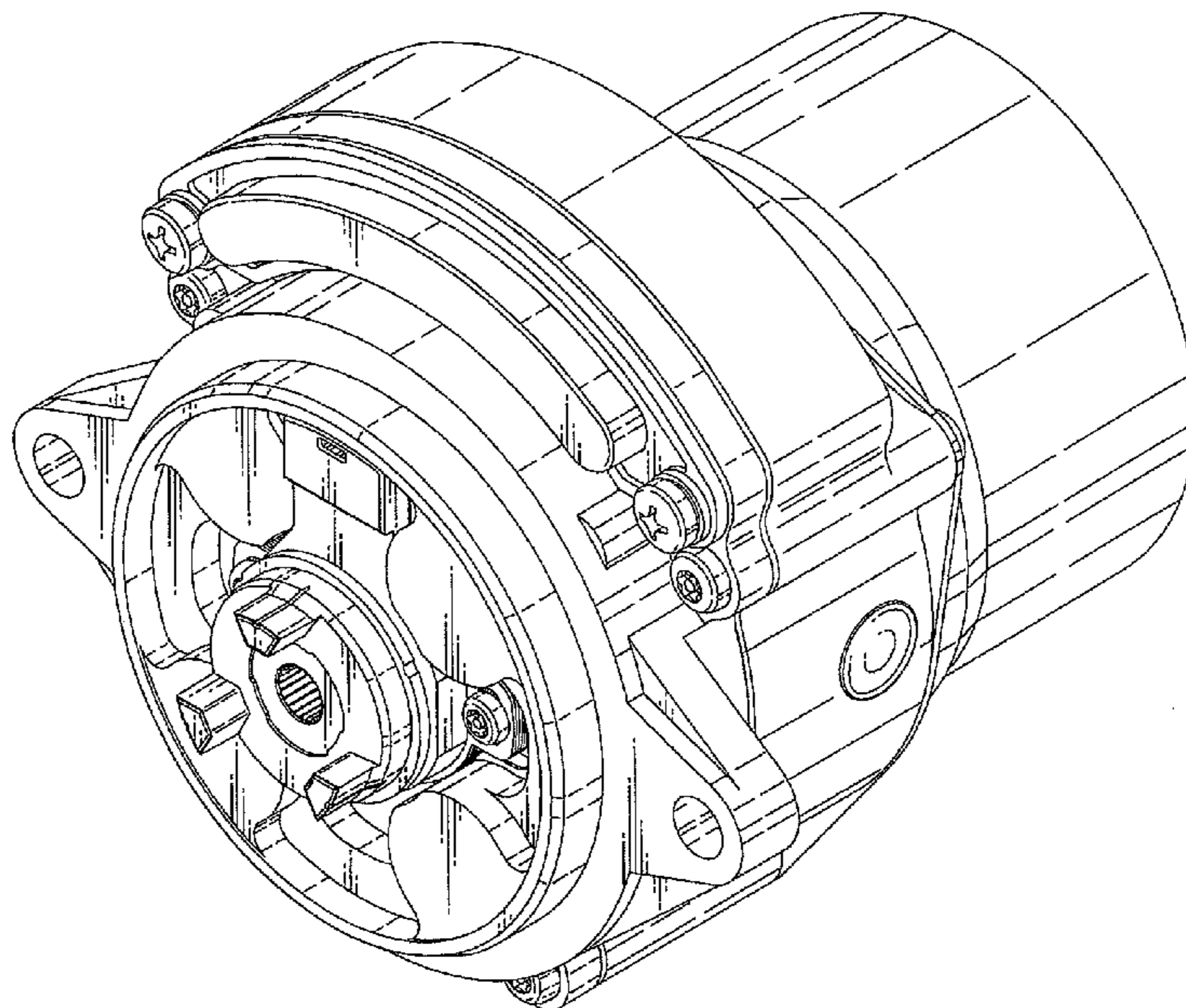

Fig. 1

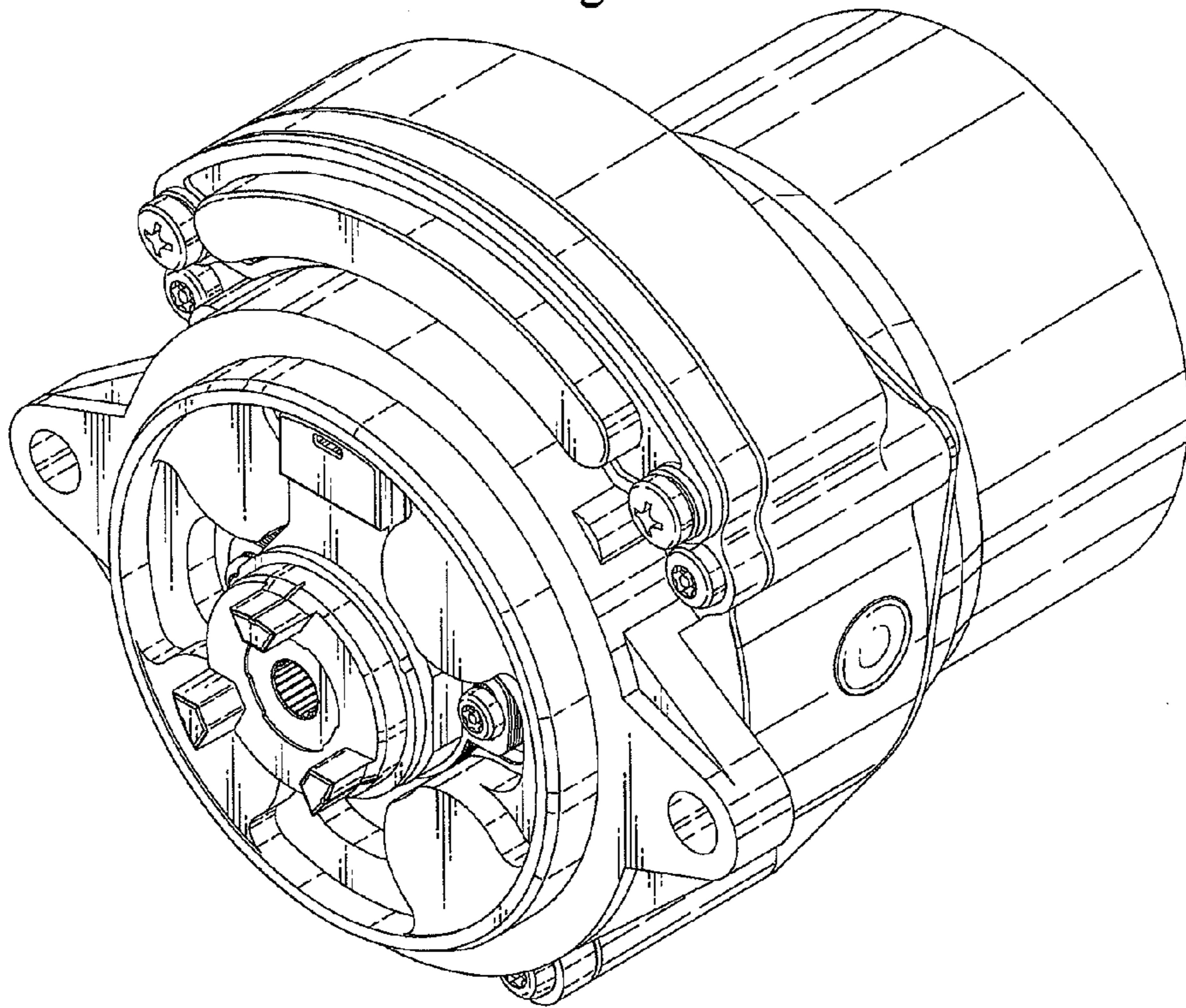
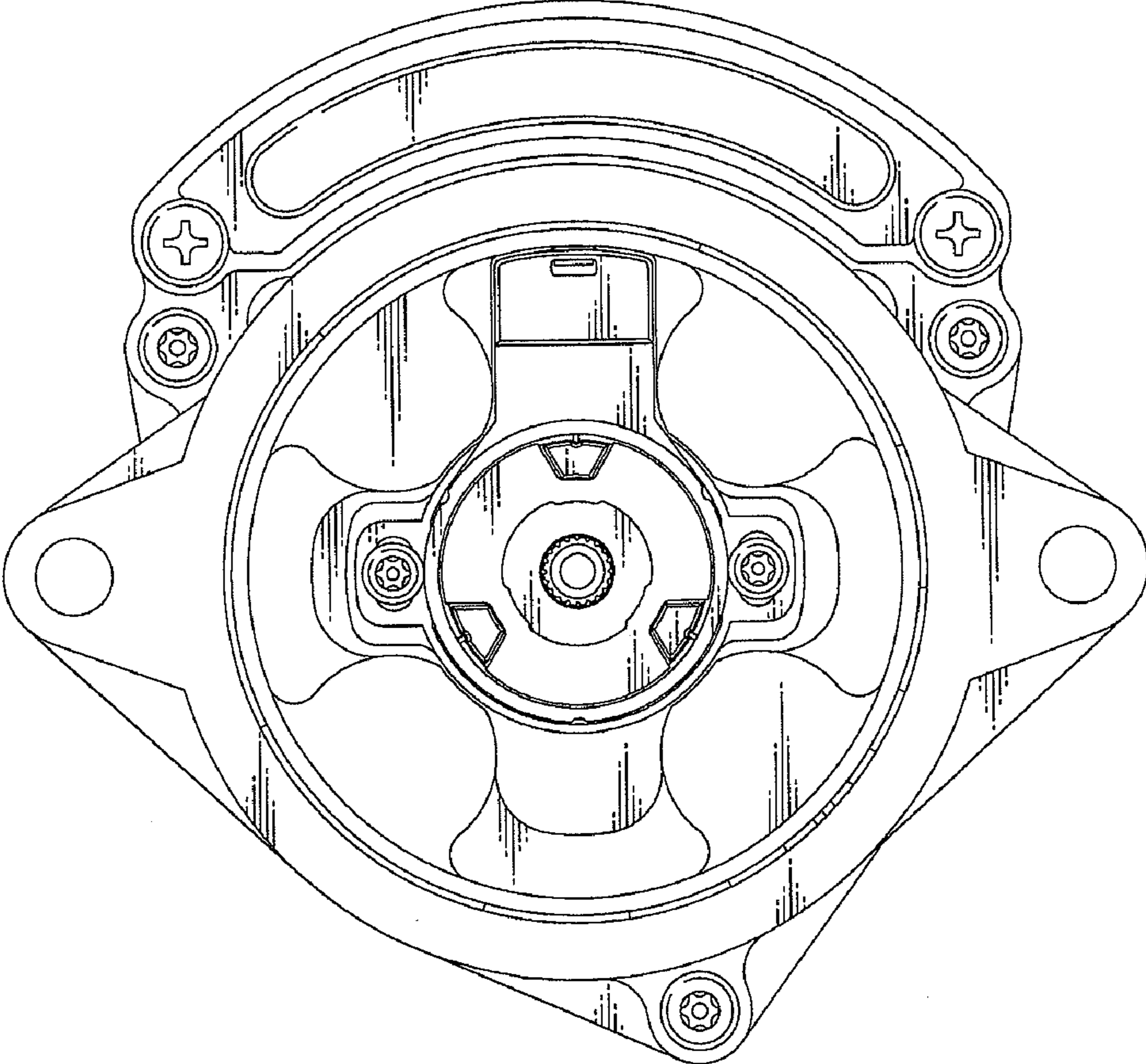

Fig. 2



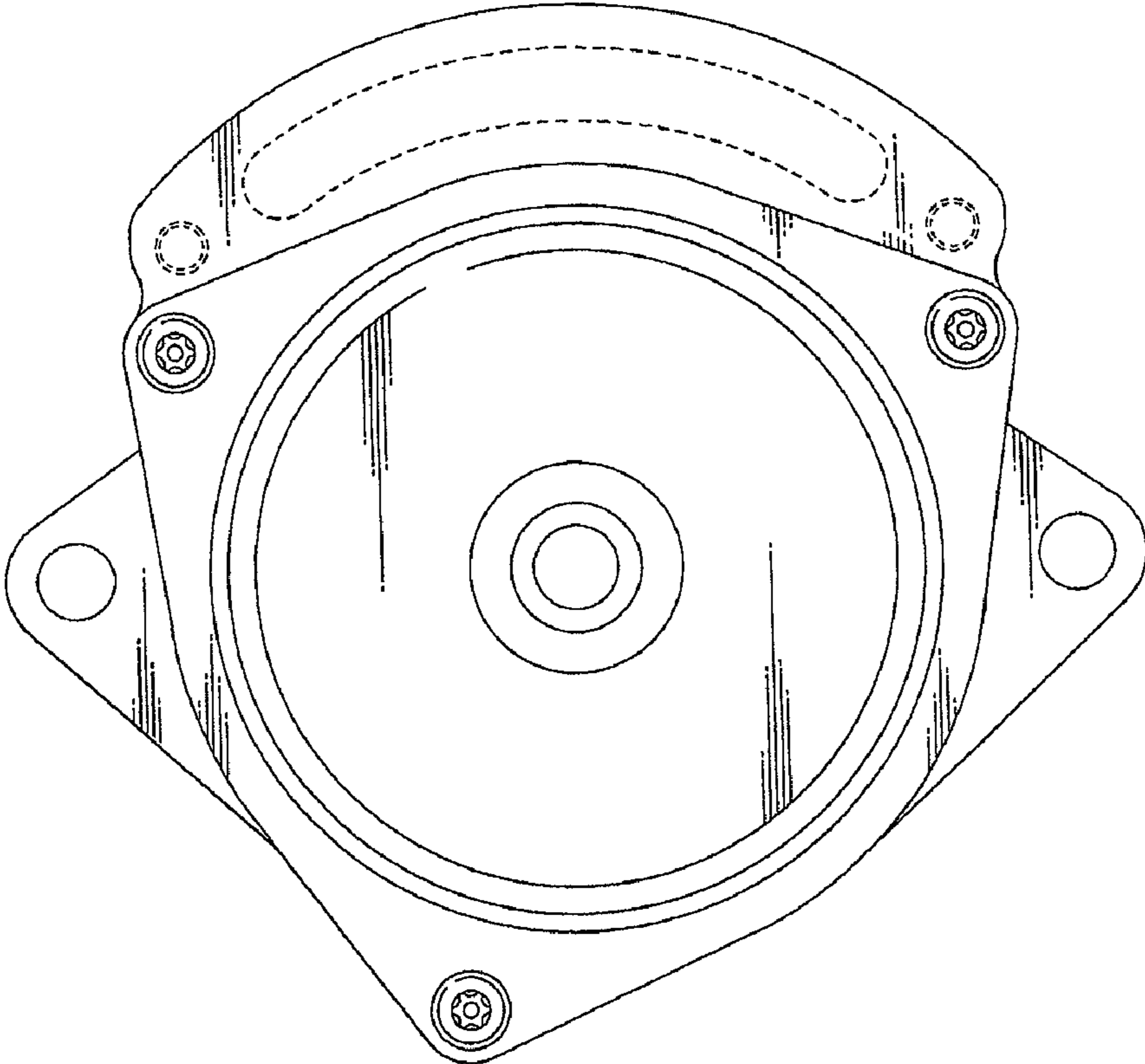

FIG. 3

Fig. 4

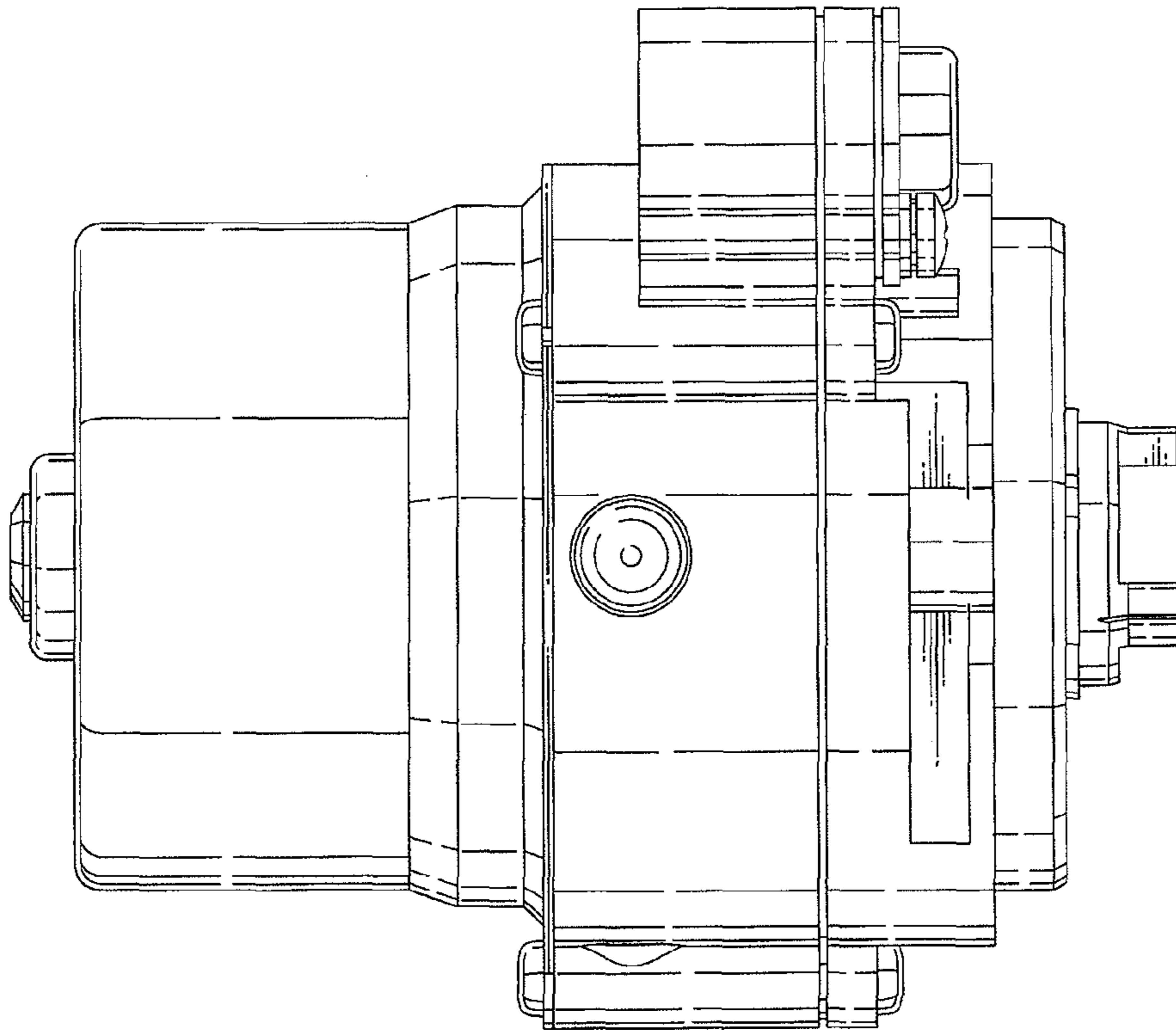

Fig. 5

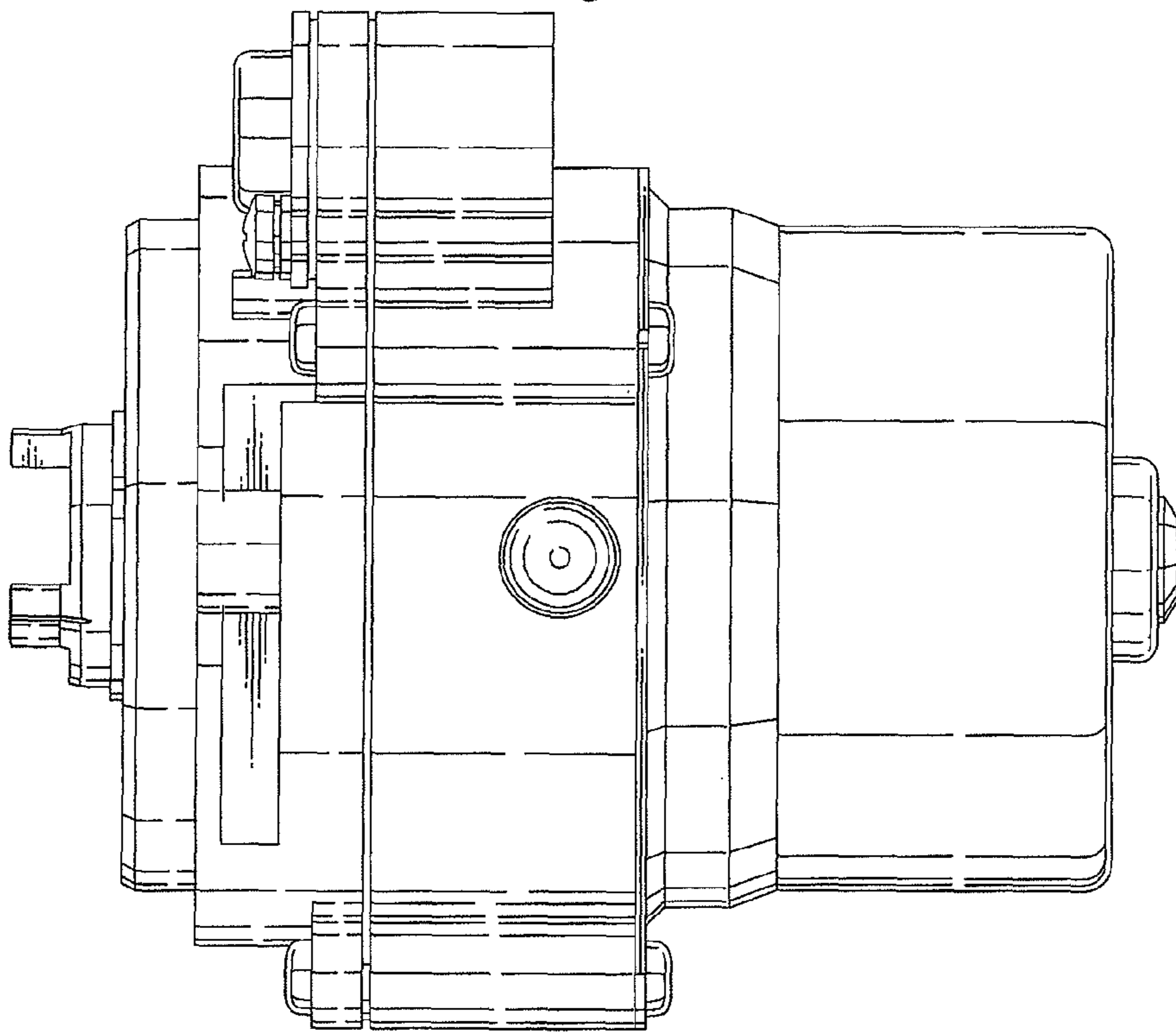

Fig. 6

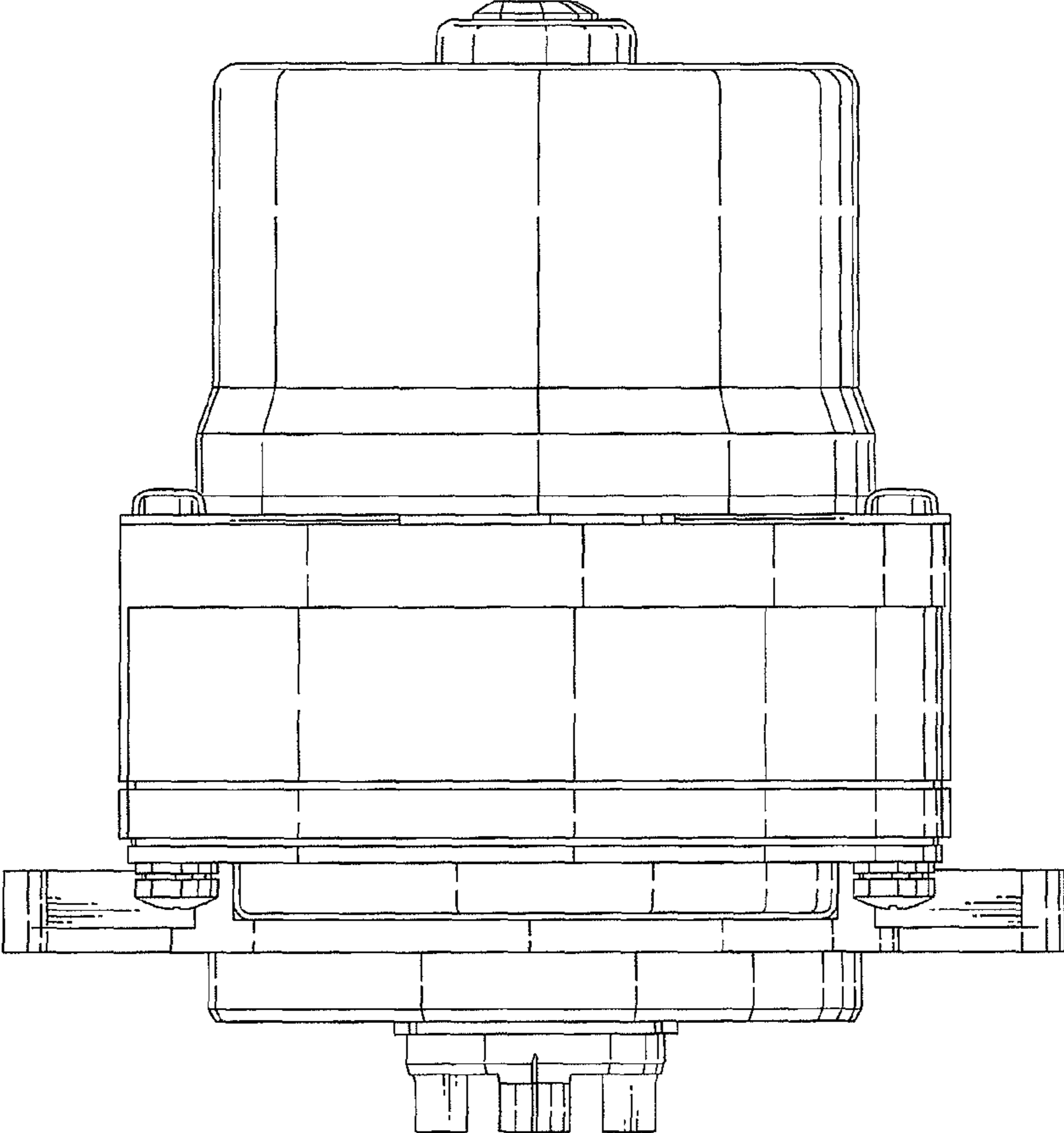
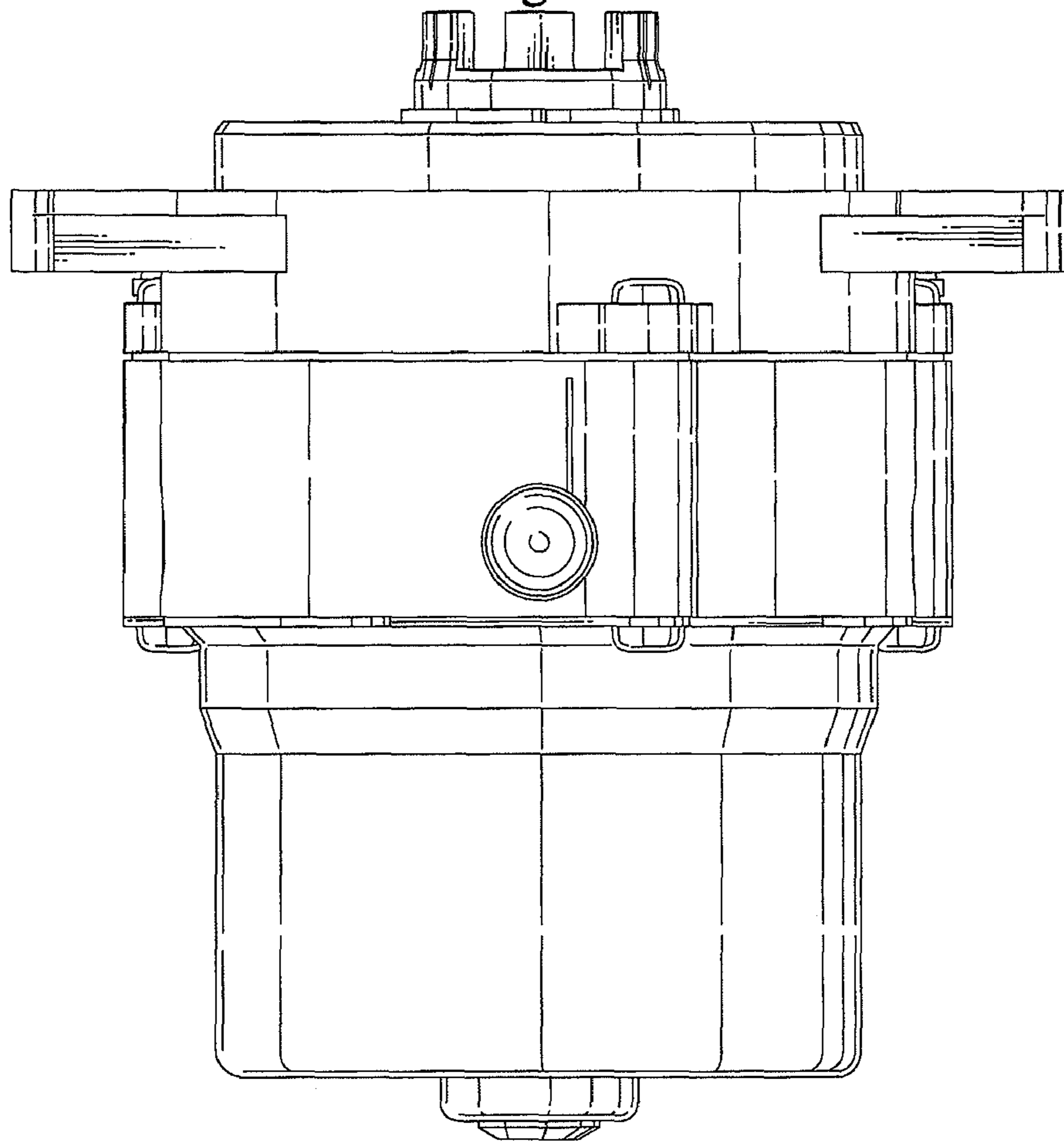

Fig. 7



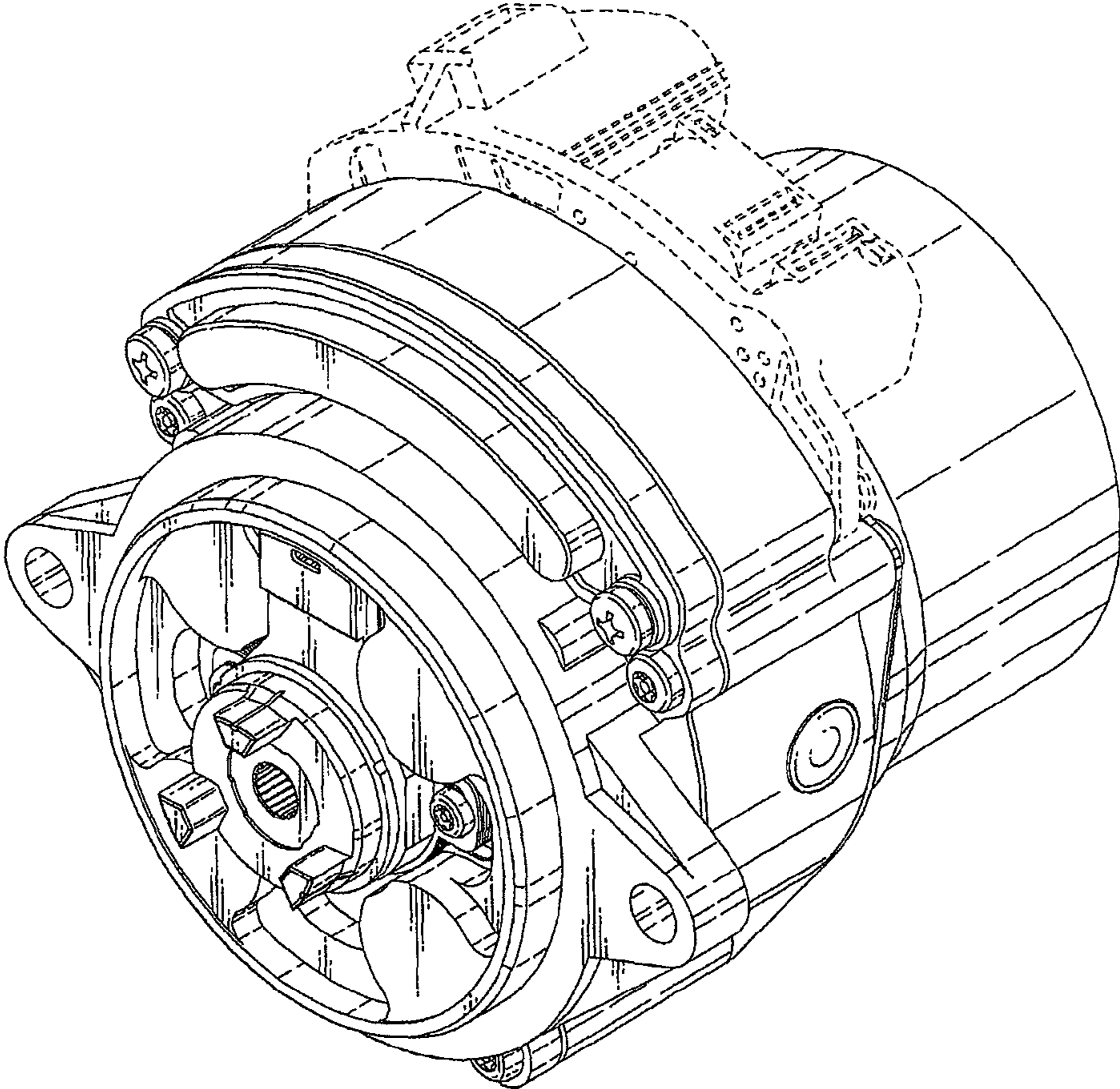

FIG. 8

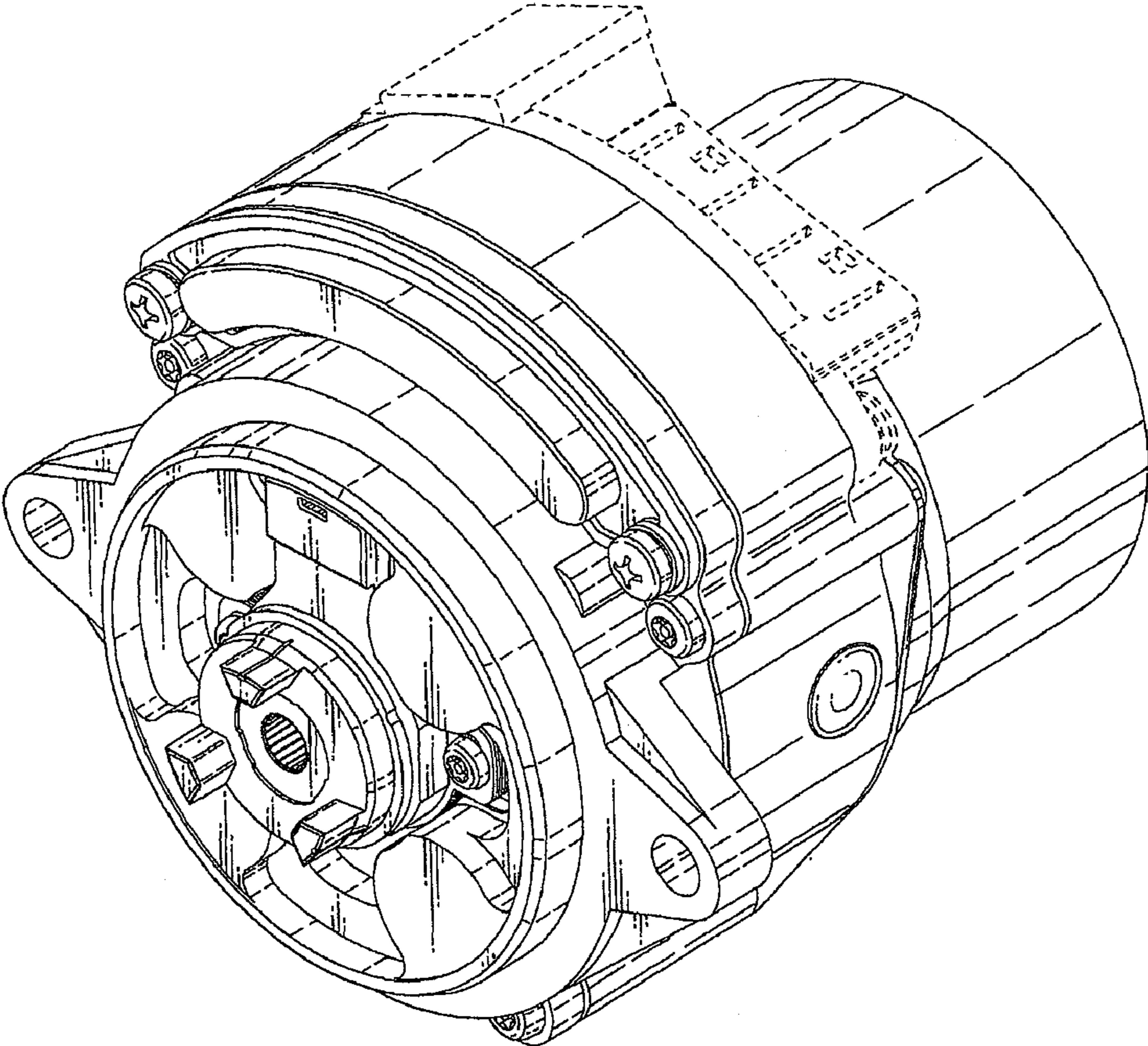

FIG. 9

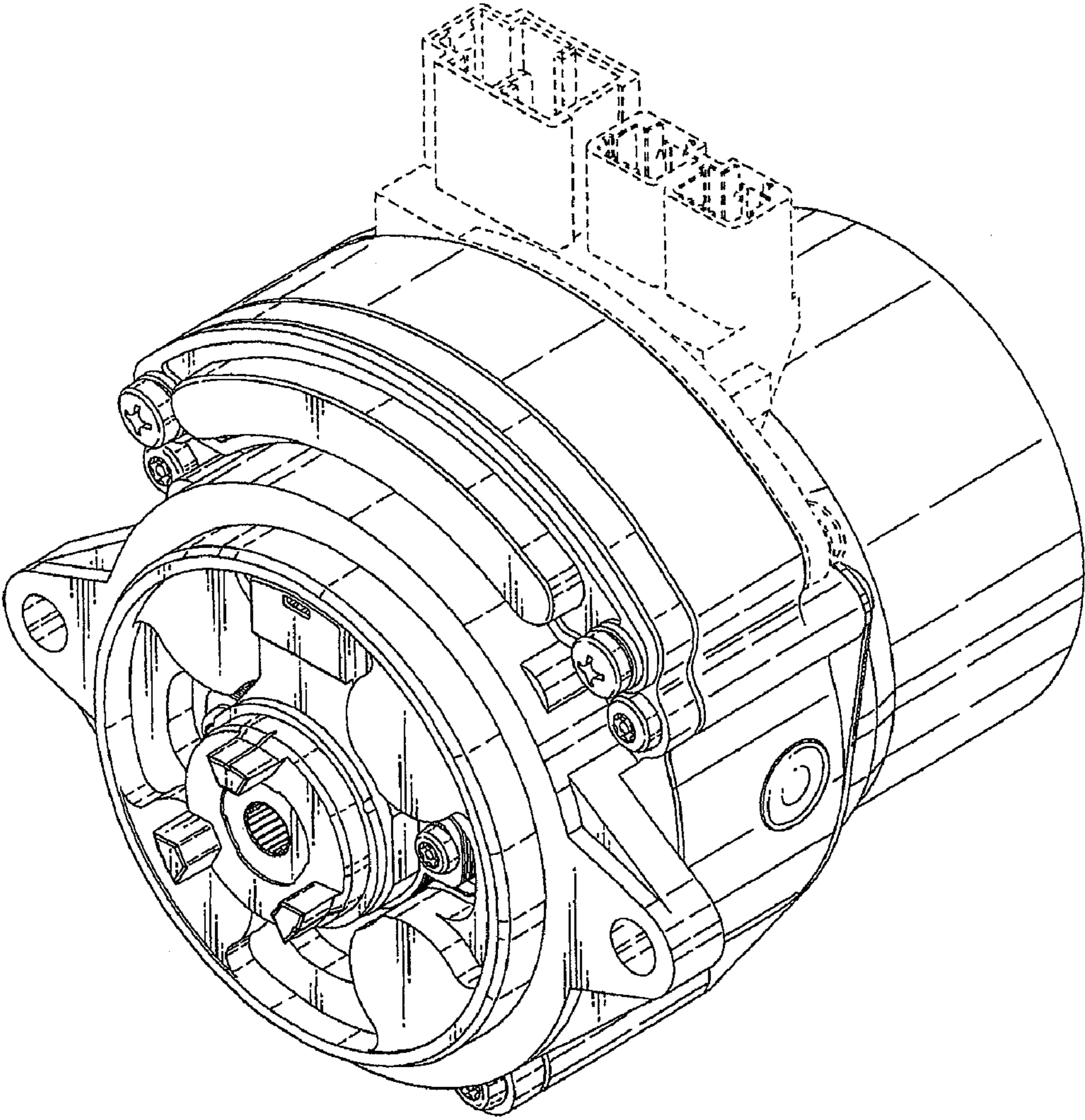

FIG. 10

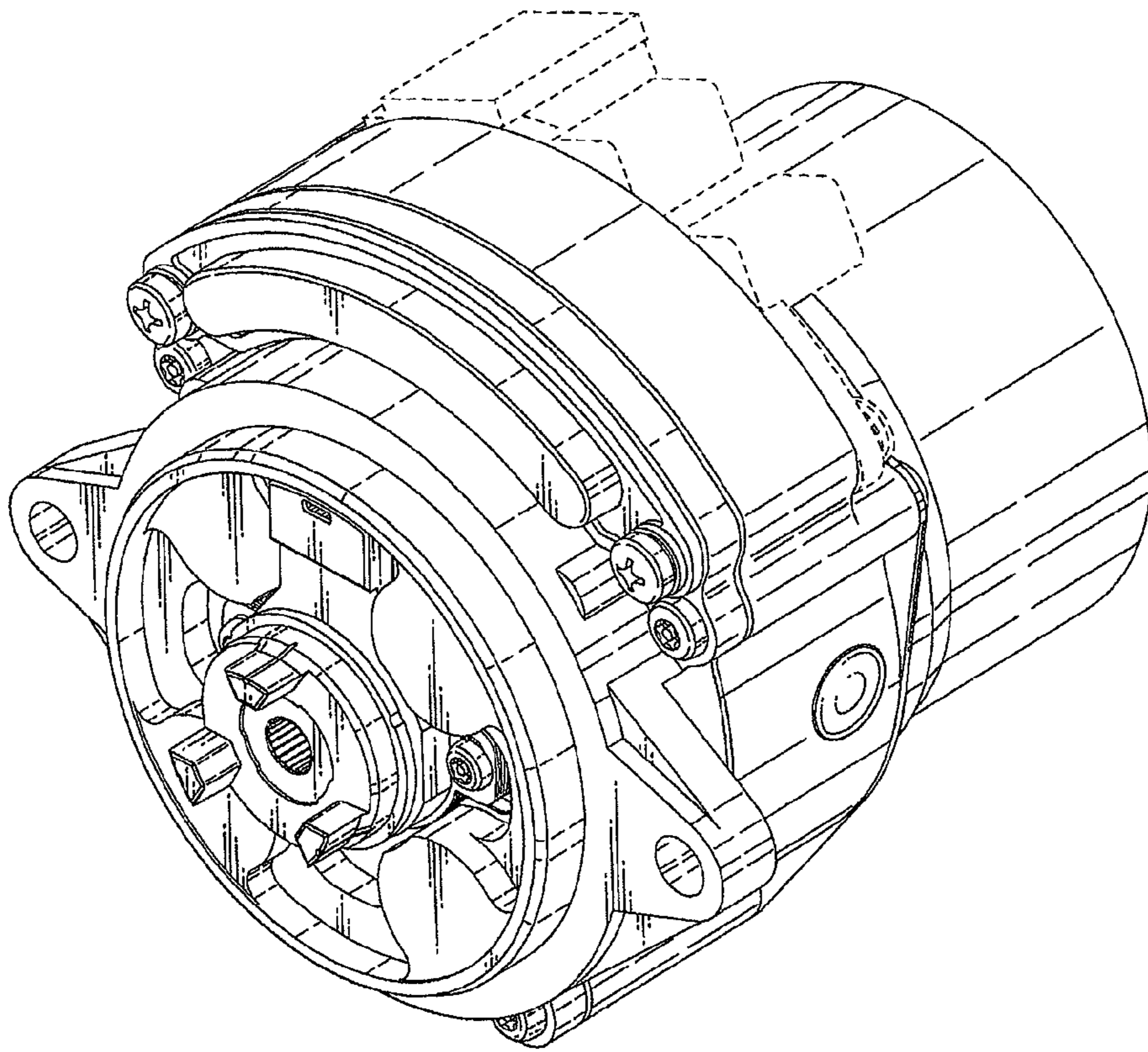

FIG. 11

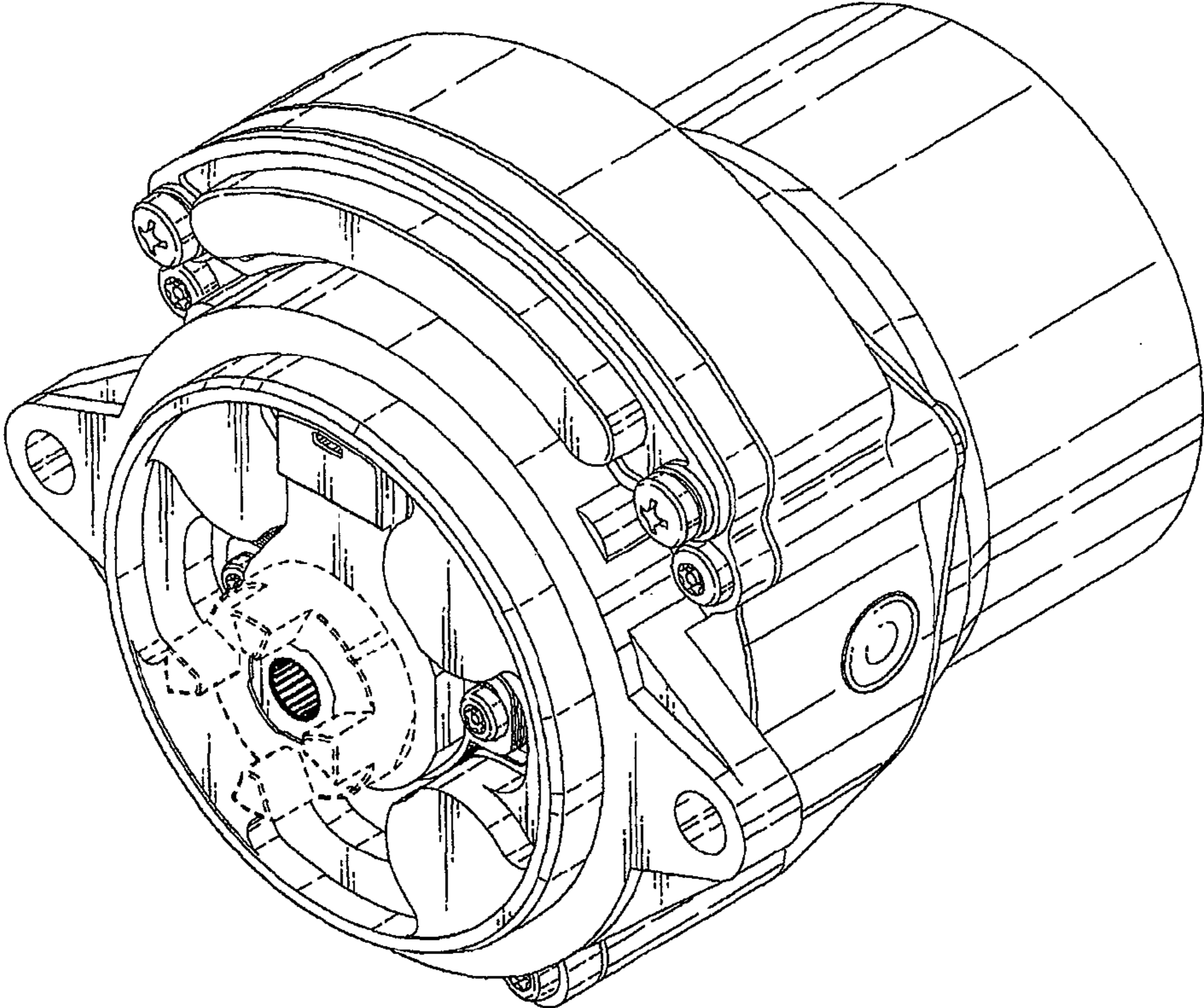

FIG. 12

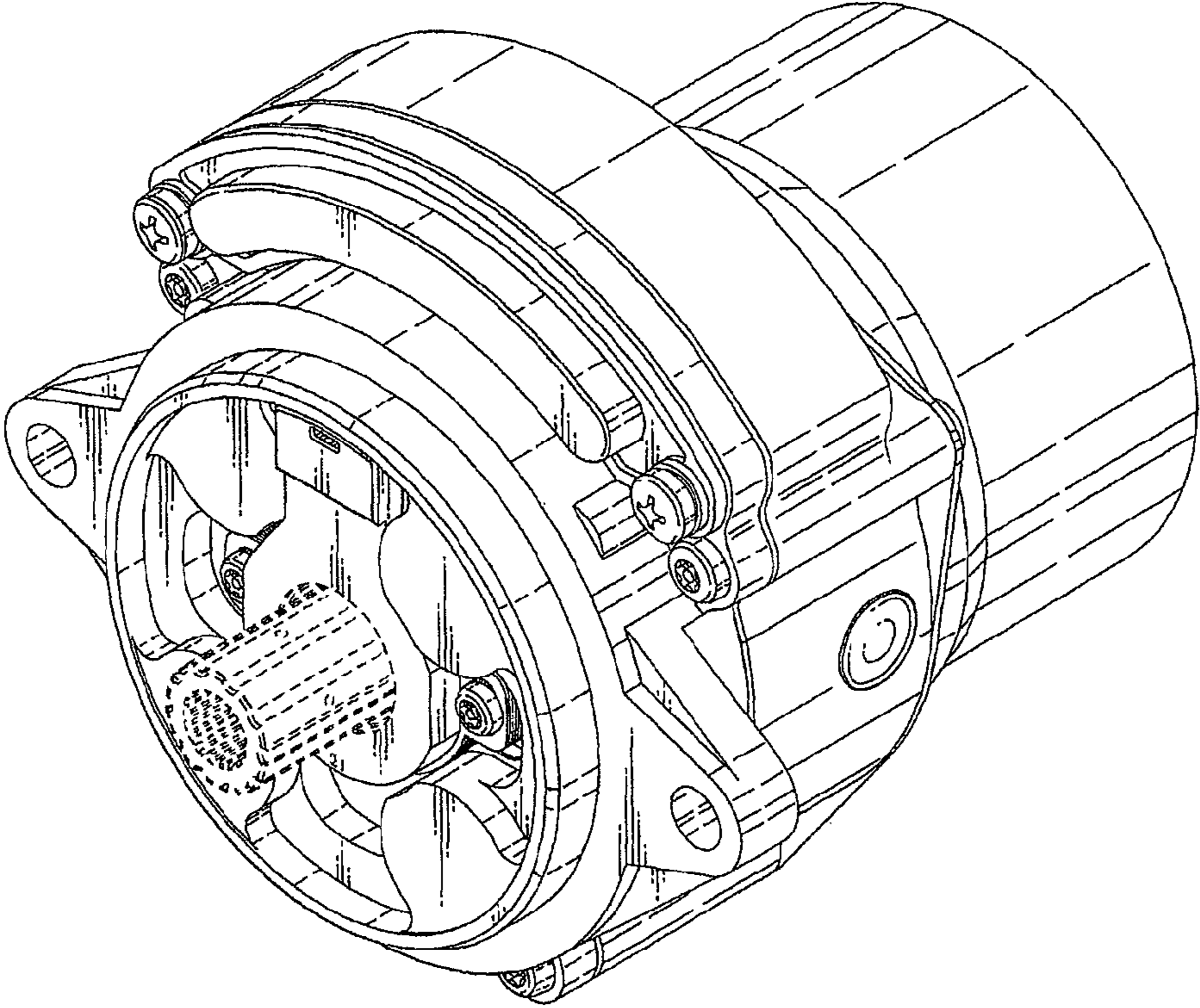

FIG. 13