



US00D664474S

(12) **United States Design Patent**
Stoschek et al.

(10) **Patent No.:** **US D664,474 S**
(45) **Date of Patent:** **** Jul. 31, 2012**

(54) **AUTOMOBILE BODY**

(75) Inventors: **Michael Stoschek**, Coburg (DE); **Luca Borgogno**, Andezeno (IT)

(73) Assignee: **Brose Fahrzeugteile GmbH & Co. KG**, Coburg, Coburg (DE)

(**) Term: **14 Years**

(21) Appl. No.: **29/373,154**

(22) Filed: **Mar. 7, 2011**
(Under 37 CFR 1.47)

(30) **Foreign Application Priority Data**

Feb. 21, 2011	(EM)	001824137-0001
Feb. 21, 2011	(EM)	001824137-0002
Feb. 21, 2011	(EM)	001824137-0003
Feb. 21, 2011	(EM)	001824137-0004
Feb. 21, 2011	(EM)	001824137-0005
Feb. 21, 2011	(EM)	001824137-0006
Feb. 21, 2011	(EM)	001824137-0007
Feb. 23, 2011	(EM)	001825613-0001
Feb. 23, 2011	(EM)	001825613-0002
Feb. 23, 2011	(EM)	001825613-0002

(51) **LOC (9) Cl.** **12-08**
(52) **U.S. Cl.** **D12/92**
(58) **Field of Classification Search** D12/86,
D12/90-92, 88; D21/431, 433, 434; 296/181.1,
296/181.5
See application file for complete search history.

(56) **References Cited**

U.S. PATENT DOCUMENTS

D628,124 S	*	11/2010	Stephenson	D12/92
D631,796 S	*	2/2011	Castriota	D12/92
D632,223 S	*	2/2011	Jacob et al.	D12/92
D637,111 S	*	5/2011	Buckley	D12/92

OTHER PUBLICATIONS

3 pictures of Stratos design model, 2004.

JP Office action dated Jan. 10, 2012 for JP Design Application No. 2011-005192 and English language translation, 6 pgs.
JP Office action dated Jan. 10, 2012 for JP Design Application No. 2011-005204 and English language translation, 6 pgs.
JP Office action dated Jan. 10, 2012 for JP Design Application No. 2011-005205 and English language translation, 6 pgs.
JP Office action dated Jan. 10, 2012 for JP Design Application No. 2011-005206 and English language translation, 6 pgs.
Japanese online article cited in Japanese Office actions (cited above) showing car designs; retrieved from the Internet: <<http://response.jp/article/2010/08/17/144060.html>>.
Complaint dated Jul. 12, 2011 filed against the above-identified applicant, regarding the earlier cited Stratos Design Model, filed in an IDS in the subject application on May 17, 2011, 20 pages (English language summary to follow shortly).
Partial English translation and Comparison Enclosure 24 of Copyright Complaint dated Jul. 12, 2011 filed against the above-identified applicant, regarding the earlier cited Stratos Design Model, filed in an IDS in the subject application on May 17, 2011 (Complaint previously submitted in an IDS on Mar. 8, 2012), 5 pgs.
Renderings of 2005 Stratos Model, 1 pg.
Photographs of Lancia Stratos 1970, 1 pg.

* cited by examiner

Primary Examiner — Melody N Brown

(74) *Attorney, Agent, or Firm* — Christie, Parker & Hale, LLP

(57) **CLAIM**

The ornamental design for an automobile body, as shown and described.

DESCRIPTION

FIG. 1 is a front perspective view of an automobile body;
FIG. 2 is a rear perspective view thereof;
FIG. 3 is a top view thereof;
FIG. 4 is a front view thereof;
FIG. 5 is a right side view thereof;
FIG. 6 is a rear view thereof; and,
FIG. 7 is a left side view thereof.
The broken lines presented in the drawings are for illustration only, and do not form a part of the claimed design.

1 Claim, 7 Drawing Sheets

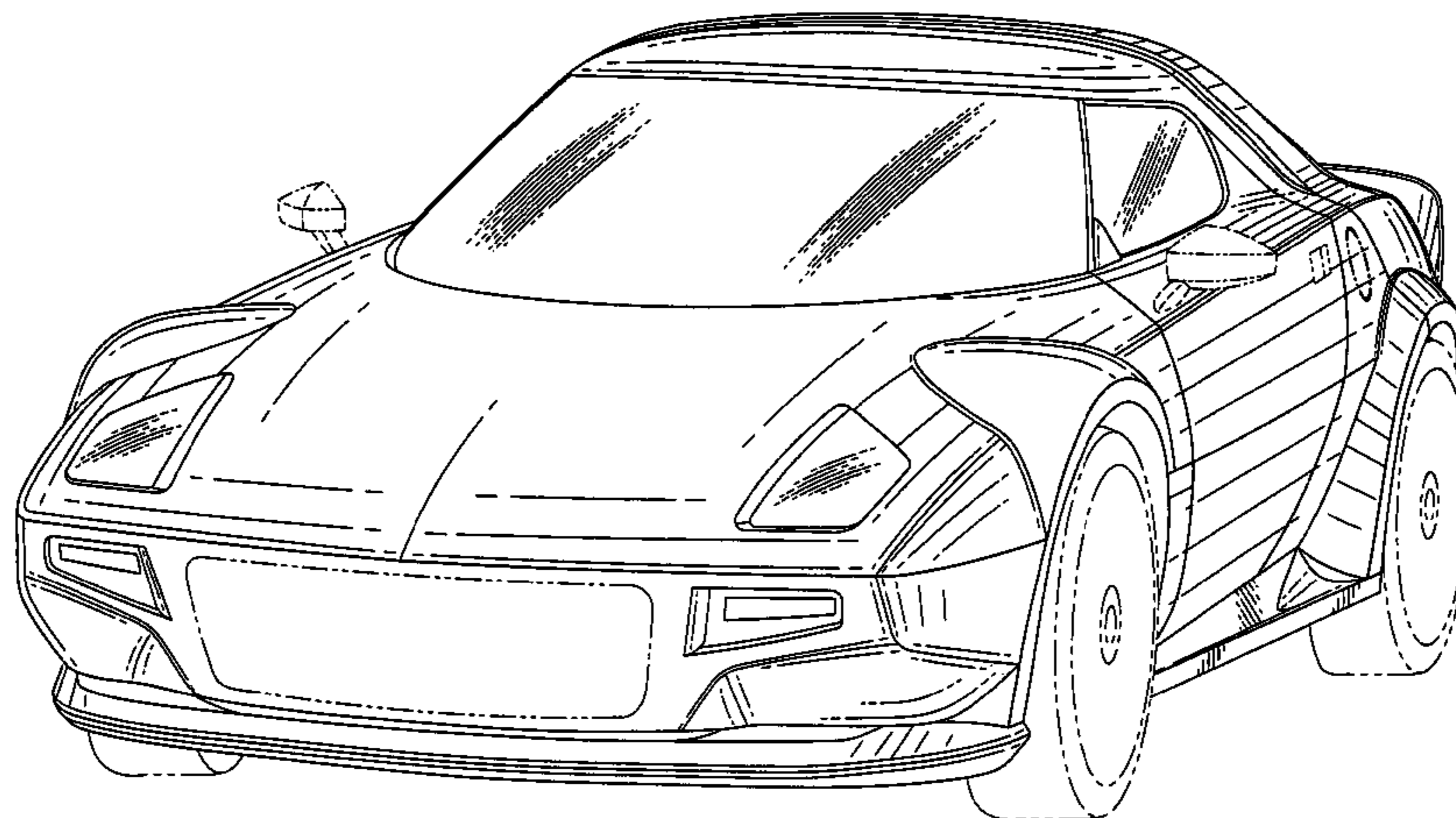

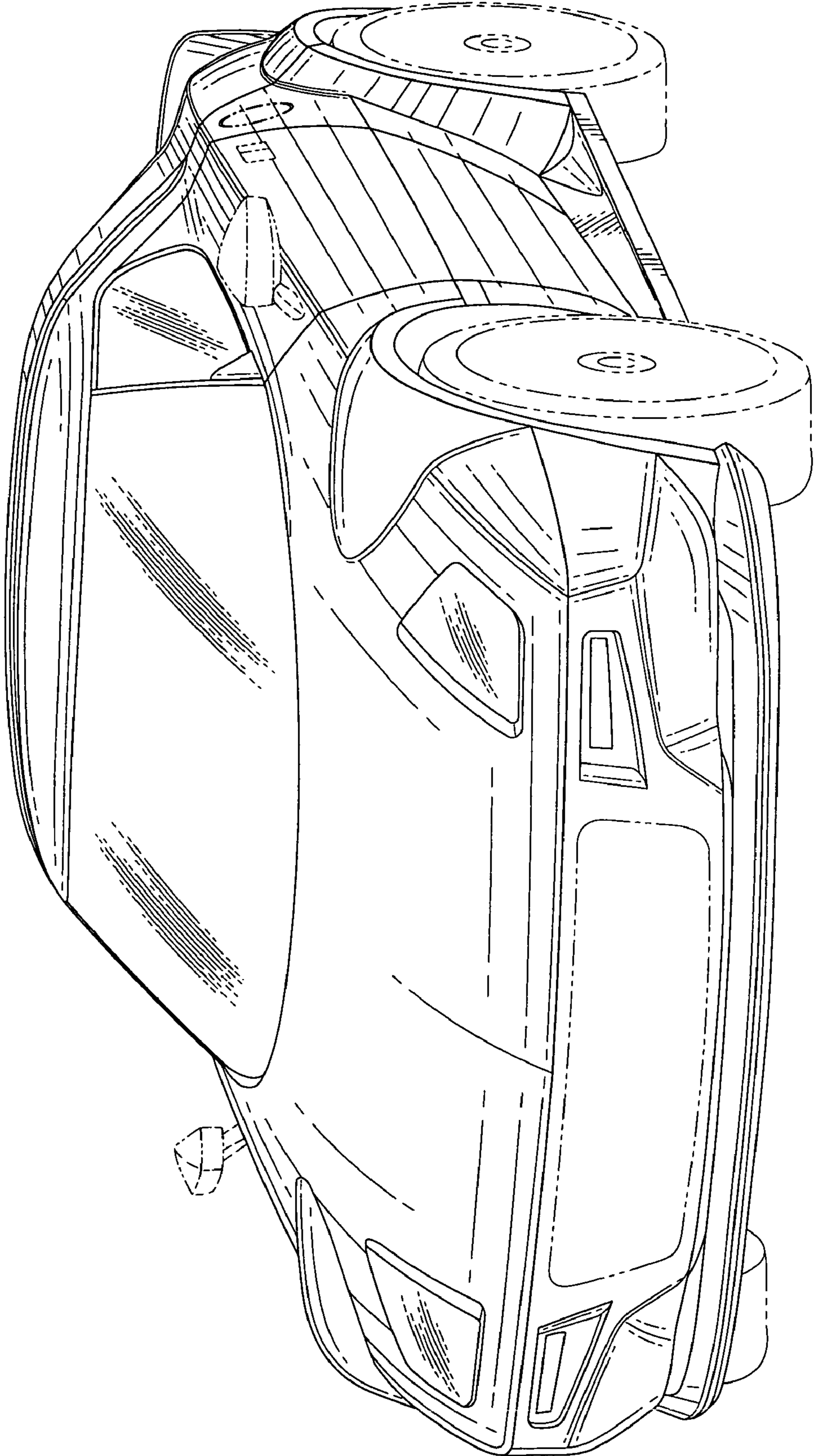

FIG. 1

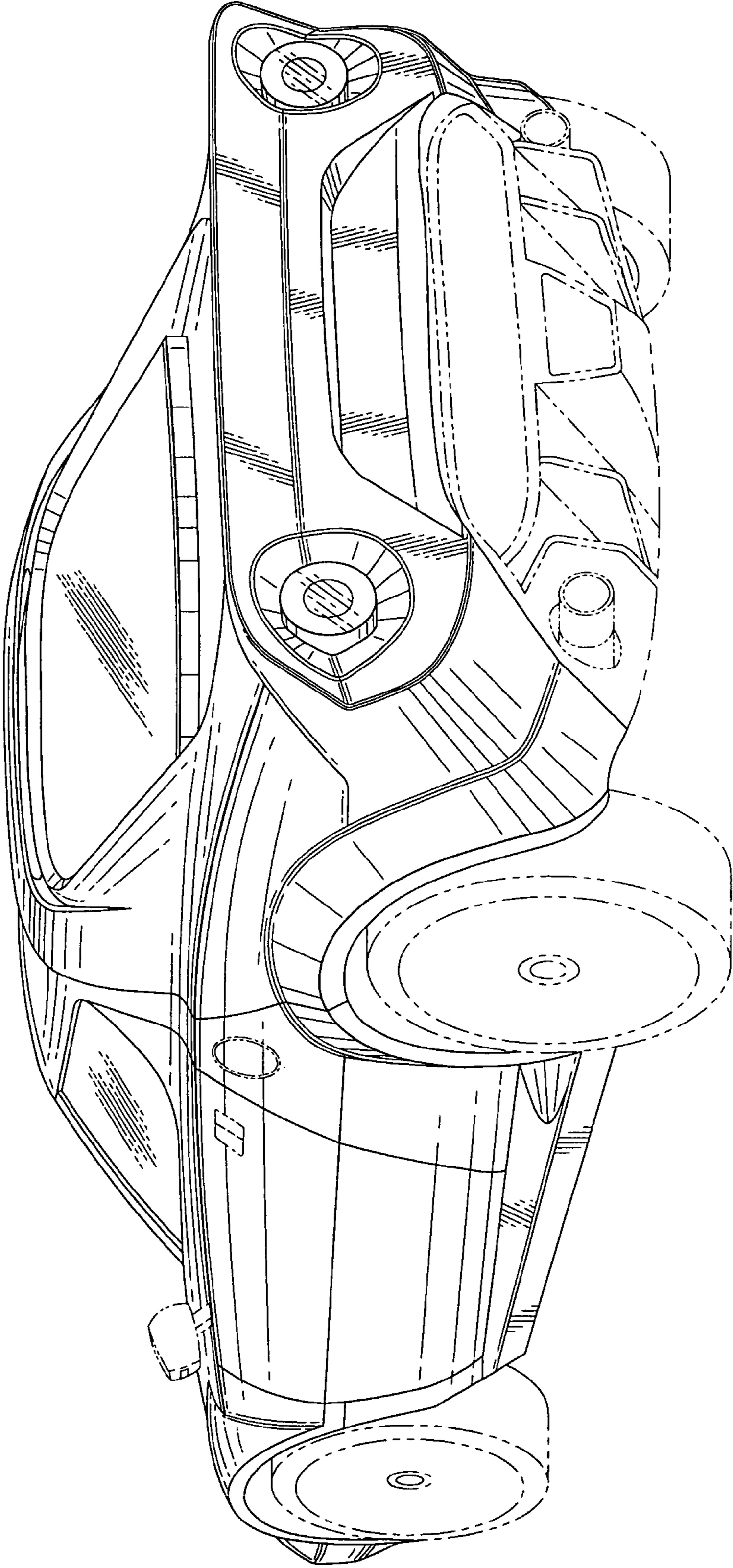

FIG. 2

FIG. 3

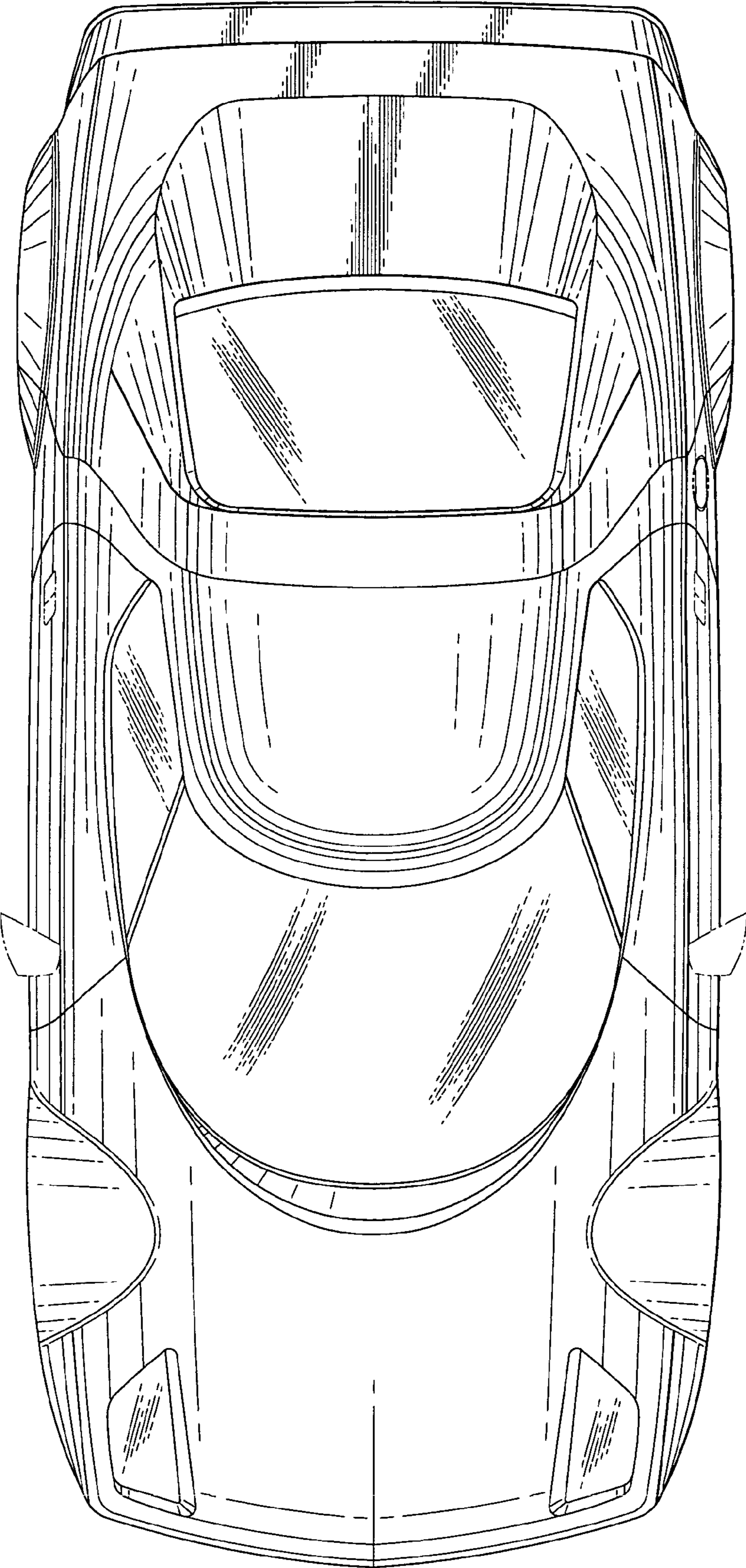

FIG. 4

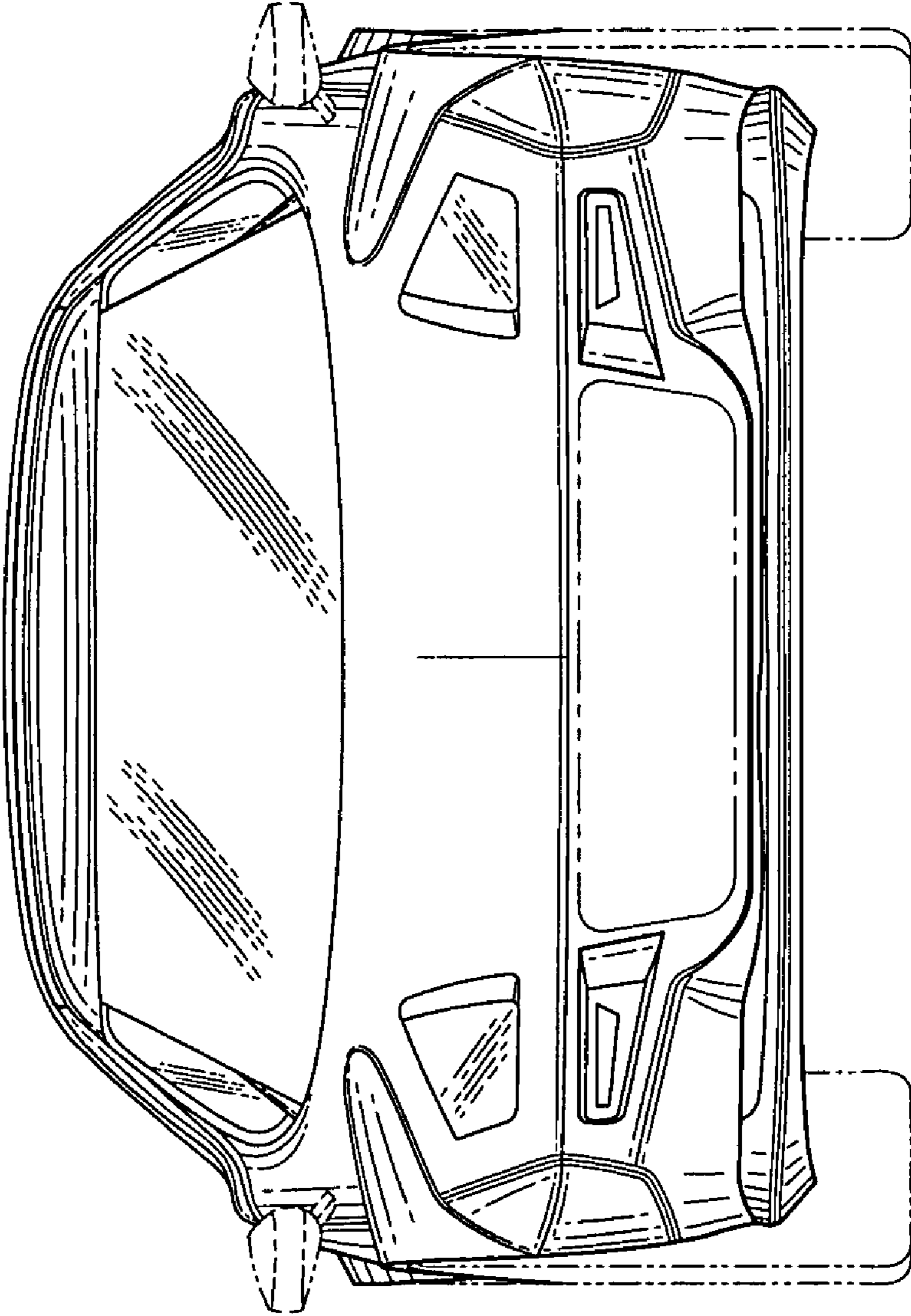

FIG. 5

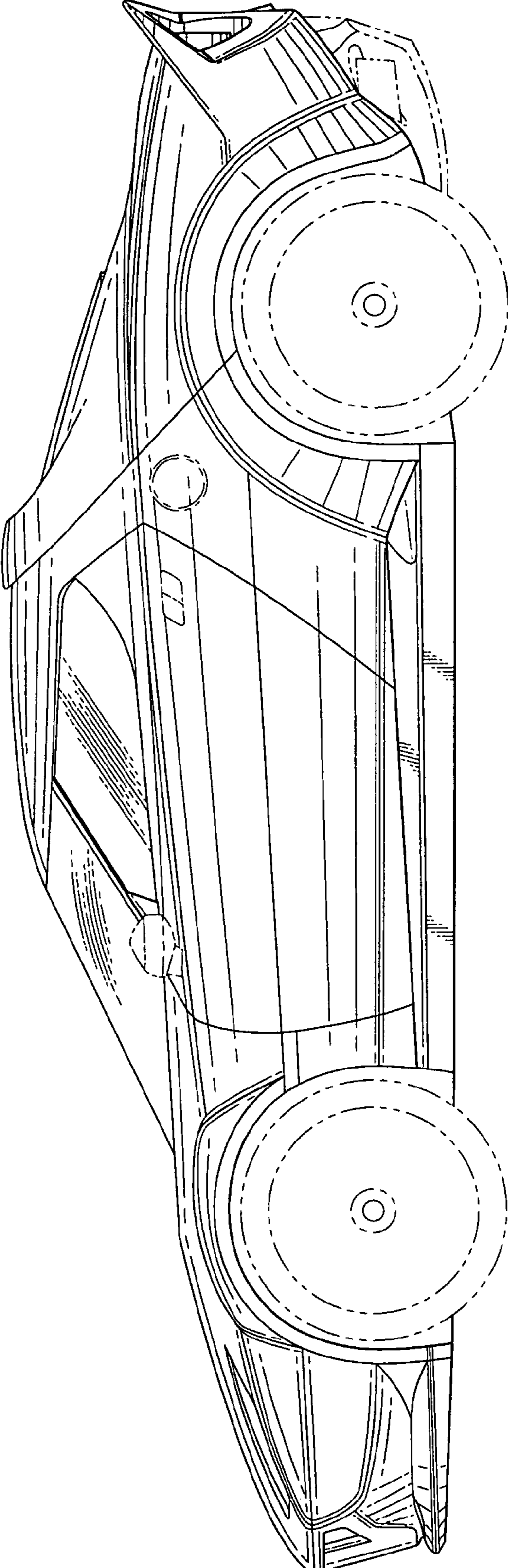

FIG. 6

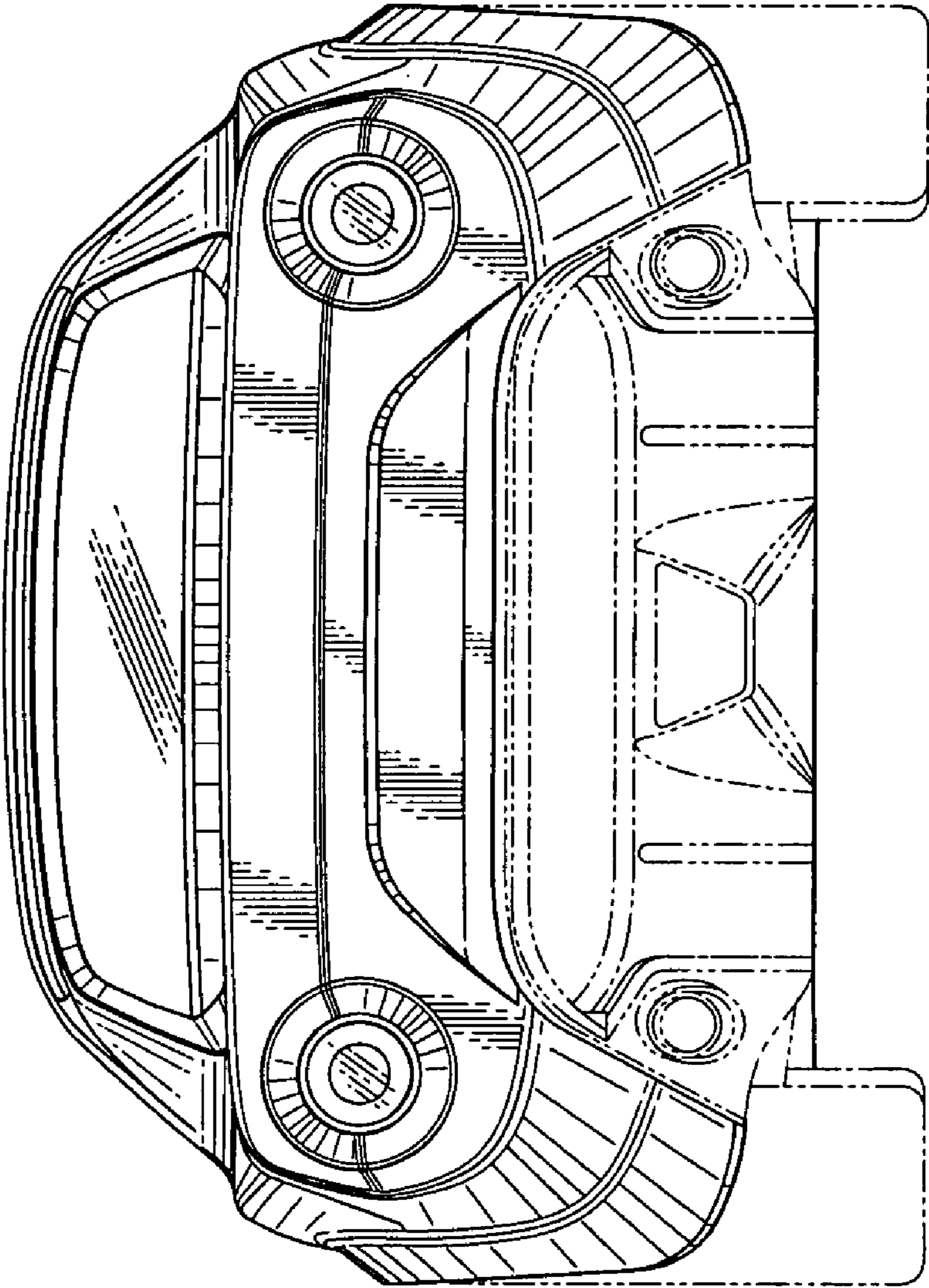

FIG. 7

