



US00D664162S

(12) **United States Design Patent**
Asano et al.

(10) **Patent No.:** **US D664,162 S**
(45) **Date of Patent:** **** Jul. 24, 2012**

(54) **SEWING MACHINE**

(75) Inventors: **Masahide Asano**, Nagoya (JP); **Yosuke Mase**, Nagoya (JP); **Mitsuharu Hattori**, Nagoya (JP)

(73) Assignee: **Brother Industries, Ltd.**, Nagoya (JP)

(**) Term: **14 Years**

(21) Appl. No.: **29/397,238**

(22) Filed: **Jul. 13, 2011**

(30) **Foreign Application Priority Data**

Jan. 14, 2011 (JP) 2011-000675

(51) **LOC (9) Cl.** **15-06**

(52) **U.S. Cl.** **D15/69**

(58) **Field of Classification Search** D15/69-76;
112/63, 255-261, 217.1-219.4, 444, 475.01
See application file for complete search history.

(56) **References Cited**

U.S. PATENT DOCUMENTS

D285,571 S *	9/1986	Eguchi et al.	D15/69
D290,368 S *	6/1987	Eguchi	D15/69
D300,745 S *	4/1989	Baruffa	D15/69
D321,695 S *	11/1991	Kuroki	D15/70
D450,723 S *	11/2001	Iwai et al.	D15/70

D516,589 S *	3/2006	Katsuyama et al.	D15/69
D520,027 S *	5/2006	Kuroki	D15/69
D578,554 S *	10/2008	Inada	D15/70
D579,030 S *	10/2008	Woehrle	D15/70
D580,955 S *	11/2008	Woehrle	D15/70
D620,504 S *	7/2010	Hattori	D15/69
D628,605 S *	12/2010	Mutoh	D15/69
D629,020 S *	12/2010	Hattori	D15/69
D642,206 S *	7/2011	Tseng	D15/70
D644,254 S *	8/2011	Tseng	D15/70
D645,886 S *	9/2011	Hattori	D15/69

* cited by examiner

Primary Examiner — Mitchell Siegel

(74) *Attorney, Agent, or Firm* — Oliff & Berridge, PLC

(57) **CLAIM**

The ornamental design for a sewing machine, as shown and described.

DESCRIPTION

FIG. 1 is a perspective view of a sewing machine;
FIG. 2 is a front view thereof;
FIG. 3 is a top view thereof;
FIG. 4 is a right-side view thereof;
FIG. 5 is a left-side view thereof;
FIG. 6 is a rear view thereof;
FIG. 7 is a bottom view thereof; and,
FIG. 8 is another perspective view thereof.

The broken lines depict environmental subject matter only and form no part of the claimed design.

1 Claim, 7 Drawing Sheets

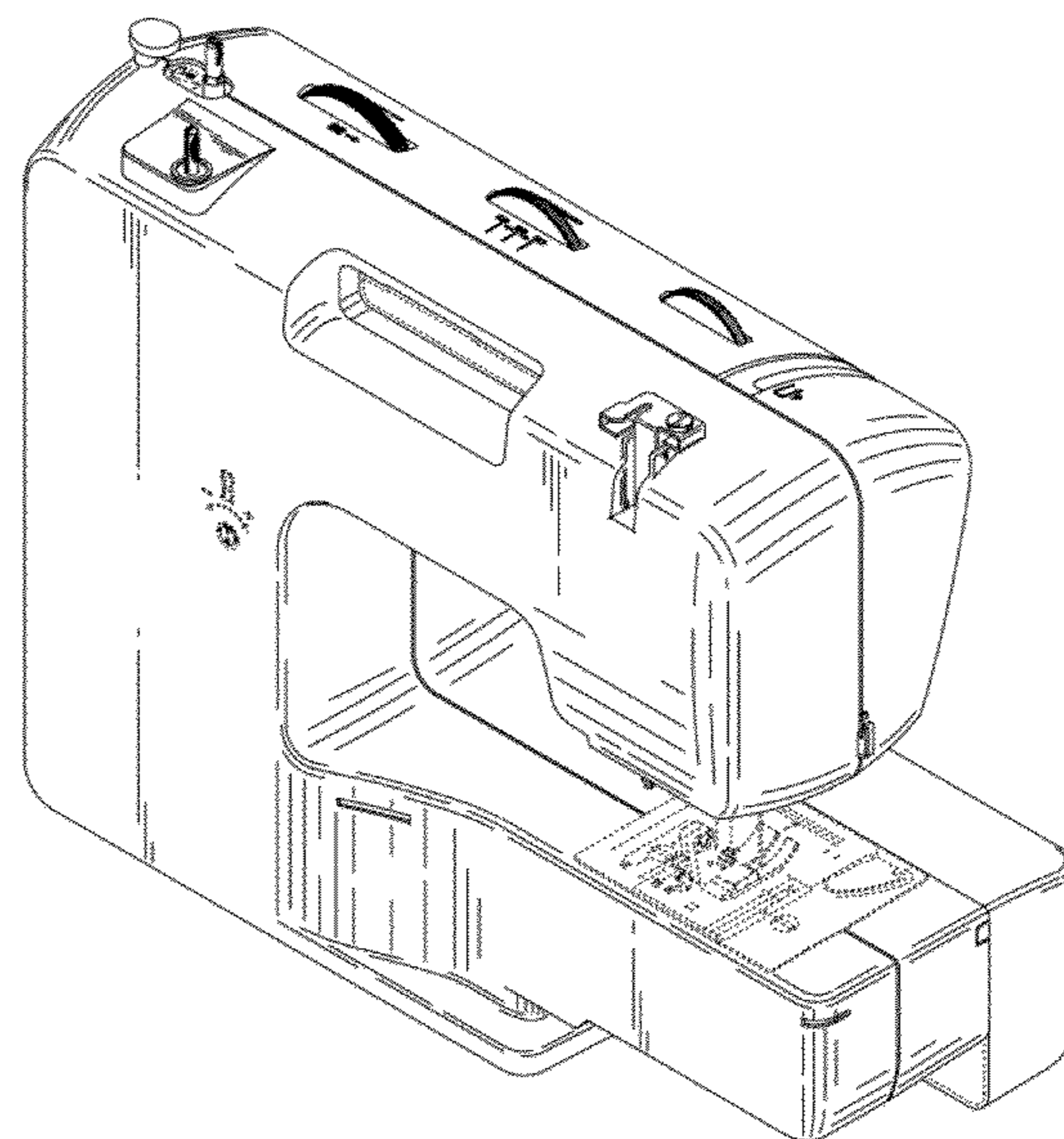
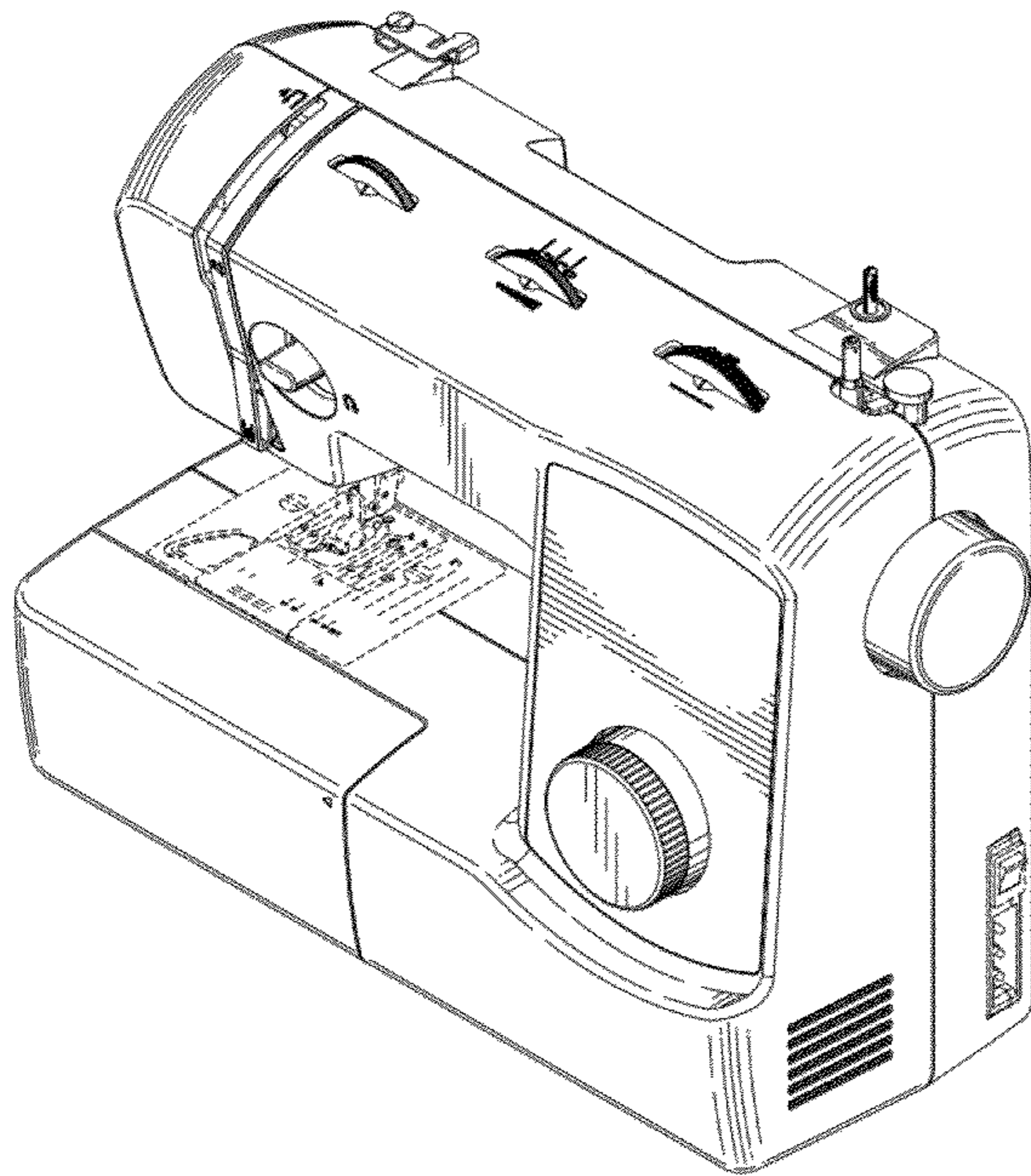

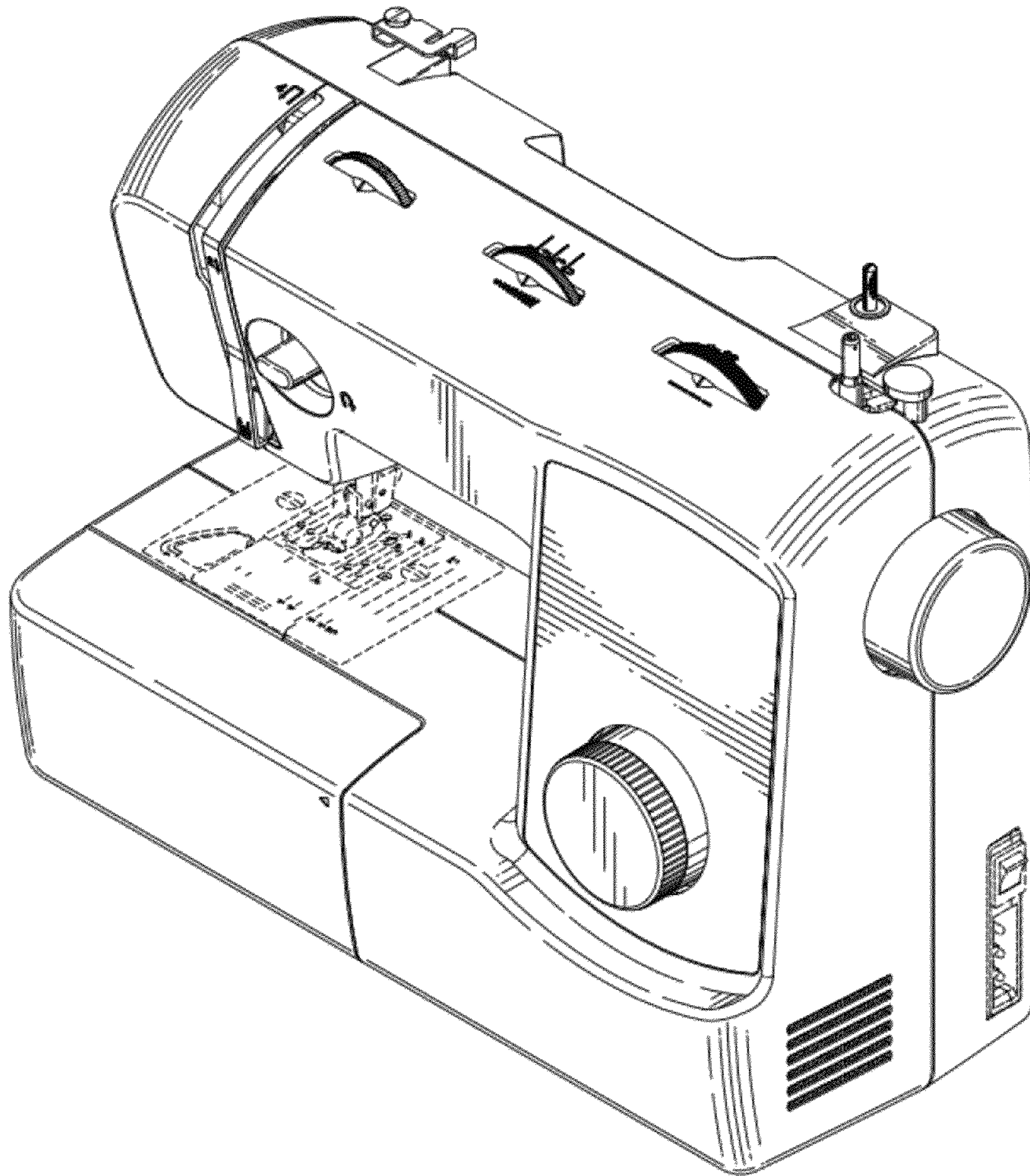

FIG. 1

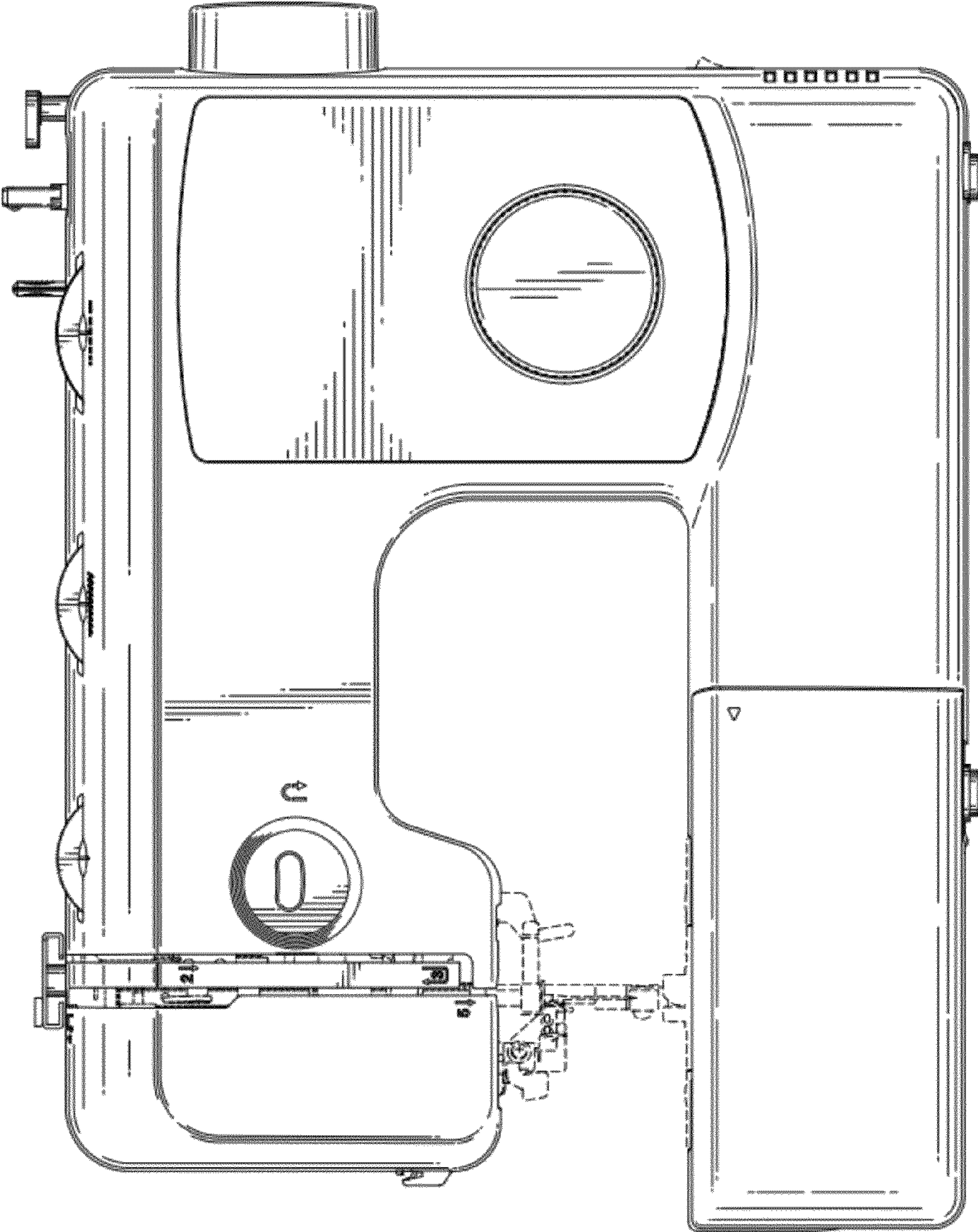

FIG. 2

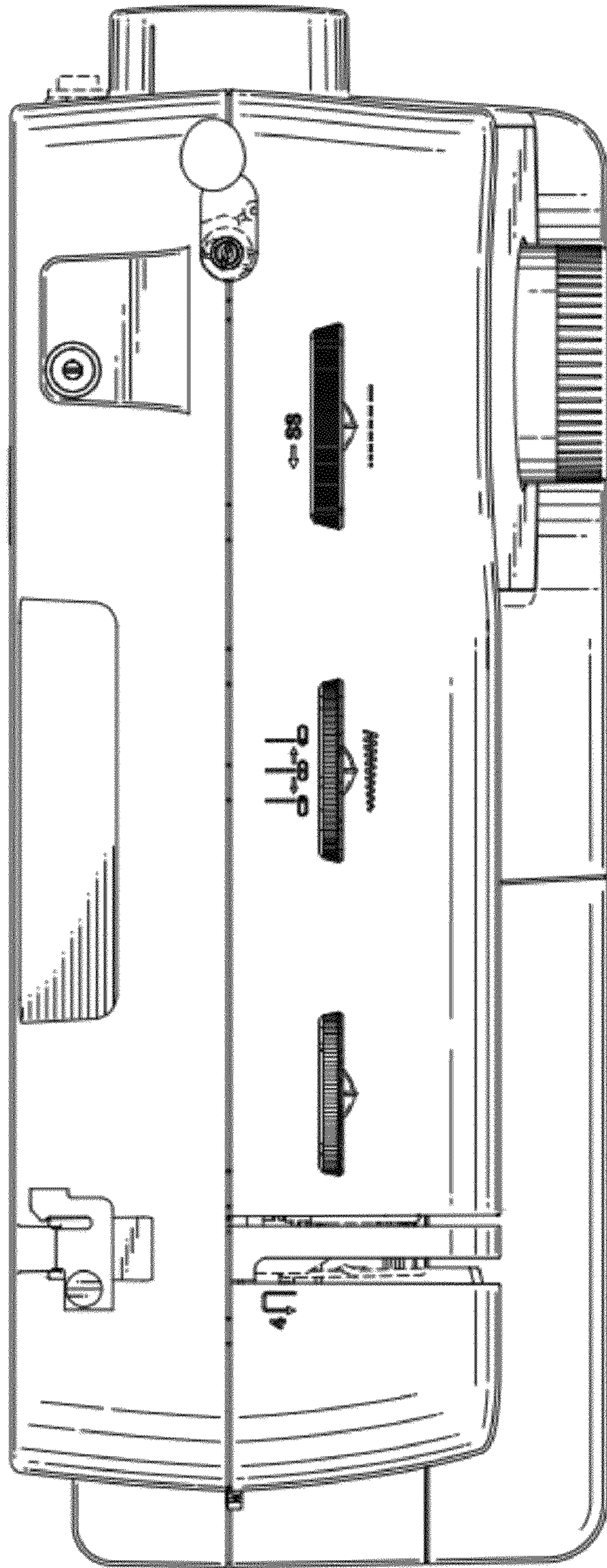

FIG. 3

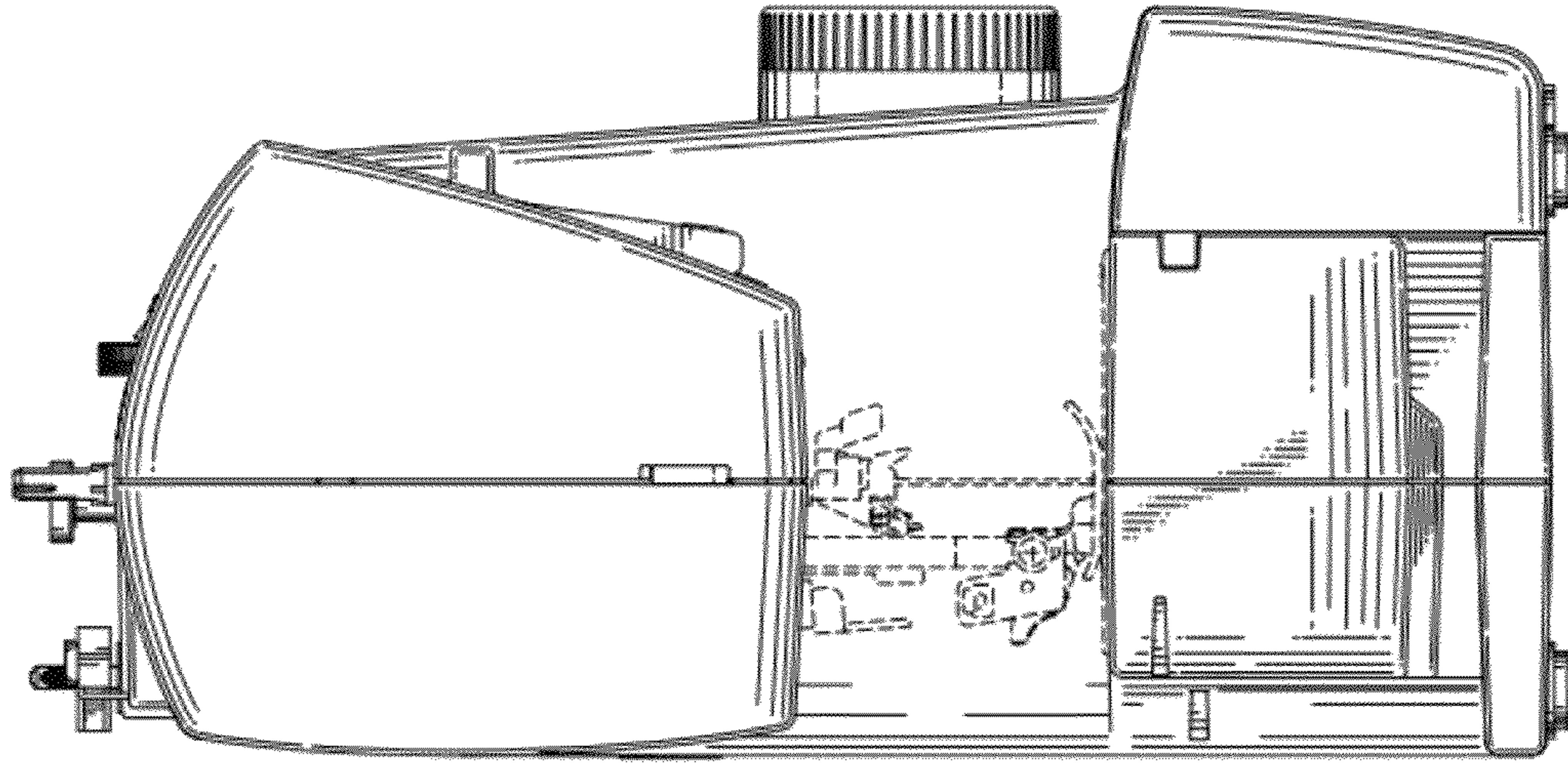

FIG. 5

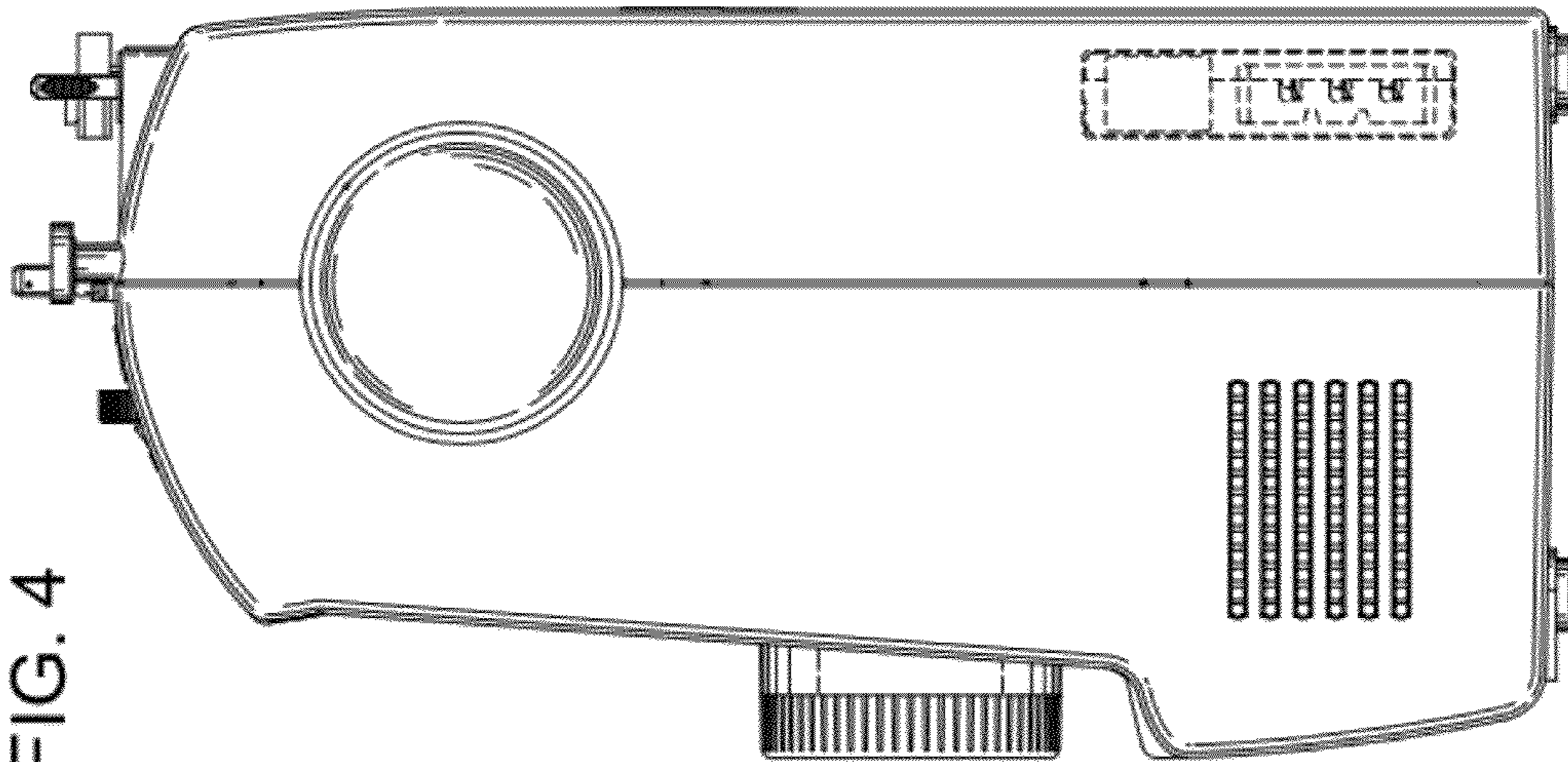

FIG. 4

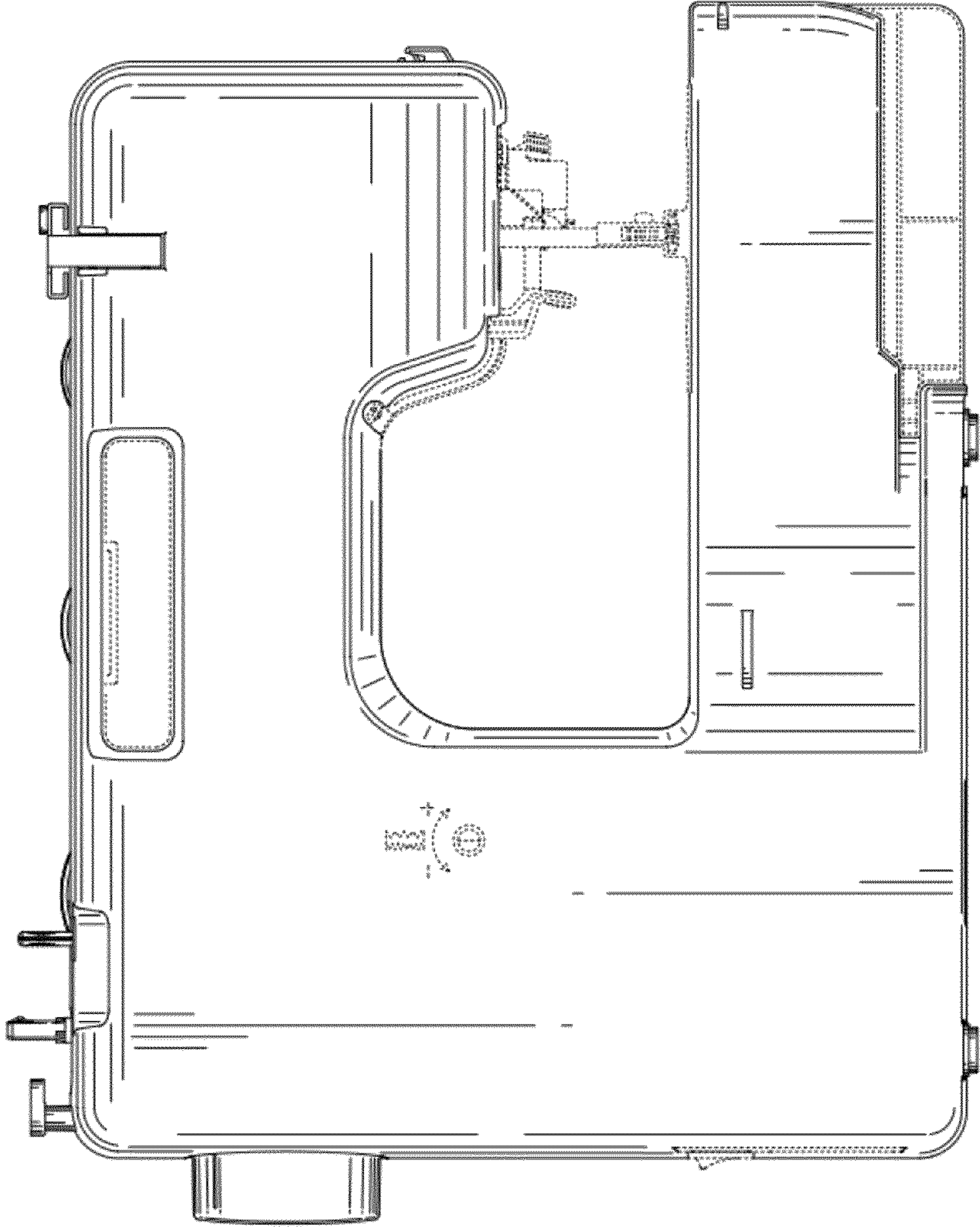

FIG. 6

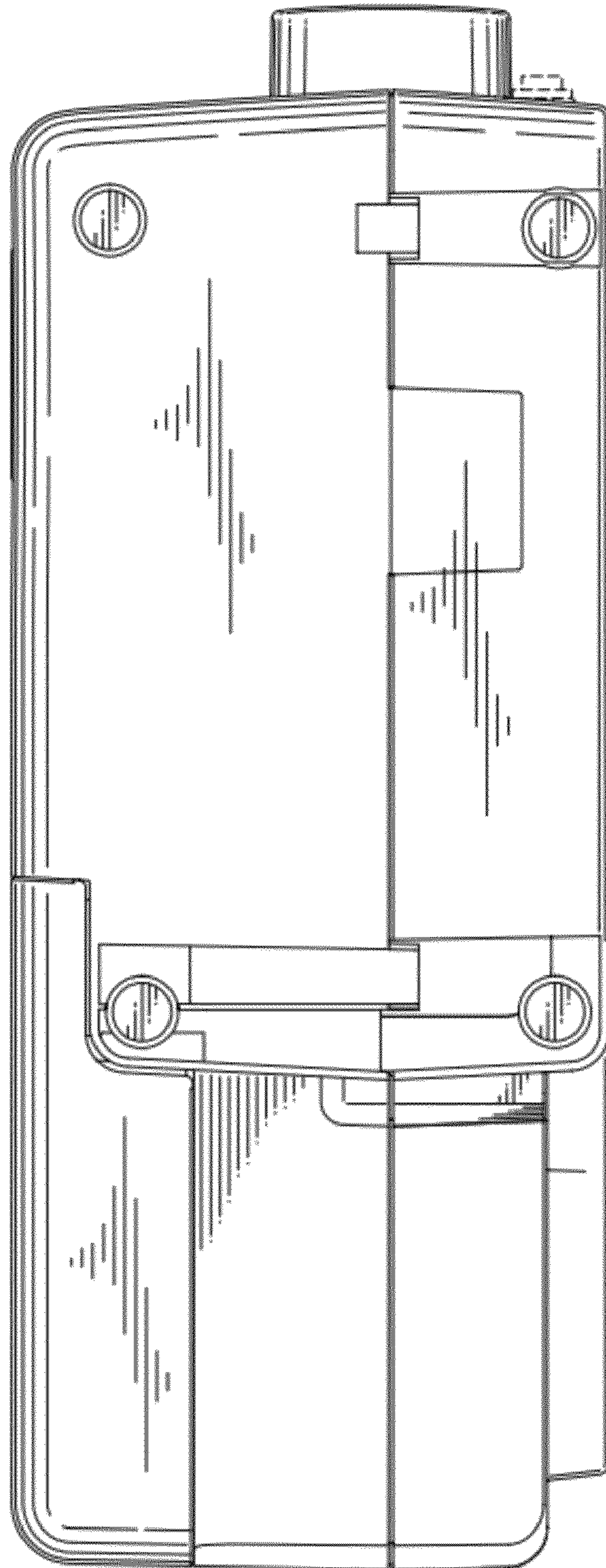

FIG. 7

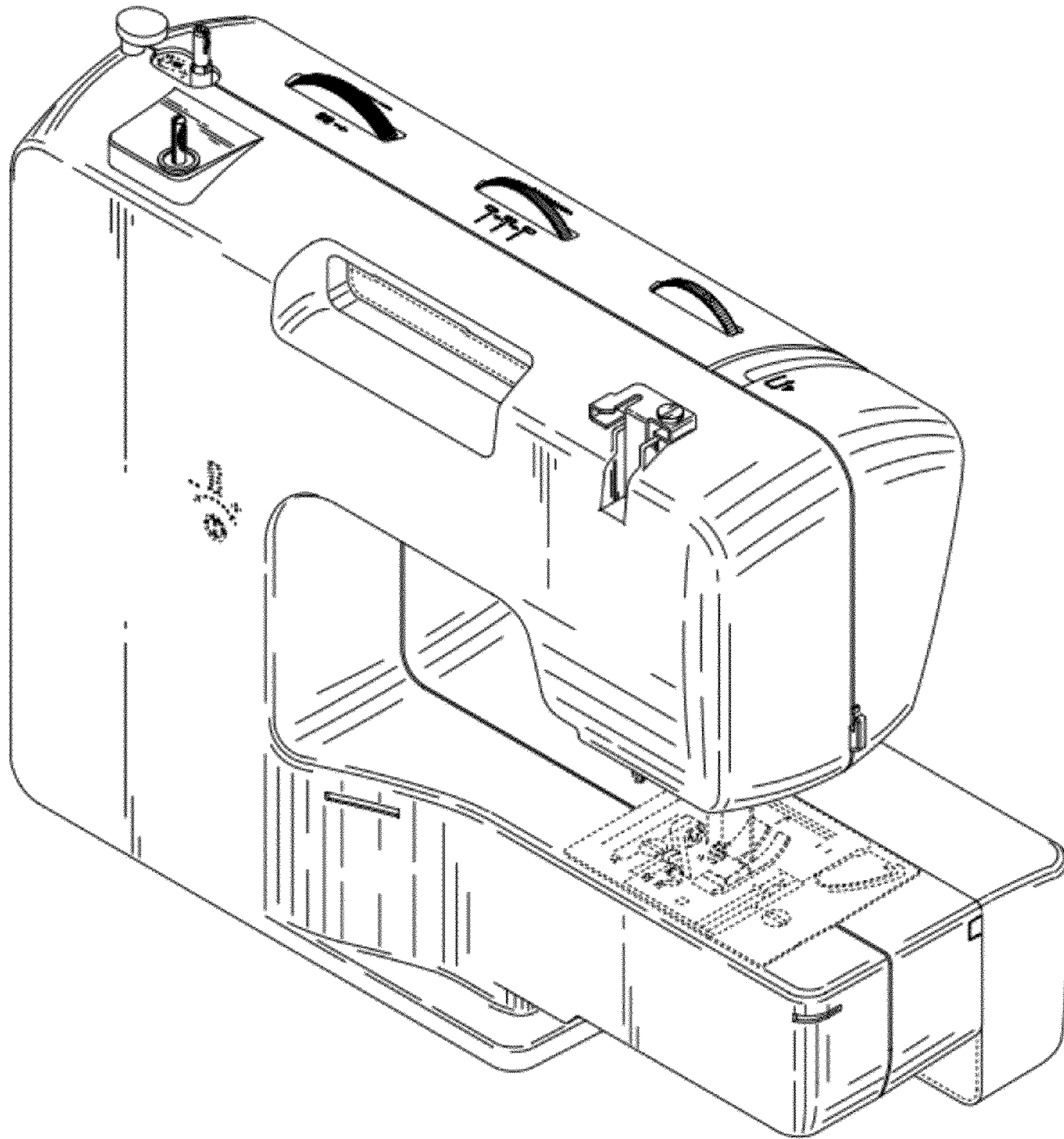

FIG. 8