

US00D663747S

(12) **United States Design Patent**
Marini

(10) **Patent No.:** **US D663,747 S**

(45) **Date of Patent:** **** Jul. 17, 2012**

(54) **FITTING FOR TYRE INFLATION AND TYRE REPAIR**

(75) Inventor: **Maurizio Marini**, Pesaro (IT)

(73) Assignee: **Tek Global S.r.l.**, Pesaro (IT)

(**) Term: **14 Years**

(21) Appl. No.: **29/353,683**

(22) Filed: **Jan. 13, 2010**

(30) **Foreign Application Priority Data**

Jul. 13, 2009 (EM) 001151799

(51) **LOC (9) Cl.** **15-02**

(52) **U.S. Cl.** **D15/9**

(58) **Field of Classification Search** D15/7-9;
D23/231, 232, 225; 417/60, 235, 265, 321,
417/355, 358, 363, 359, 410.1, 415-416,
417/405, 900; 60/408, 412; 184/26-37;
415/140-147; 123/495, 509

See application file for complete search history.

(56) **References Cited**

U.S. PATENT DOCUMENTS

D327,274 S * 6/1992 Matre et al. D15/7
D375,505 S * 11/1996 Wong D15/9
D515,103 S * 2/2006 Chou D15/9
D534,447 S * 1/2007 Marini D10/86

D540,820 S * 4/2007 Gilroy D15/7
D557,299 S * 12/2007 Marini et al. D15/199
D588,160 S * 3/2009 Beale et al. D15/7
D613,320 S * 4/2010 Marini D15/199
D626,970 S * 11/2010 Moser et al. D15/9
D630,229 S * 1/2011 Dreifert D15/7
D641,765 S * 7/2011 Vieira D15/9

* cited by examiner

Primary Examiner — Ralf Seifert

(74) *Attorney, Agent, or Firm* — Ladas & Parry LLP

(57) **CLAIM**

I claim the ornamental design for a fitting for tyre inflation and tyre repair, as shown and described.

DESCRIPTION

FIG. 1 is a top view of my new design for a fitting for tyre inflation and tyre repair
FIG. 2 is a bottom view thereof;
FIG. 3 is a front view thereof;
FIG. 4 is a rear view thereof;
FIG. 5 is a right side view thereof;
FIG. 6 is a left side view thereof; and,
FIG. 7 is a perspective view thereof from the front right side.
The broken lines in FIGS. 1, 2, 4 and 6 are included for the purpose of illustrating portions of fitting for tyre inflation and tyre repair that form no part of the claimed design.

1 Claim, 7 Drawing Sheets

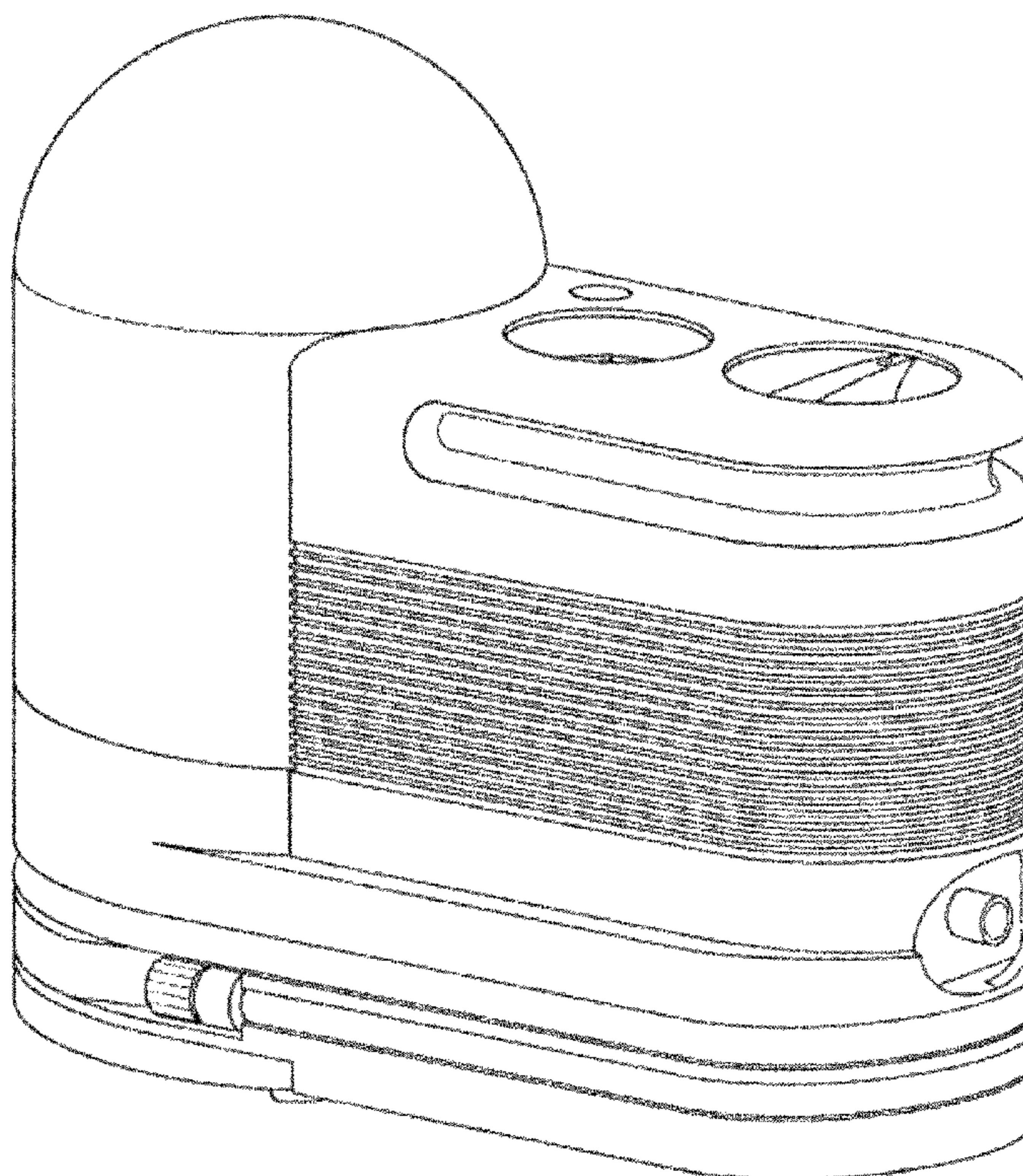

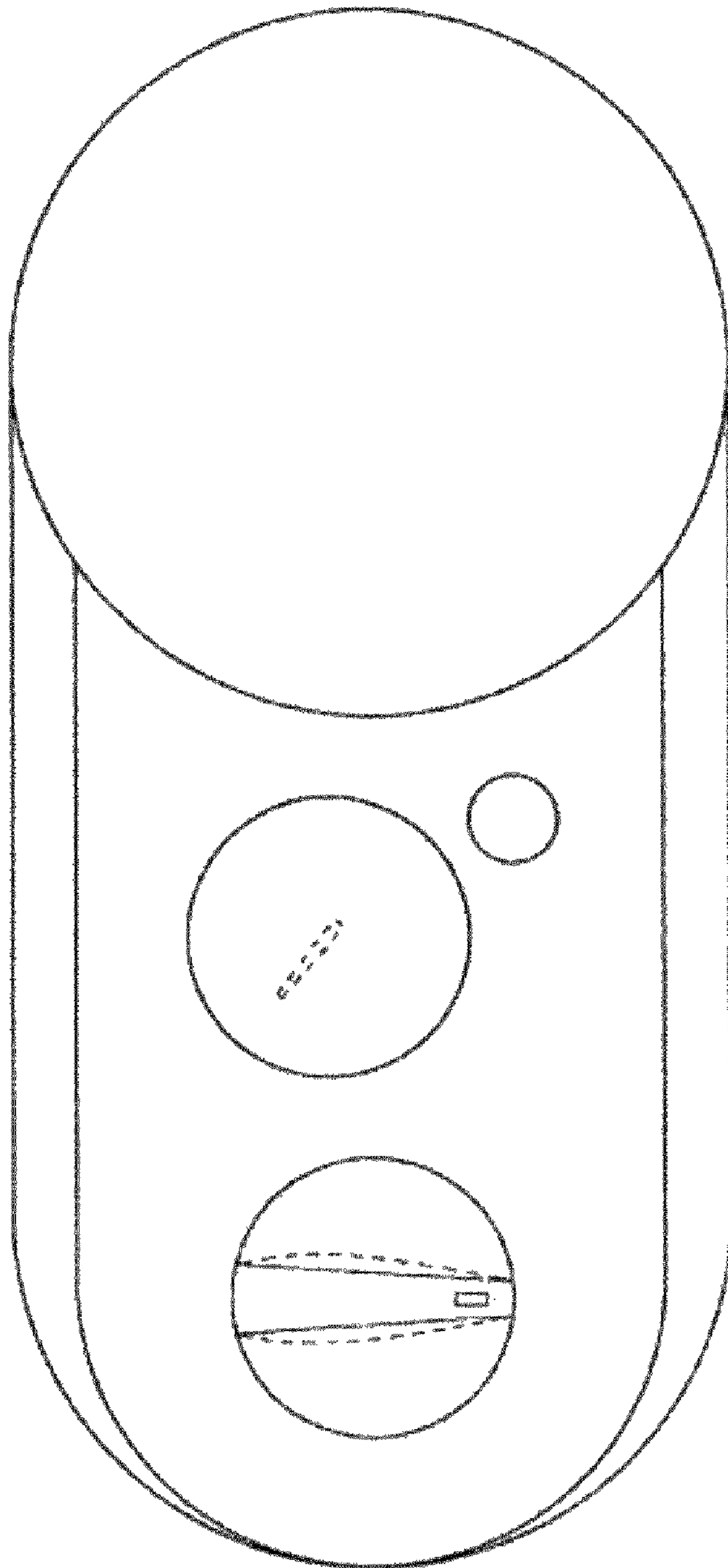

Fig. 1

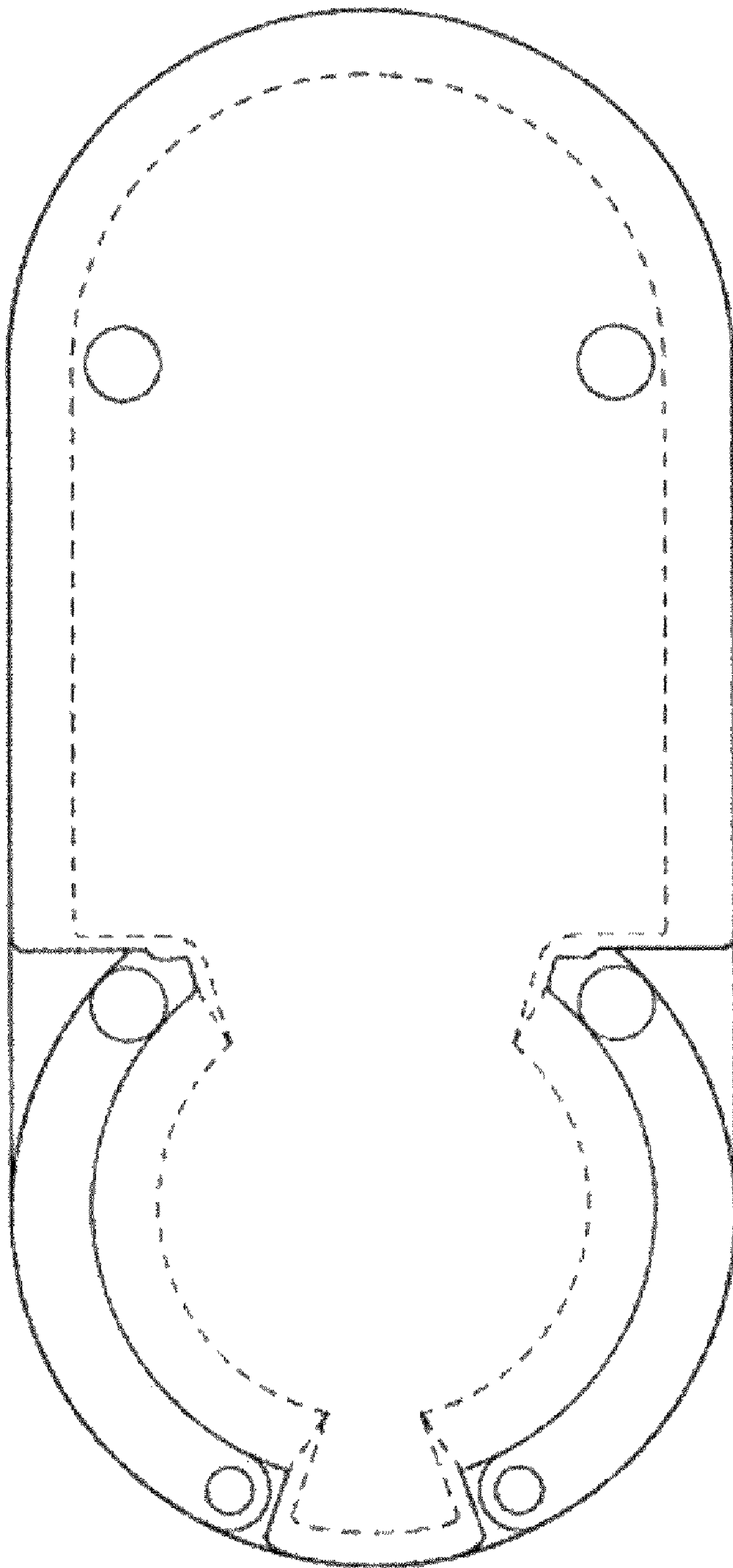

Fig. 2

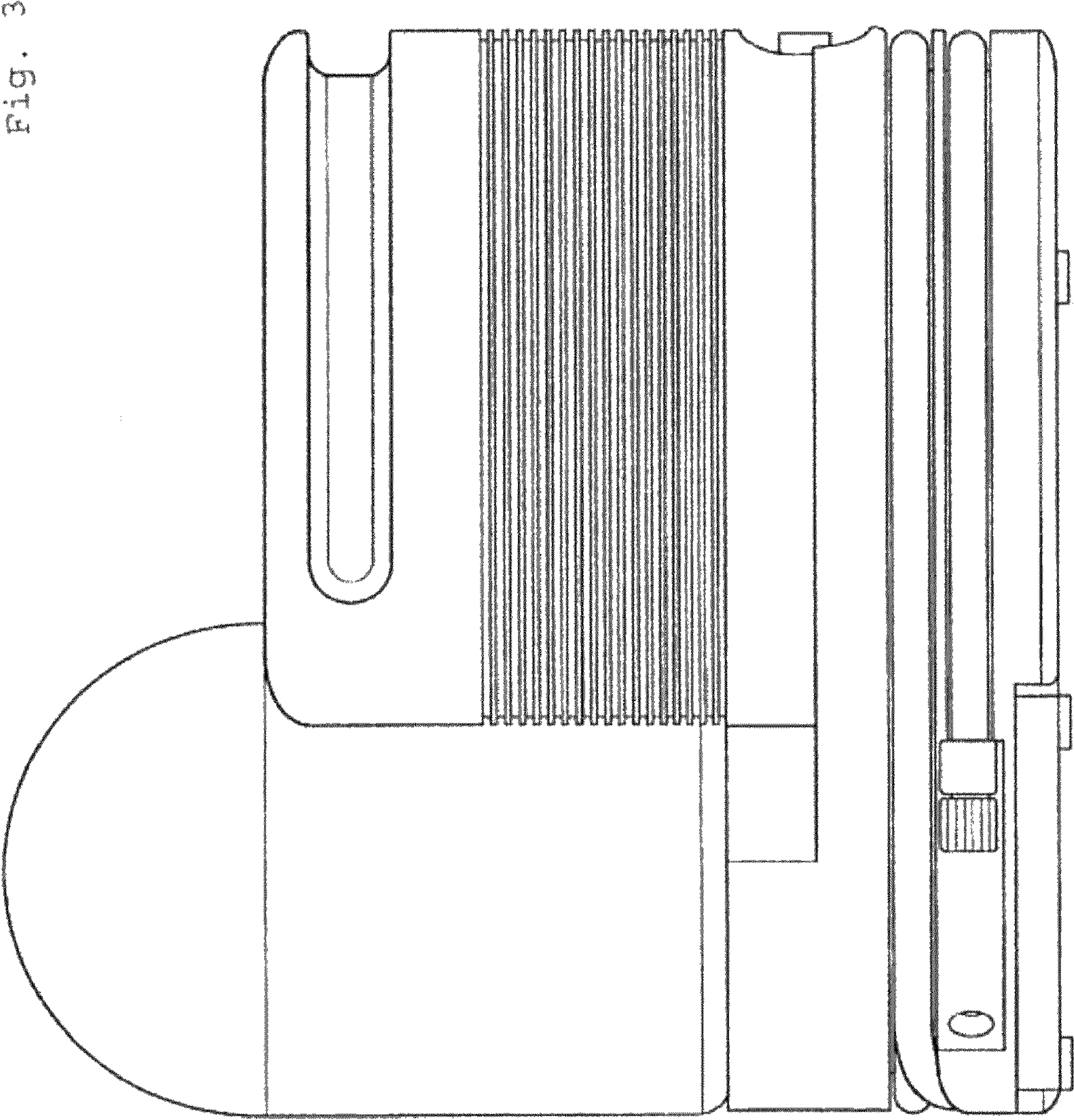
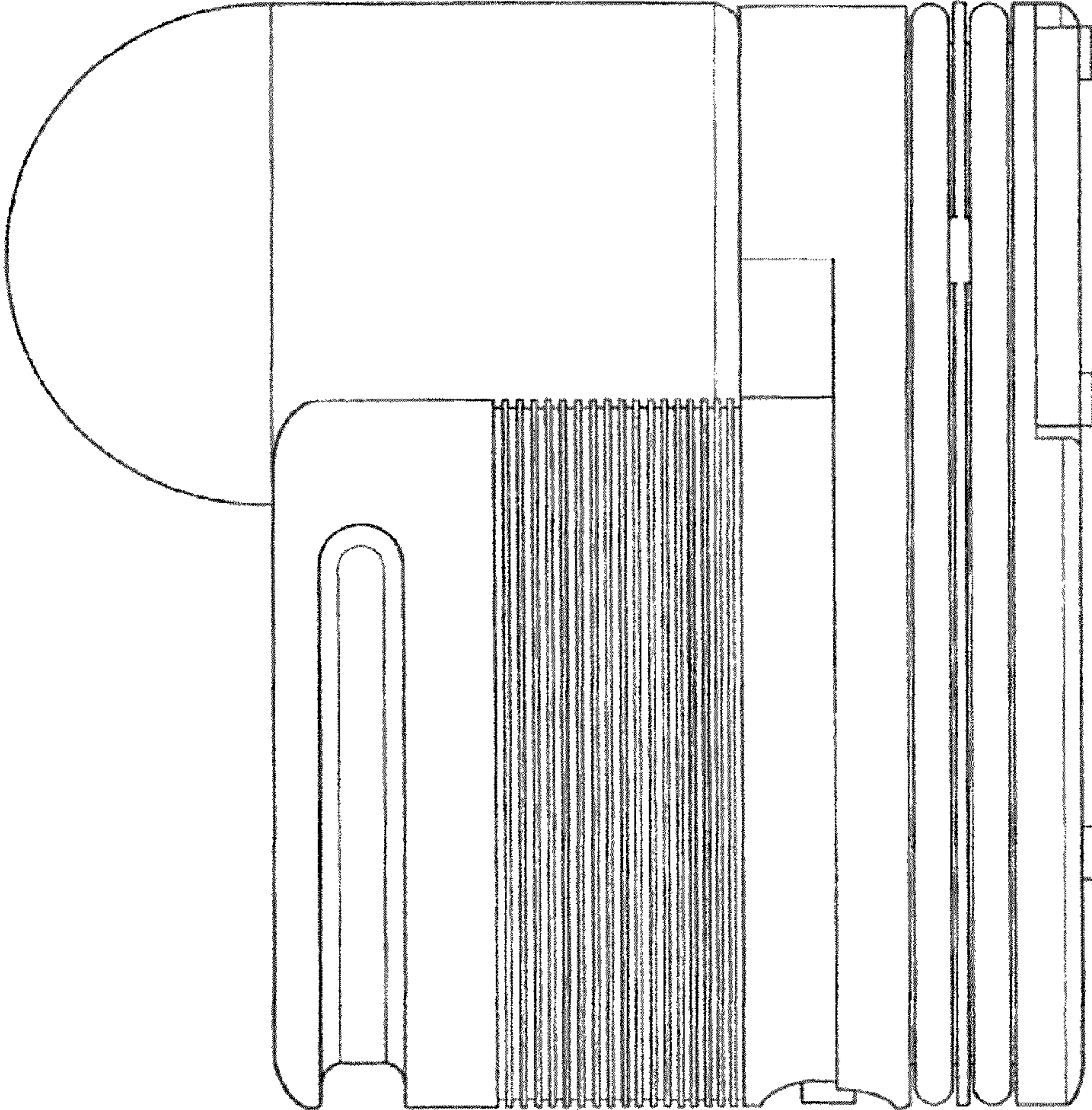

Fig. 3

Fig. 4



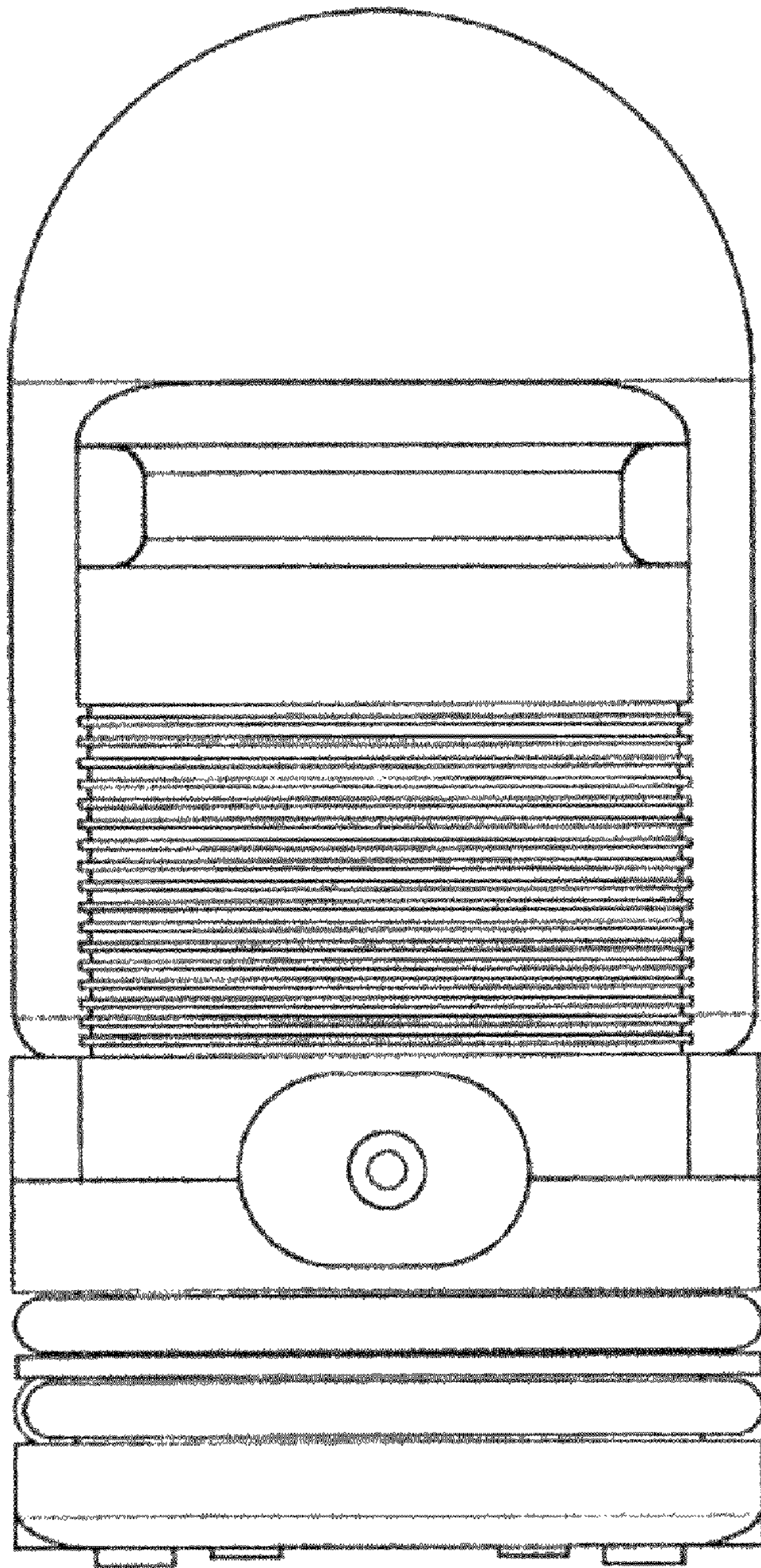

Fig. 5

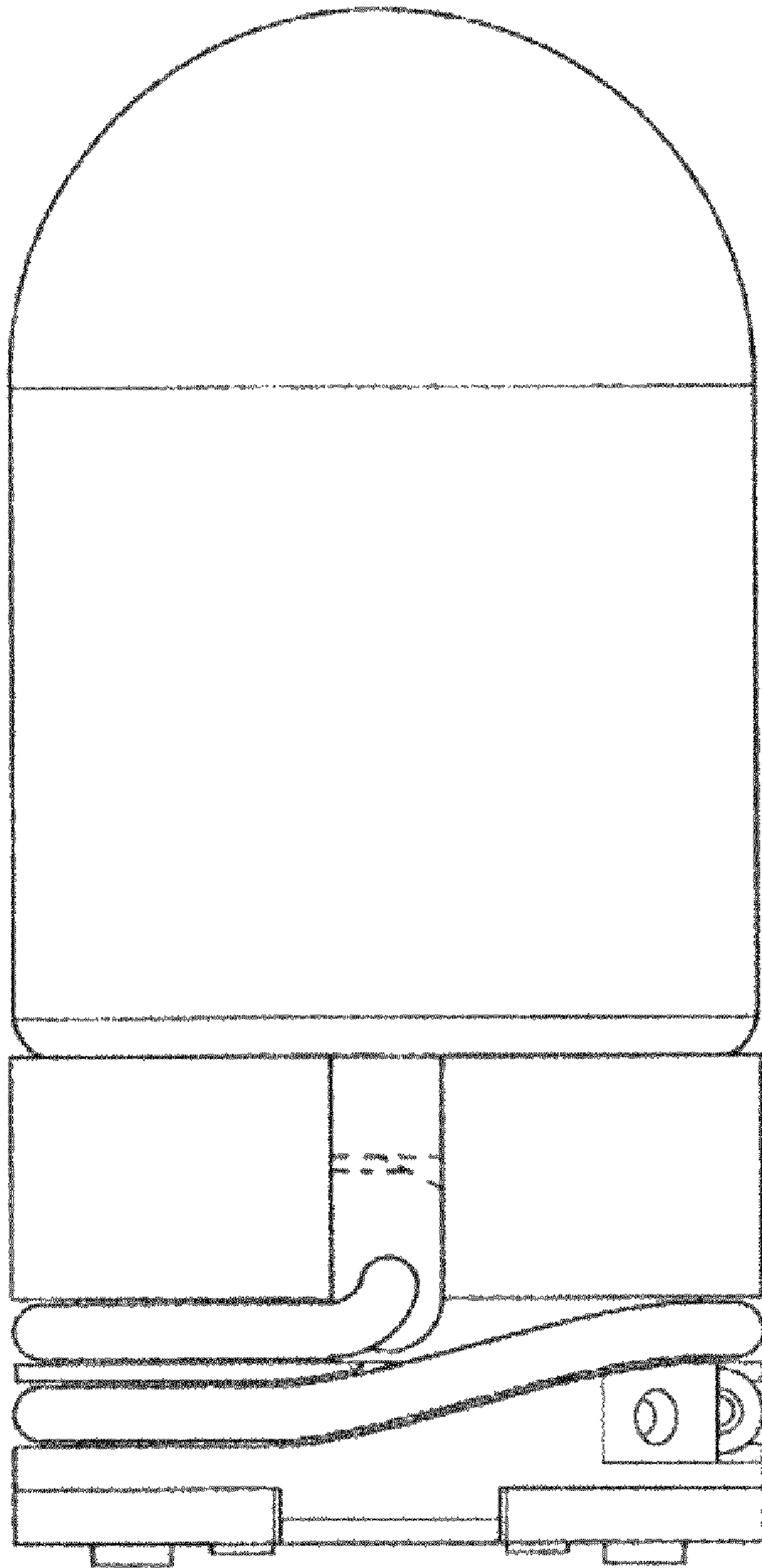

Fig. 6

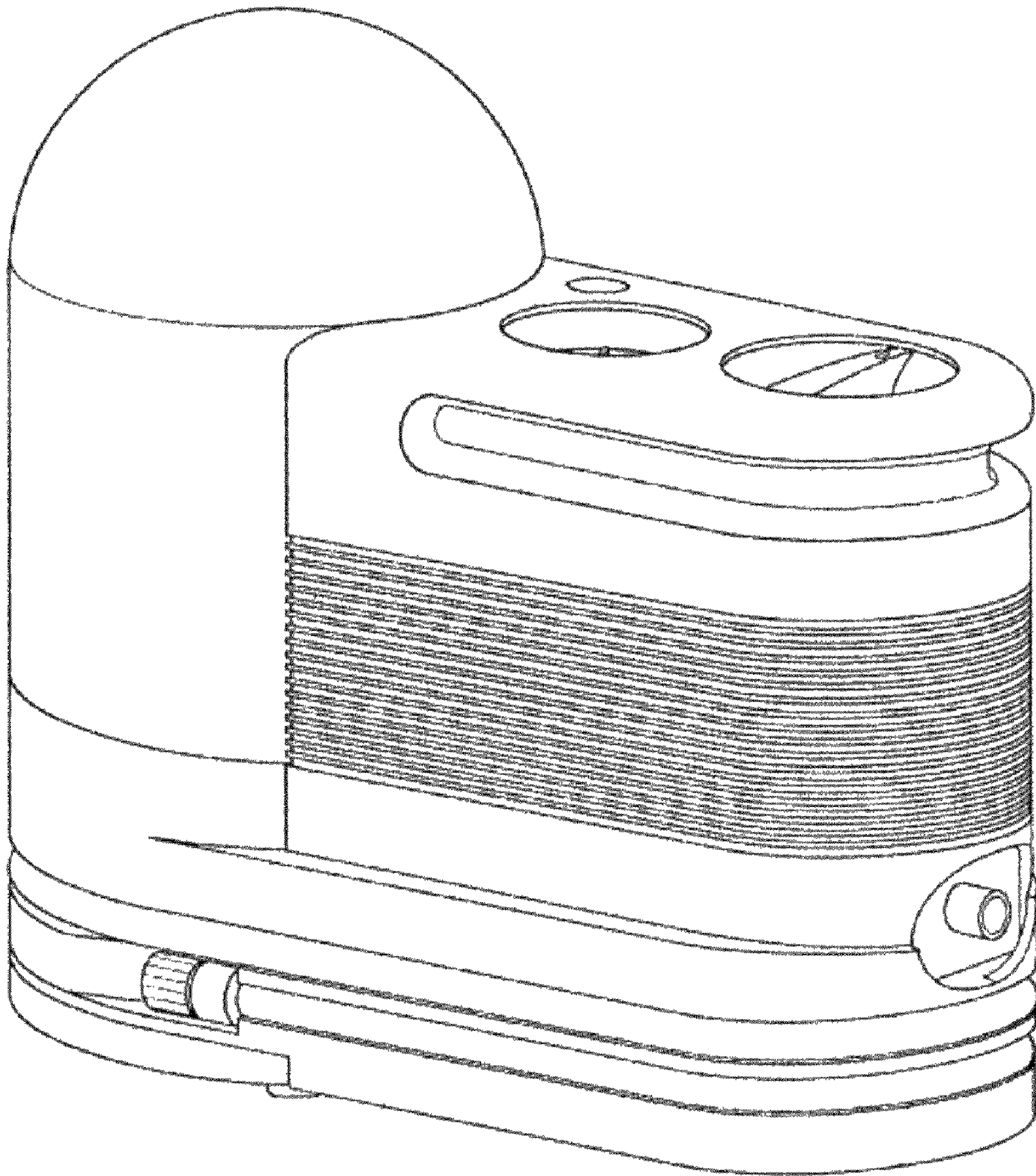

Fig. 7