



US00D663663S

(12) **United States Design Patent**
Perez

(10) **Patent No.:** **US D663,663 S**
(45) **Date of Patent:** **** Jul. 17, 2012**

(54) **VEHICLE LICENSE PLATE FRAME**

(76) Inventor: **Paul A. Perez**, Elk Grove, CA (US)

(**) Term: **14 Years**

(21) Appl. No.: **29/413,161**

(22) Filed: **Feb. 12, 2012**

(51) **LOC (9) Cl.** **12-16**

(52) **U.S. Cl.** **D12/193**

(58) **Field of Classification Search** D12/193,
D12/162; D6/300-302, 310-314; 40/200-204,
40/207-214; D20/13; 348/148, 373; D29/111
See application file for complete search history.

7,316,433 B2 1/2008 Levine
D591,666 S 5/2009 Valeri
D593,917 S * 6/2009 Spencer et al. D12/193
D601,070 S * 9/2009 Boyce D12/193
D625,234 S 10/2010 Vuletic
7,913,435 B1 3/2011 Hummel, III et al.
D641,300 S * 7/2011 Ferency D12/193
2011/0204595 A1 8/2011 Fox

* cited by examiner

Primary Examiner — Stacia Cadmus

(74) *Attorney, Agent, or Firm* — Dennis A. DeBoo

(57) **CLAIM**

The ornamental design for a vehicle license plate frame, as shown and described.

DESCRIPTION

FIG. 1 is a front perspective view of a vehicle license plate frame, showing my new design;
FIG. 2 is a front elevational view thereof;
FIG. 3 is a right side elevational view thereof, the left side being a mirror image;
FIG. 4 is a top view thereof;
FIG. 5 is a bottom view thereof;
FIG. 6 is a rear elevational view thereof; and,
FIG. 7 is a rear perspective view thereof.

1 Claim, 3 Drawing Sheets

(56) **References Cited**

U.S. PATENT DOCUMENTS

D131,351 S * 2/1942 Knapke D12/193
4,011,675 A 3/1977 Herring
4,956,930 A 9/1990 Troncoso
D318,838 S 8/1991 Troncoso
D365,077 S * 12/1995 Lee D12/193
D366,236 S * 1/1996 Chu D12/193
D381,127 S * 7/1997 Rothwell D29/111
D413,291 S 8/1999 Corns, Jr.
D441,332 S * 5/2001 McBroom et al. D12/193
D463,885 S * 10/2002 Burns D29/111
D477,799 S * 7/2003 Arens D12/193

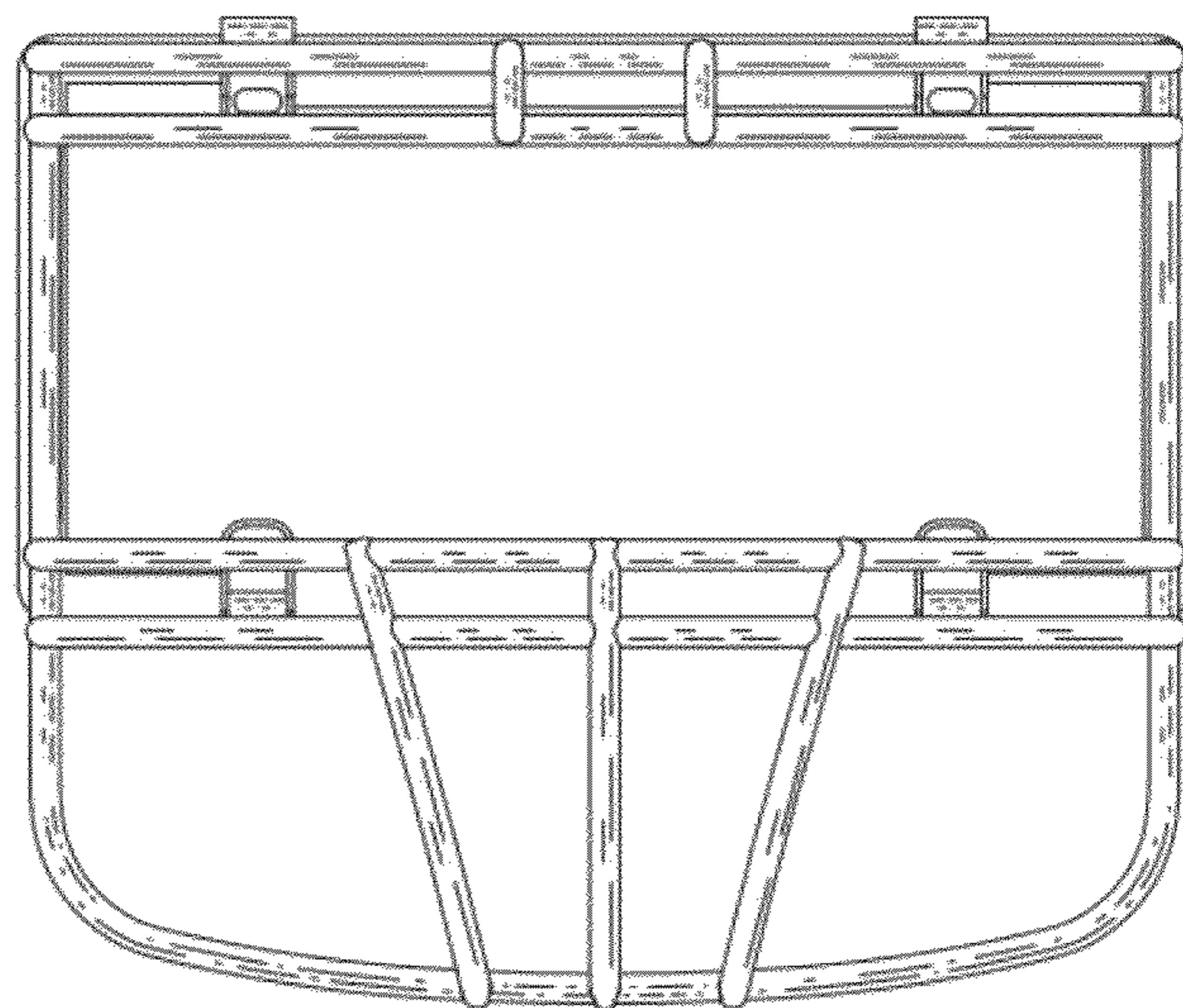



Fig. 1

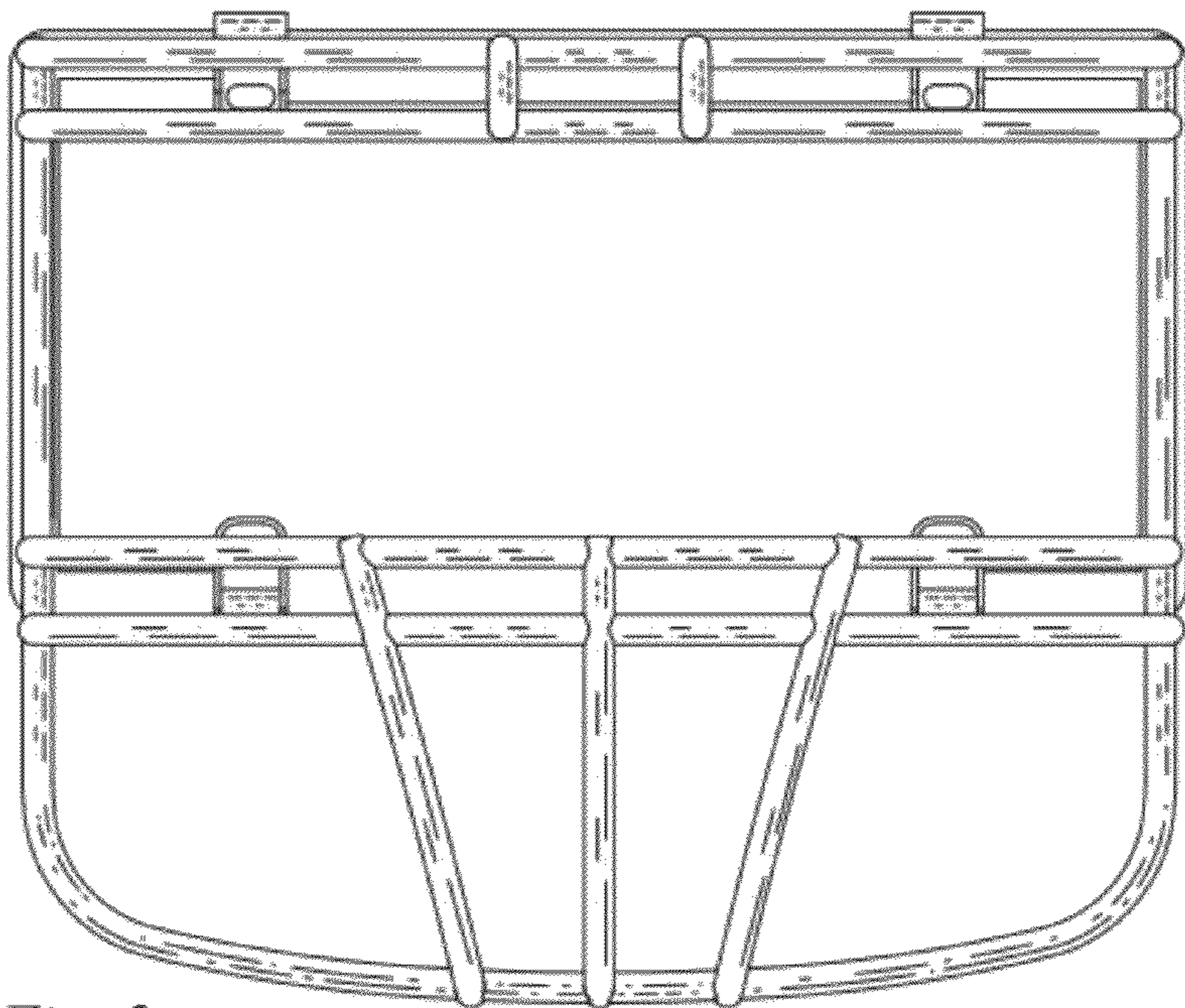

Fig. 2

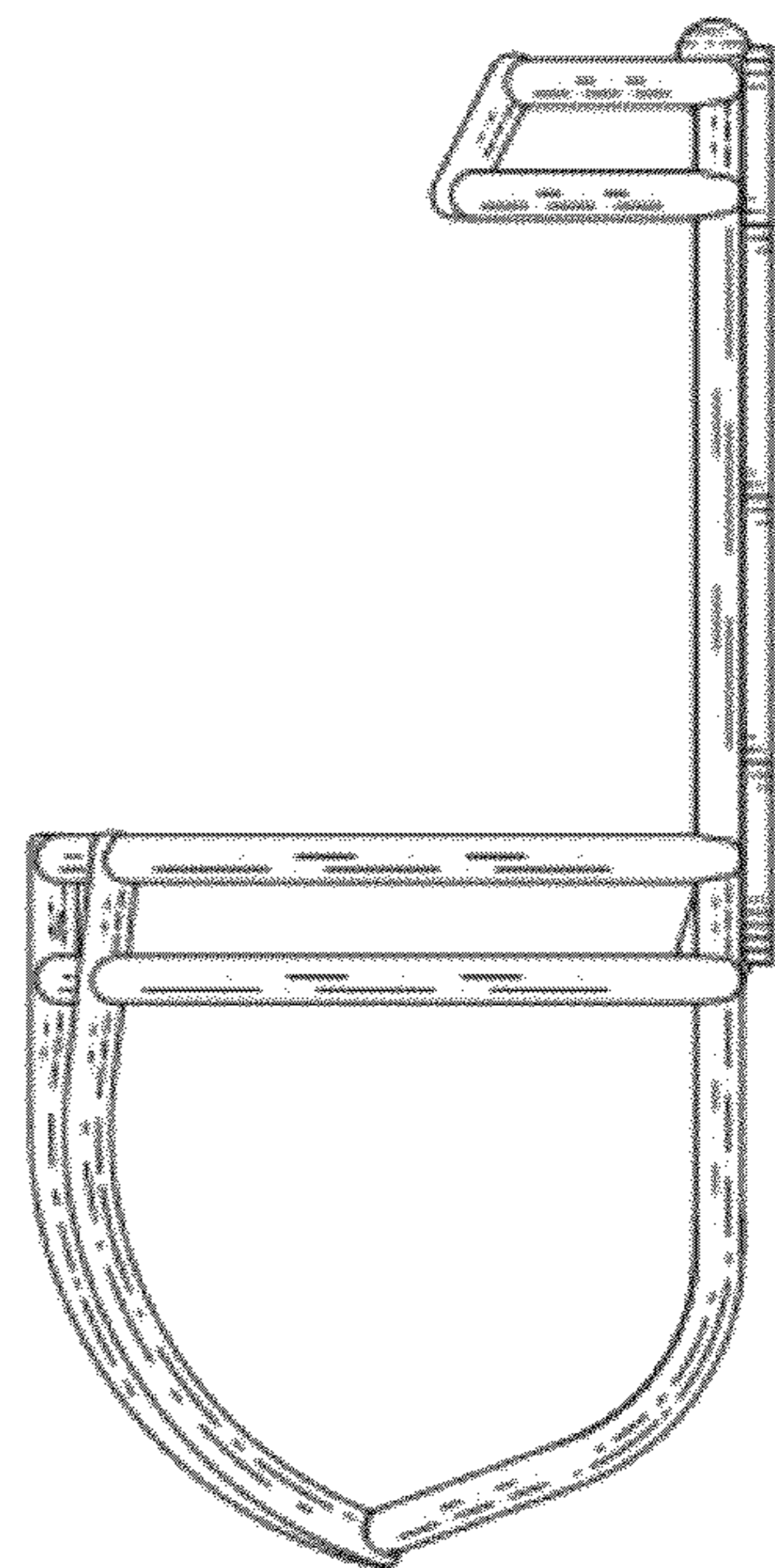

Fig. 3

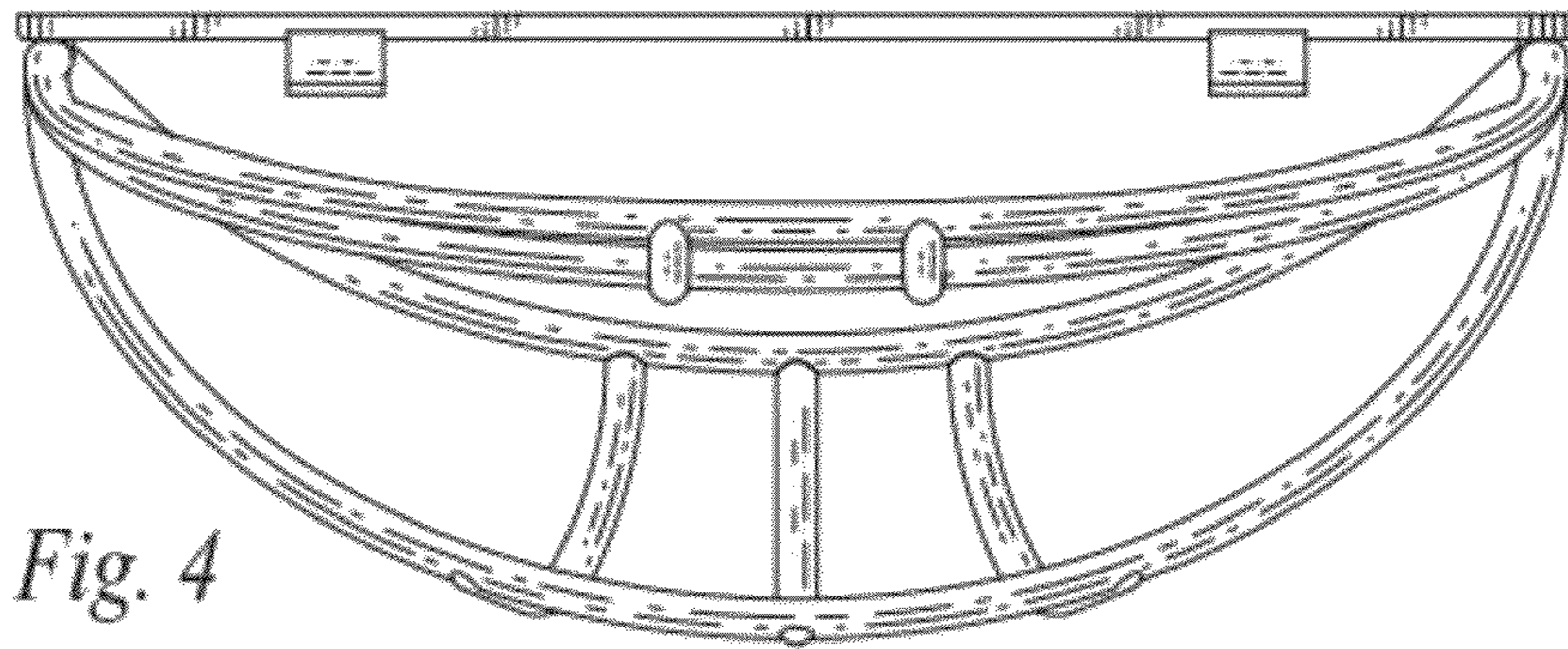

Fig. 4

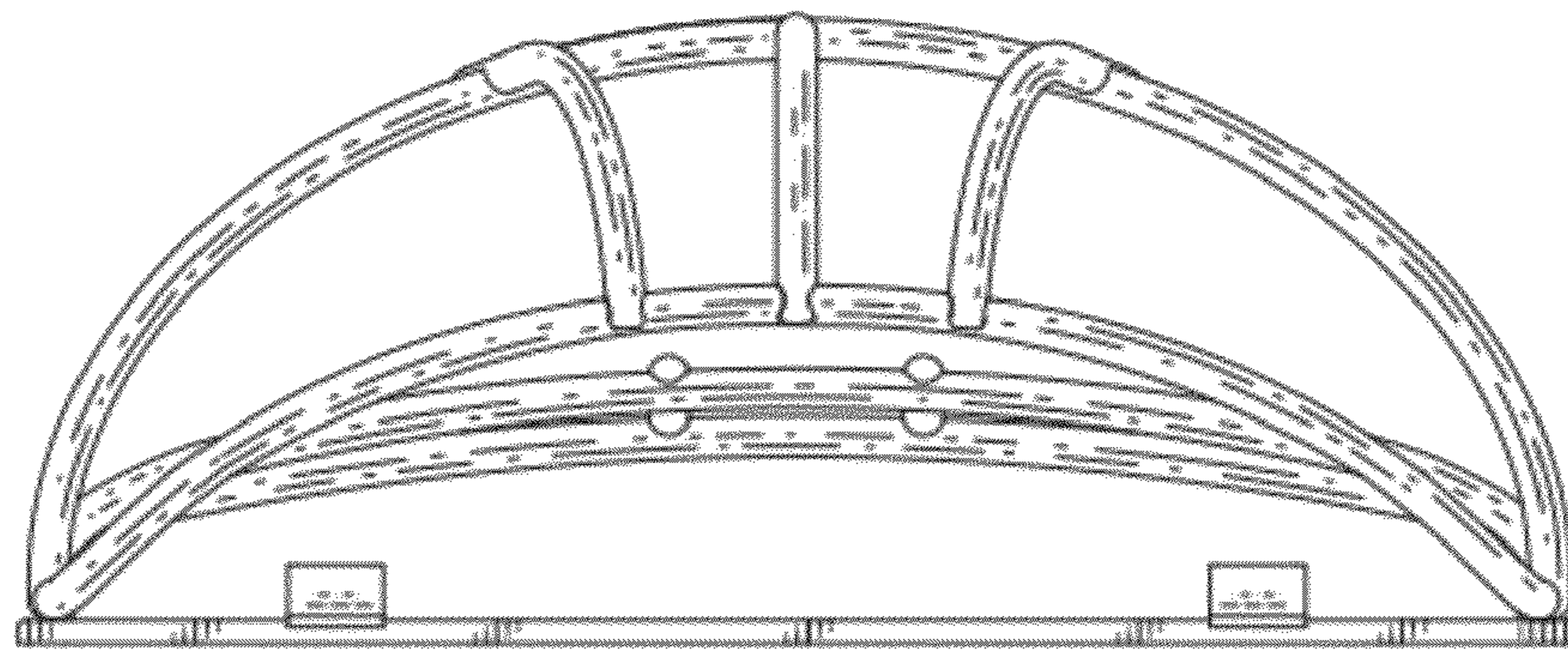

Fig. 5

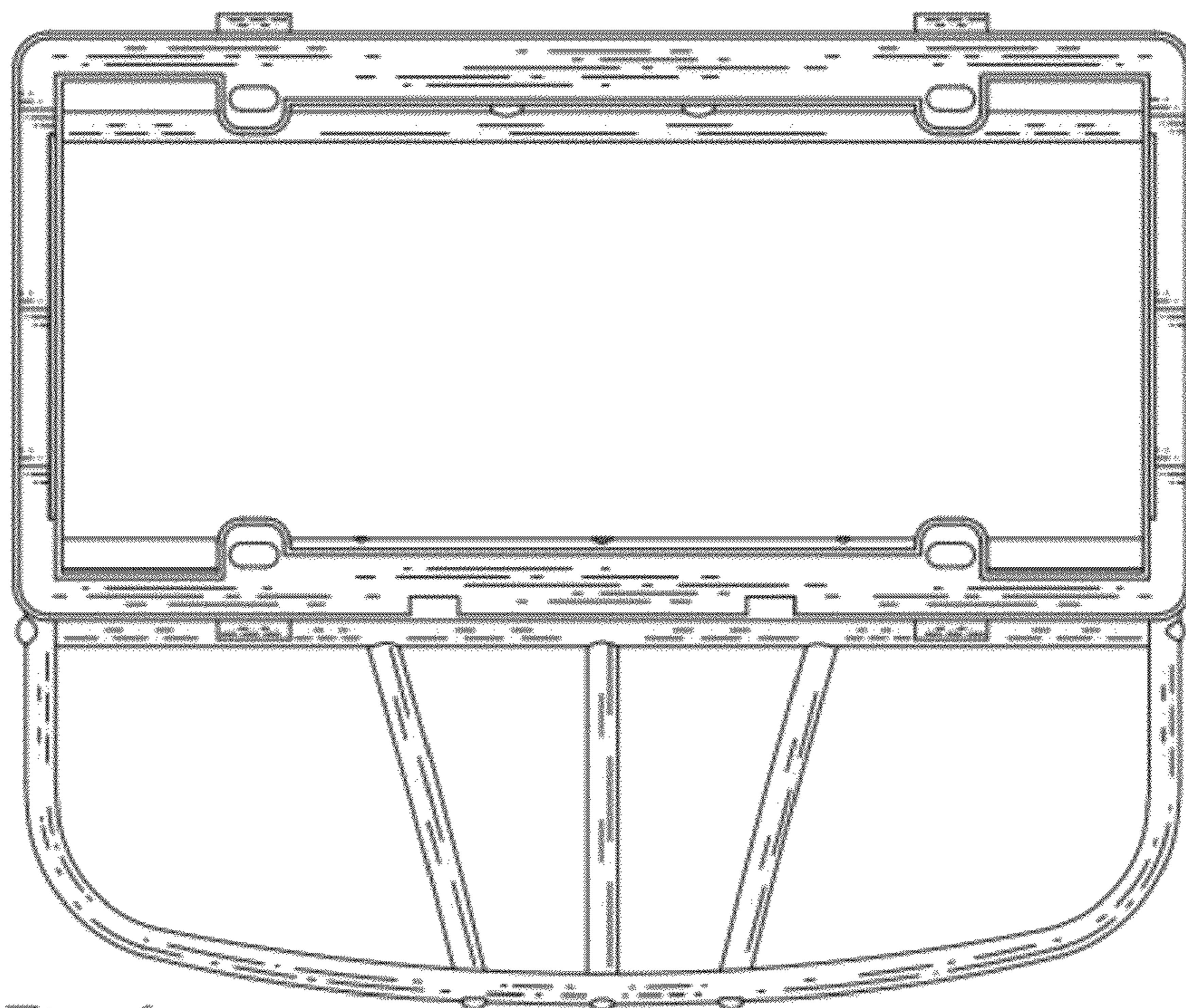

Fig. 6

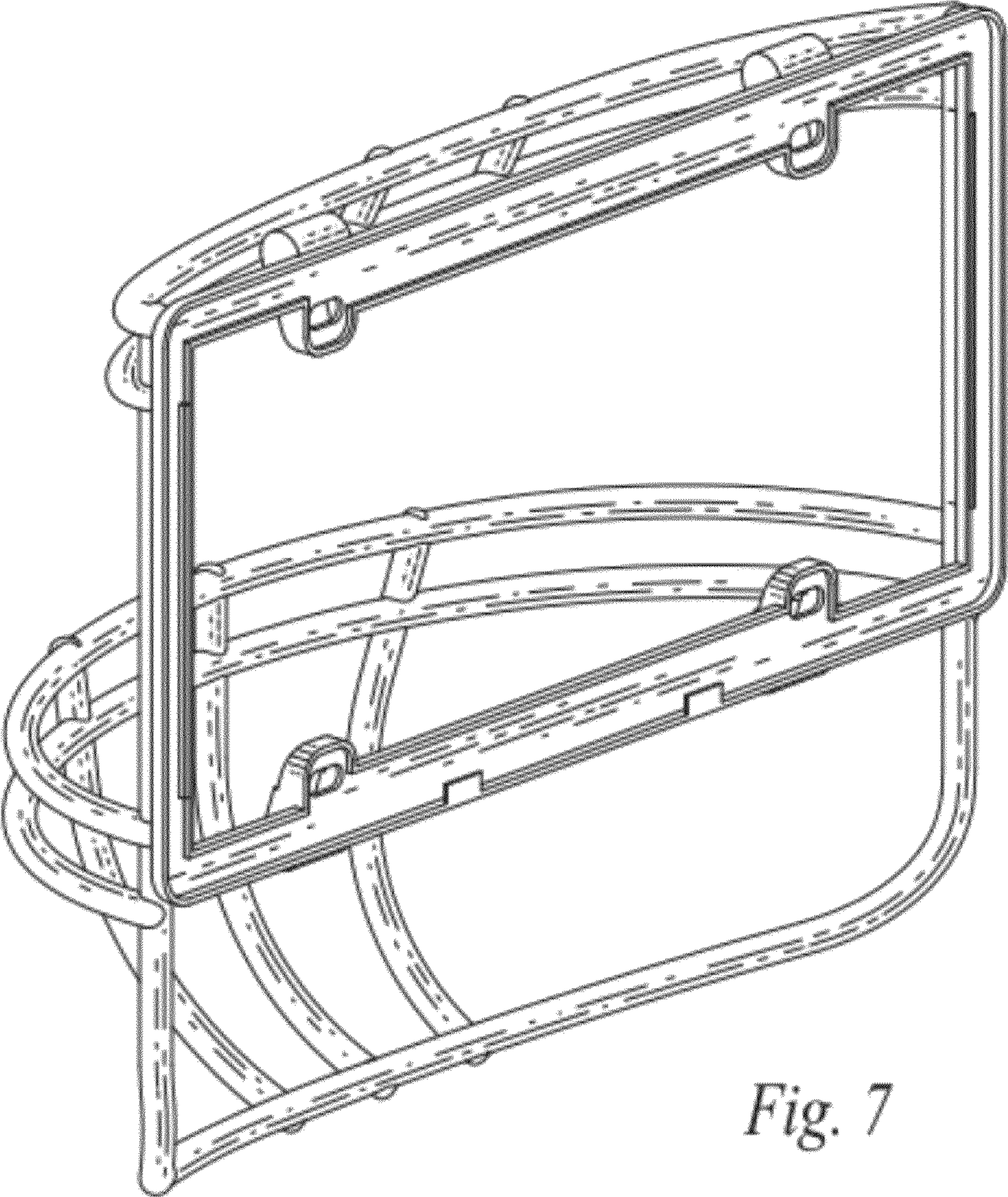

Fig. 7