



US00D663654S

(12) **United States Design Patent**
Wanger et al.

(10) **Patent No.:** **US D663,654 S**
(45) **Date of Patent:** **** Jul. 17, 2012**

(54) **PROPULSION TRAILER**

(75) Inventors: **Mark E. Wanger**, Fort Collins, CO (US); **Donald H. Eason**, Fort Collins, CO (US)

(73) Assignee: **DMK Colorado, LLC**, Fort Collins, CO (US)

(**) Term: **14 Years**

(21) Appl. No.: **29/398,739**

(22) Filed: **Aug. 3, 2011**

(51) **LOC (9) Cl.** **12-10**

(52) **U.S. Cl.** **D12/102**

(58) **Field of Classification Search** D12/100-106,
D12/19, 129; D21/425, 435; D34/21-26,
D34/12, 16; 280/204, 205, 63, 475, 482,
280/647;
296/168, 180, 180.2, 10, 61, 100.01-100.08
See application file for complete search history.

(56) **References Cited**

U.S. PATENT DOCUMENTS

D265,301	S	*	7/1982	Zander	D12/102
4,413,692	A	*	11/1983	Cliff	180/11
D326,629	S	*	6/1992	Holler et al.	D12/102
D367,248	S	*	2/1996	Christensen	D12/102
D390,166	S	*	2/1998	Kass et al.	D12/102
5,816,349	A	*	10/1998	Hankins	180/11
6,725,955	B2		4/2004	Bidwell		
D601,059	S	*	9/2009	Greer	D12/101
D606,904	S	*	12/2009	Greer	D12/102
D625,666	S	*	10/2010	Treleven	D12/102
D628,126	S	*	11/2010	Tai	D12/106
D653,588	S	*	2/2012	Heard	D12/102

OTHER PUBLICATIONS

U.S. Appl. No. 61/179,536, filed May 19, 2009.

U.S. Appl. No. 61/180,846, filed May 23, 2009.
U.S. Appl. No. 61/250,863, filed Oct. 12, 2009.
U.S. Appl. No. 12/965,607, filed Dec. 10, 2010.
PCT International Patent Application PCT/US2010/035478, filed May 19, 2010.

* cited by examiner

Primary Examiner — Caron D Veynar

Assistant Examiner — Katrina A Betton

(74) *Attorney, Agent, or Firm* — Craig R. Miles; CR Miles, P.C.

(57) **CLAIM**

The ornamental design for a propulsion trailer, as shown and described.

DESCRIPTION

FIG. 1 is a side elevation view thereof showing the left side; FIG. 2 is a side elevation view thereof showing the right side; FIG. 3 is a front elevation view thereof showing the anterior side; FIG. 4 is a rear elevation view thereof showing the posterior side; FIG. 5 is a top plan view thereof; FIG. 6 is a bottom plan view thereof. FIG. 7 is a perspective view of the trailer showing the right frontal view of our new design; and, FIG. 8 is a perspective view of the trailer showing the left posterior view of our new design. The broken lines in the drawings depict probable environment only and form no part of the claimed design.

1 Claim, 4 Drawing Sheets

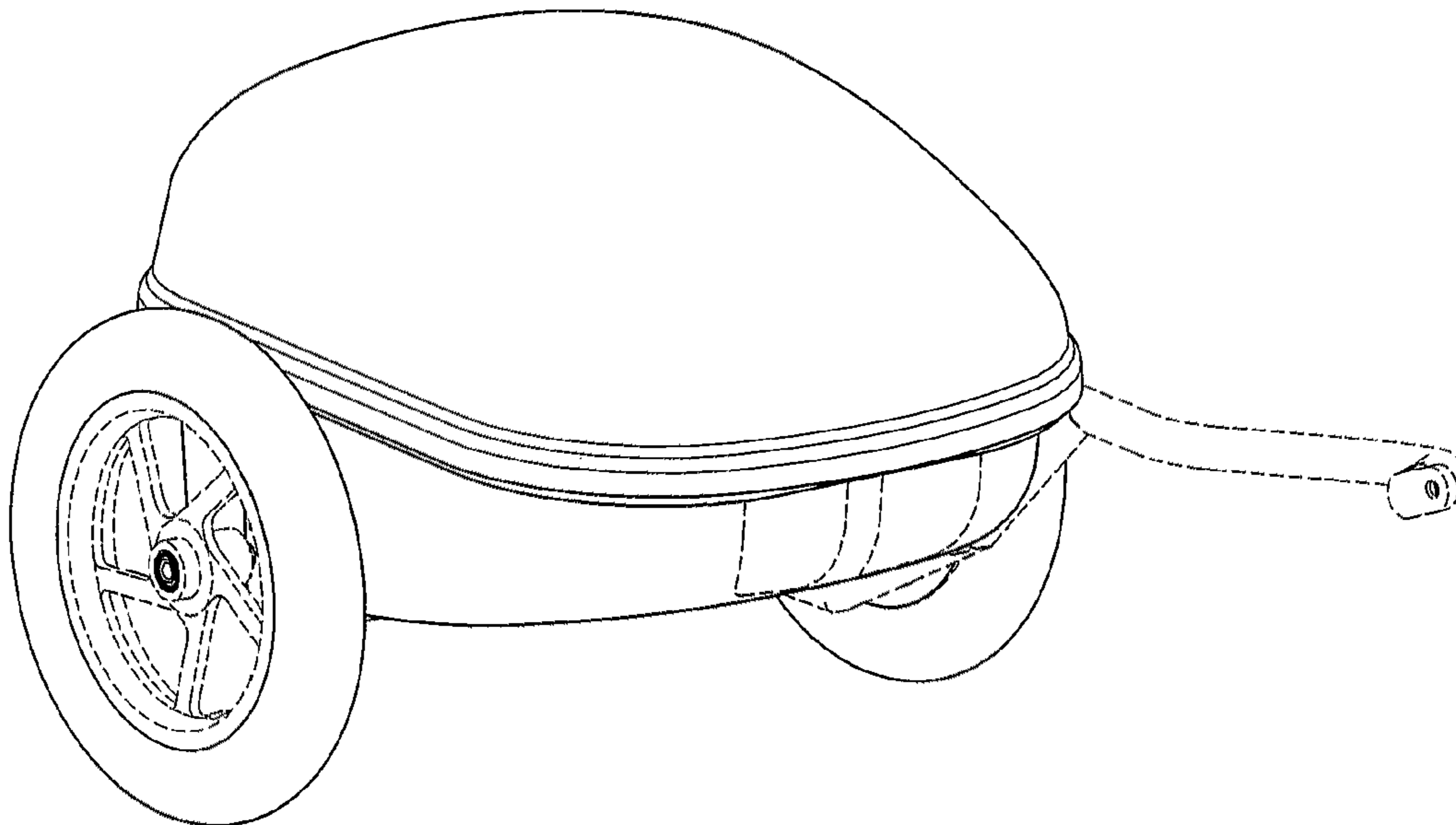

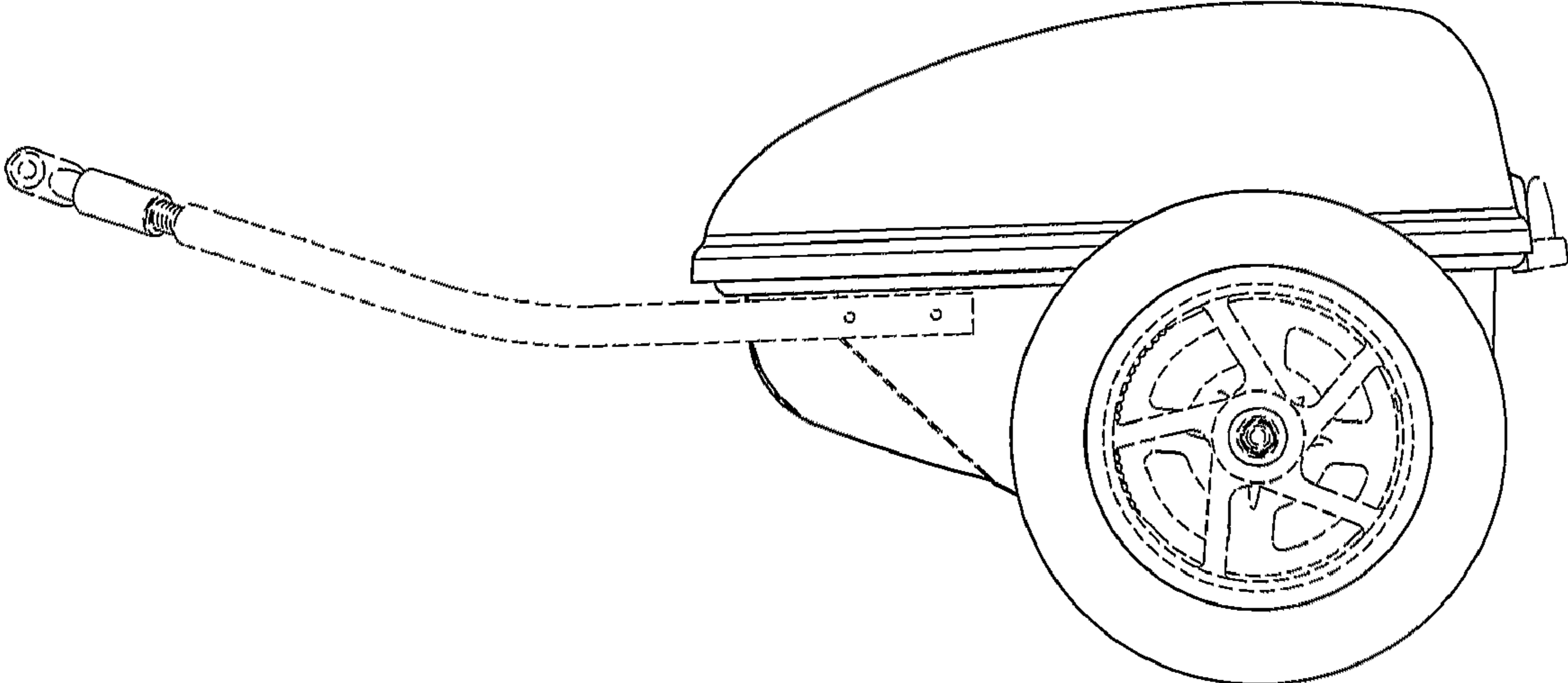

Fig. 1

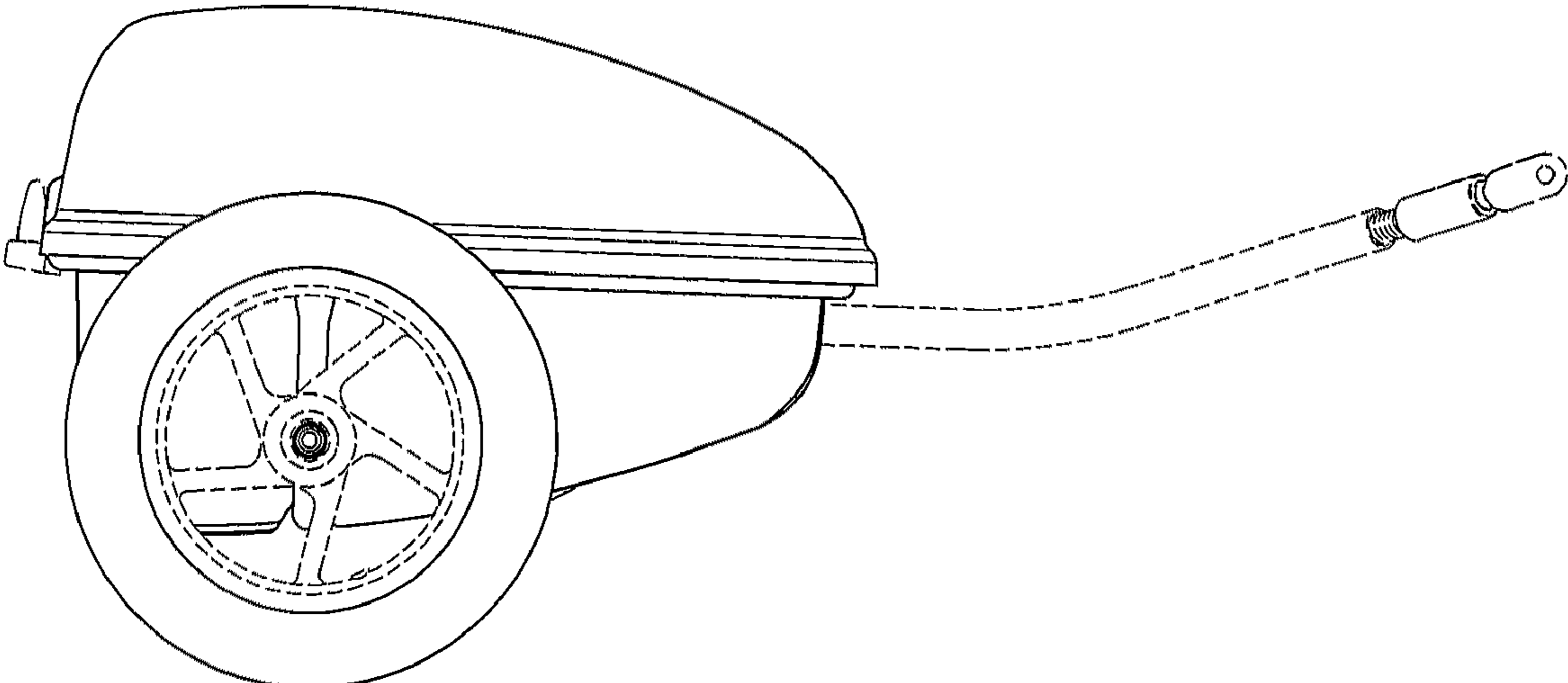

Fig. 2

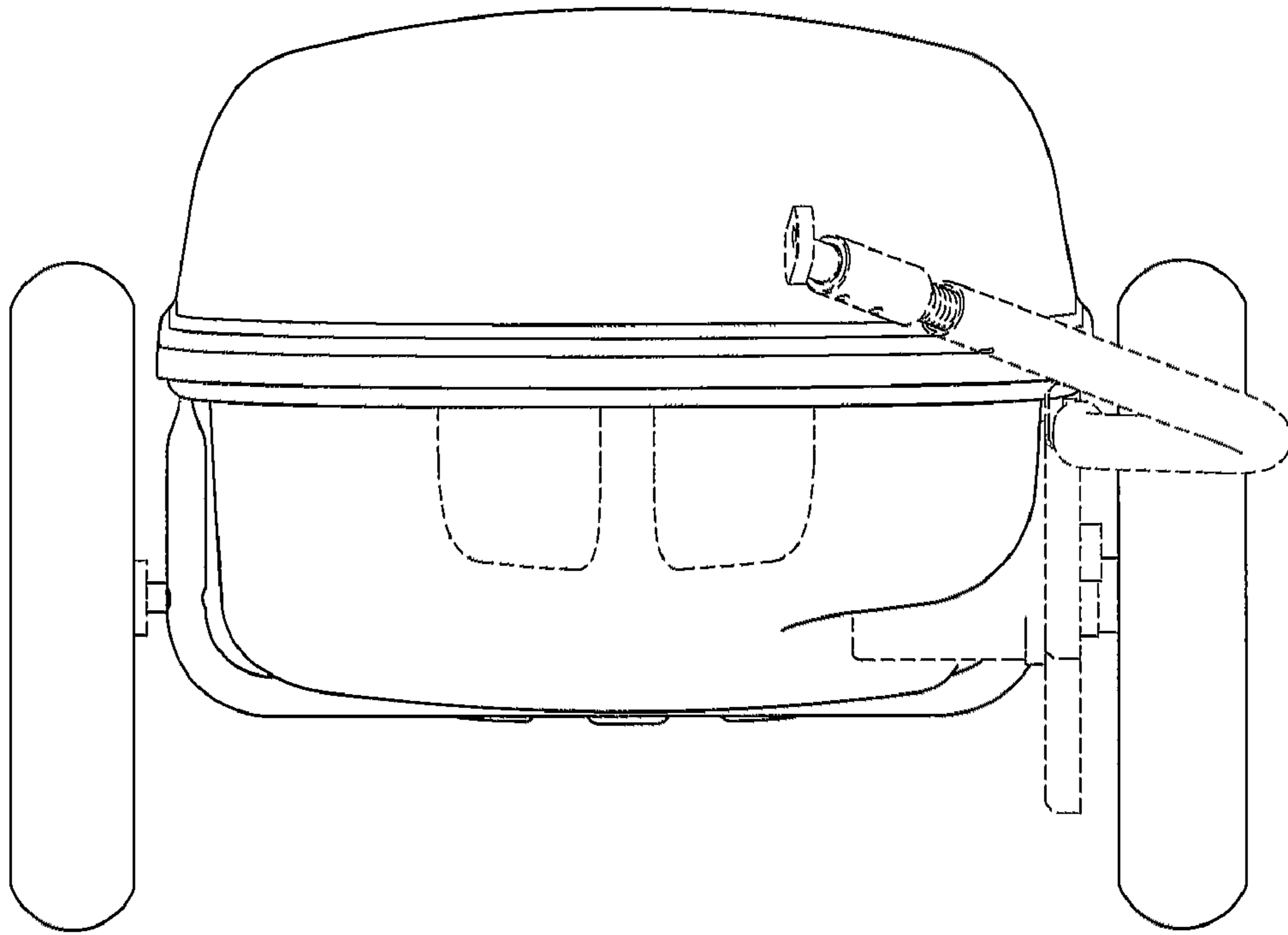

Fig. 3

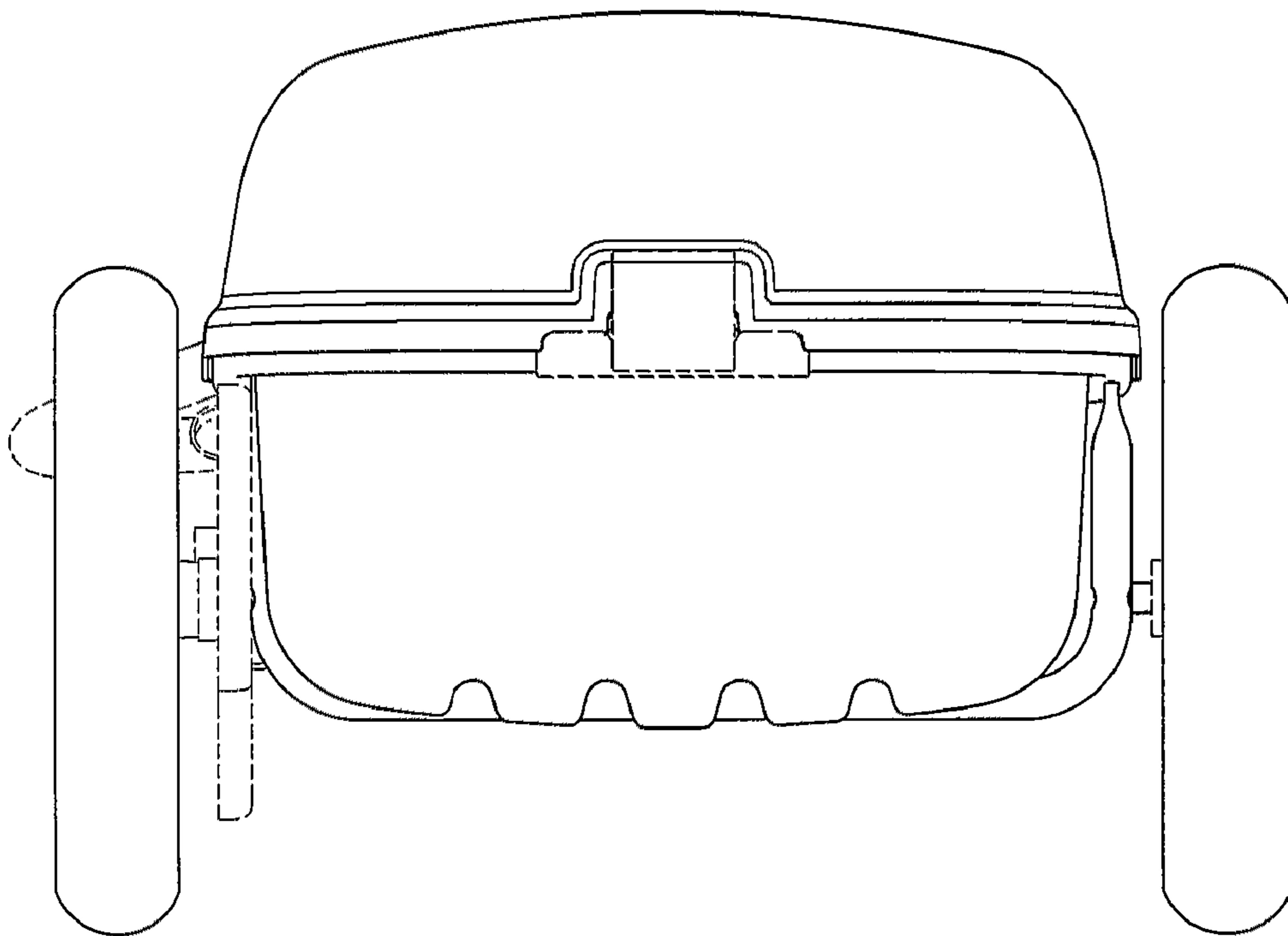

Fig. 4

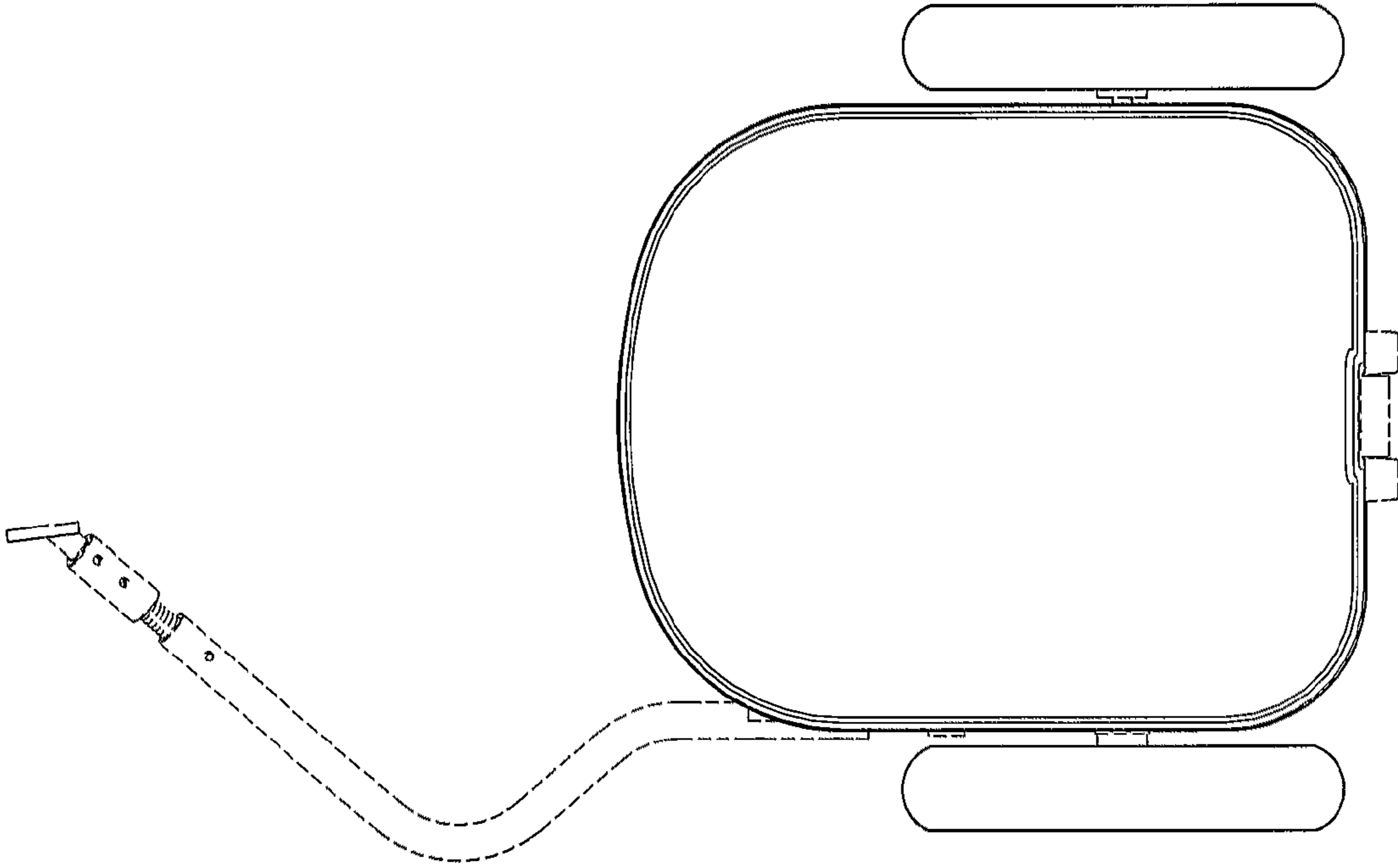

Fig. 5

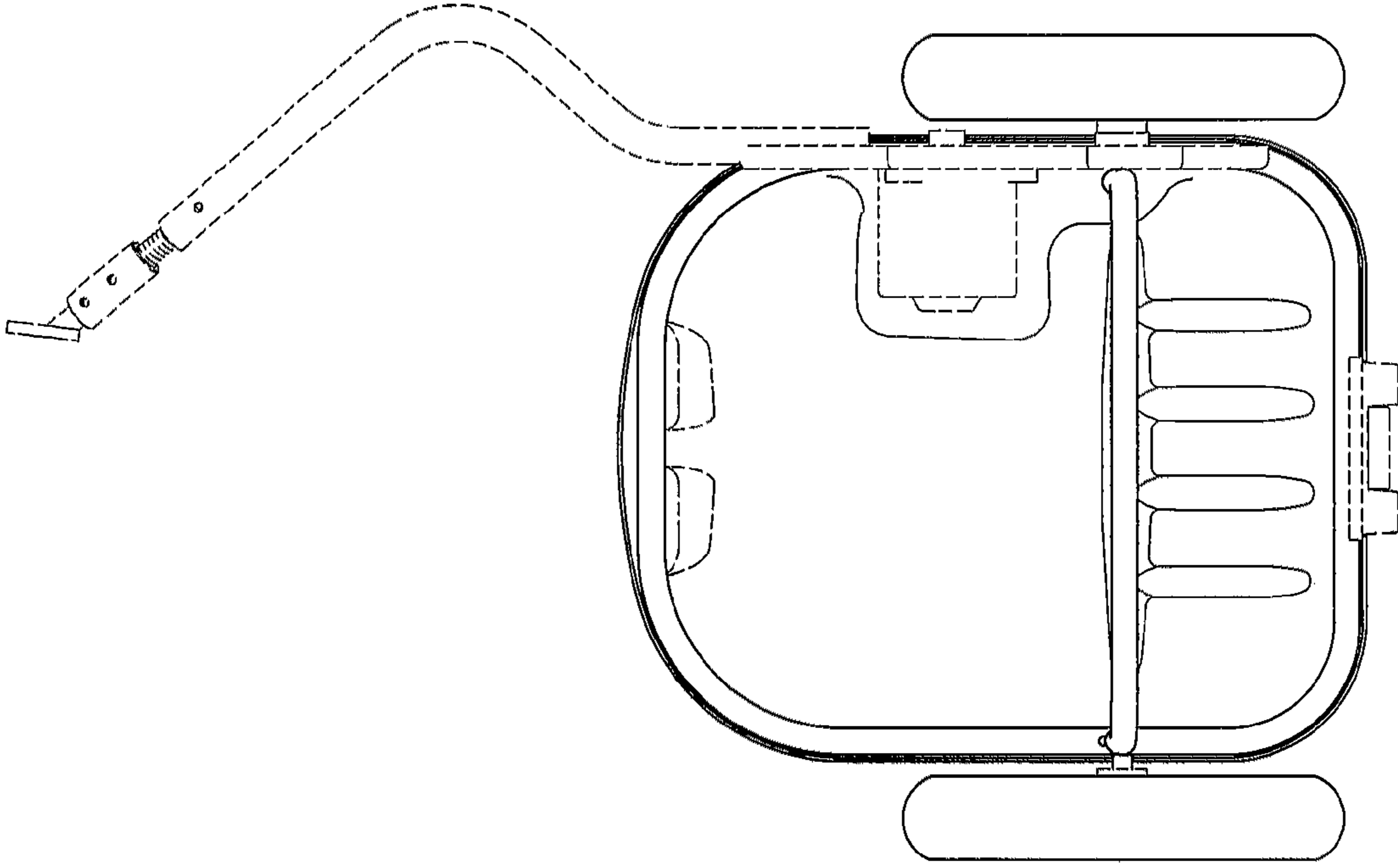

Fig. 6

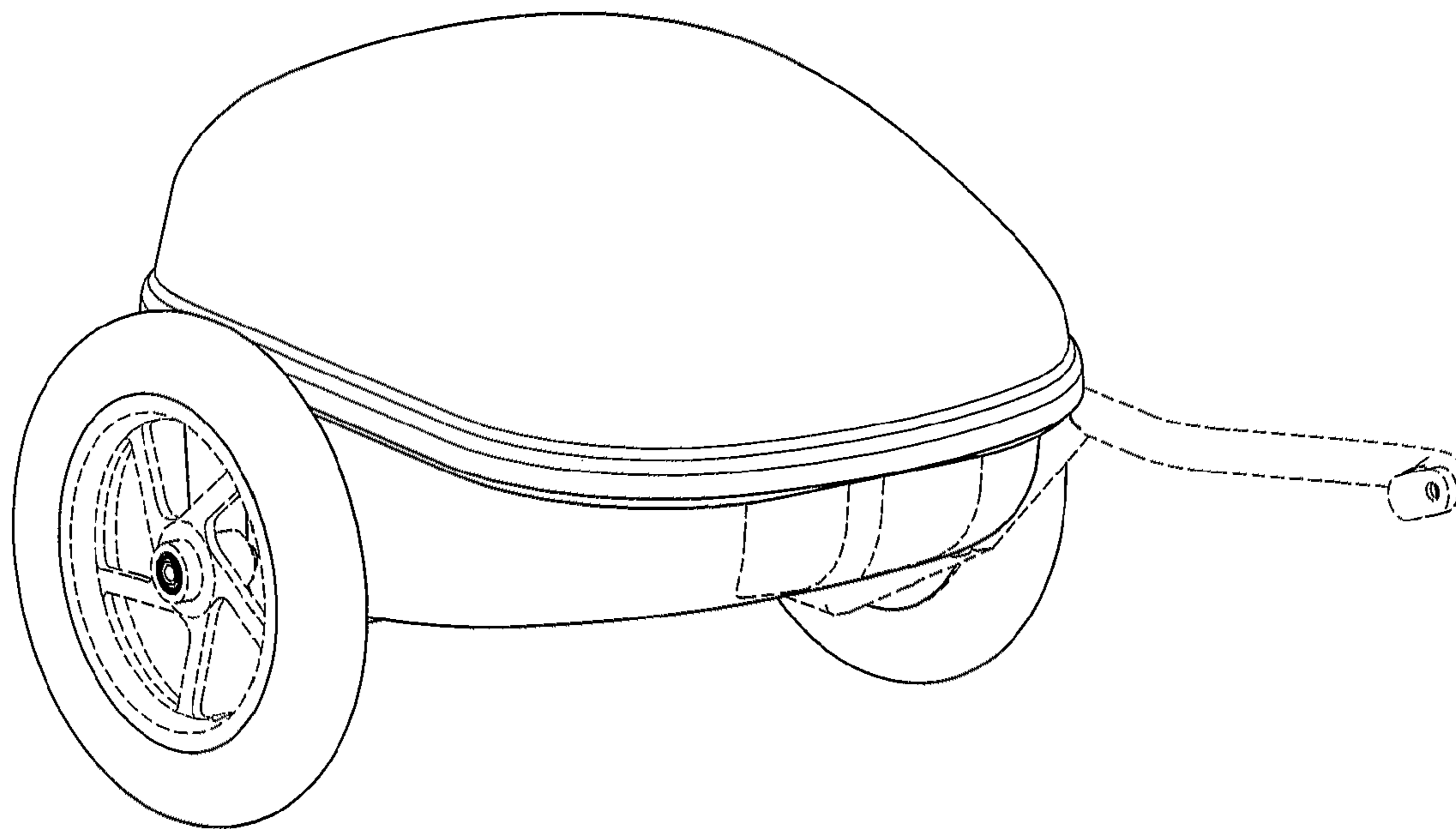

Fig. 7

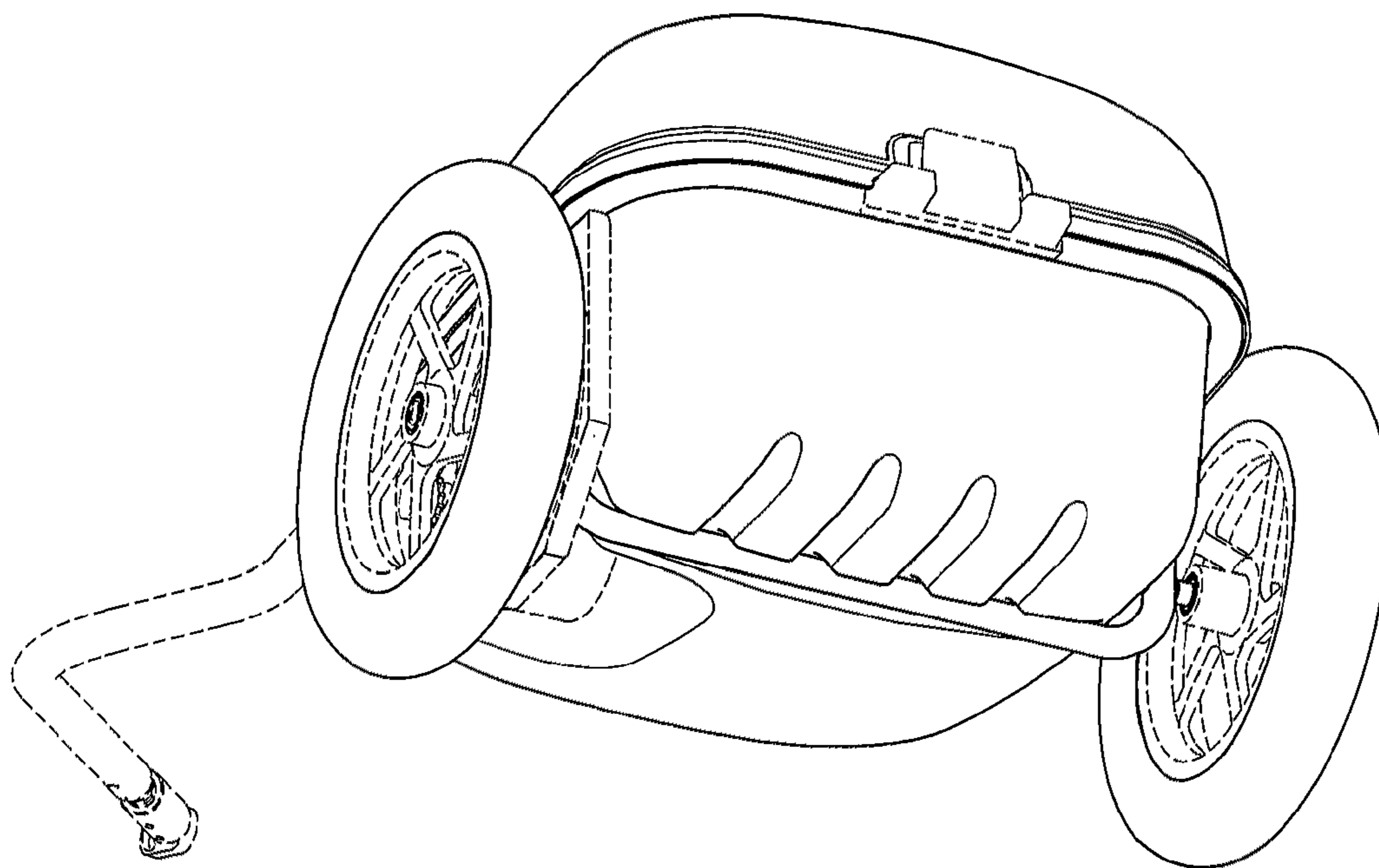

Fig. 8