



US00D663385S

(12) **United States Design Patent**  
**Marquis-Martin**

(10) **Patent No.:** **US D663,385 S**  
(45) **Date of Patent:** **\*\* Jul. 10, 2012**

(54) **FLOW CONTROL DEVICE**

(75) Inventor: **Guillaume Hugo Marquis-Martin**,  
Montreal (CA)

(73) Assignee: **IPEX Technologies Inc.**, Mississauga,  
Ontario

(\*\*) Term: **14 Years**

(21) Appl. No.: **29/404,570**

(22) Filed: **Oct. 21, 2011**

(51) **LOC (9) Cl.** ..... **23-01**

(52) **U.S. Cl.** ..... **D23/259**

(58) **Field of Classification Search** ..... D23/259-262;  
D8/353-354; 417/360; 137/810, 812-813,  
137/315.11

See application file for complete search history.

5,337,789	A *	8/1994	Cook	137/812
D407,467	S *	3/1999	McWilliams	D23/260
5,913,334	A *	6/1999	Hyun	137/810
D428,114	S *	7/2000	Le Bars	D23/233
6,374,858	B1 *	4/2002	Hides et al.	137/813
6,681,418	B1 *	1/2004	Bierend et al.	4/661
6,957,451	B2 *	10/2005	Brennan et al.	4/541.1
7,171,981	B2 *	2/2007	Shade et al.	137/533.11
D635,644	S *	4/2011	Yamada	D23/233
D639,392	S *	6/2011	Yamada	D23/233
D652,116	S *	1/2012	Fukushima	D23/235
2006/0000511	A1 *	1/2006	Shade et al.	137/533.11
2011/0285126	A1 *	11/2011	Jahan	285/305

\* cited by examiner

Primary Examiner — Eric Goodman

(74) Attorney, Agent, or Firm — K&L Gates LLP

(57) **CLAIM**

The ornamental design for a flow control device, as shown and described.

(56) **References Cited**

U.S. PATENT DOCUMENTS

D51,062	S *	7/1917	Goetz	D23/261
D52,040	S *	5/1918	Goetz	D23/261
2,603,451	A *	7/1952	Brown	251/364
3,195,303	A *	7/1965	Widell	60/231
3,207,168	A *	9/1965	Warren	137/809
3,215,165	A *	11/1965	Boadway	138/46
3,576,199	A *	4/1971	Schoepe et al.	137/414
3,666,015	A *	5/1972	Livingston	169/5
3,670,962	A *	6/1972	Johnston	239/62
3,941,350	A *	3/1976	Kluczynski	251/127
4,317,473	A *	3/1982	Gaydos	138/45
4,846,224	A *	7/1989	Collins et al.	137/810
5,080,137	A *	1/1992	Adams	137/810

**DESCRIPTION**

FIG. 1 is a right perspective view of a flow control device showing my new design;  
FIG. 2 is a front view thereof;  
FIG. 3 is a back view thereof;  
FIG. 4 is a left side view thereof;  
FIG. 5 is a right side view thereof;  
FIG. 6 is a top view thereof; and,  
FIG. 7 is a bottom view thereof.  
The broken line portions in the drawings are for illustrative purposes and do not form a part of the claimed design.

**1 Claim, 7 Drawing Sheets**

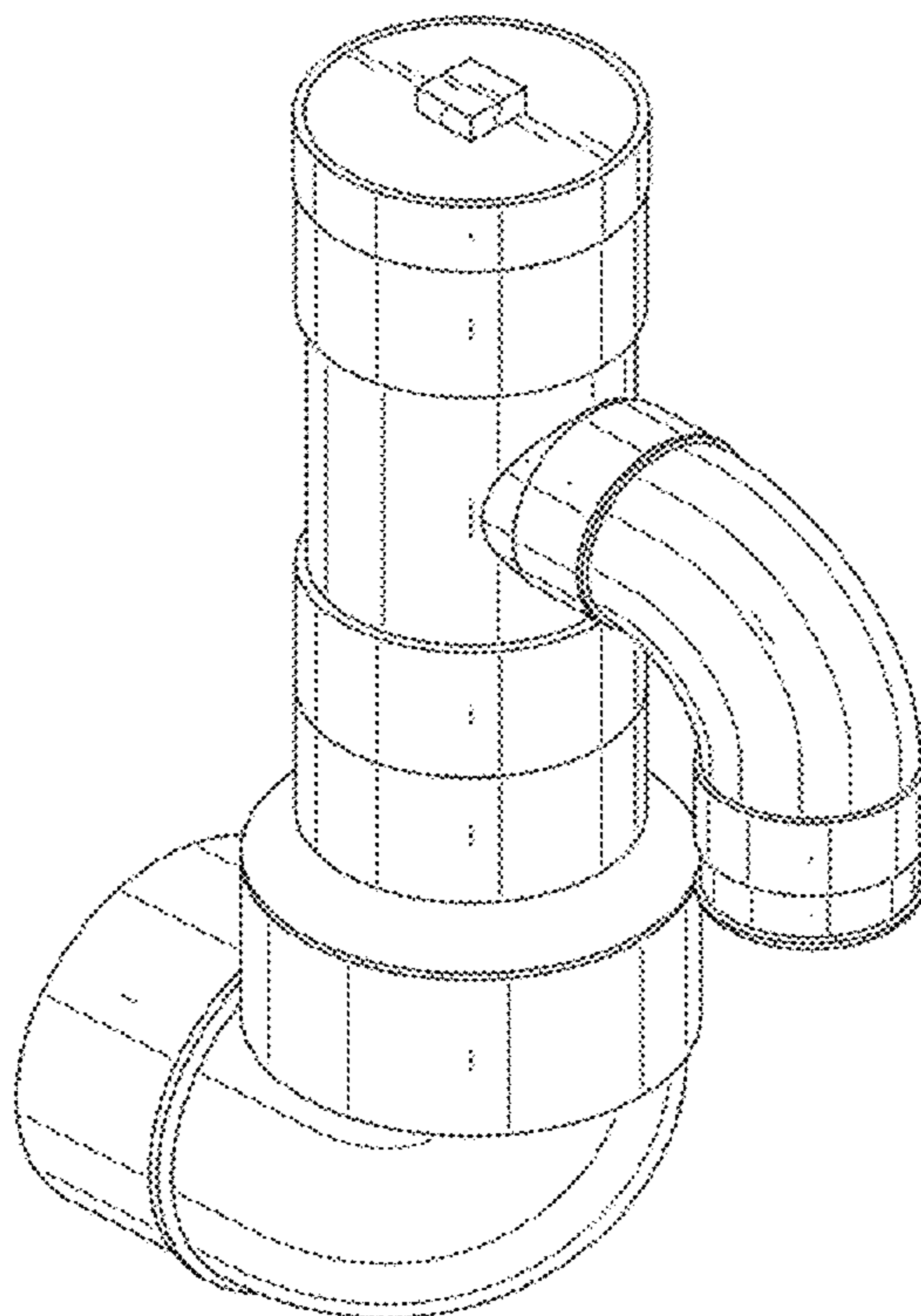

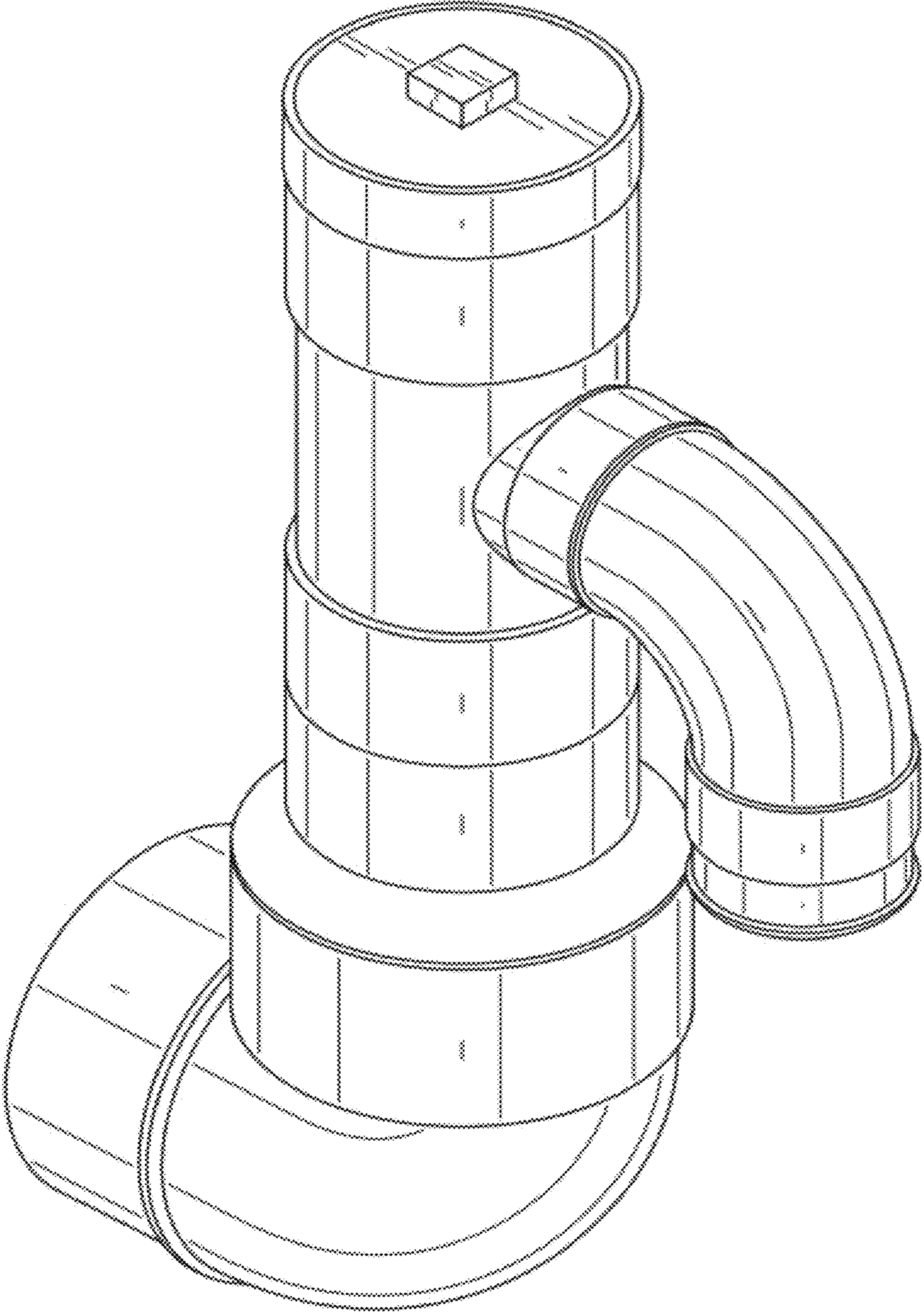

FIG. 1

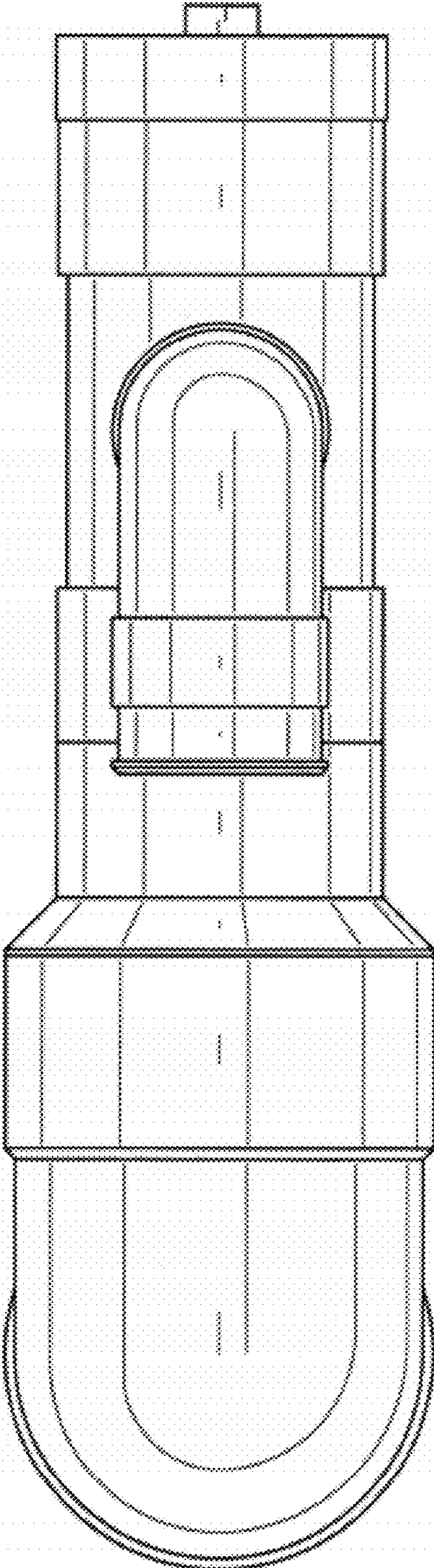

FIG. 2

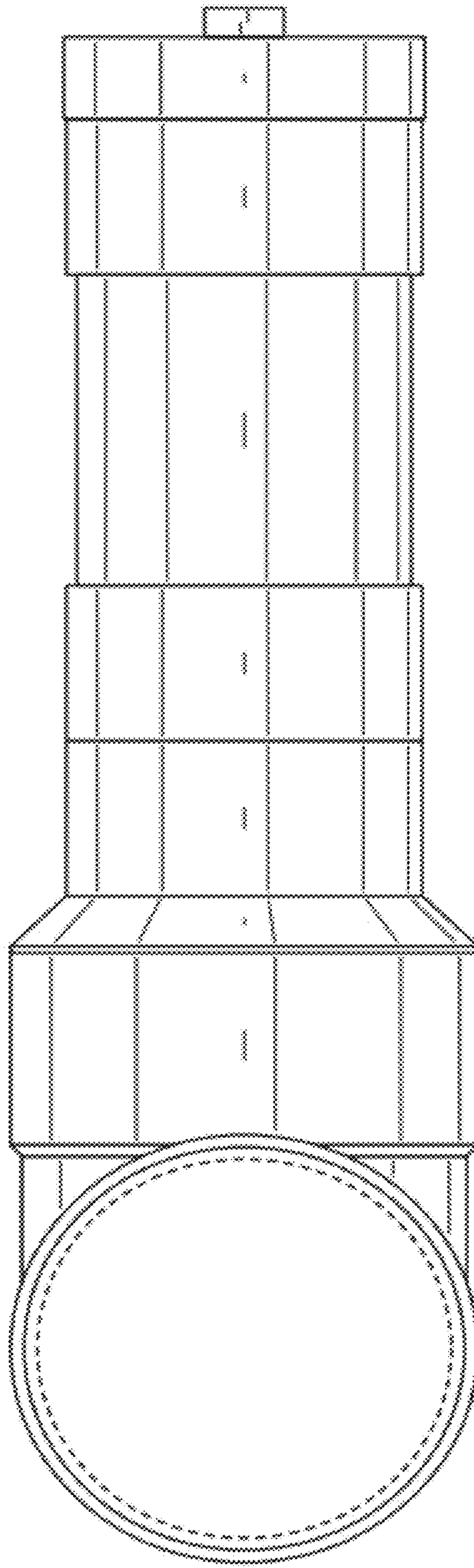

FIG. 3

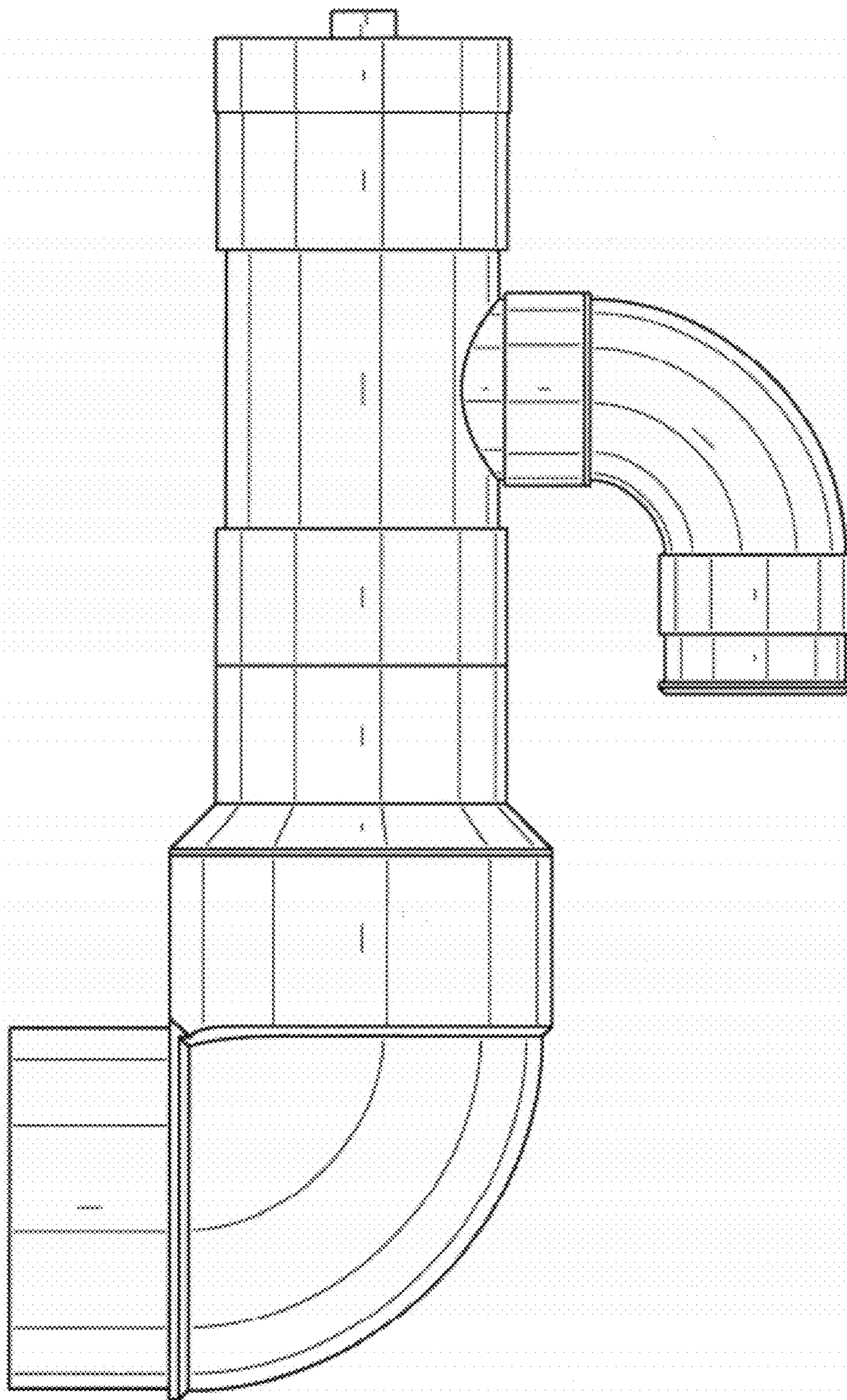

FIG. 4

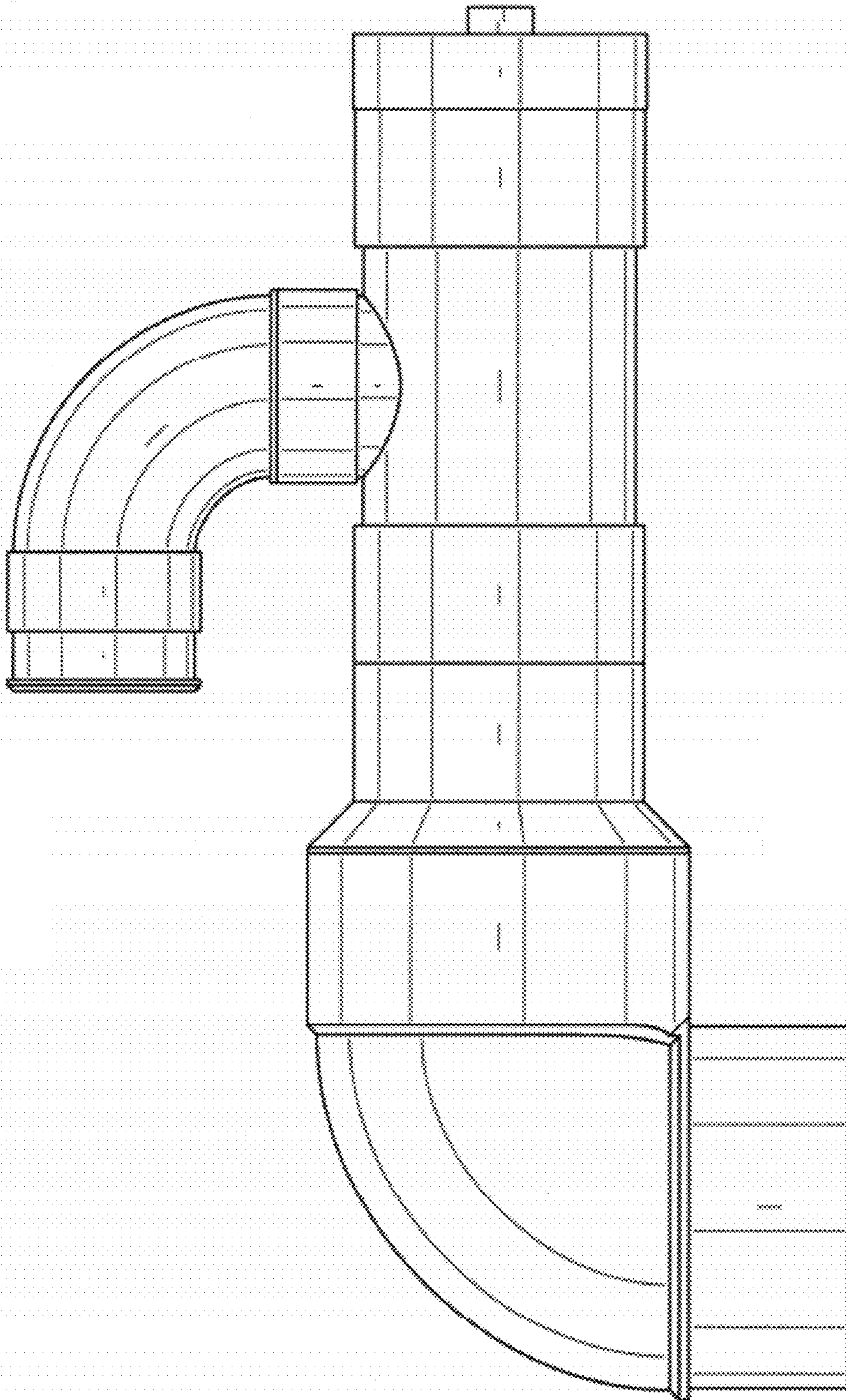

FIG. 5

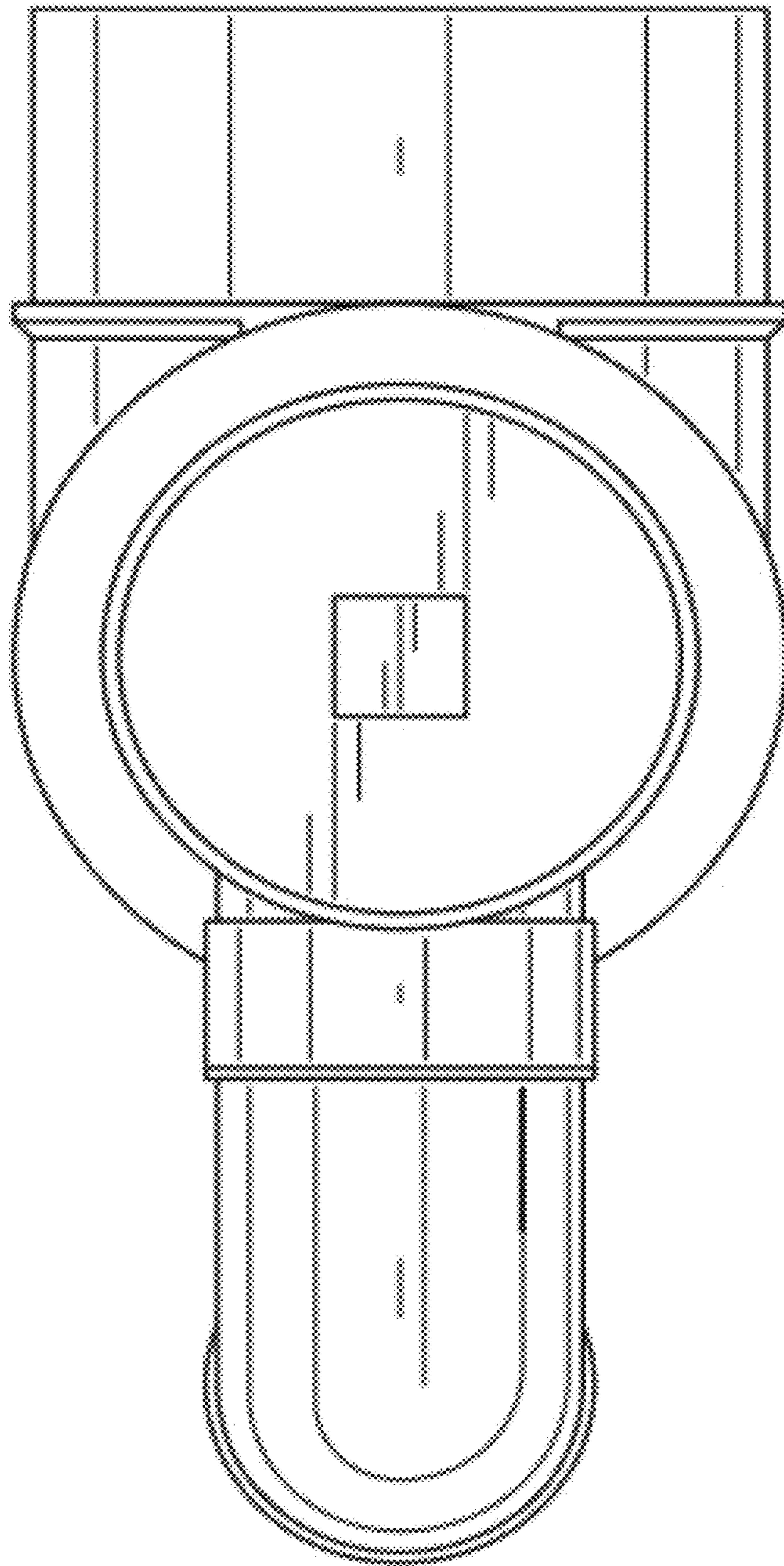

FIG. 6

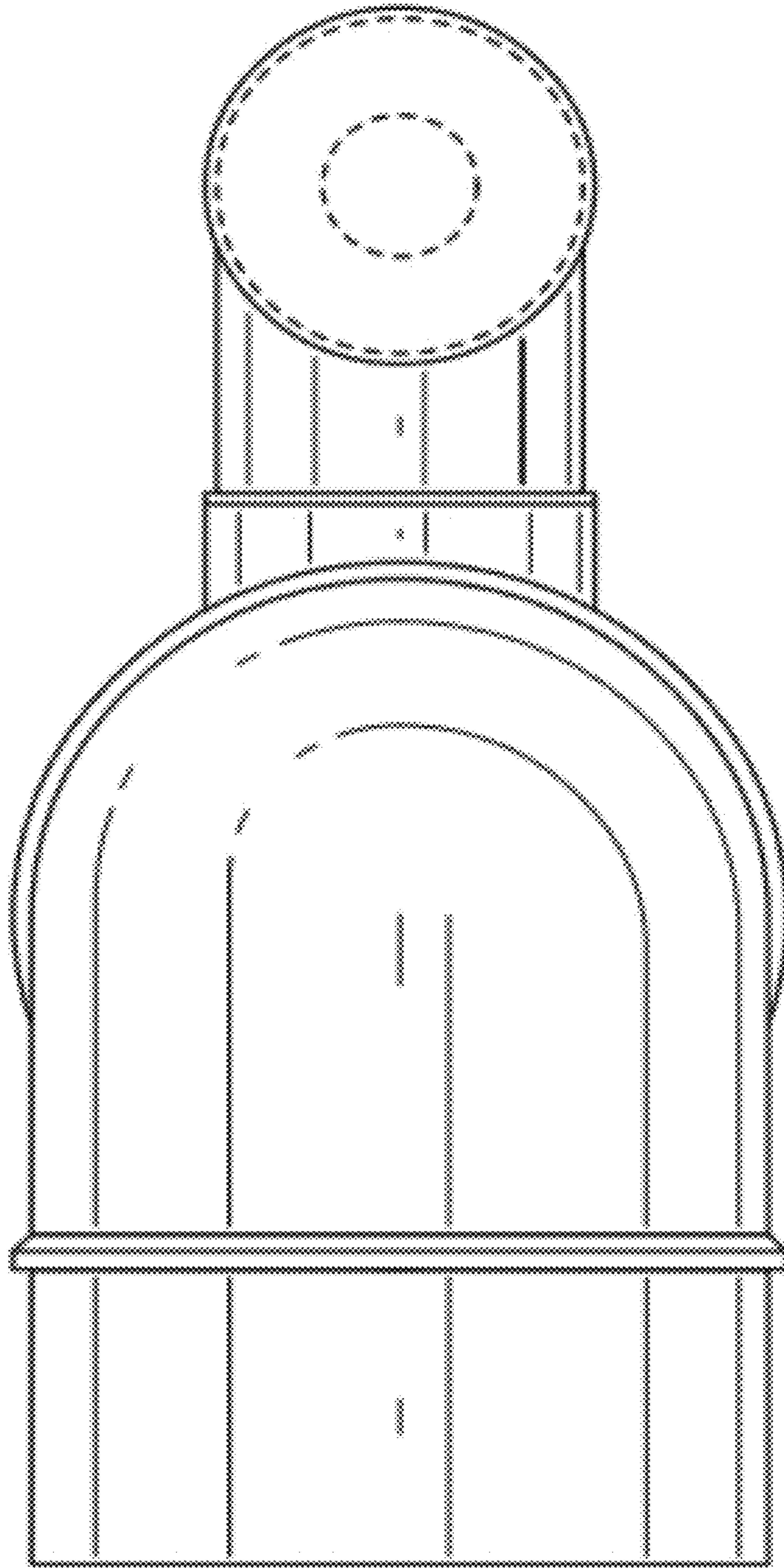

FIG. 7