



US00D663324S

(12) **United States Design Patent**  
**Fuchita et al.**

(10) **Patent No.:** **US D663,324 S**  
(45) **Date of Patent:** **\*\* Jul. 10, 2012**

(54) **EXCAVATOR**

(75) Inventors: **Seiichi Fuchita**, Hirakata (JP); **Yuuji Shiomoto**, Hirakata (JP); **Junsei Tanaka**, Hirakata (JP); **Tomoya Kumagai**, Tokyo (JP)

(73) Assignee: **Komatsu Ltd.**, Tokyo (JP)

(\*\*) Term: **14 Years**

(21) Appl. No.: **29/371,538**

(22) Filed: **Apr. 11, 2011**

(30) **Foreign Application Priority Data**

Dec. 24, 2010 (JP) ..... 2010-030865

(51) **LOC (9) Cl.** ..... **12-09**

(52) **U.S. Cl.** ..... **D15/25**

(58) **Field of Classification Search** ..... D15/10,  
D15/22-26; 37/403, 411, 443; 414/685,  
414/686, 688, 722-724; 180/89.13

See application file for complete search history.

(56) **References Cited**

**U.S. PATENT DOCUMENTS**

4,397,481 A \* 8/1983 Dion et al. .... 280/781  
D271,396 S \* 11/1983 Inui ..... D15/24

5,544,435 A \* 8/1996 Somero ..... 37/405  
5,590,482 A \* 1/1997 Peterson et al. .... 37/403  
D391,272 S \* 2/1998 Jin et al. .... D15/25  
D409,629 S \* 5/1999 Miyaoka et al. .... D15/25  
D437,602 S \* 2/2001 Hiraoka et al. .... D15/25  
D460,975 S \* 7/2002 Yanagida et al. .... D15/25  
D462,973 S \* 9/2002 Tamaru et al. .... D15/25  
D462,974 S \* 9/2002 Yanagida et al. .... D15/25  
D534,552 S \* 1/2007 Yanagida ..... D15/25

**FOREIGN PATENT DOCUMENTS**

JP HN13015886 10/2001

\* cited by examiner

*Primary Examiner* — Mark Goodwin

(74) *Attorney, Agent, or Firm* — Manabu Kanesaka

(57) **CLAIM**

The ornamental design for an excavator, as shown and described.

**DESCRIPTION**

FIG. 1 is a front view of an excavator showing our new design;

FIG. 2 is rear view thereof;

FIG. 3 is a top plan view thereof.

FIG. 4 is a bottom plan view thereof.

FIG. 5 is a left side view thereof; and,

FIG. 6 is a right side view thereof.

**1 Claim, 5 Drawing Sheets**

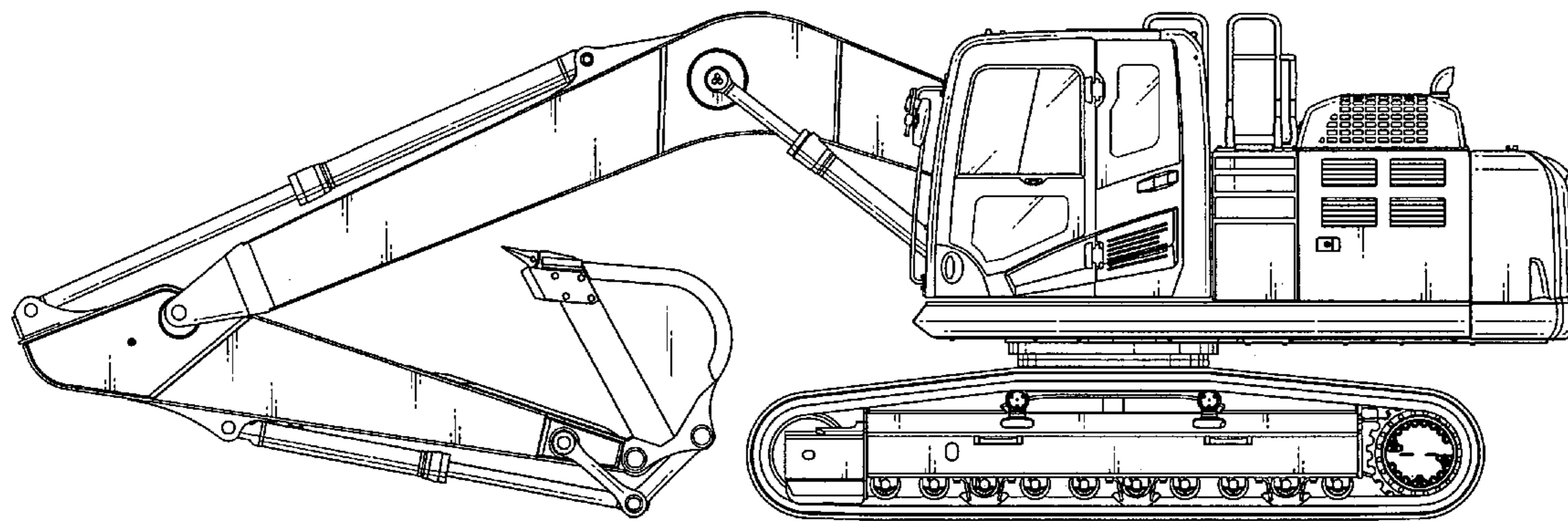

Fig. 1

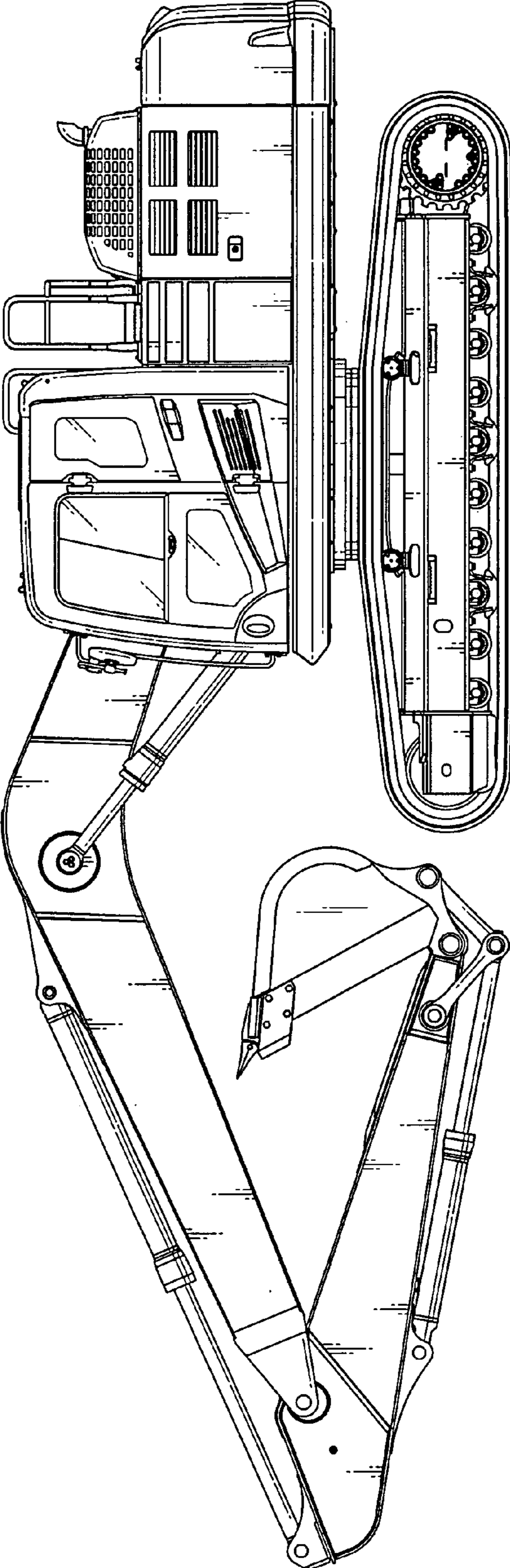
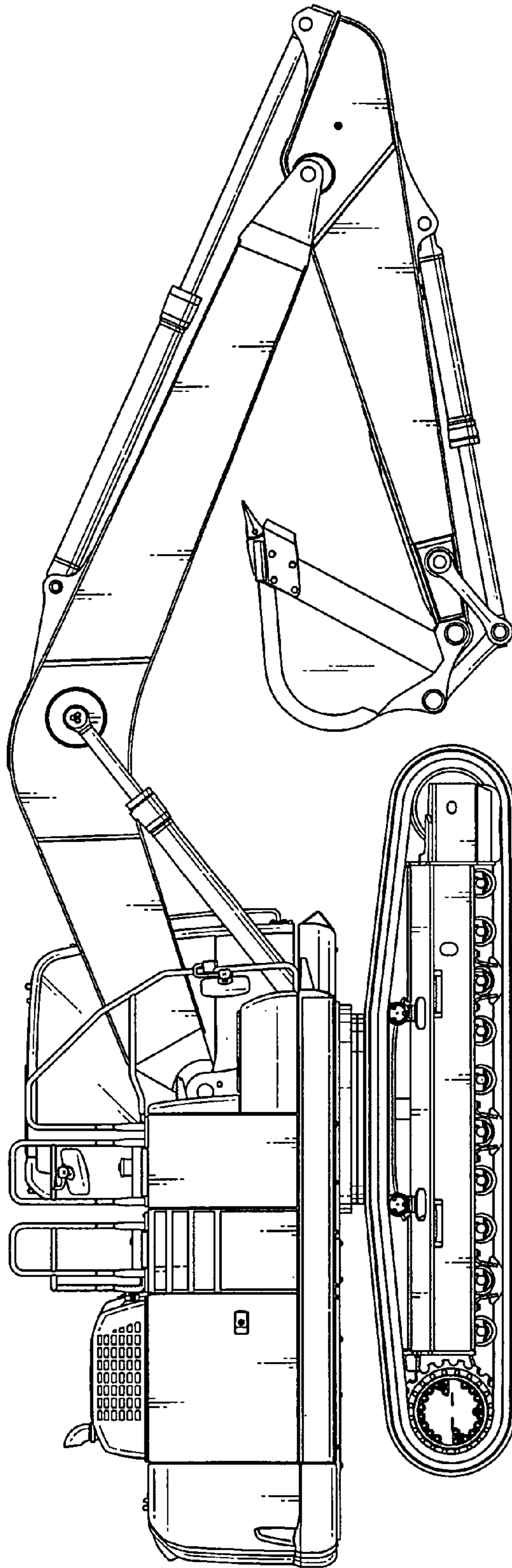

Fig. 2



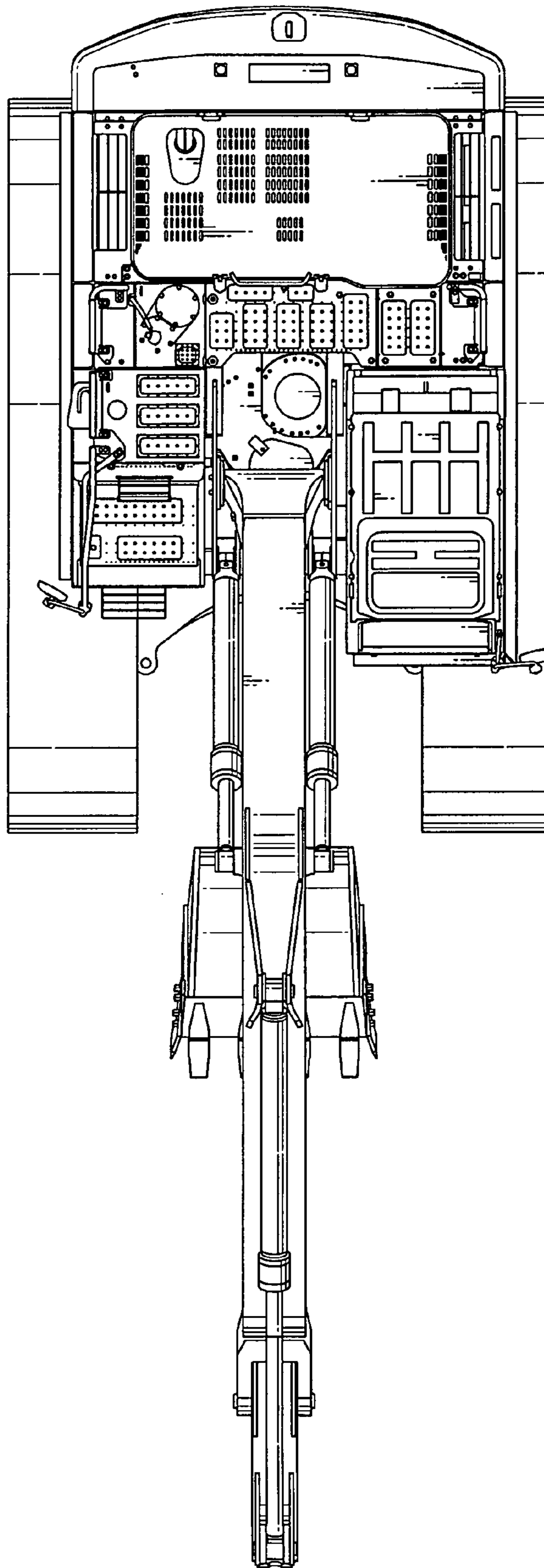

Fig. 3

Fig. 4

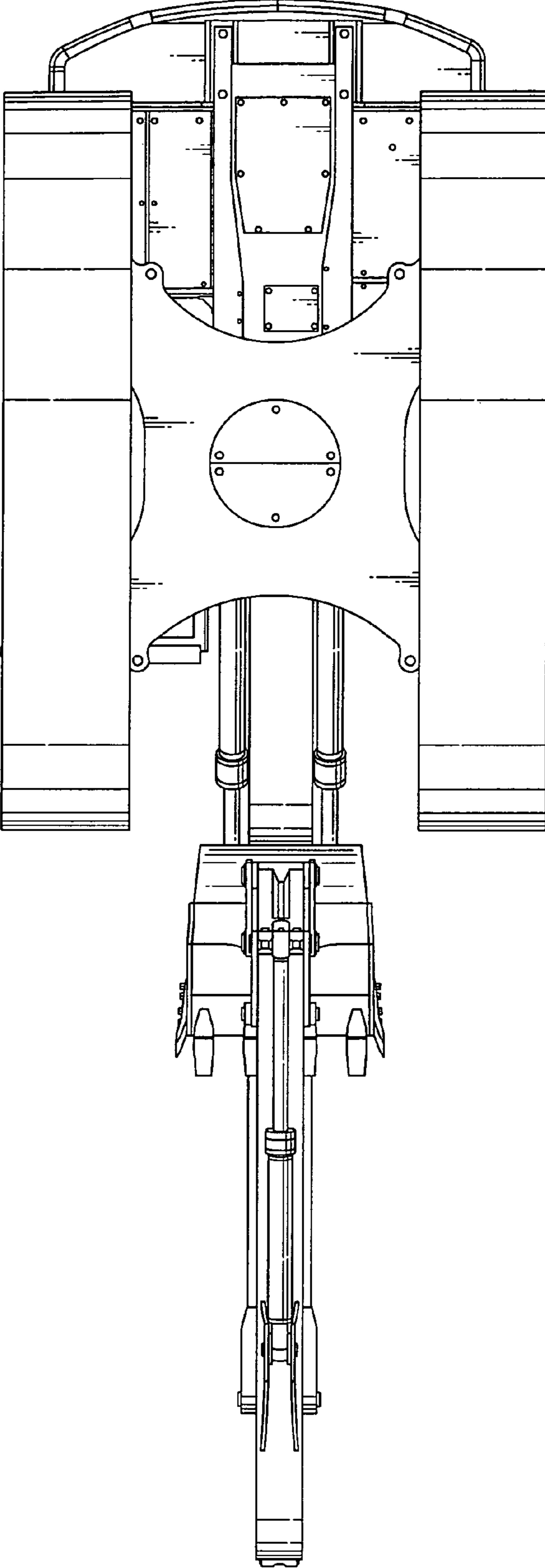

Fig. 6

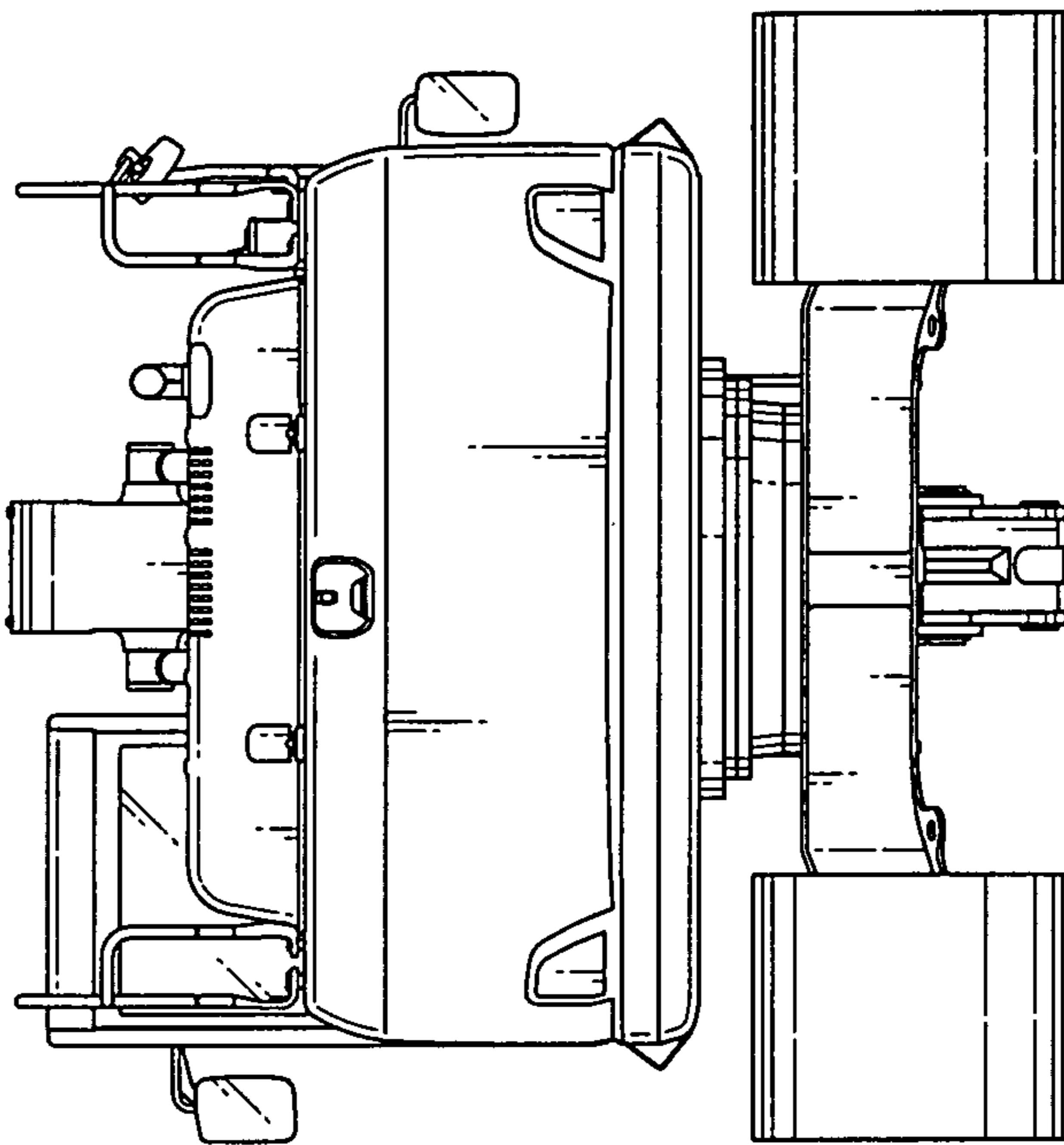

Fig. 5

