

US00D663252S

(12) **United States Design Patent**
Bondesson

(10) **Patent No.:** **US D663,252 S**
(45) **Date of Patent:** **** Jul. 10, 2012**

(54) **CONTROL LEVER FOR A MARINE VESSEL**

(75) Inventor: **Anders Bondesson**, Billdal (SE)

(73) Assignee: **AB Volvo Penta**, Gothenburg (SE)

(**) Term: **14 Years**

(21) Appl. No.: **29/367,007**

(22) Filed: **Aug. 2, 2010**

(30) **Foreign Application Priority Data**

Feb. 5, 2010 (EM) 001193924-0004

(51) **LOC (9) Cl.** **12-06**

(52) **U.S. Cl.** **D12/317**

(58) **Field of Classification Search** D12/300,
D12/301, 303-315, 317, 318, 174, 178-180;
D13/162, 134, 168, 169, 173; D10/49; 74/469,
74/473.19, 473.2, 480 B, 491; 440/84-87;
477/98, 111, 112, 113

See application file for complete search history.

(56) **References Cited**

U.S. PATENT DOCUMENTS

4,090,598 A * 5/1978 Prince 477/113
4,222,474 A * 9/1980 Choudhury et al. 477/112
4,253,349 A * 3/1981 Floeter et al. 477/113
5,062,516 A * 11/1991 Prince 477/98
D497,347 S * 10/2004 Iekura D13/168
D510,311 S * 10/2005 Rick et al. D12/317

D510,556 S * 10/2005 Rick et al. D12/317
D510,557 S * 10/2005 Rick et al. D12/317
D510,558 S * 10/2005 Rick et al. D12/317
6,979,278 B2 * 12/2005 Rick et al. 477/98
RE39,032 E * 3/2006 Gonring et al. 440/87
7,172,478 B2 * 2/2007 Blair et al. 440/87
D546,268 S * 7/2007 Ongaro D12/317
D581,855 S 12/2008 Arol
D592,605 S * 5/2009 Iekura D13/168
D623,043 S * 9/2010 Riddiford D8/349
8,128,443 B2 * 3/2012 Gai et al. 440/86
2005/0245147 A1 * 11/2005 Takada et al. 440/84

* cited by examiner

Primary Examiner — Cynthia M Chin

(74) *Attorney, Agent, or Firm* — Martin Farrell; Michael Pruden

(57) **CLAIM**

The ornamental design for a control lever for a marine vessel, as shown and described.

DESCRIPTION

FIG. 1 is a perspective view from the front showing the new design;

FIG. 2 is a side view from the right side thereof;

FIG. 3 is a side view from the left side thereof;

FIG. 4 is a front view thereof;

FIG. 5 is a rear view thereof;

FIG. 6 is a top view thereof; and,

FIG. 7 is a bottom view thereof.

In the drawings, the broken lines depict environmental subject matter only and form no part of the claimed design.

1 Claim, 7 Drawing Sheets

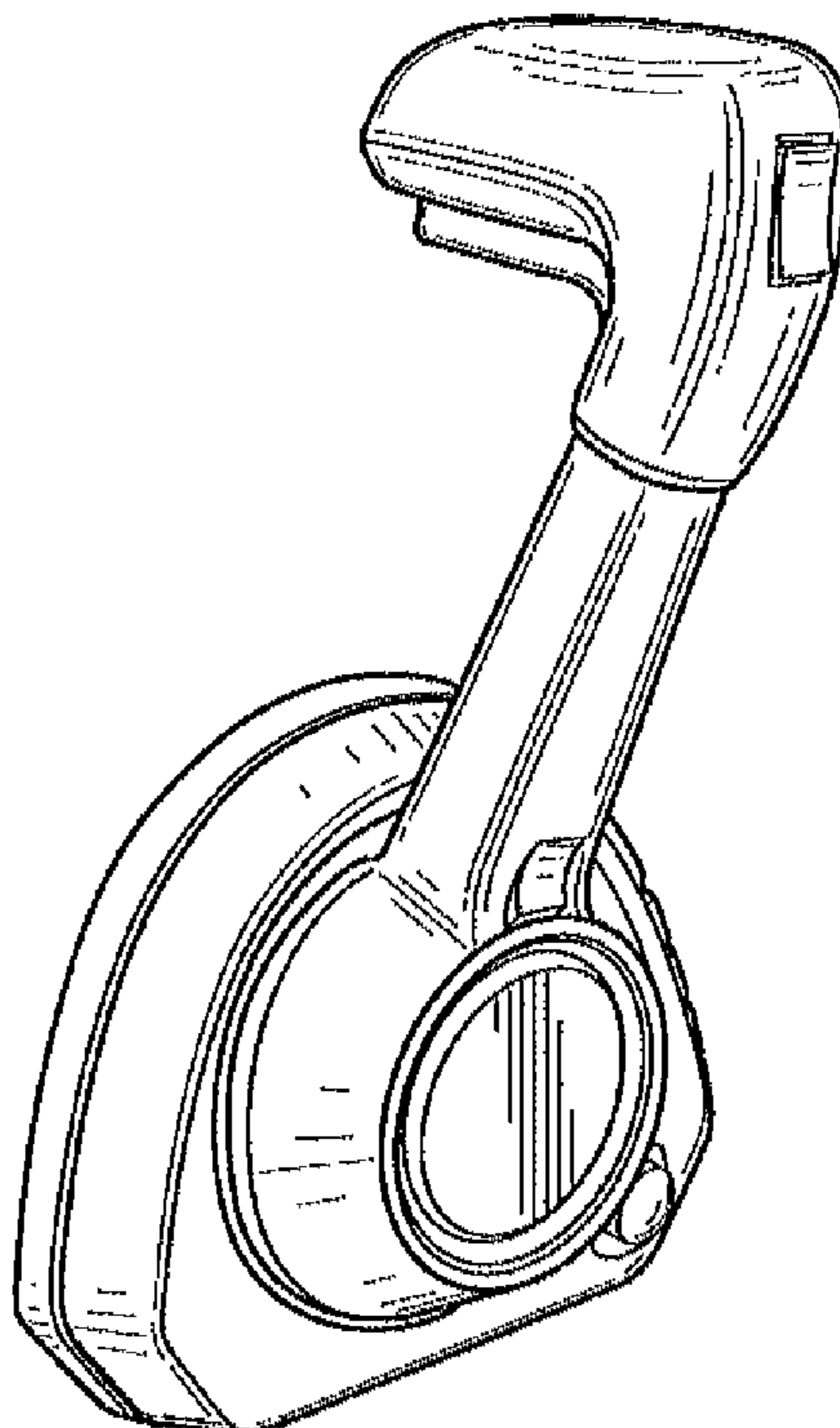

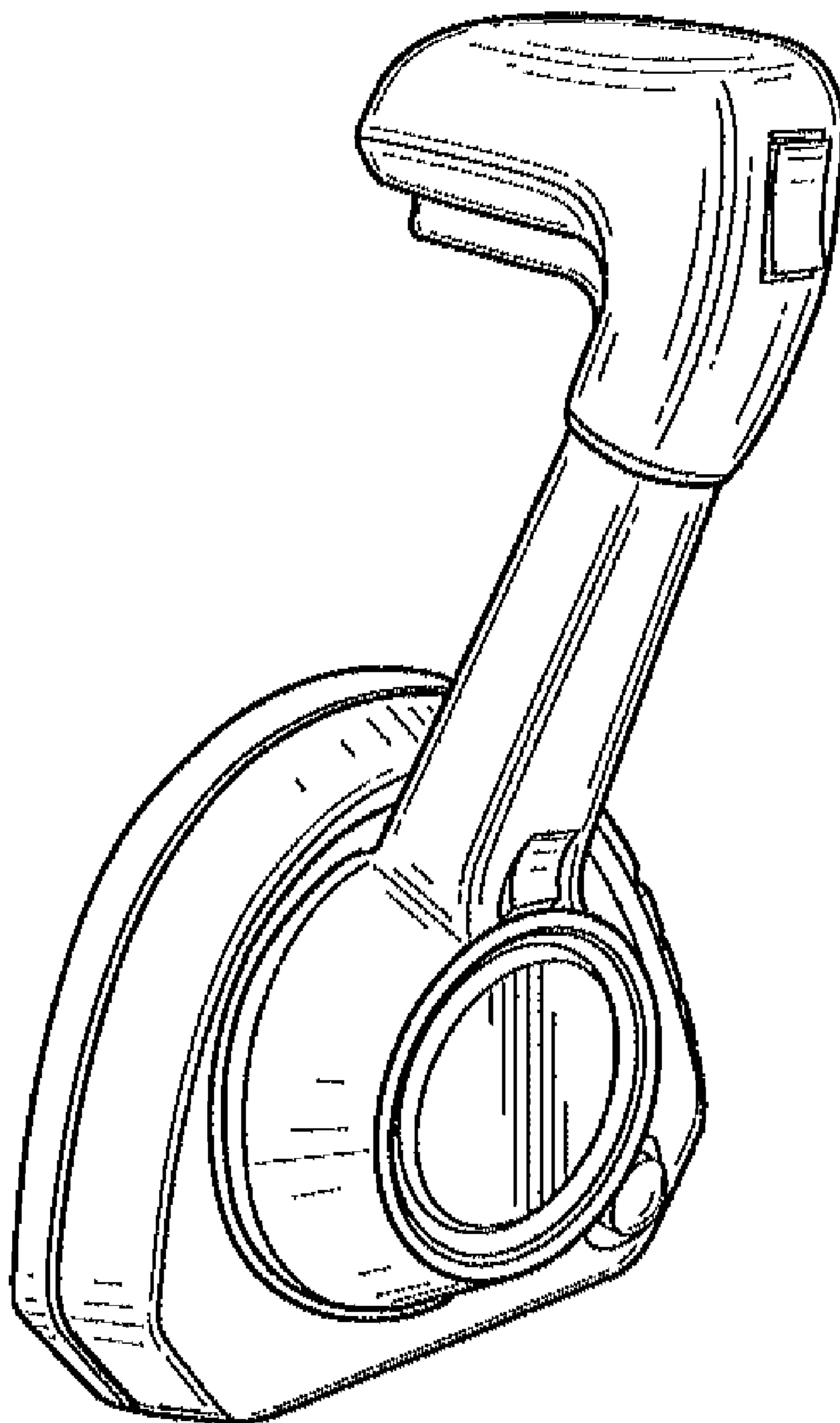

FIG. 1

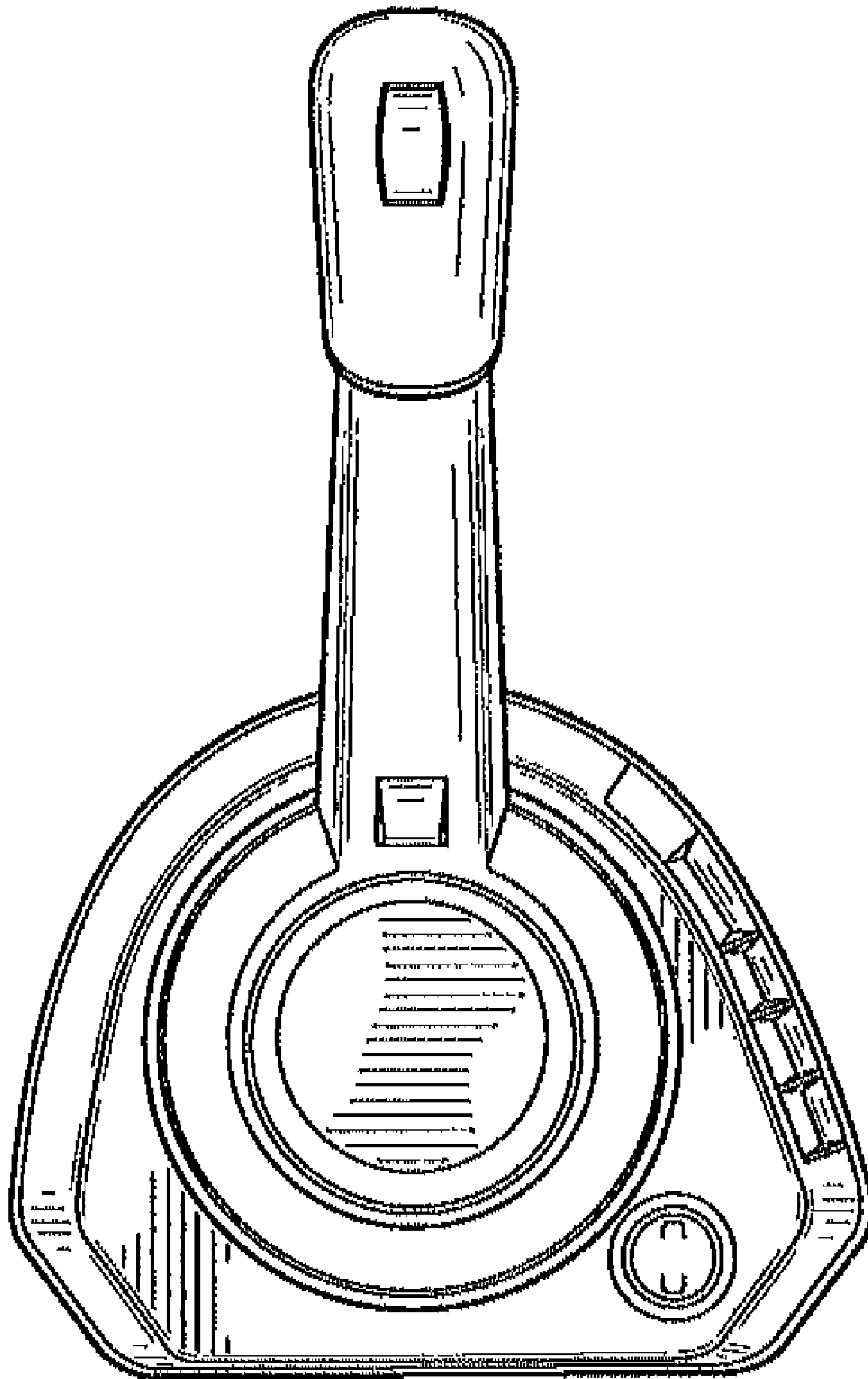

FIG. 2

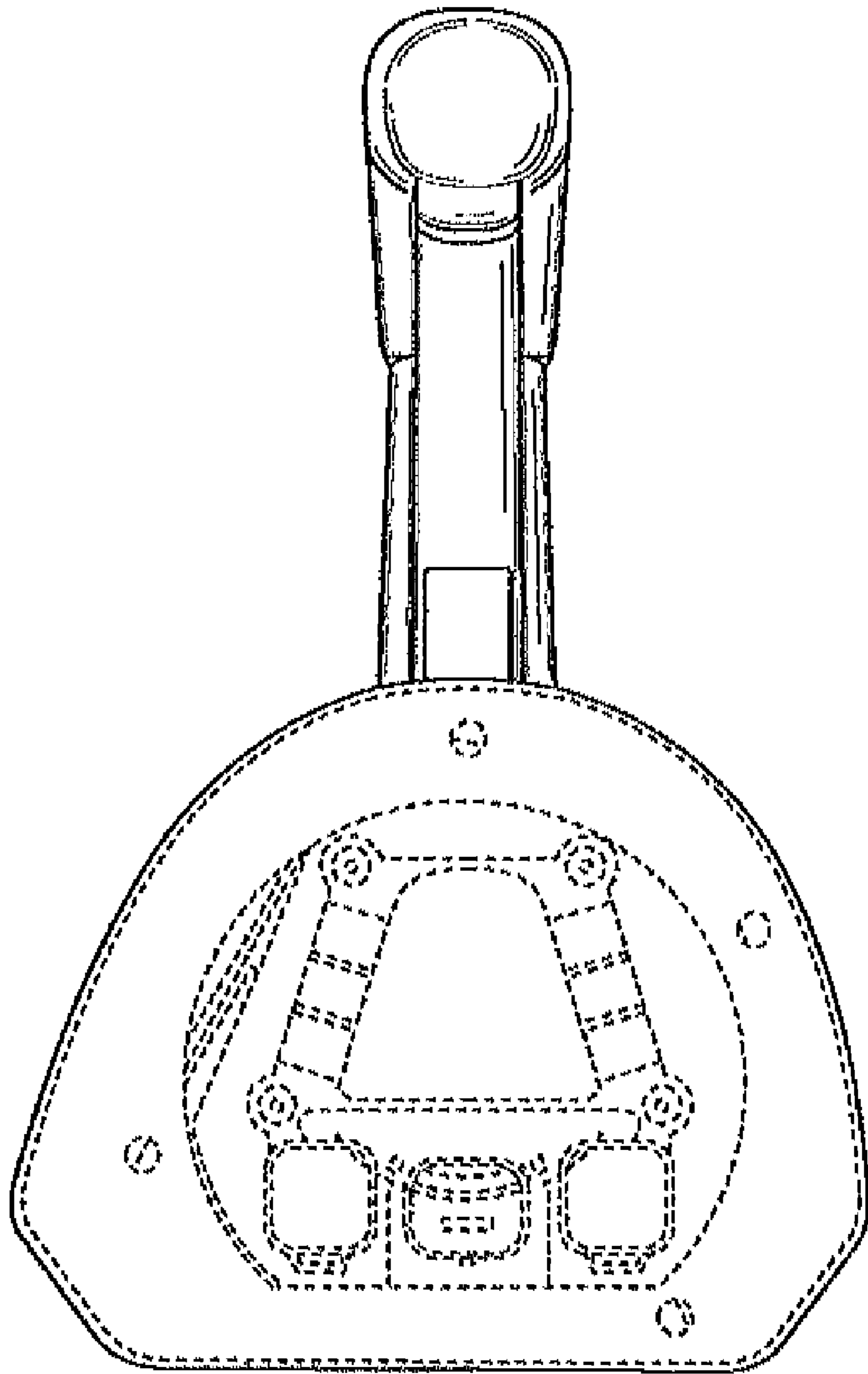

FIG. 3

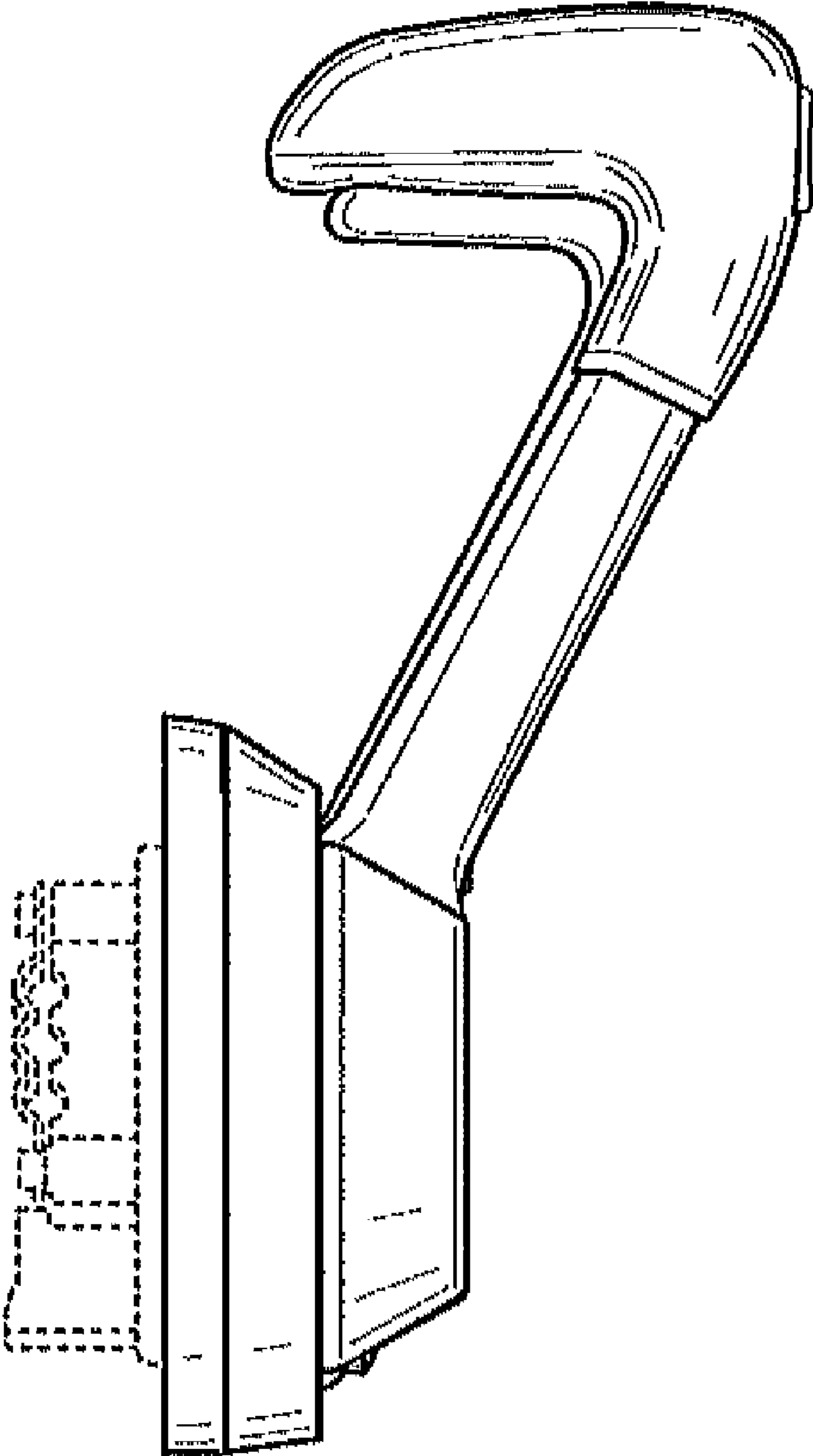

FIG. 4

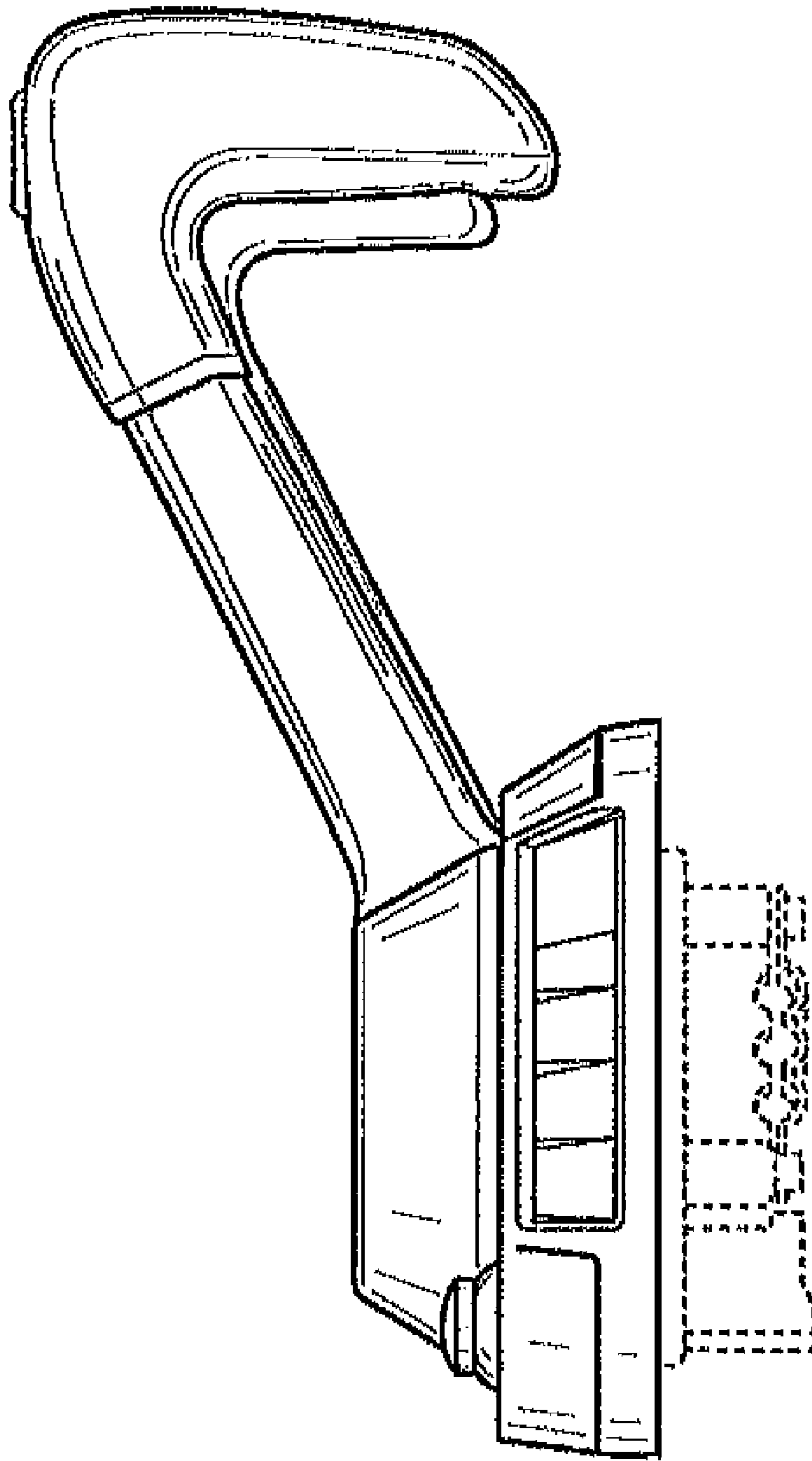

FIG. 5

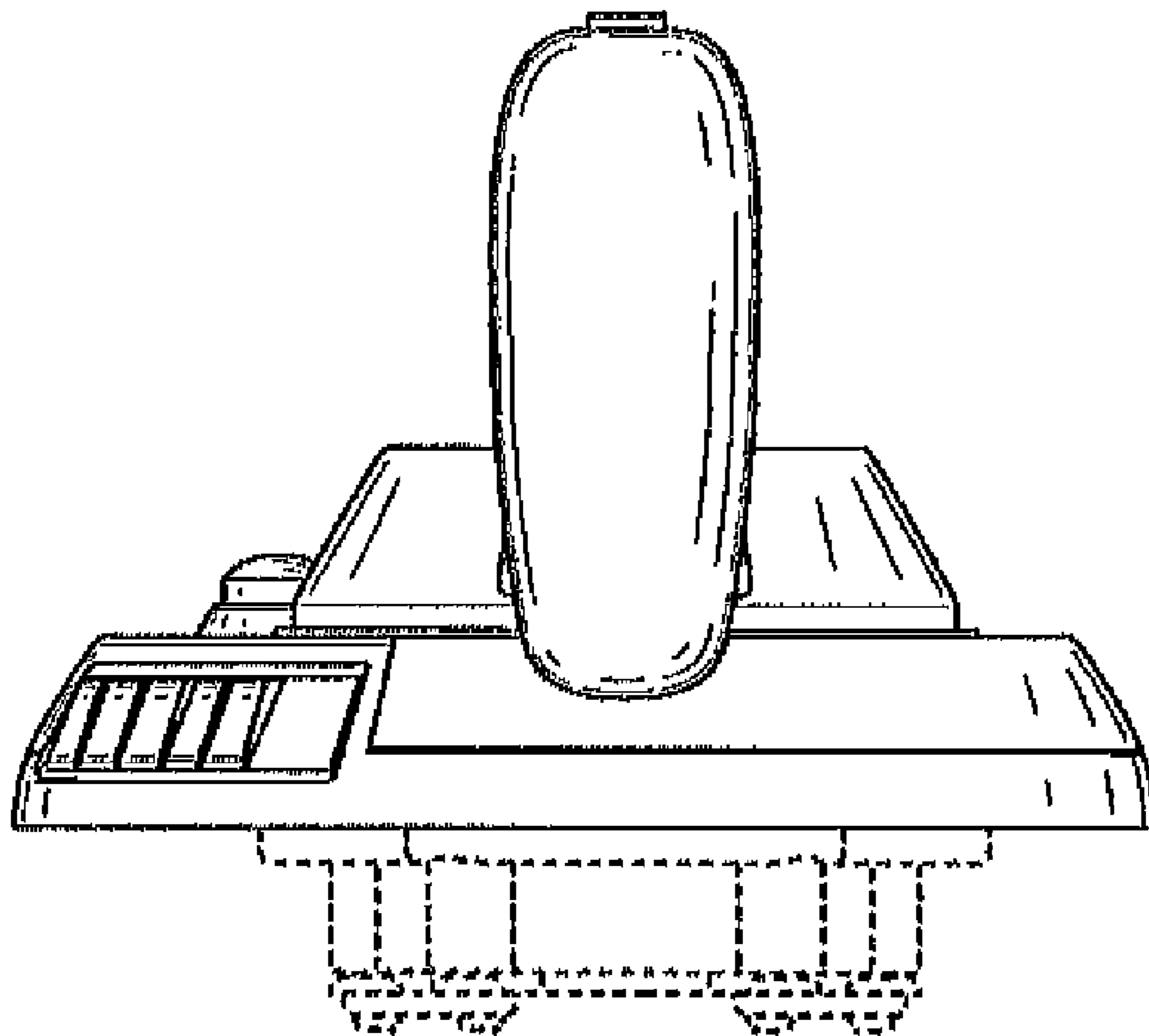

FIG. 6

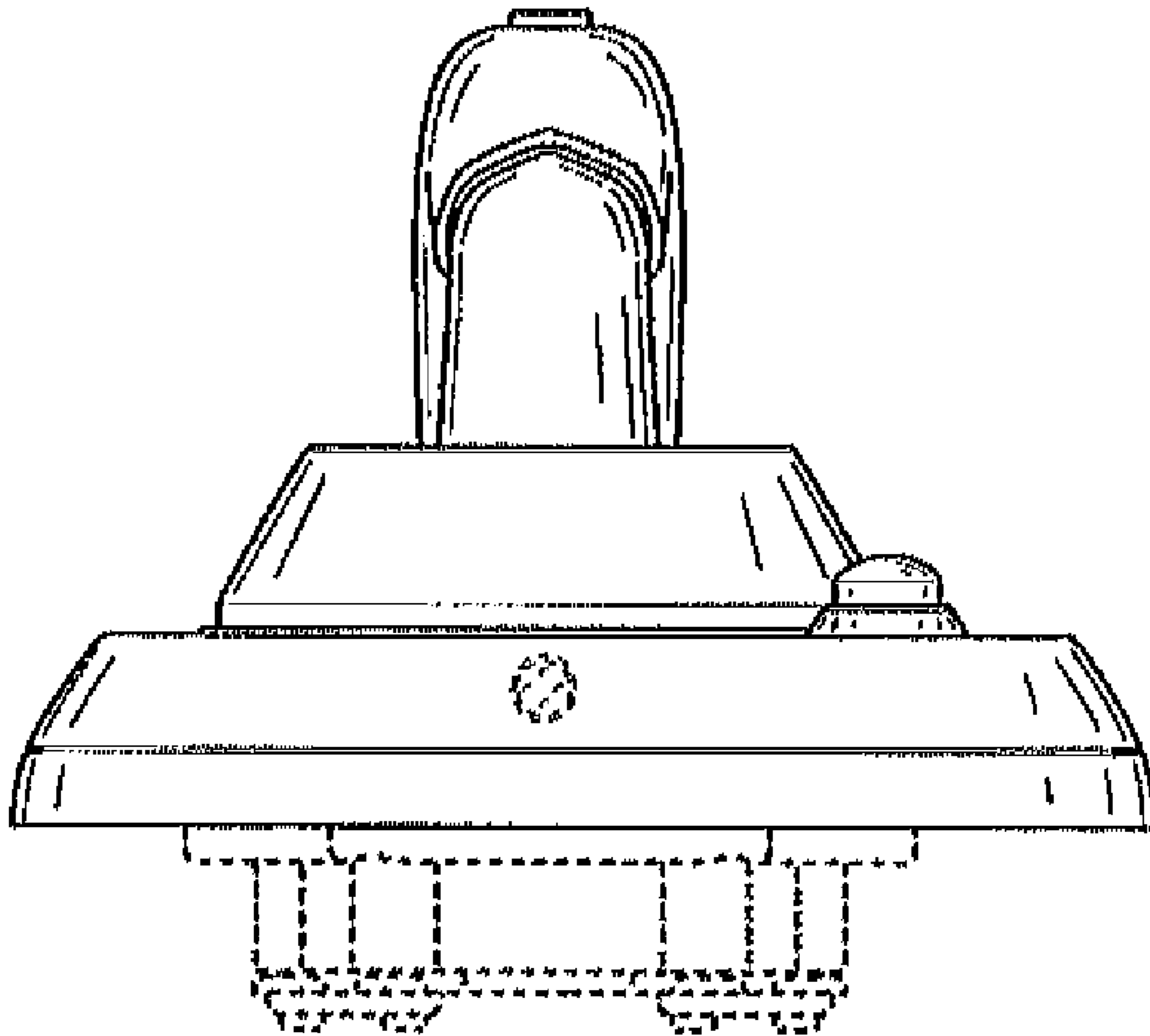

FIG. 7