



US00D663035S

(12) **United States Design Patent**  
**Smith**

(10) **Patent No.:** **US D663,035 S**  
(45) **Date of Patent:** **\*\* Jul. 3, 2012**

(54) **TWO-PORT IMPLANTABLE MEDICAL DEVICE**

(75) Inventor: **Alexander K. Smith**, Chesterland, OH (US)

(73) Assignee: **Greatbatch Ltd.**, Clarence, NY (US)

(\*\*) Term: **14 Years**

(21) Appl. No.: **29/403,072**

(22) Filed: **Sep. 30, 2011**

(51) **LOC (9) Cl.** ..... **24-03**

(52) **U.S. Cl.** ..... **D24/187; D24/167**

(58) **Field of Classification Search** ..... D24/144, D24/158, 164, 167, 168, 170, 186-187, 200, D24/231, 155; 600/300, 301, 368, 372, 481, 600/529, 544, 554, 561; 607/2, 4, 5, 9, 30  
See application file for complete search history.

(56) **References Cited**

U.S. PATENT DOCUMENTS

D261,552 S *	10/1981	Boroda	.....	D24/200
D269,205 S *	5/1983	Langer et al.	.....	D24/167
D280,930 S *	10/1985	Speicher et al.	.....	D24/167
D337,820 S *	7/1993	Hooper et al.	.....	D24/155
D338,731 S *	8/1993	Byland et al.	.....	D24/167
D343,901 S *	2/1994	Anderson	.....	D24/167
D478,990 S *	8/2003	Kroll	.....	D24/167

D523,144 S *	6/2006	Wenger et al.	.....	D24/155
D559,987 S *	1/2008	Strother et al.	.....	D24/187
D598,552 S *	8/2009	Potts et al.	.....	D24/187
D598,553 S *	8/2009	Potts et al.	.....	D24/187
D599,910 S *	9/2009	Potts et al.	.....	D24/187
D610,261 S *	2/2010	Strother et al.	.....	D24/186
D613,868 S *	4/2010	Lhuillery et al.	.....	D24/187
2008/0208267 A1 *	8/2008	Alexander et al.	.....	607/2

\* cited by examiner

*Primary Examiner* — T. Chase Nelson

*Assistant Examiner* — Mark Cavanna

(74) *Attorney, Agent, or Firm* — Pearne & Gordon LLP

(57) **CLAIM**

The ornamental design for a two-port implantable medical device, as shown and described.

**DESCRIPTION**

FIG. 1 is a front perspective view of a two-port implantable medical device showing my new design; FIG. 2 is a front view thereof; FIG. 3 is a rear view thereof; FIG. 4 is a top view thereof; FIG. 5 is a bottom view thereof; FIG. 6 is a left side view thereof; and, FIG. 7 is a right side view thereof. The portions of my design shown in broken lines are provided for illustrative purposes only and form no part of the claimed design.

**1 Claim, 5 Drawing Sheets**

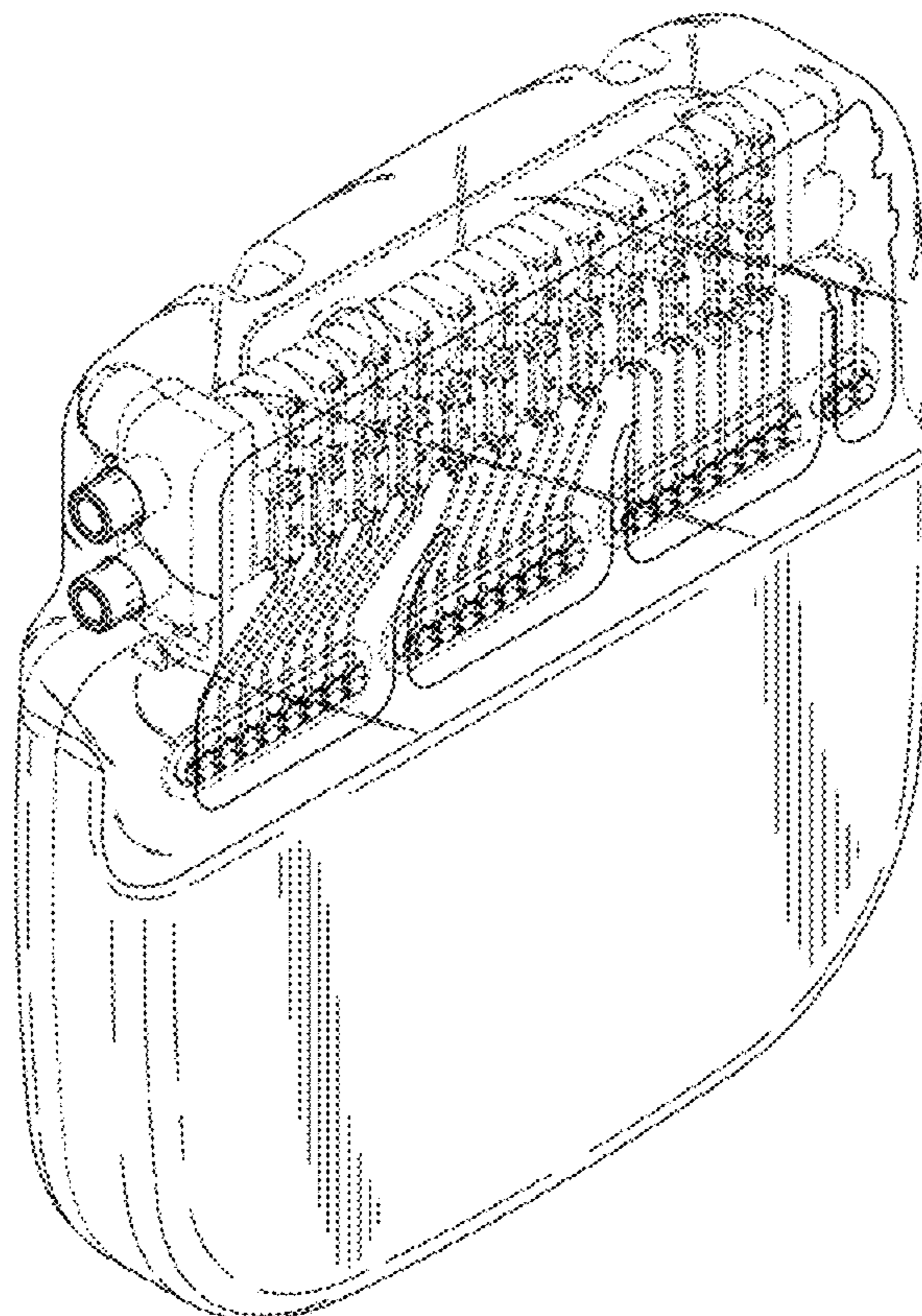

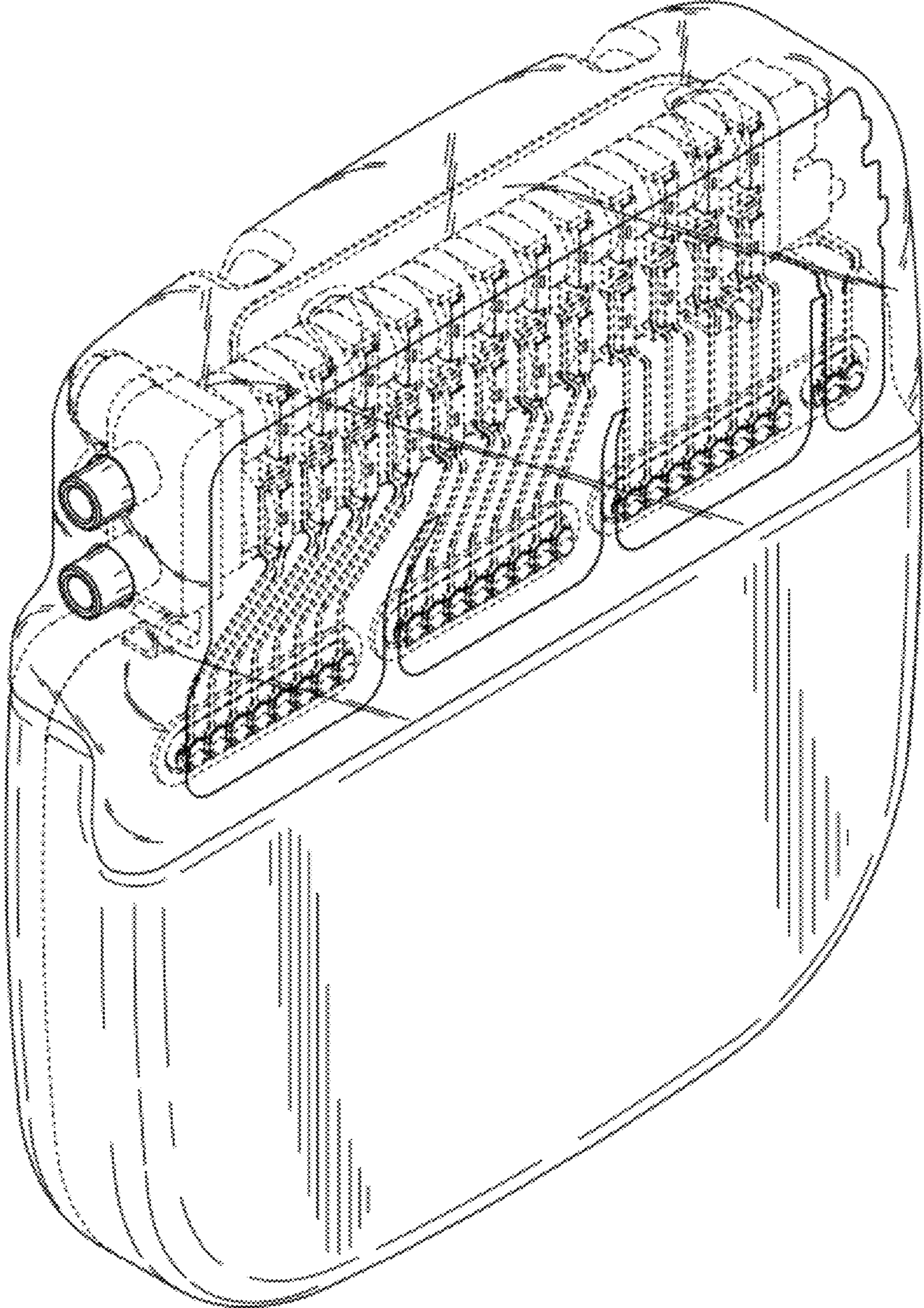

Fig. 1

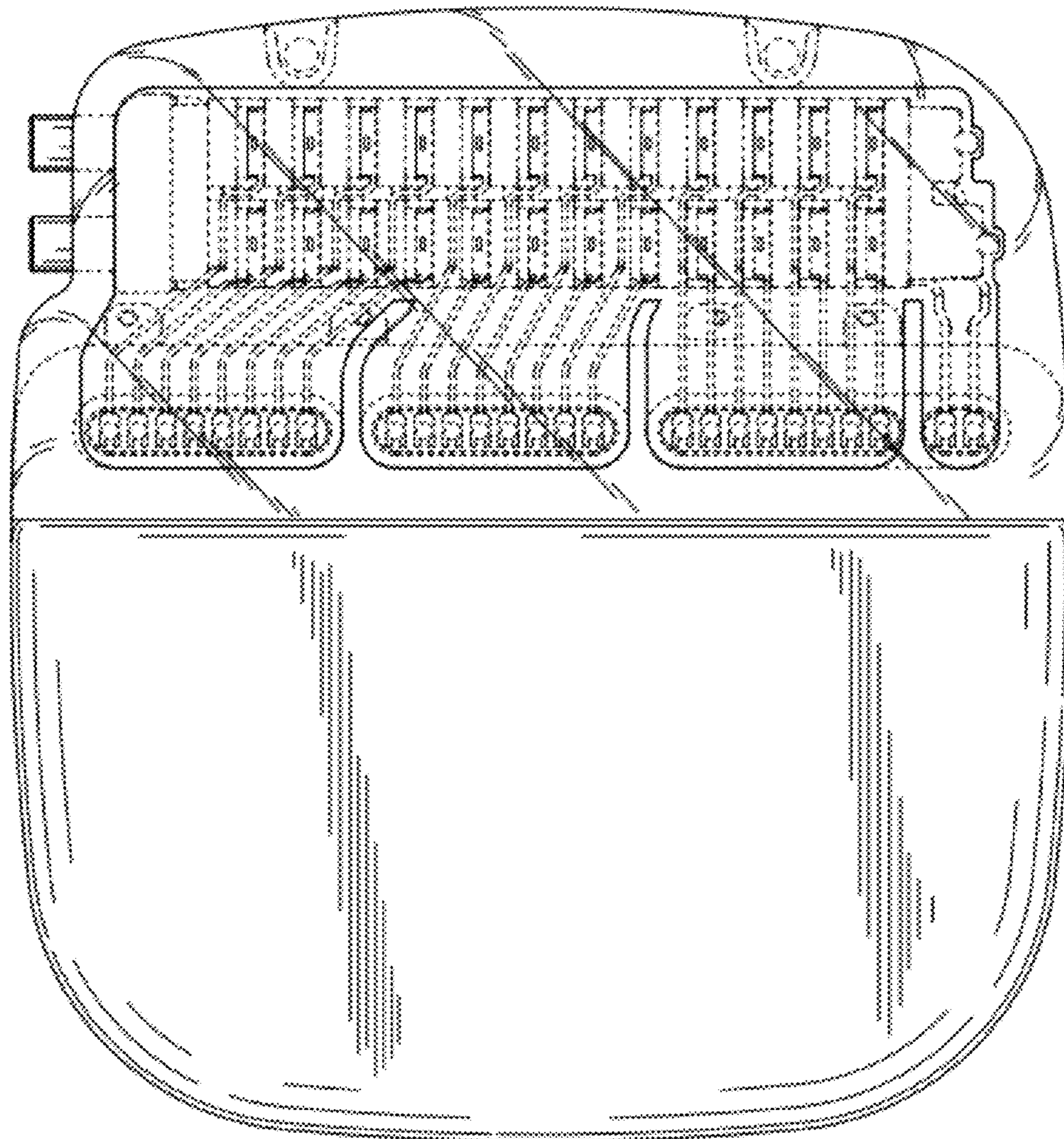

Fig. 2

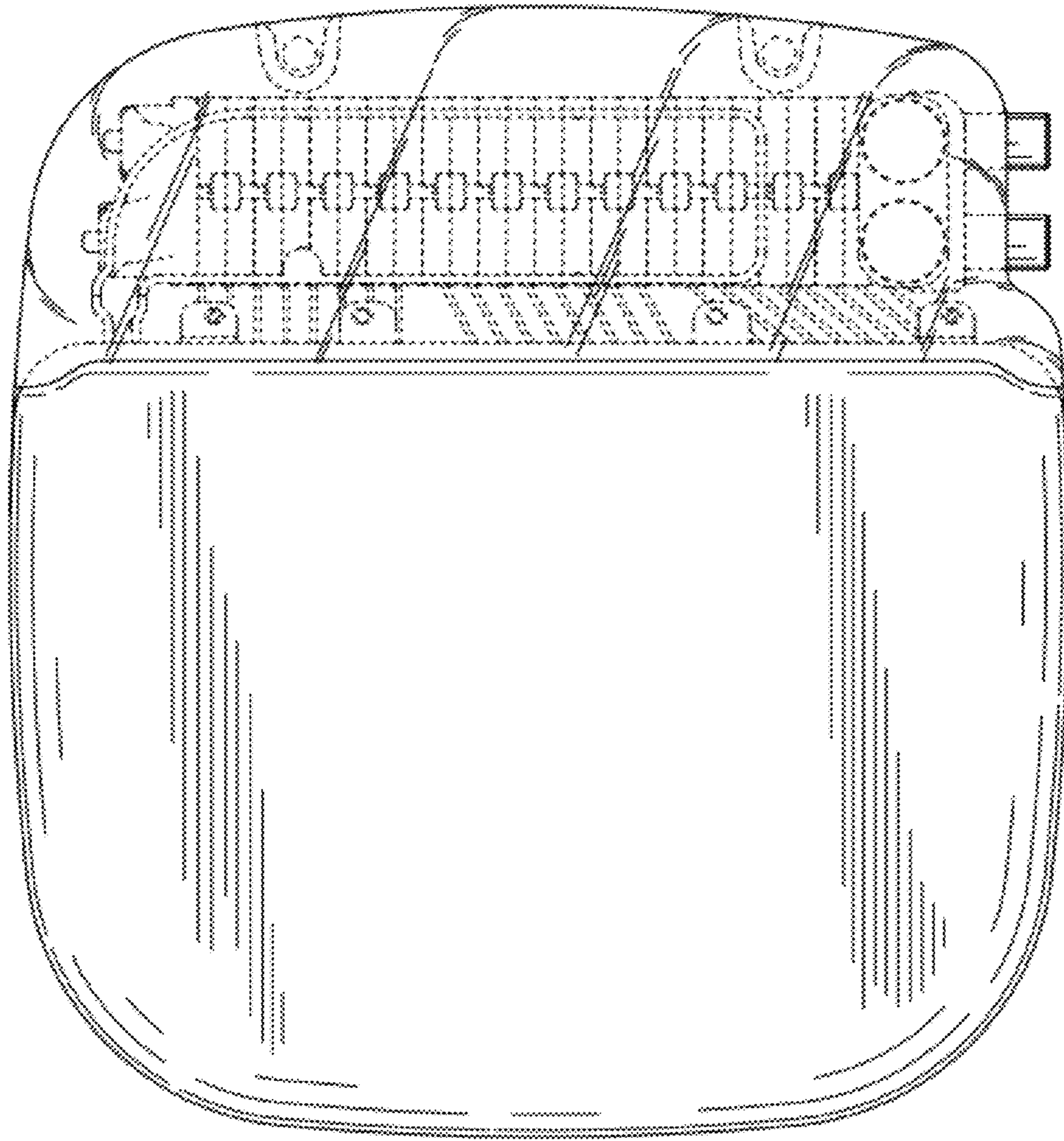
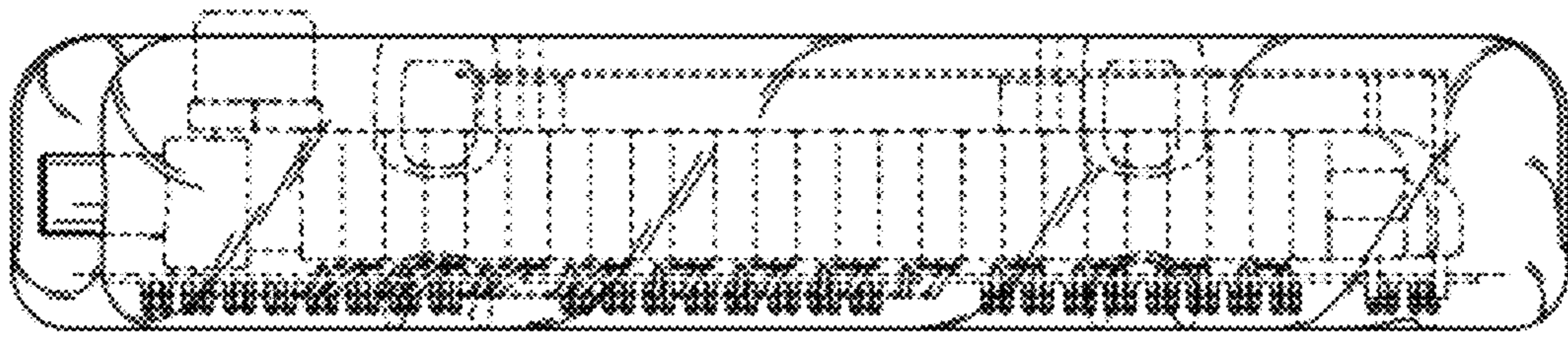

Fig. 3



**Fig. 4**



**Fig. 5**

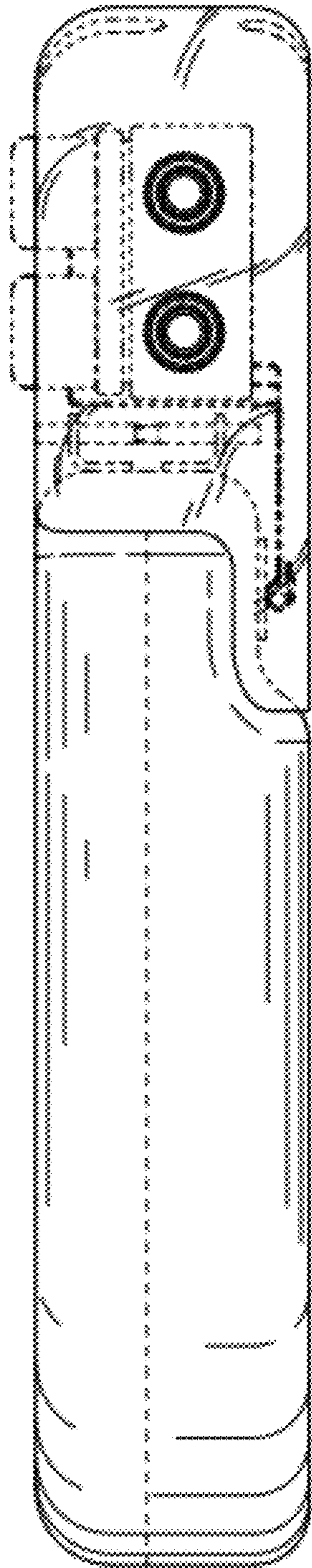

**Fig. 6**

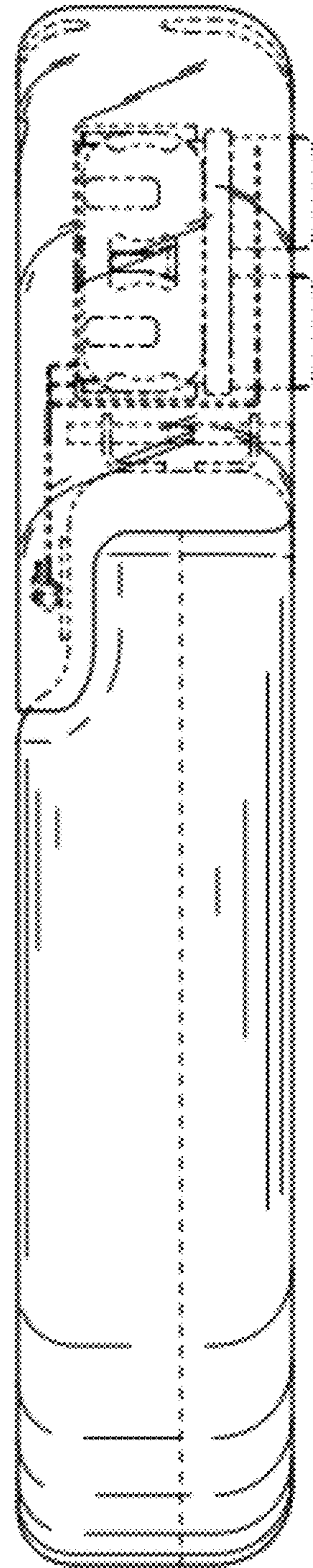

**Fig. 7**

UNITED STATES PATENT AND TRADEMARK OFFICE  
**CERTIFICATE OF CORRECTION**

PATENT NO. : D663,035 S  
APPLICATION NO. : 29/403072  
DATED : July 3, 2012  
INVENTOR(S) : Smith

Page 1 of 7

It is certified that error appears in the above-identified patent and that said Letters Patent is hereby corrected as shown below:

The title page showing the illustrative figure should be deleted to be replaced with the attached title page.

In the drawings, Figs 1, 2, 3, 4, 5, 6, and 7 should be replaced with the corrected Figs 1, 2, 3, 4, 5, 6, and 7 as shown on the attached pages.

Signed and Sealed this  
Twelfth Day of February, 2013



Teresa Stanek Rea  
*Acting Director of the United States Patent and Trademark Office*

(12) **United States Design Patent** (10) **Patent No.:** **US D663,035 S**  
**Smith** (45) **Date of Patent:** **\*\* Jul. 3, 2012**

(54) **TWO-PORT IMPLANTABLE MEDICAL DEVICE**

(75) Inventor: **Alexander K. Smith**, Chesterland, OH (US)

(73) Assignee: **Greatbatch Ltd.**, Clarence, NY (US)

(\*\*) Term: **14 Years**

(21) Appl. No.: **29/403,072**

(22) Filed: **Sep. 30, 2011**

(51) **LOC (9) Cl.** ..... **24-03**

(52) **U.S. Cl.** ..... **D24/187; D24/167**

(58) **Field of Classification Search** ..... D24/144, D24/158, 164, 167, 168, 170, 186-187, 200, D24/231, 155; 600/300, 301, 368, 372, 481, 600/529, 544, 554, 561; 607/2, 4, 5, 9, 30  
 See application file for complete search history.

(56) **References Cited**

**U.S. PATENT DOCUMENTS**

D261,552 S *	10/1981	Boroda	.....	D24/200
D269,205 S *	5/1983	Langer et al.	.....	D24/167
D280,930 S *	10/1985	Speicher et al.	.....	D24/167
D337,820 S *	7/1993	Hooper et al.	.....	D24/155
D338,731 S *	8/1993	Byland et al.	.....	D24/167
D343,901 S *	2/1994	Anderson	.....	D24/167
D478,990 S *	8/2003	Kroll	.....	D24/167

D523,144 S *	6/2006	Wenger et al.	.....	D24/155
D559,987 S *	1/2008	Strother et al.	.....	D24/187
D598,552 S *	8/2009	Potts et al.	.....	D24/187
D598,553 S *	8/2009	Potts et al.	.....	D24/187
D599,910 S *	9/2009	Potts et al.	.....	D24/187
D610,261 S *	2/2010	Strother et al.	.....	D24/186
D613,868 S *	4/2010	Lhuillery et al.	.....	D24/187
2008/0208267 A1 *	8/2008	Alexander et al.	.....	607/2

\* cited by examiner

*Primary Examiner* — T. Chase Nelson

*Assistant Examiner* — Mark Cavanna

(74) *Attorney, Agent, or Firm* — Pearne & Gordon LLP

(57) **CLAIM**

The ornamental design for a two-port implantable medical device, as shown and described.

**DESCRIPTION**

FIG. 1 is a front perspective view of a two-port implantable medical device showing my new design; FIG. 2 is a front view thereof; FIG. 3 is a rear view thereof; FIG. 4 is a top view thereof; FIG. 5 is a bottom view thereof; FIG. 6 is a left side view thereof; and, FIG. 7 is a right side view thereof.

The portions of my design shown in broken lines are provided for illustrative purposes only and form no part of the claimed design.

**1 Claim, 5 Drawing Sheets**

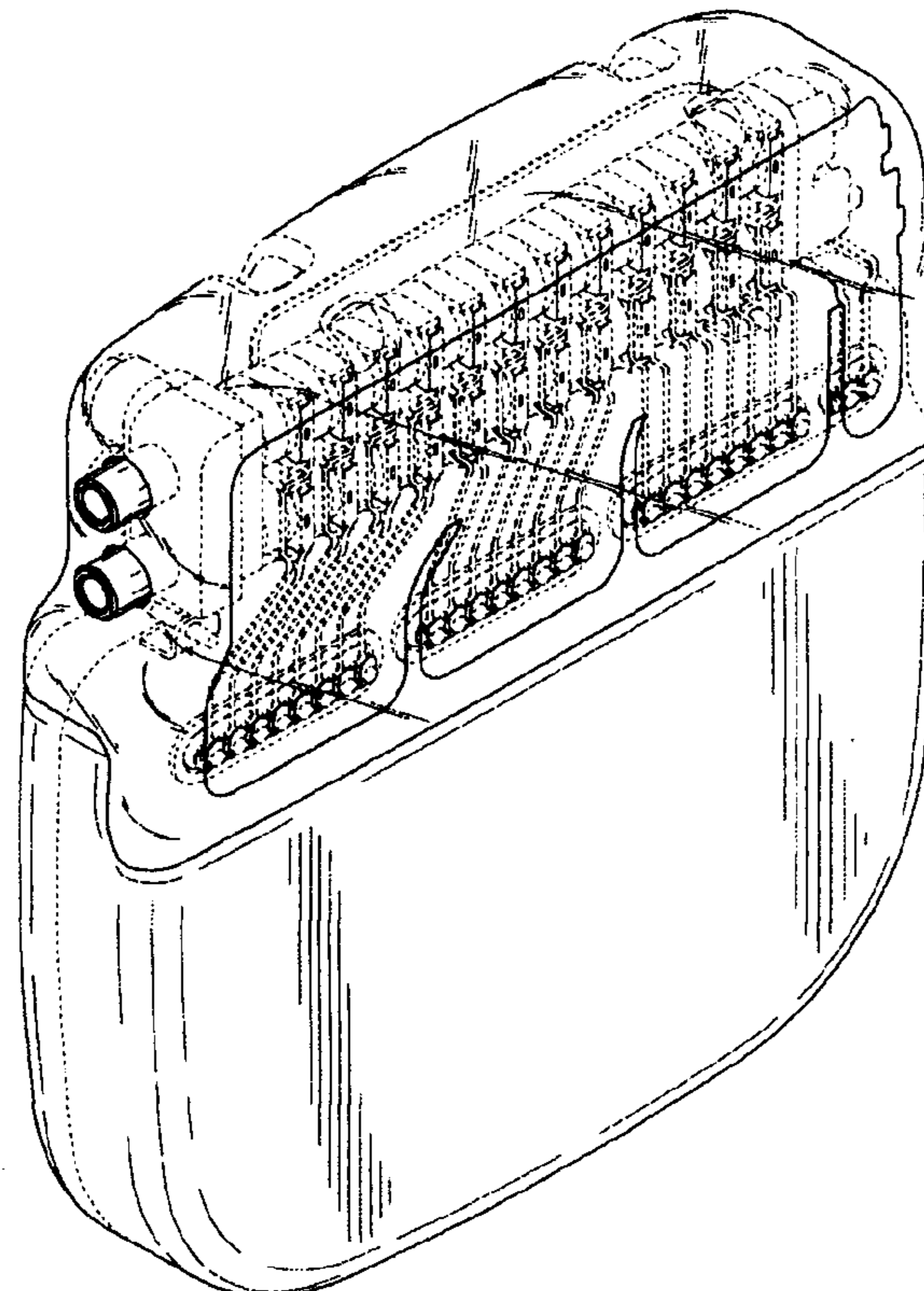



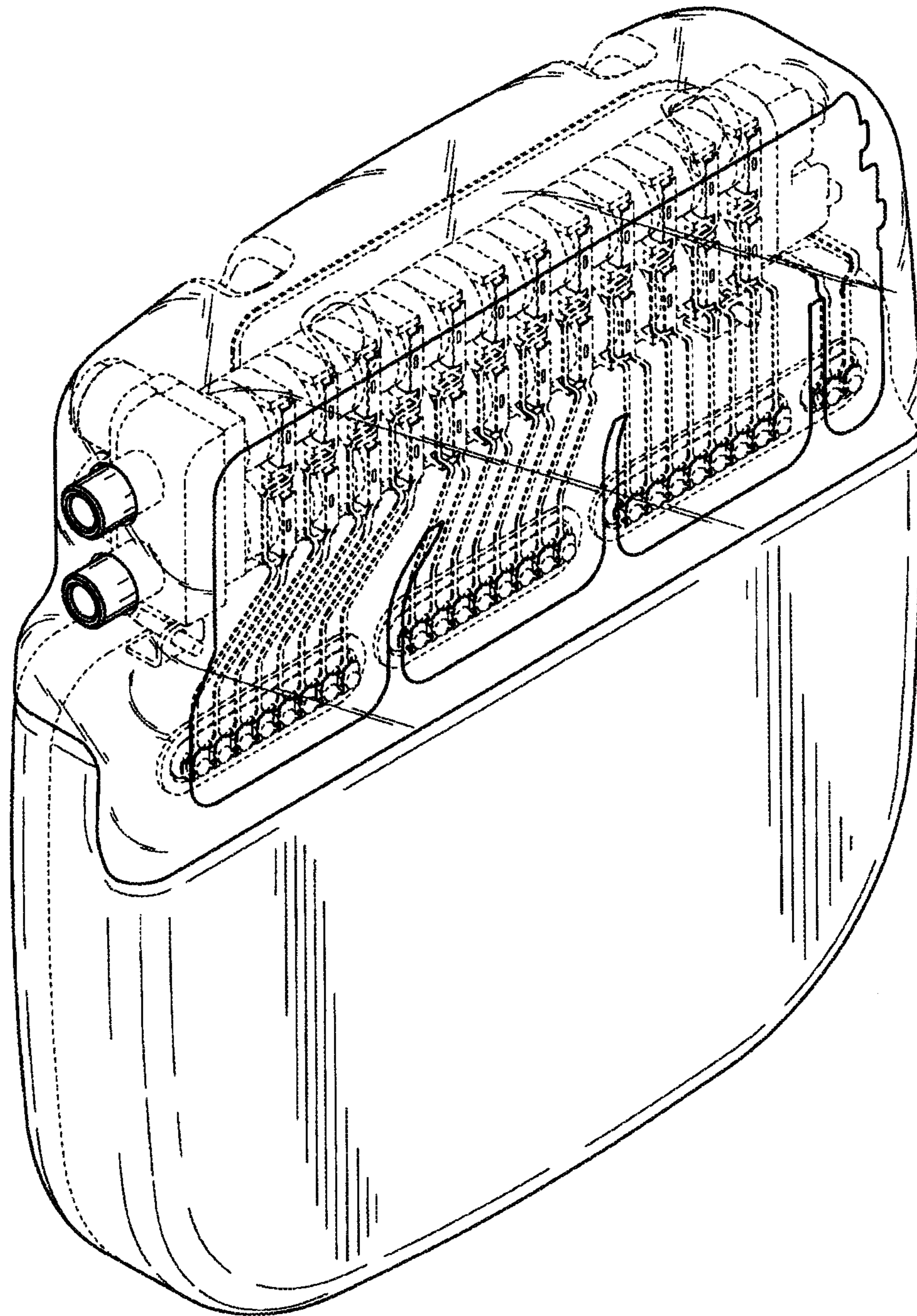

**Fig. 1**

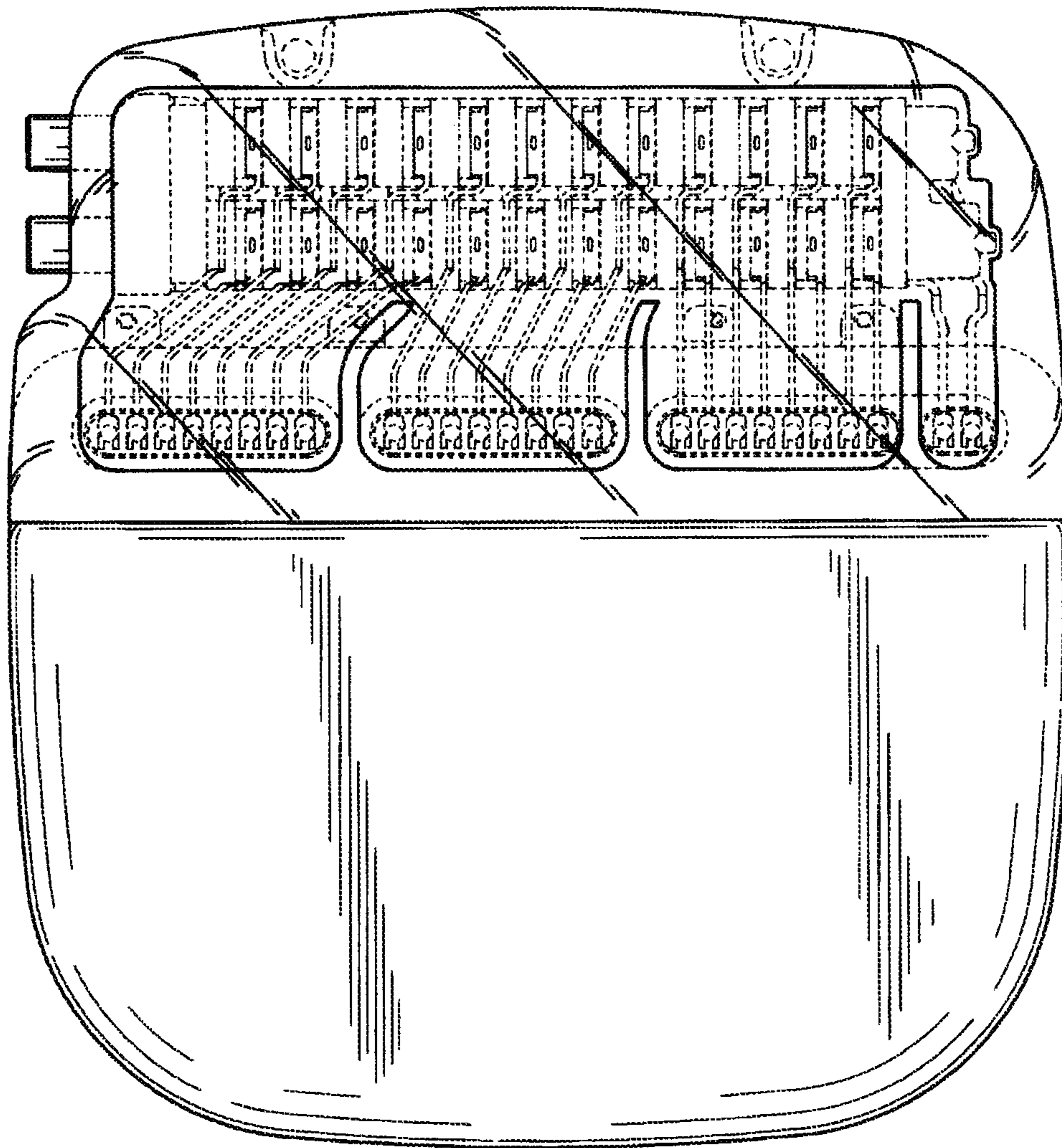

Fig. 2

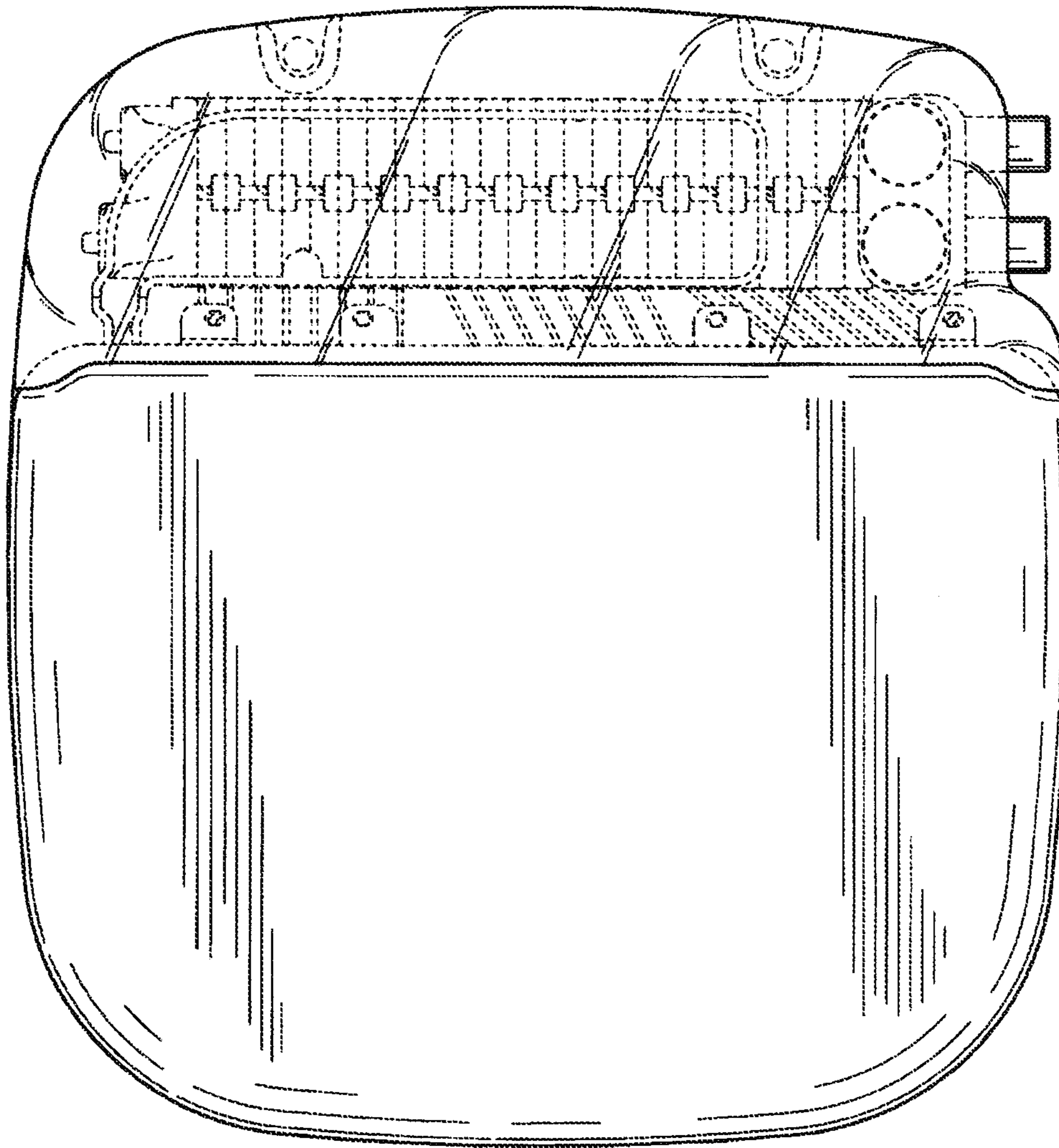
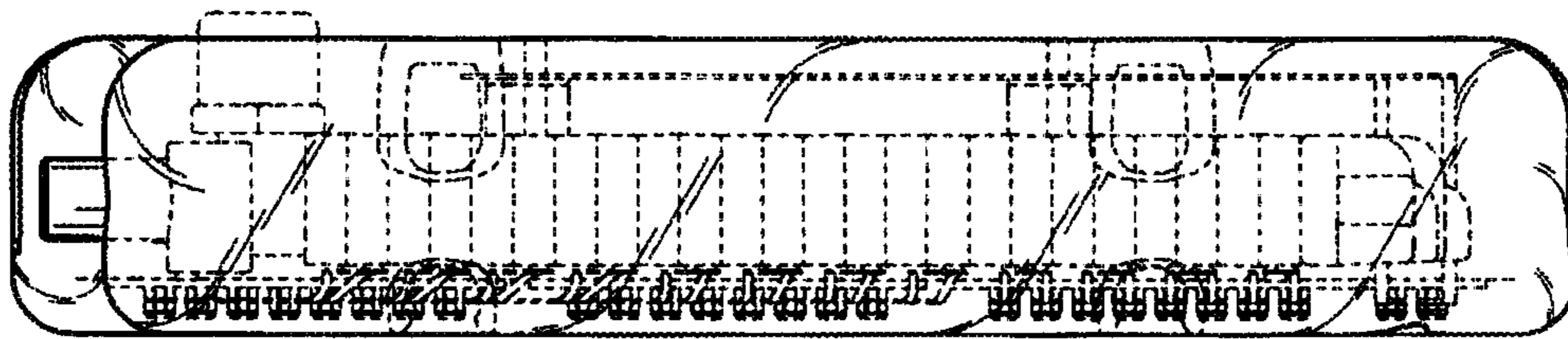
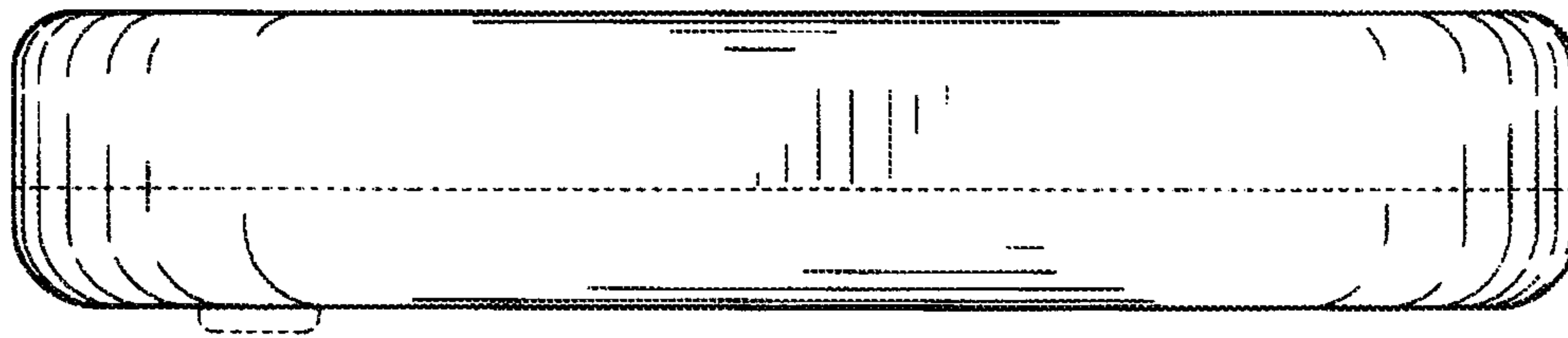

Fig. 3



**Fig. 4**



**Fig. 5**

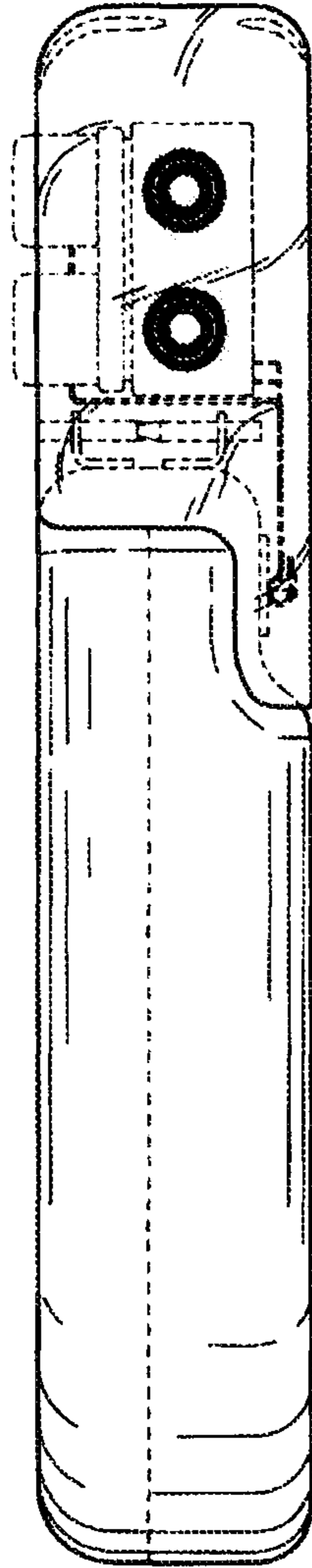

**Fig. 6**

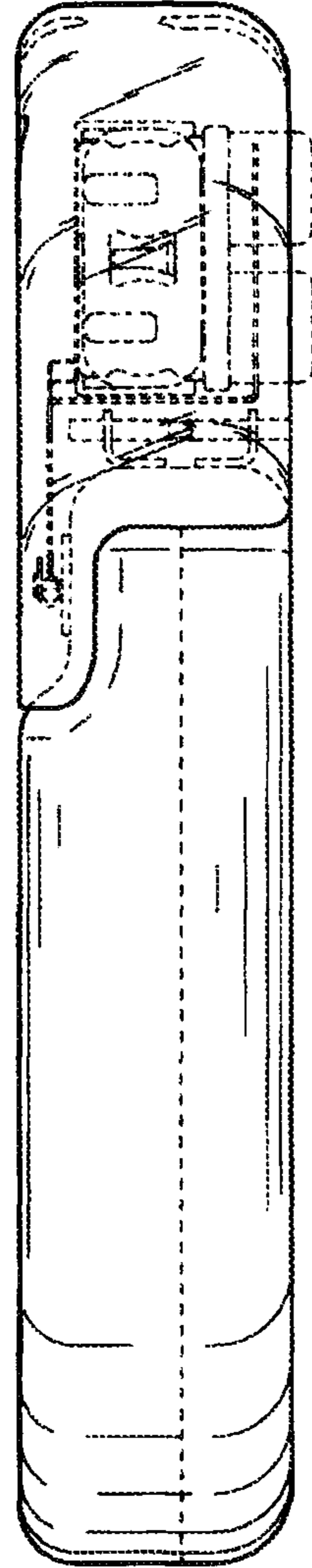

**Fig. 7**