



US00D662167S

(12) **United States Design Patent**
Juarez

(10) **Patent No.:** **US D662,167 S**
(45) **Date of Patent:** **** Jun. 19, 2012**

- (54) **GUN CHASSIS**
- (75) Inventor: **Justin R. Juarez**, Longmont, CO (US)
- (73) Assignee: **Kinetic Research Group, Ltd.**,
Longmont, CO (US)
- (**) Term: **14 Years**
- (21) Appl. No.: **29/393,712**
- (22) Filed: **Jun. 8, 2011**
- (51) **LOC (9) Cl.** **22-01**
- (52) **U.S. Cl.** **D22/103; D22/108**
- (58) **Field of Classification Search** D22/100,
D22/101, 103, 104, 108, 199; D21/572,
D21/573; 42/51, 71.01, 75.01, 75.02, 90,
42/94, 134, 136, 139, 125, 72, 111; 362/110;
89/40.06, 41.19, 37.04, 33.04, 191.01, 200-204;
124/67, 66, 72, 74
See application file for complete search history.

7,823,319	B2 *	11/2010	Casas Salva	42/96
D631,526	S *	1/2011	Torre et al.	D22/108
D637,681	S *	5/2011	Bentley et al.	D22/108
D642,228	S *	7/2011	Torre et al.	D21/573
2011/0314717	A1 *	12/2011	Barrett	42/75.03
2012/0023800	A1 *	2/2012	Laney	42/8

OTHER PUBLICATIONS

Juarez, Justin R., Sneak Peak at Whiskey-3 Chassis, web page at Sniper's Hide Forum, Nov. 2, 2010 <http://www.snipershide.com/forum/ubbthreads.php?ubb=showflat&Number=2381434&page=1>.

* cited by examiner

Primary Examiner — Michael Pratt

(74) *Attorney, Agent, or Firm* — Geoffrey E. Dobbin

(57) **CLAIM**

The ornamental design for the gun chassis, as shown and described.

DESCRIPTION

- FIG. 1 is an upper perspective view of the gun chassis.
- FIG. 2 is a front elevation of the gun chassis.
- FIG. 3 is a rear elevation of the gun chassis.
- FIG. 4 is a left elevation of the gun chassis.
- FIG. 5 is a right elevation of the gun chassis.
- FIG. 6 is a top plan view of the gun chassis.
- FIG. 7 is a bottom plan view fo the gun chassis; and,
- FIG. 8 is a lower perspective view of the gun chassis.

1 Claim, 4 Drawing Sheets

(56) **References Cited**

U.S. PATENT DOCUMENTS

5,711,102	A *	1/1998	Plaster et al.	42/71.01
6,301,817	B1 *	10/2001	Hogue et al.	42/71.01
6,487,805	B1 *	12/2002	Reynolds	42/75.03
6,637,142	B1 *	10/2003	Reynolds	42/75.03
7,665,240	B1 *	2/2010	Bentley	42/75.03
7,726,060	B1 *	6/2010	Jones	42/75.02
7,802,392	B2 *	9/2010	Peterson et al.	42/75.03

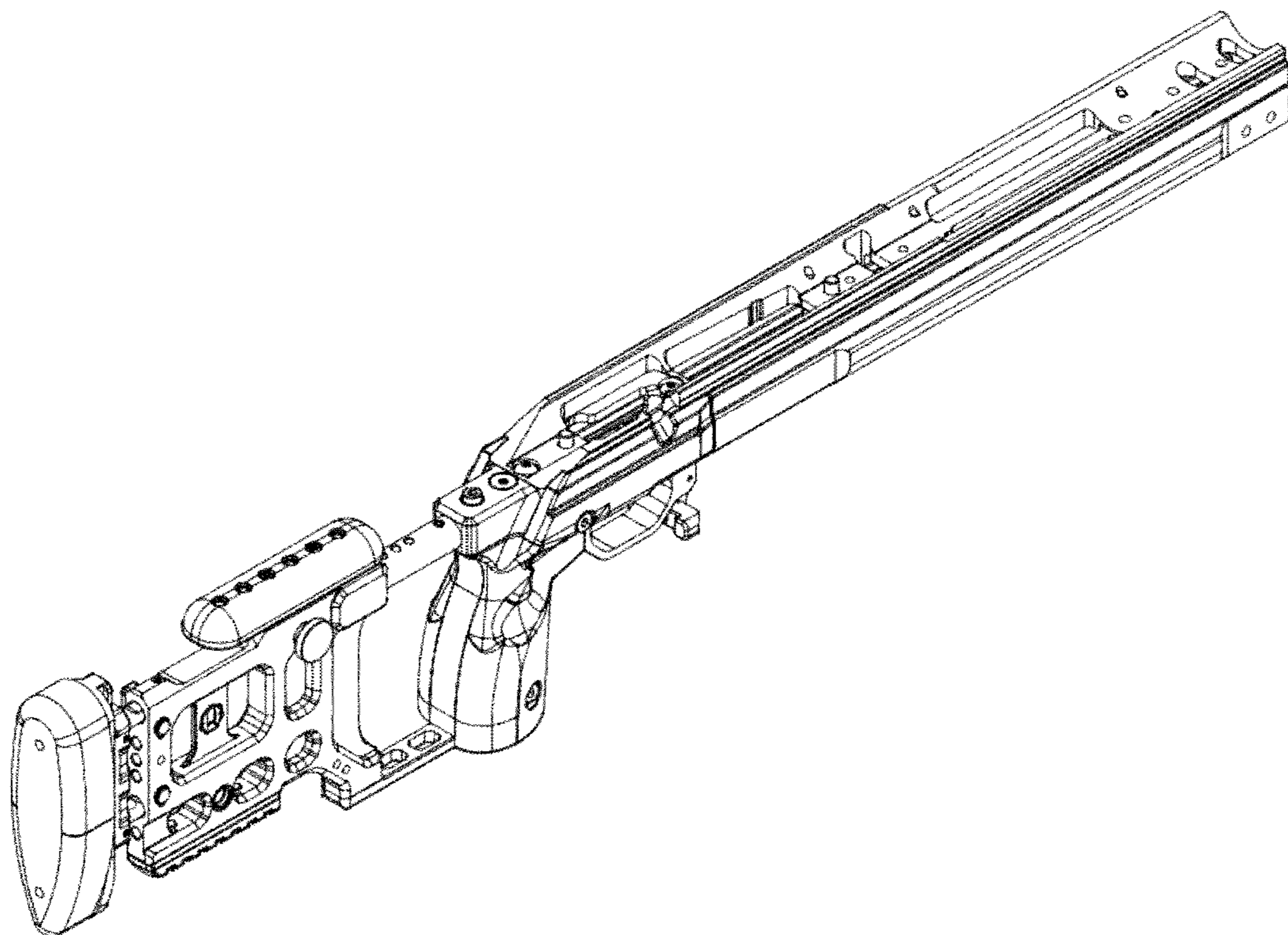

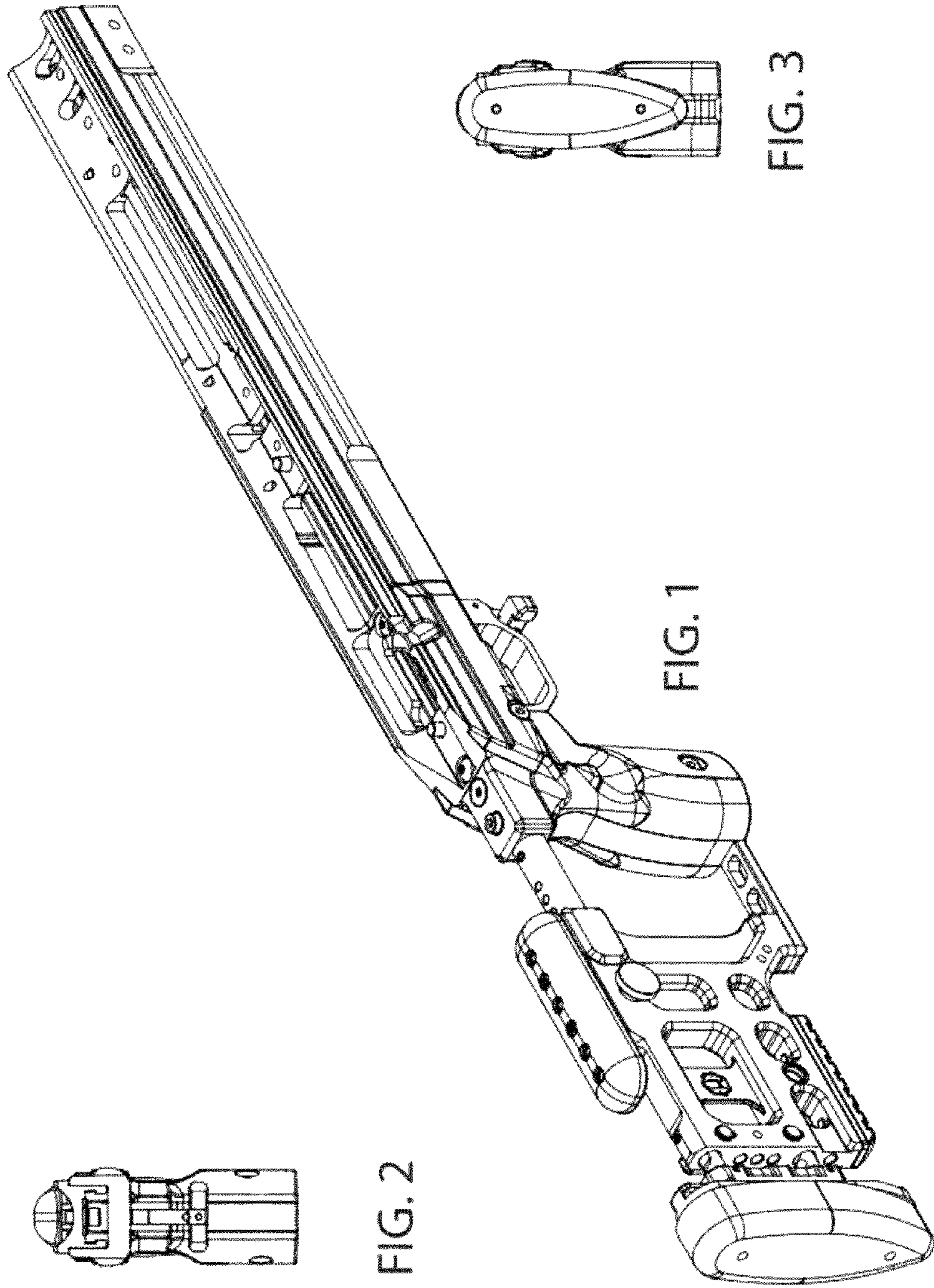

FIG. 2

FIG. 1

FIG. 3

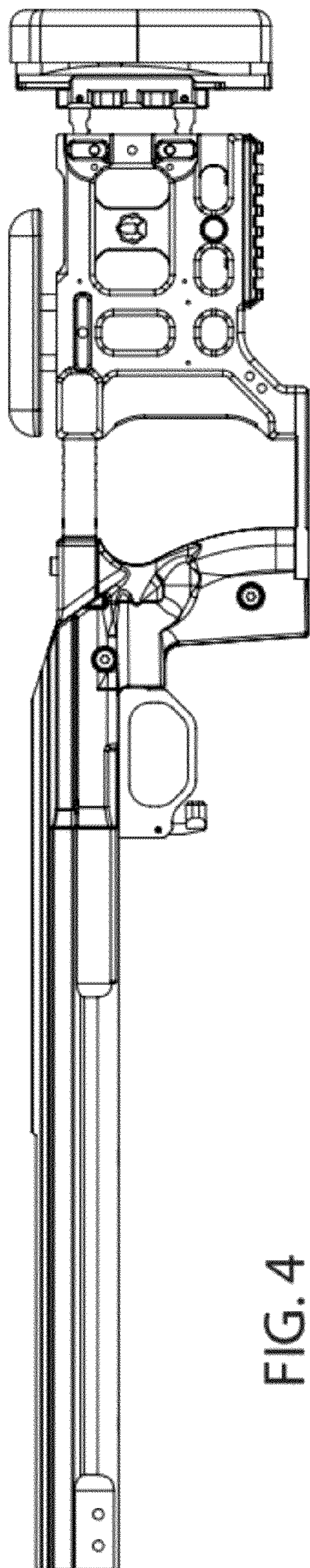

FIG. 4

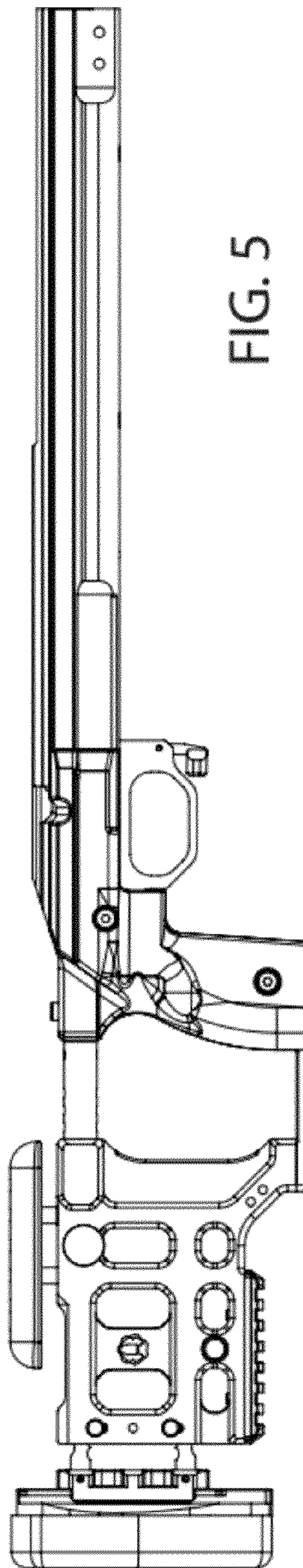

FIG. 5

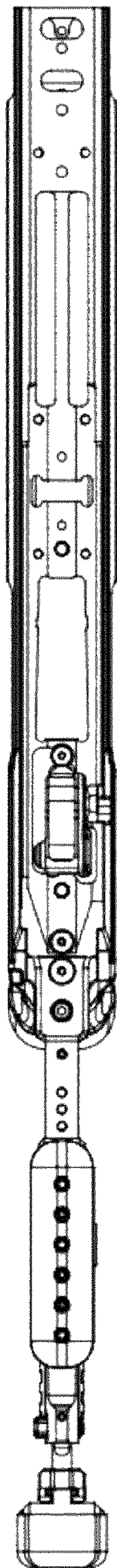

FIG. 6

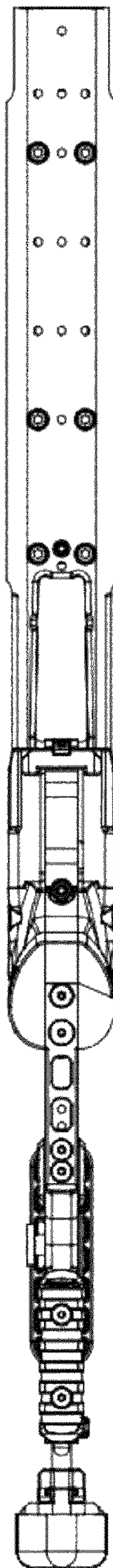

FIG. 7

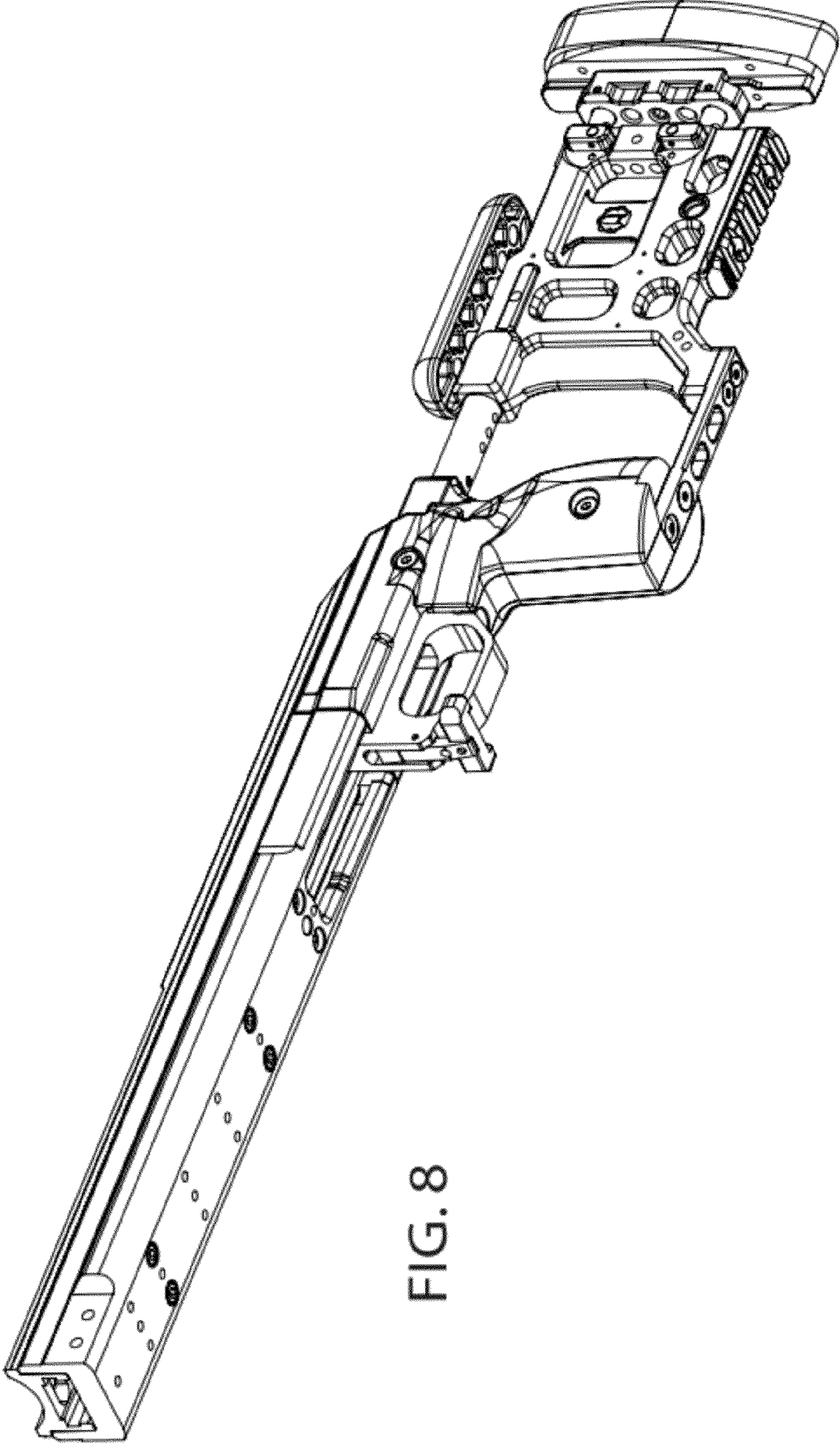

FIG. 8