



US00D662094S

(12) **United States Design Patent**
Mack et al.

(10) **Patent No.:** **US D662,094 S**
(45) **Date of Patent:** **** Jun. 19, 2012**

(54) **INDUSTRIAL OPERATOR INTERFACE**
TERMINAL

(75) Inventors: **Melissa A. Mack**, Painesville, OH (US);
Cheryl Lynn Ades Anspach, Waukesha,
WI (US); **Douglas A. Lostoski**,
Richfield, OH (US); **Gordon Daily**,
Solon, OH (US); **Peter J. Klein**,
Kenosha, WI (US); **Ronald E. Bliss**,
Twinsburg, OH (US)

(73) Assignee: **Rockwell Automation Technologies,**
Inc., Mayfield Heights, OH (US)

(**) Term: **14 Years**

(21) Appl. No.: **29/393,523**

(22) Filed: **Jun. 6, 2011**

(51) **LOC (9) Cl.** **14-02**

(52) **U.S. Cl.** **D14/388**; D14/336; D14/371

(58) **Field of Classification Search** D14/341,
D14/371-375, 125-129, 336, 337, 388; 341/12,
341/22; 345/104, 156, 168, 173; 348/180,
348/184, 325, 739; 349/1, 2, 11, 62;
361/679.05-679.07, 679.21; D6/300, 308;
D13/164; 200/512, 600; 715/763, 764, 813;
D19/52

See application file for complete search history.

(56) **References Cited**

U.S. PATENT DOCUMENTS

4,237,636 A 12/1980 Matthews
4,342,029 A 7/1982 Hofmanis et al.
4,572,592 A 2/1986 Haven
4,680,429 A 7/1987 Murdock et al.
4,818,980 A 4/1989 Strosser et al.
4,888,479 A 12/1989 Tamaru
5,049,870 A 9/1991 Fitzgerald et al.
5,239,152 A 8/1993 Caldwell et al.
D339,379 S * 9/1993 Persing D19/52
5,422,751 A 6/1995 Lewis et al.
D378,514 S 3/1997 Kruse
5,726,668 A 3/1998 Clement
D420,342 S 2/2000 Murray

6,116,063 A 9/2000 Foslien
6,215,477 B1 4/2001 Morrison et al.
6,268,845 B1 7/2001 Pariza et al.
6,462,939 B1 10/2002 Heirich
6,567,077 B2 5/2003 Inoue et al.
6,578,972 B1 6/2003 Heirich et al.
D481,057 S 10/2003 Brady
6,653,864 B2 11/2003 Iwagami et al.
6,667,781 B2 12/2003 Ek et al.
D490,420 S 5/2004 Solomon et al.
6,762,762 B2 7/2004 MacInnis et al.
6,826,038 B2 11/2004 Chen
D504,889 S * 5/2005 Andre et al. D14/341
6,972,401 B2 12/2005 Akitt et al.
7,026,567 B2 4/2006 Mai et al.
7,143,361 B2 11/2006 Ramchandani
7,173,185 B1 2/2007 Cloran et al.
D541,800 S 5/2007 Ponnert et al.
7,265,971 B2 9/2007 Chen et al.
7,268,311 B2 9/2007 Tanabe et al.
D554,640 S 11/2007 Ponnert et al.
D558,756 S 1/2008 Andre et al.
7,349,040 B2 3/2008 Lee et al.
7,365,970 B2 4/2008 Cheng et al.
D575,248 S * 8/2008 Fujii et al. D14/126
7,423,555 B2 * 9/2008 Chai 341/22
7,440,264 B2 10/2008 Lam et al.
D580,387 S 11/2008 Andre et al.
D580,431 S * 11/2008 Morita D14/341
7,460,362 B2 12/2008 Lam et al.
D593,087 S 5/2009 Andre et al.
D602,487 S * 10/2009 Maskatia D14/341
D608,302 S 1/2010 Liu
7,679,609 B2 3/2010 Matsumoto et al.
7,679,893 B2 3/2010 Lam et al.
D613,735 S 4/2010 Andre et al.
7,716,600 B2 5/2010 Sawano
7,724,509 B2 5/2010 Lam et al.
D620,455 S 7/2010 Teixeira Pinto Dias
7,762,452 B2 7/2010 Androsyuk et al.
7,766,517 B2 8/2010 Kerr et al.
D627,777 S * 11/2010 Akana et al. D14/341
D630,636 S * 1/2011 Jeon et al. D14/374
D634,318 S * 3/2011 Buckle et al. D14/341
D636,769 S * 4/2011 Wood et al. D14/341
2002/0100677 A1 8/2002 Fukui et al.
2006/0097989 A1 * 5/2006 Ho 345/173
2007/0267285 A1 * 11/2007 Yamaue et al. 200/512

OTHER PUBLICATIONS

Wonderware Industrial Computers—Extending the Power of
Wonderware—Everywhere. Last accessed on May 10, 2011, 12
pages.

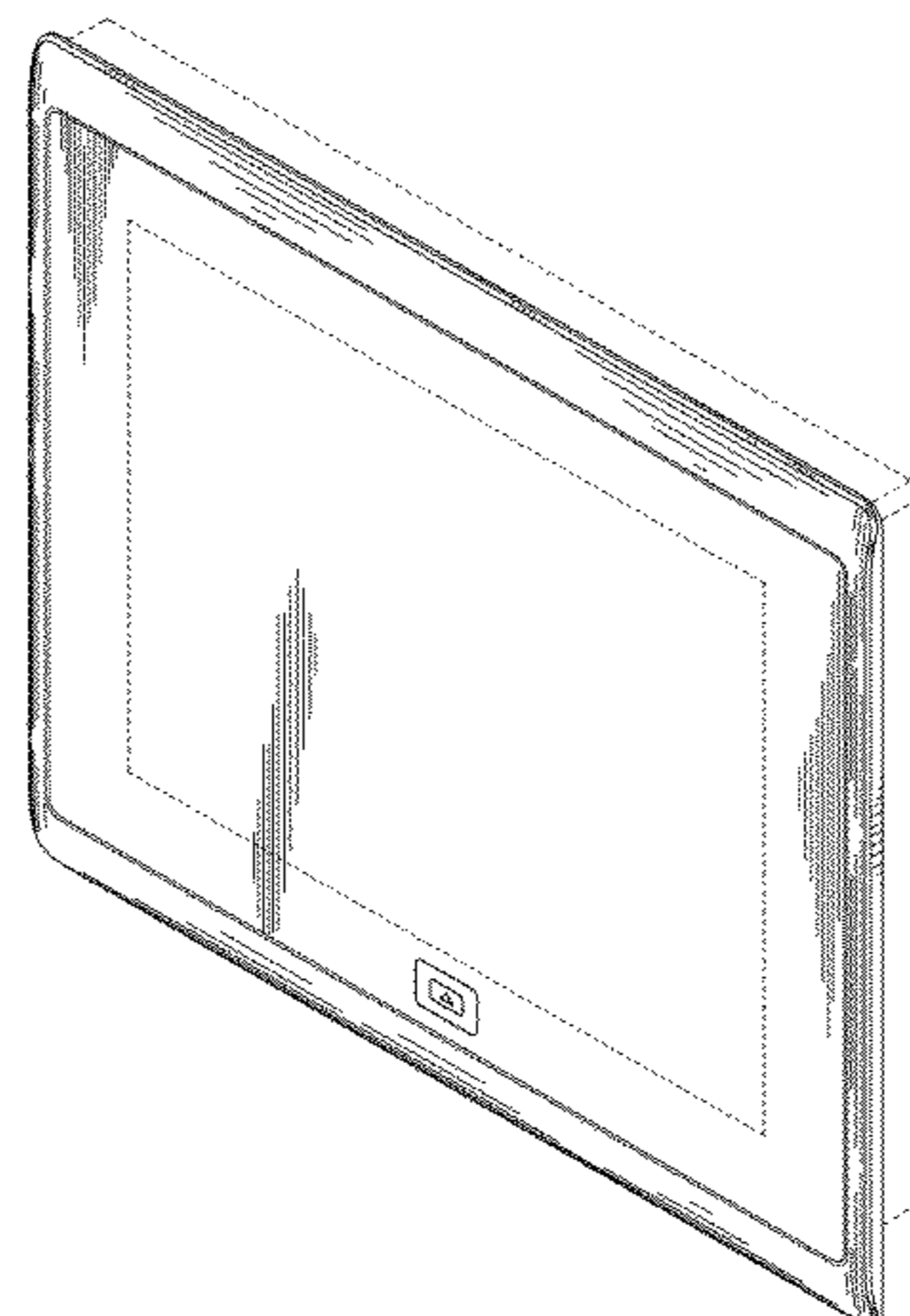

Siemens HMI Terminals—SIMATIC Panels. Brochure—Nov. 2010. Last accessed on Mar. 31, 2011, 38 pages.
 Honeywell 900 Control Station Specifications 51-52-03-46. Apr. 2009. Last accessed on May 10, 2011, 14 pages.
 Honeywell HMI Terminals—Apr. 2009. Last accessed Mar. 31, 2011, 14 pages.
 Hakko HMI Terminals—V8 Series. Last accessed Mar. 31, 2011, 18 pages.
 Beijer HMI Terminals, 2010, Beijer Electronics. Last accessed on Mar. 31, 2011, 2 pages.
 Eaton HMI Terminals—Operator Interface Products. vol. 7—Motor Controls, Logic and Connectivity, Feb. 2011, Last accessed on Mar. 31, 2011, 70 pages.
 Beckhoff. “New Automation Technology”. Beckhoff Automation GmbH, 80 pages.

* cited by examiner

Primary Examiner — Freda S Nunn
 (74) *Attorney, Agent, or Firm* — Turocy & Watson, LLP;
 Alexander R. Kuszewski; John M. Miller

(57) **CLAIM**
 The ornamental design for an industrial operator interface terminal, substantially as shown and described.

DESCRIPTION

FIG. 1 is a front perspective view of an ornamental design of an industrial operator interface terminal.
 FIG. 2 is a front elevational view of the industrial operator interface terminal shown in FIG. 1.
 FIG. 3 is a back elevational view of the industrial operator interface terminal shown in FIG. 1.
 FIG. 4 is a left side elevational view of the industrial operator interface terminal shown in FIG. 1.
 FIG. 5 is a right side elevational view of the industrial operator interface terminal shown in FIG. 1.
 FIG. 6 is a top plan view of the industrial operator interface terminal shown in FIG. 1.
 FIG. 7 is a bottom plan view of the industrial operator interface terminal shown in FIG. 1.
 FIG. 8 is a front perspective view of an ornamental design of an industrial operator interface terminal.
 FIG. 9 is a front elevational view of the industrial operator interface terminal shown in FIG. 8.
 FIG. 10 is a back elevational view of the industrial operator interface terminal shown in FIG. 8.
 FIG. 11 is a left side elevational view of the industrial operator interface terminal shown in FIG. 8.
 FIG. 12 is a right side elevational view of the industrial operator interface terminal shown in FIG. 8.
 FIG. 13 is a top plan view of the industrial operator interface terminal shown in FIG. 8.
 FIG. 14 is a bottom plan view of the industrial operator interface terminal shown in FIG. 8.
 FIG. 15 is a front perspective view of an ornamental design of an industrial operator interface terminal.
 FIG. 16 is a front elevational view of the industrial operator interface terminal shown in FIG. 15.

FIG. 17 is a back elevational view of the industrial operator interface terminal shown in FIG. 15.
 FIG. 18 is a left side elevational view of the industrial operator interface terminal shown in FIG. 15.
 FIG. 19 is a right side elevational view of the industrial operator interface terminal shown in FIG. 15.
 FIG. 20 is a top plan view of the industrial operator interface terminal shown in FIG. 15.
 FIG. 21 is a bottom plan view of the industrial operator interface terminal shown in FIG. 15.
 FIG. 22 is a front perspective view of an ornamental design of an industrial operator interface terminal.
 FIG. 23 is a front elevational view of the industrial operator interface terminal shown in FIG. 22.
 FIG. 24 is a back elevational view of the industrial operator interface terminal shown in FIG. 22.
 FIG. 25 is a left side elevational view of the industrial operator interface terminal shown in FIG. 22.
 FIG. 26 is a right side elevational view of the industrial operator interface terminal shown in FIG. 22.
 FIG. 27 is a top plan view of the industrial operator interface terminal shown in FIG. 22.
 FIG. 28 is a bottom plan view of the industrial operator interface terminal shown in FIG. 22.
 FIG. 29 is a front perspective view of an ornamental design of an industrial operator interface terminal.
 FIG. 30 is a front elevational view of the industrial operator interface terminal shown in FIG. 29.
 FIG. 31 is a back elevational view of the industrial operator interface terminal shown in FIG. 29.
 FIG. 32 is a left side elevational view of the industrial operator interface terminal shown in FIG. 29.
 FIG. 33 is a right side elevational view of the industrial operator interface terminal shown in FIG. 29.
 FIG. 34 is a top plan view of the industrial operator interface terminal shown in FIG. 29.
 FIG. 35 is a bottom plan view of the industrial operator interface terminal shown in FIG. 29.
 FIG. 36 is a front perspective view of an ornamental design of an industrial operator interface terminal.
 FIG. 37 is a front elevational view of the industrial operator interface terminal shown in FIG. 36.
 FIG. 38 is a back elevational view of the industrial operator interface terminal shown in FIG. 36.
 FIG. 39 is a left side elevational view of the industrial operator interface terminal shown in FIG. 36.
 FIG. 40 is a right side elevational view of the industrial operator interface terminal shown in FIG. 36.
 FIG. 41 is a top plan view of the industrial operator interface terminal shown in FIG. 36; and,
 FIG. 42 is a bottom plan view of the industrial operator interface terminal shown in FIG. 36.
 Broken lines shown in the drawings illustrate portions of the industrial operator interface terminal and form no part of the claimed design.

1 Claim, 30 Drawing Sheets

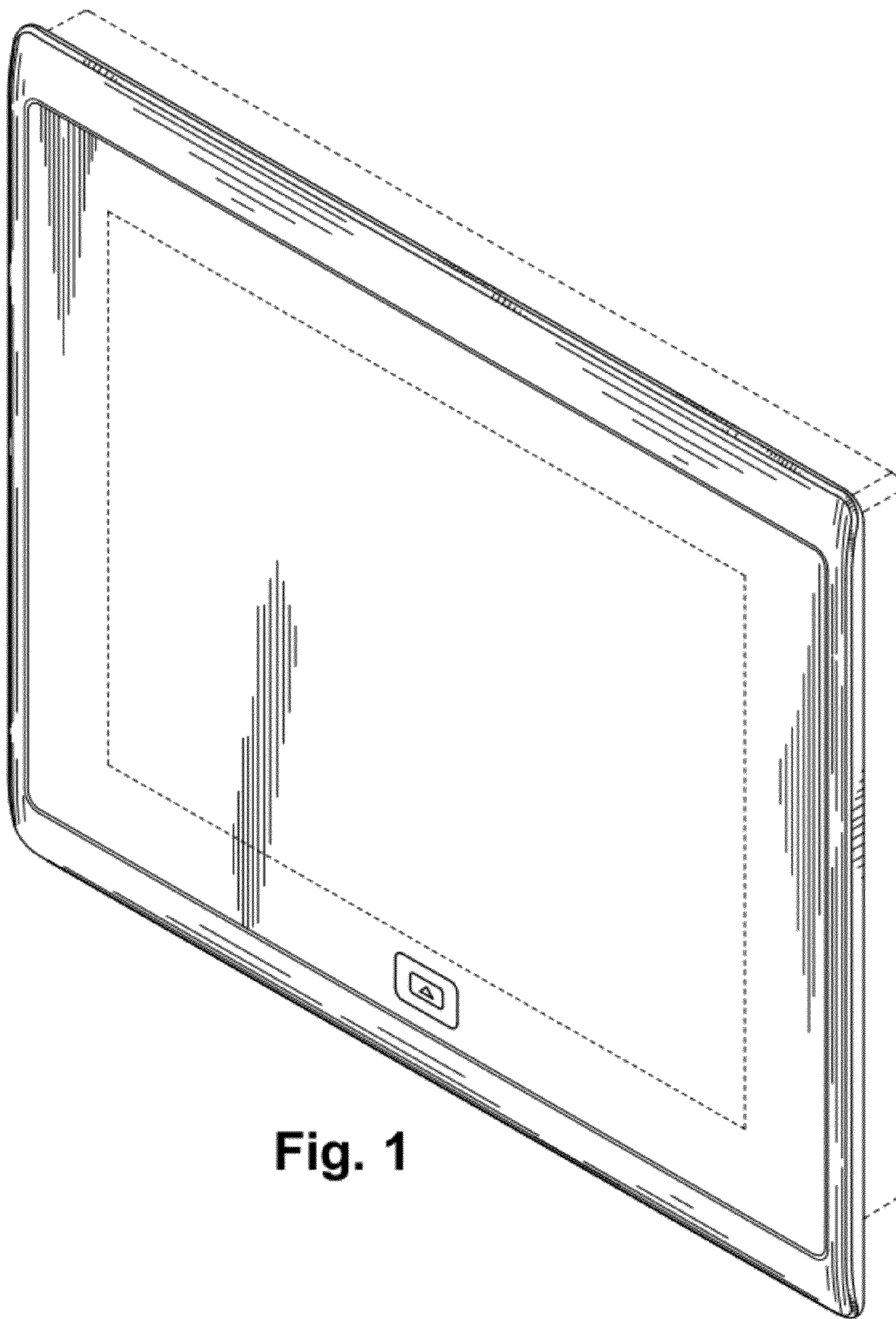

Fig. 1

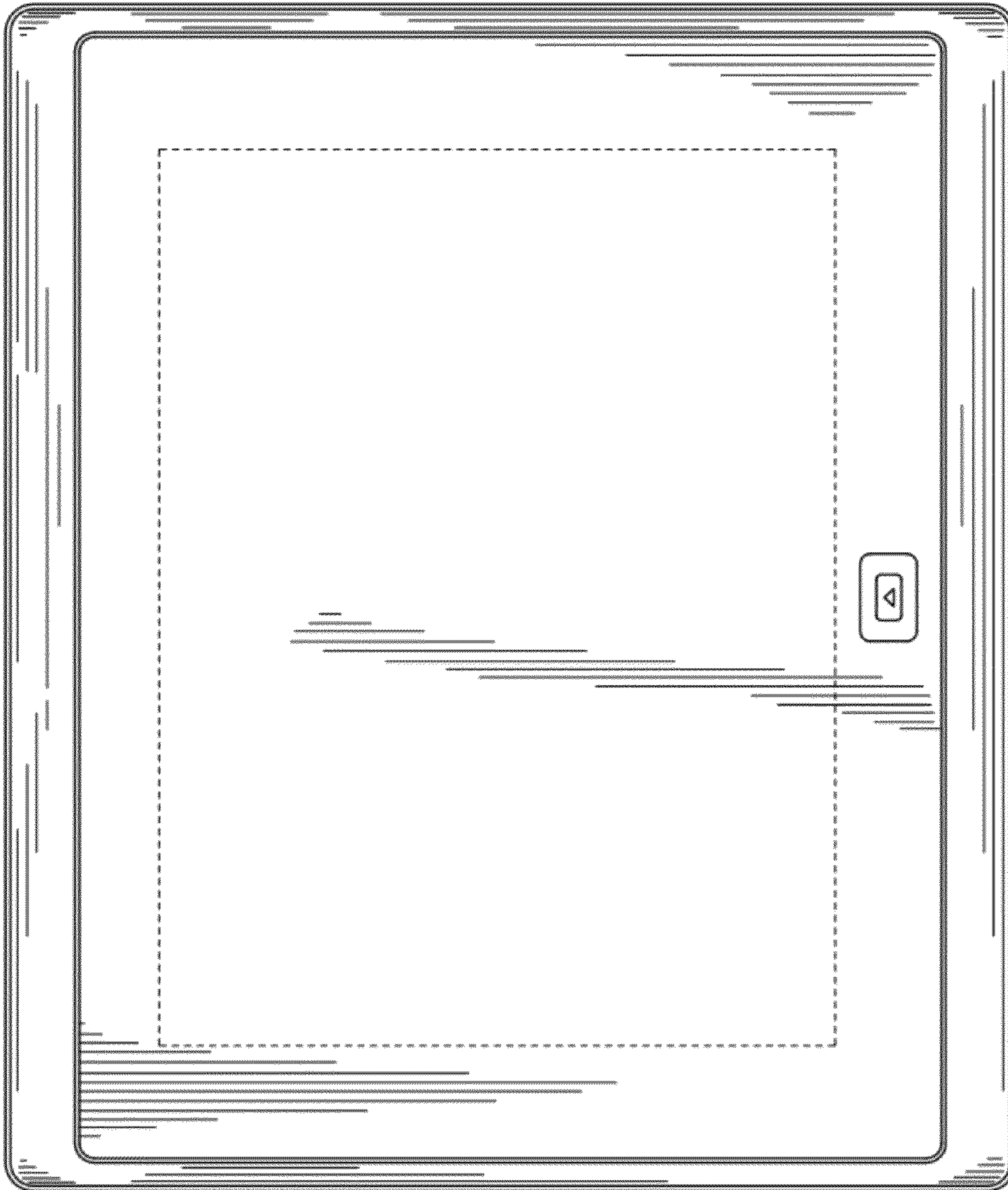

Fig. 2

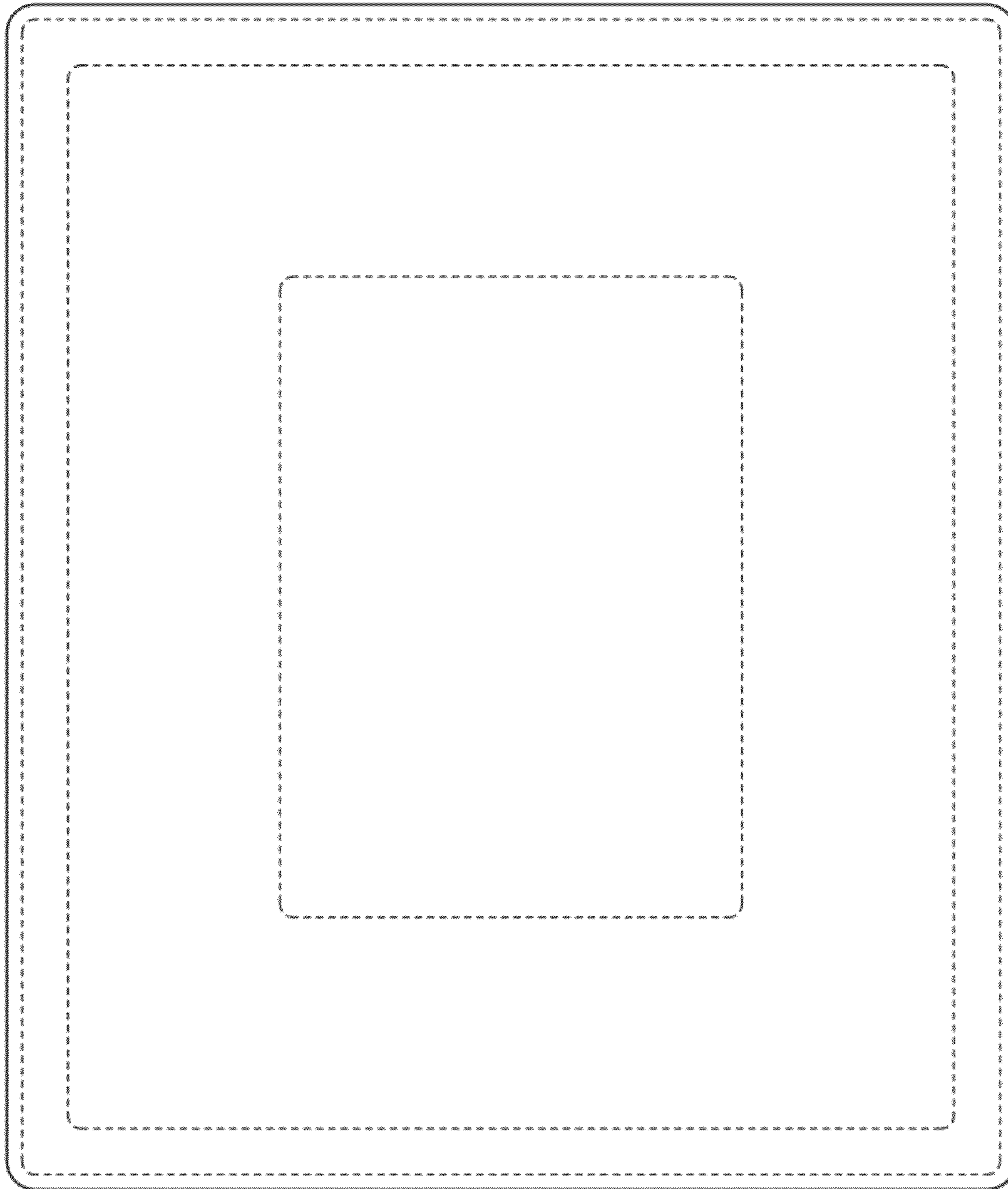

Fig. 3

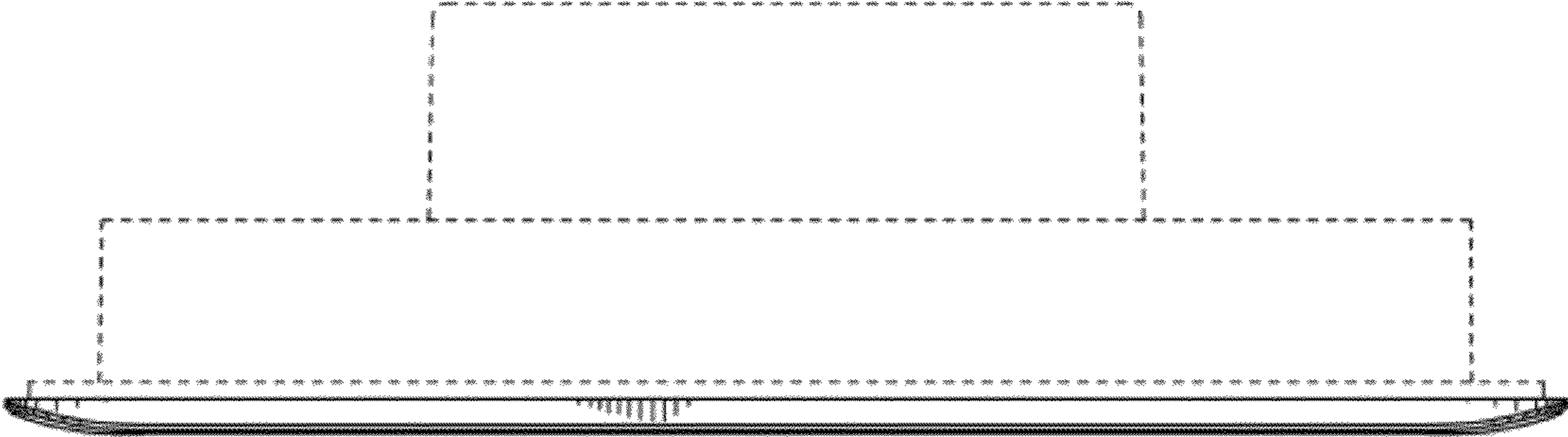

Fig. 5

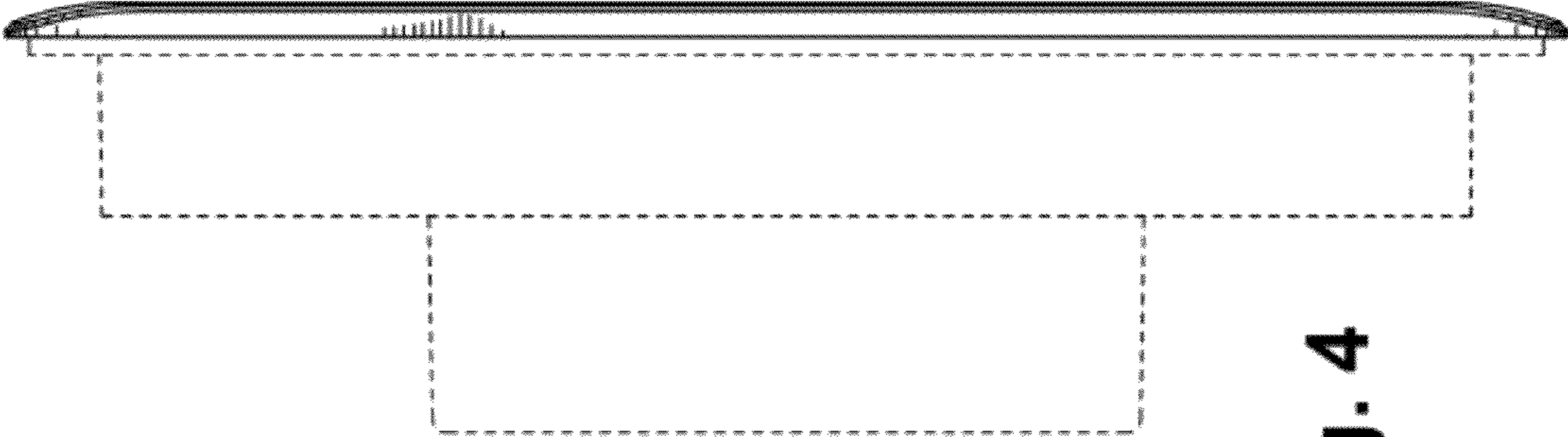

Fig. 4

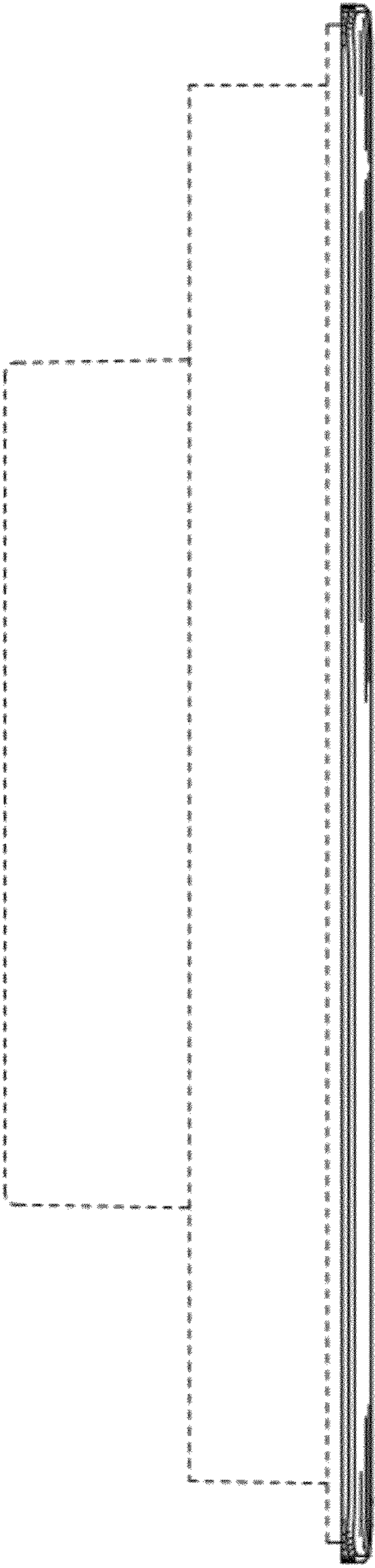

Fig. 6

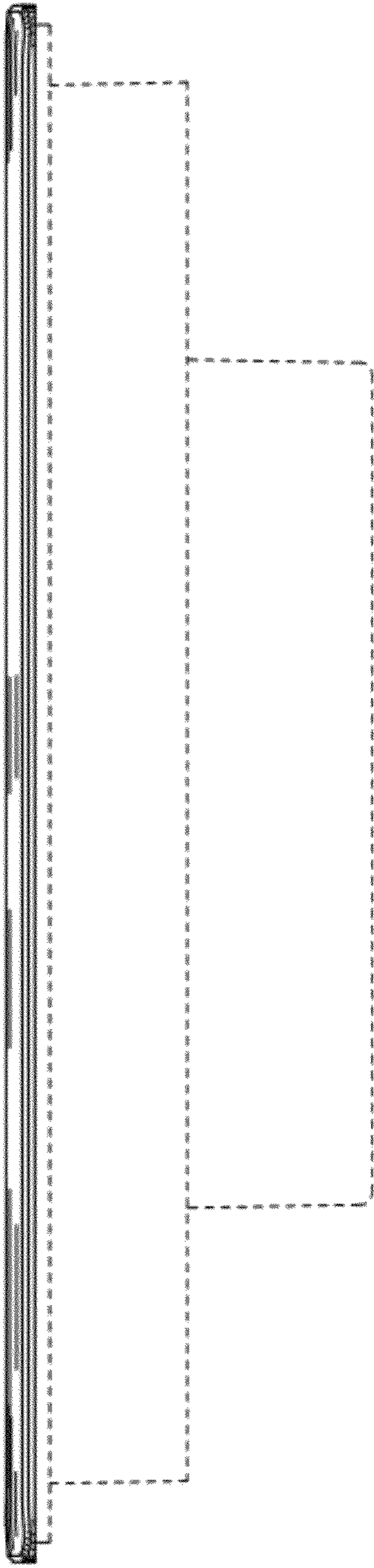

Fig. 7

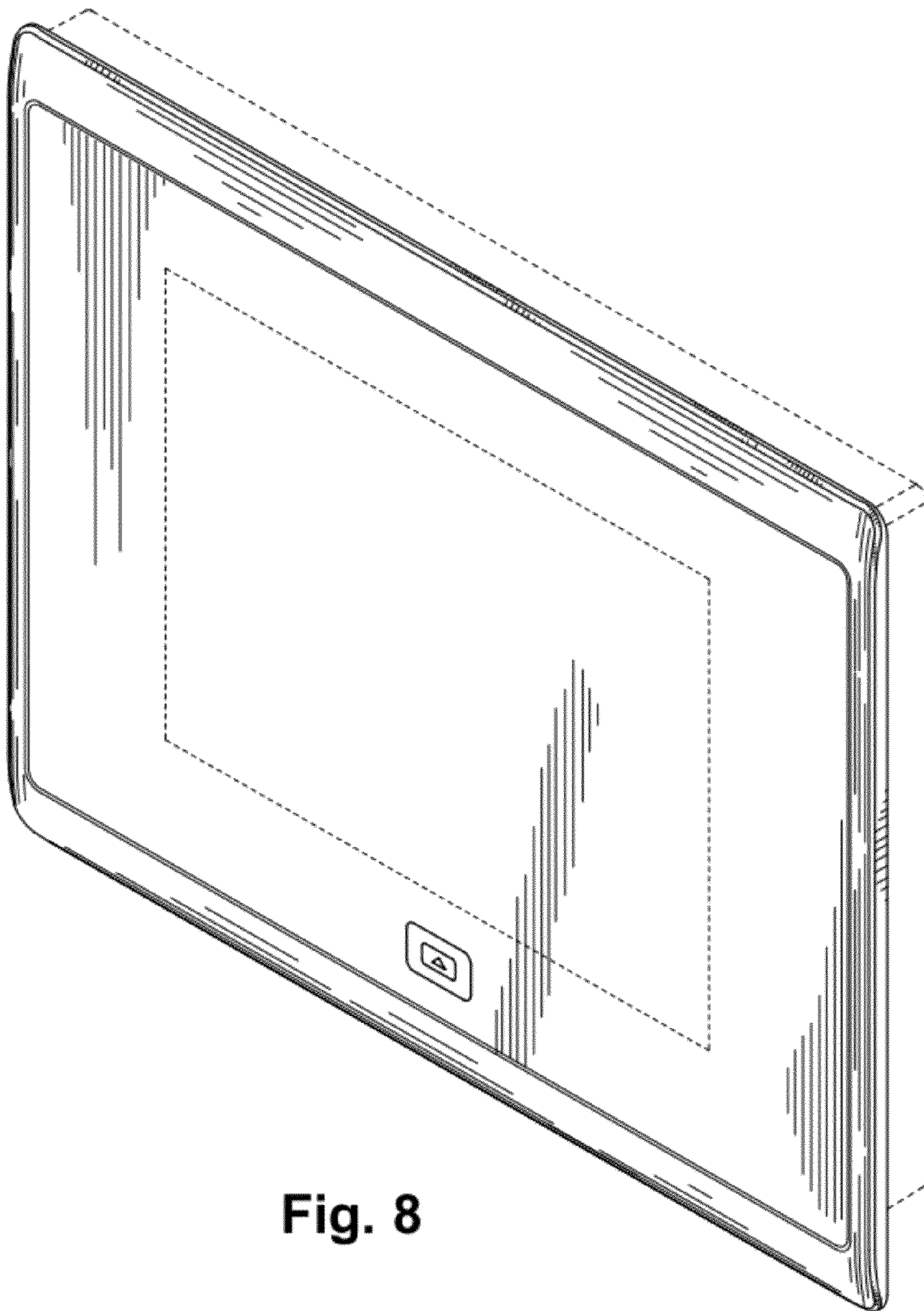

Fig. 8

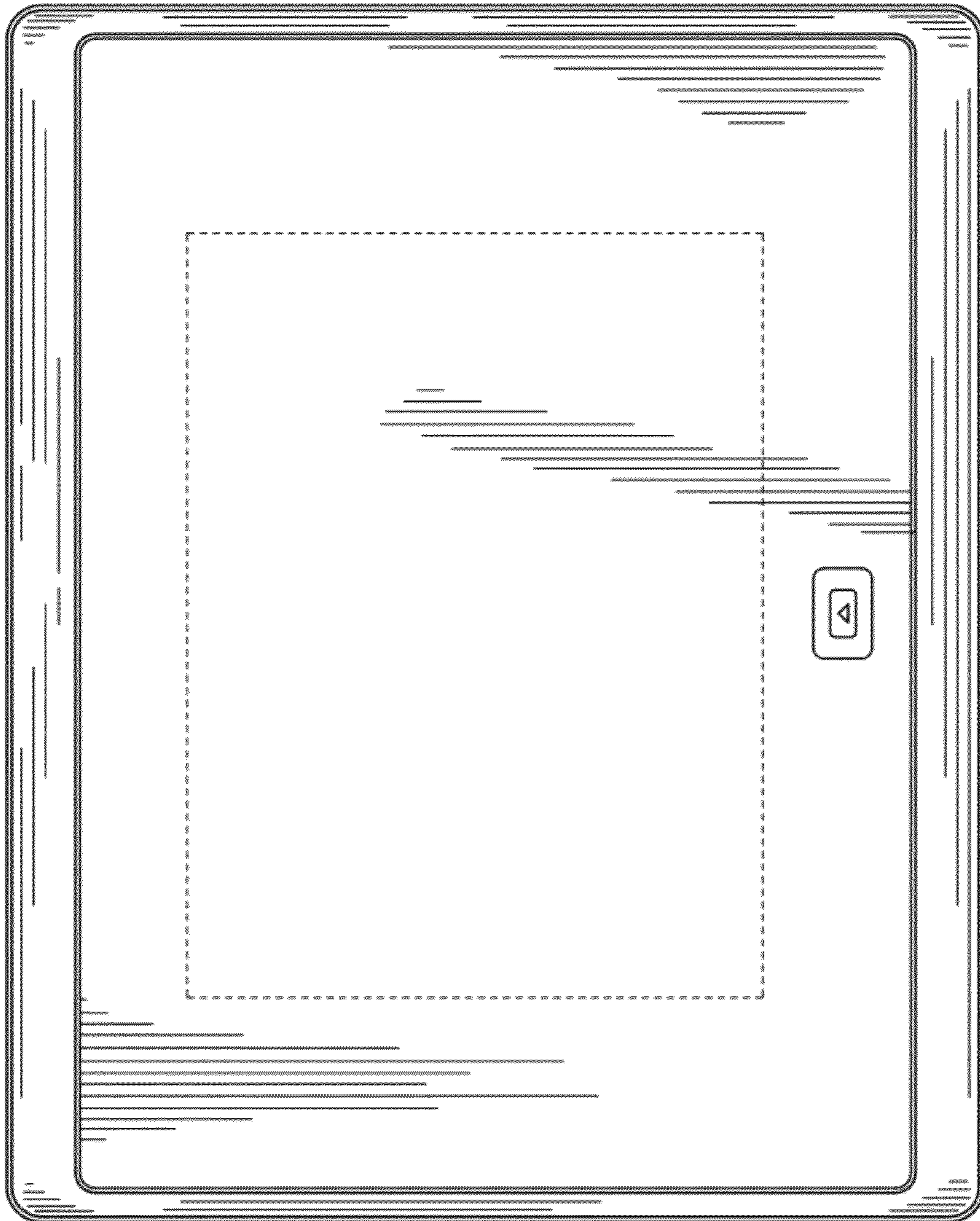

Fig. 9

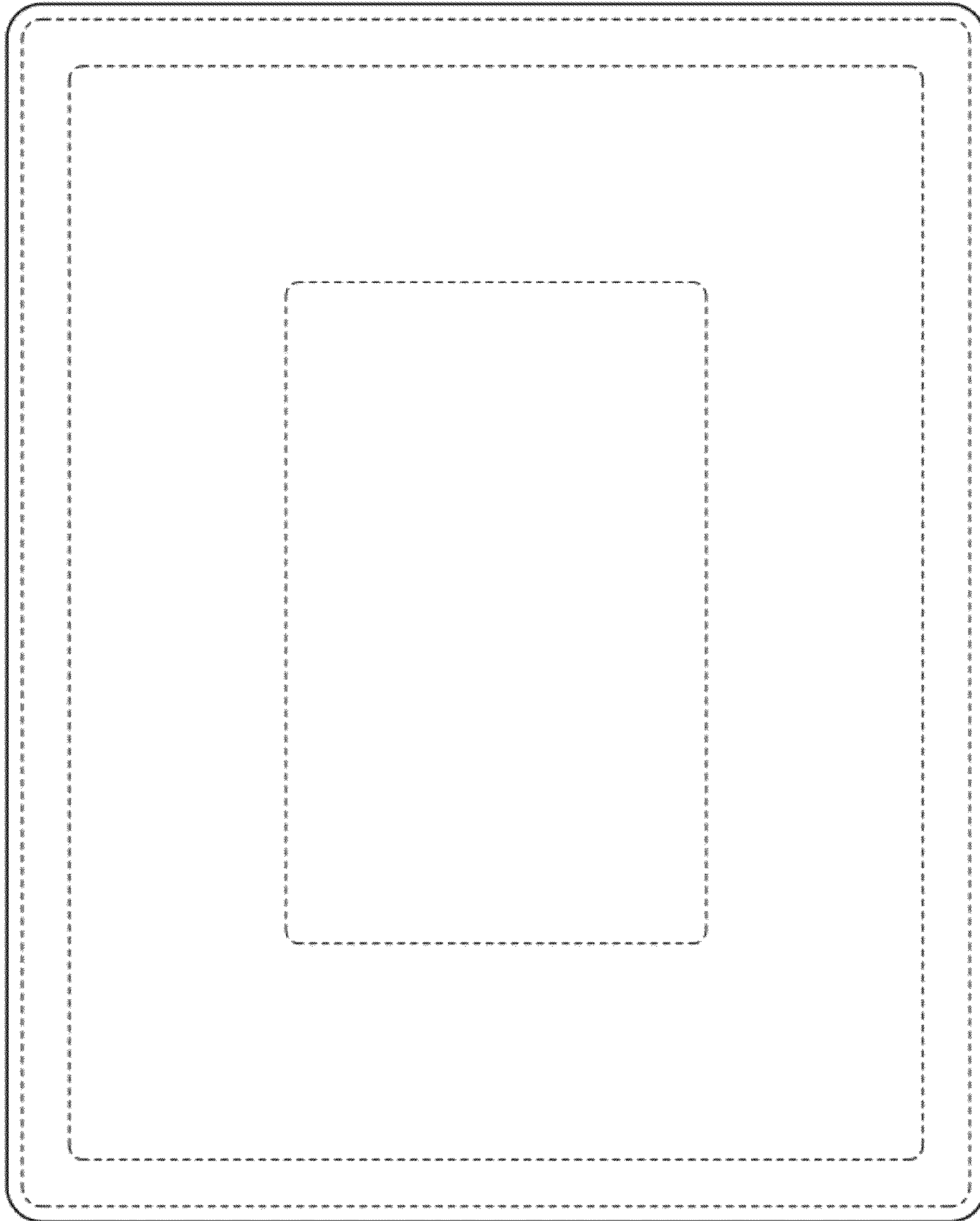

Fig. 10

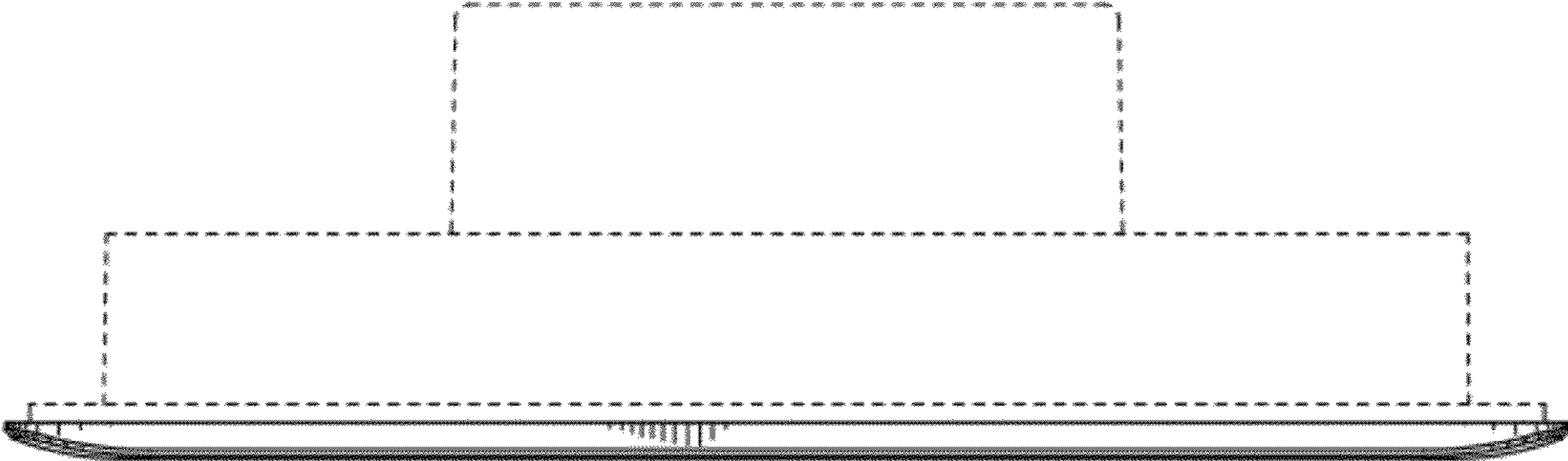

Fig. 12

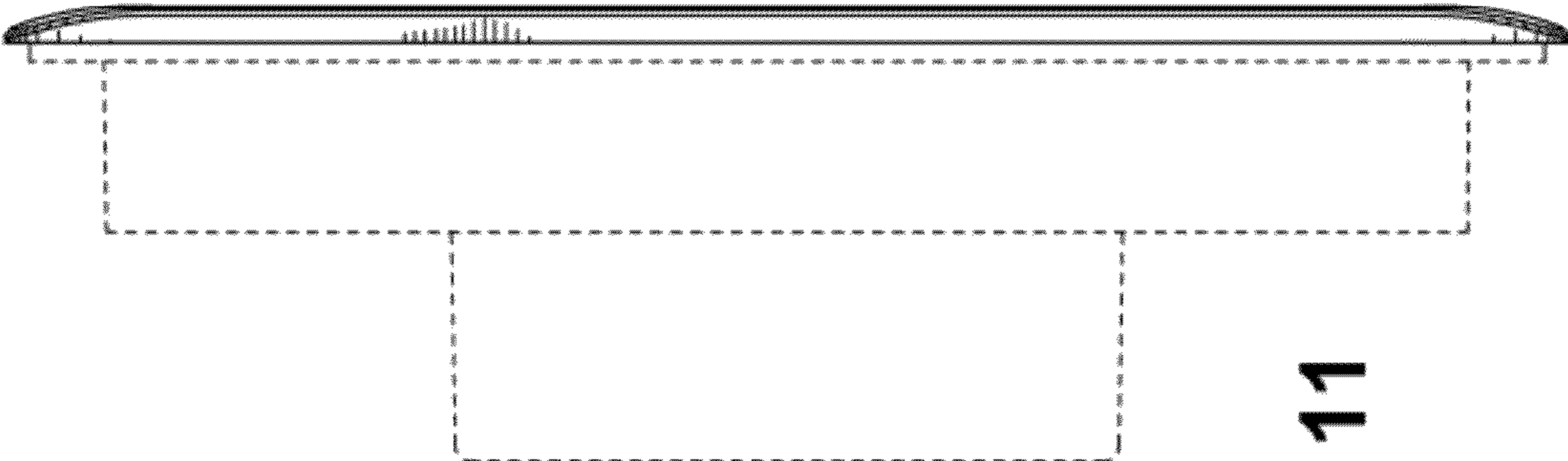

Fig. 11

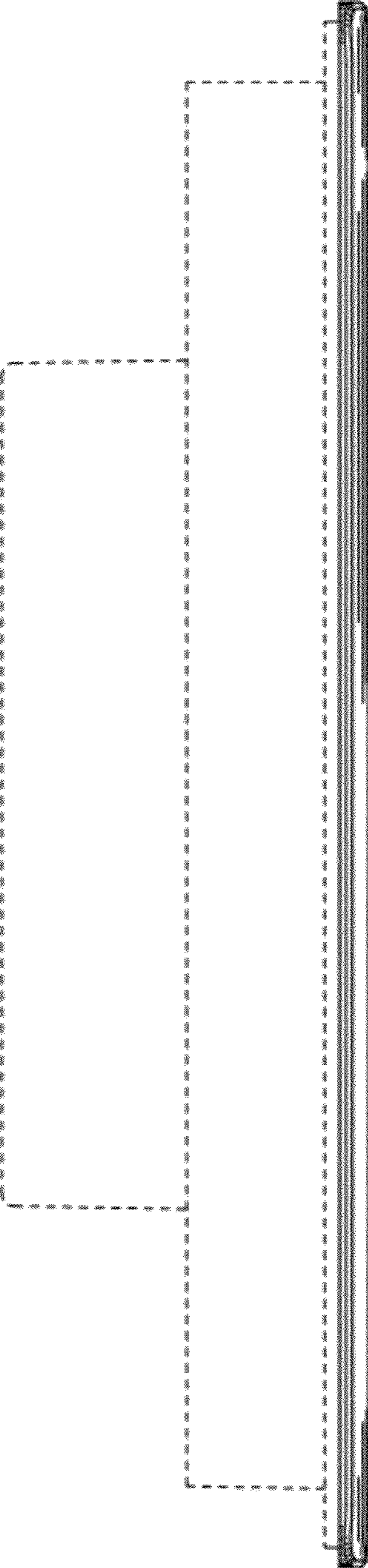

Fig. 13

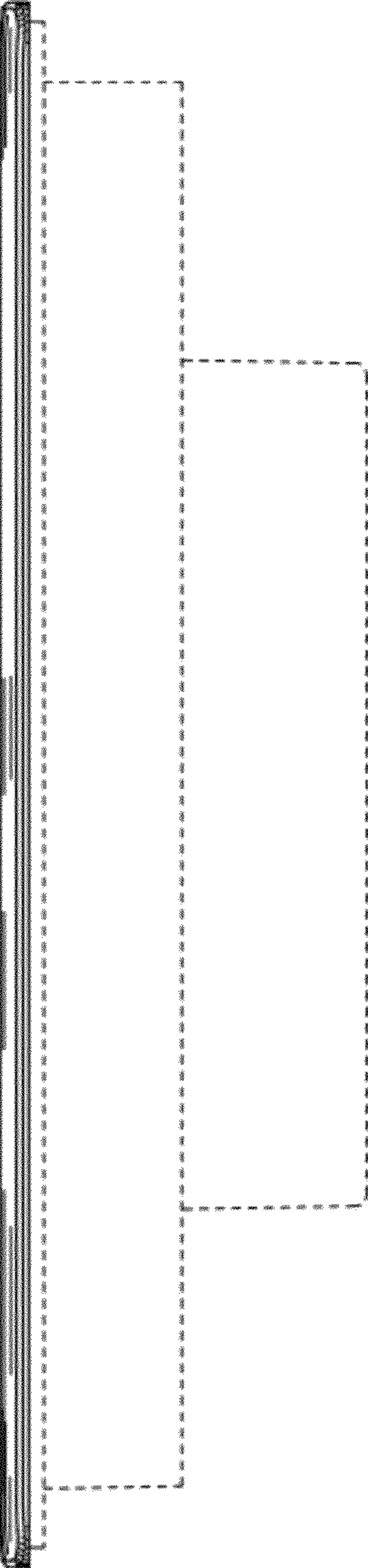

Fig. 14

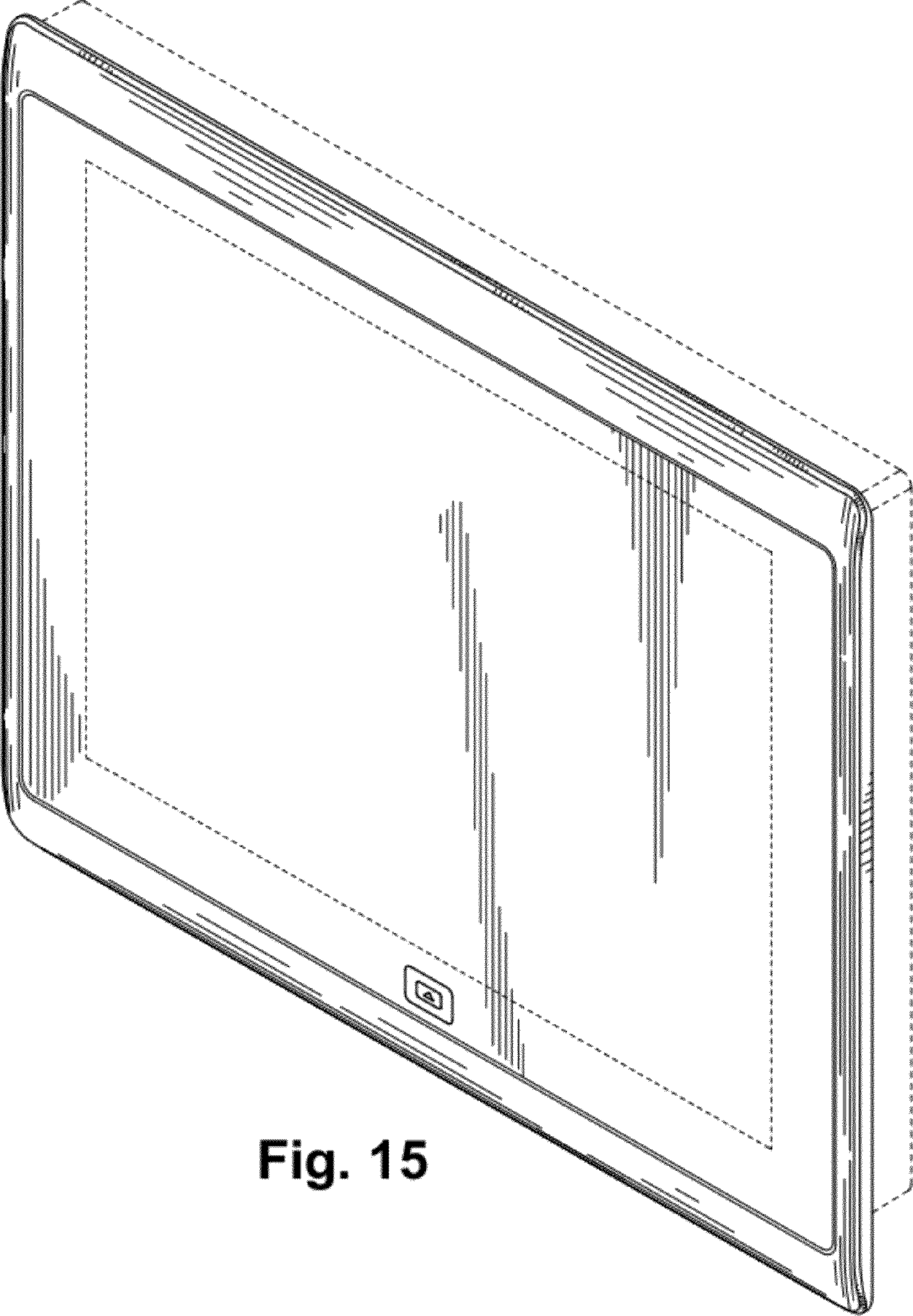

Fig. 15

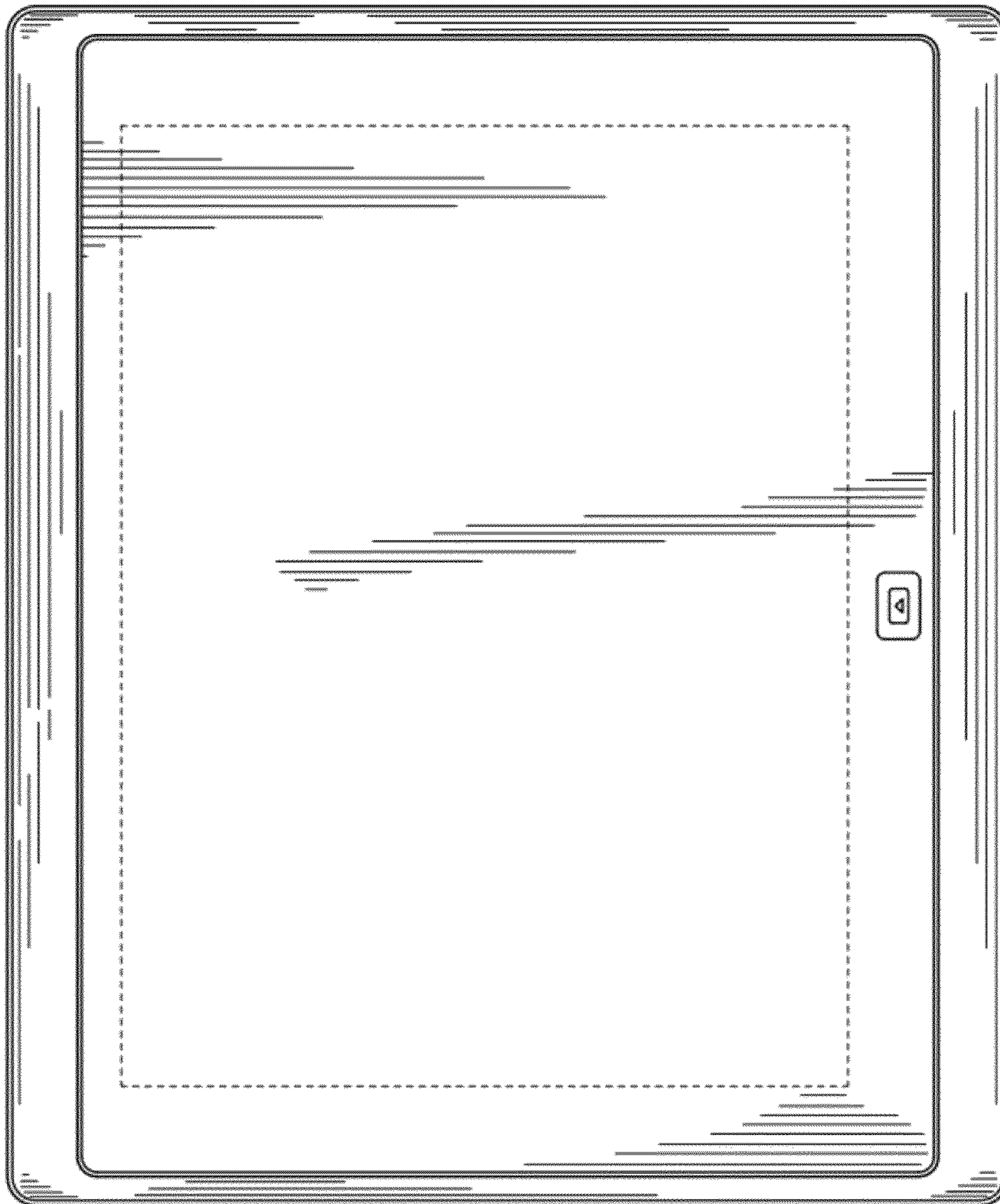

Fig. 16

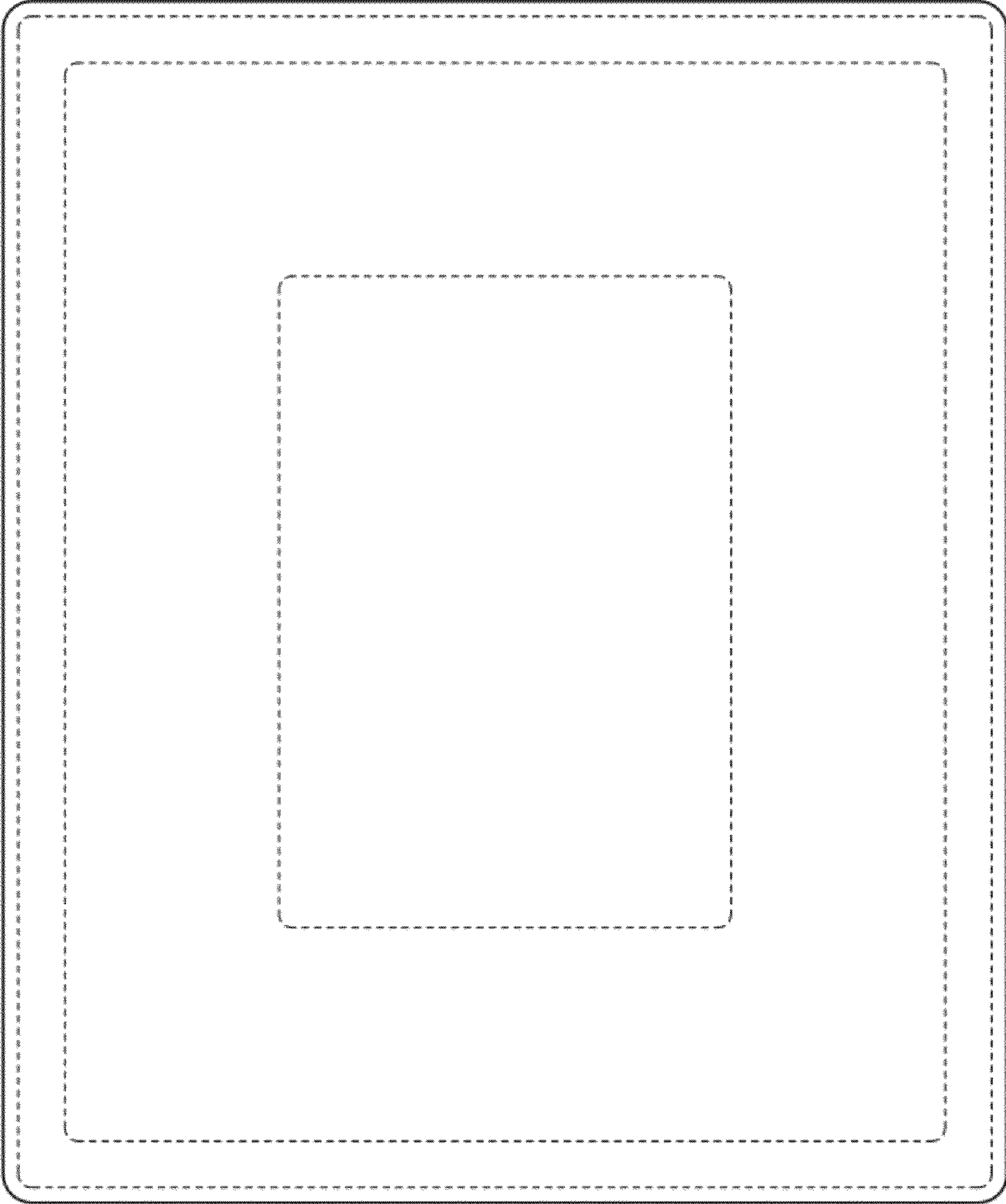

Fig. 17

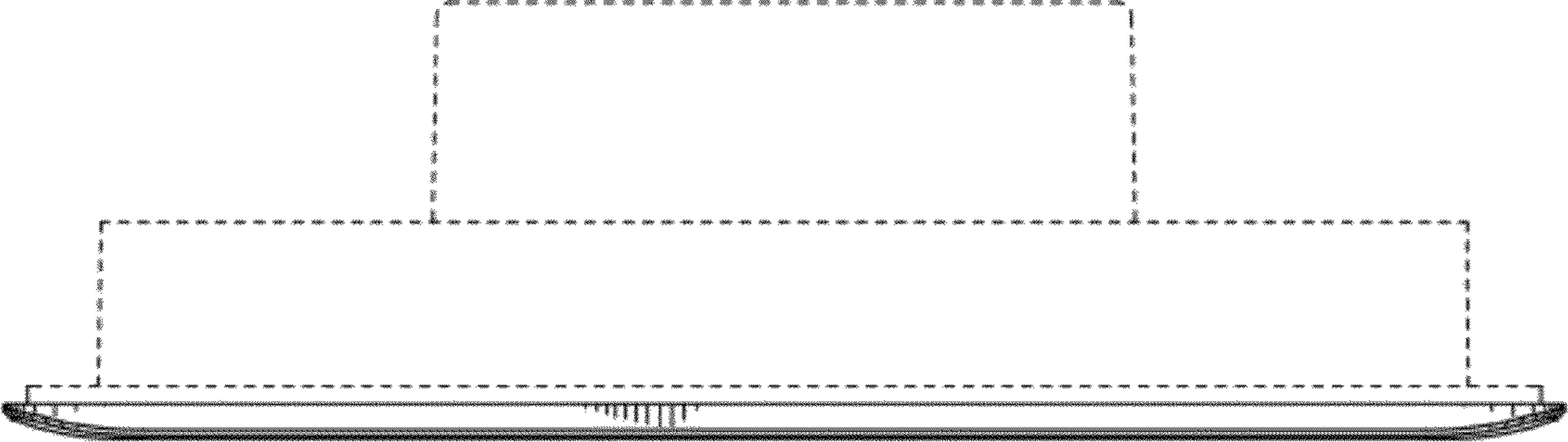

Fig. 19

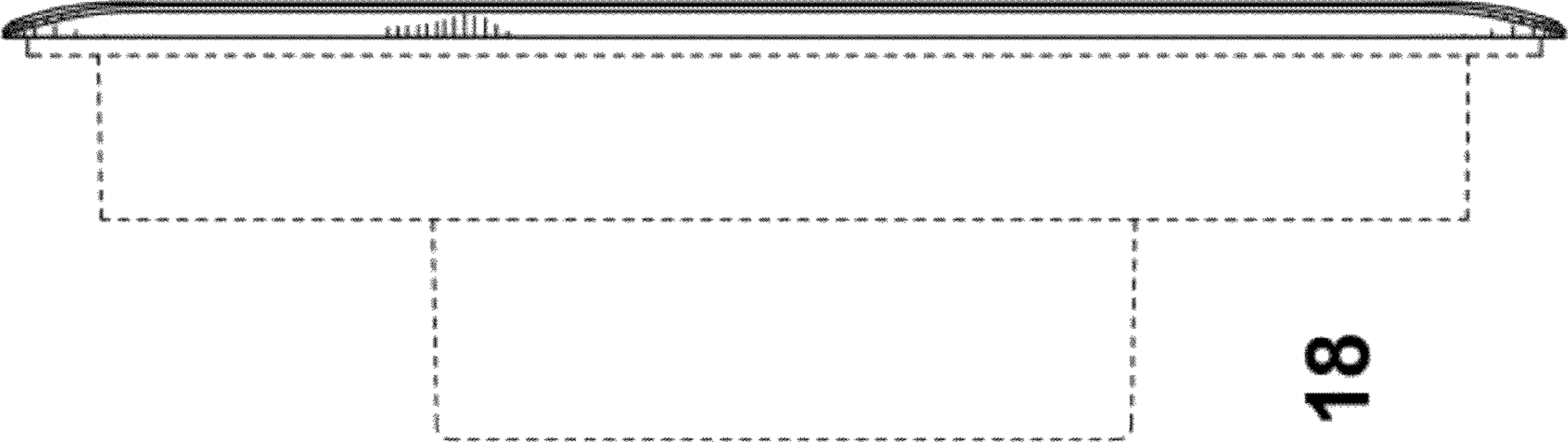

Fig. 18

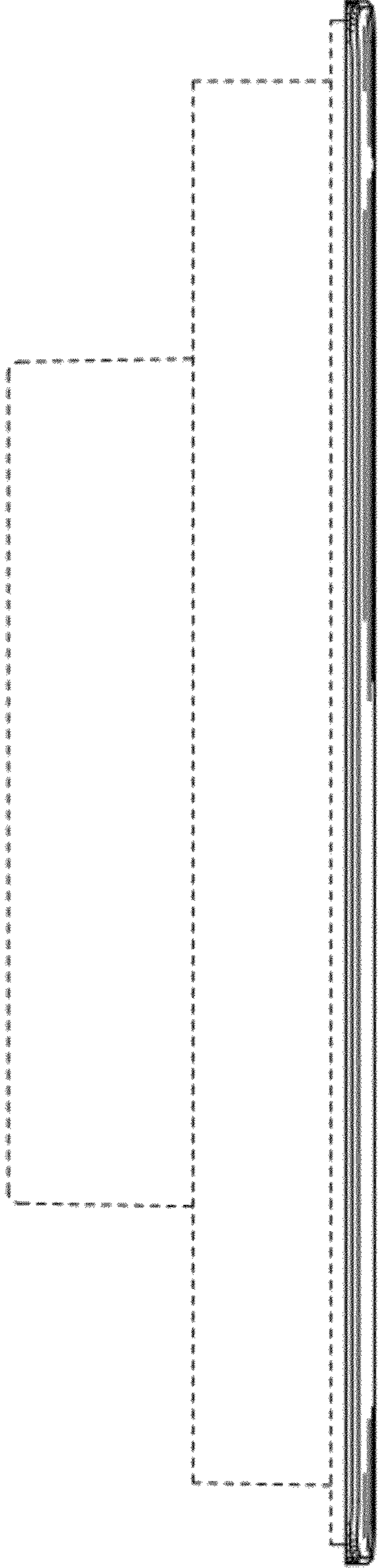

Fig. 20

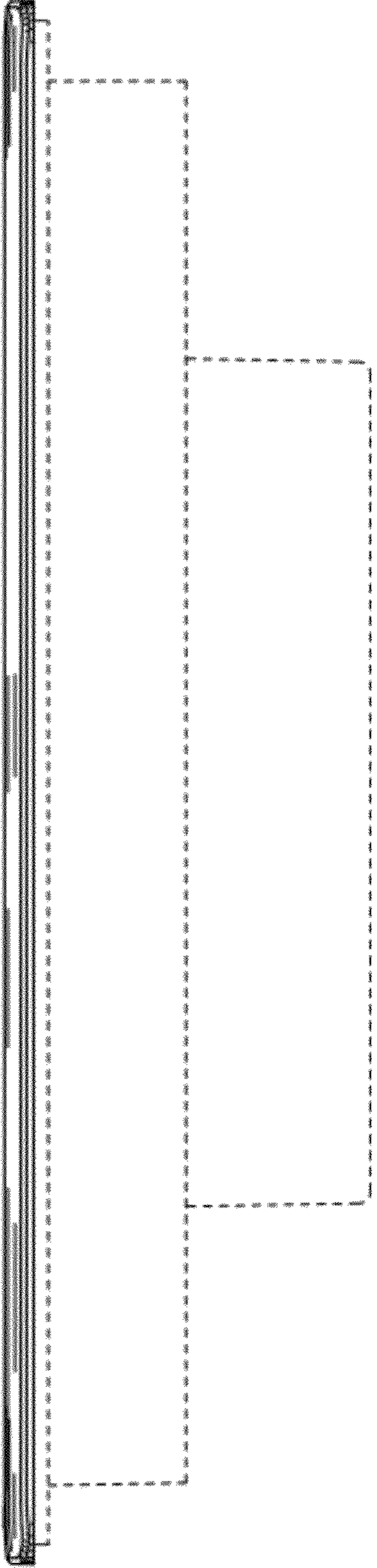

Fig. 21

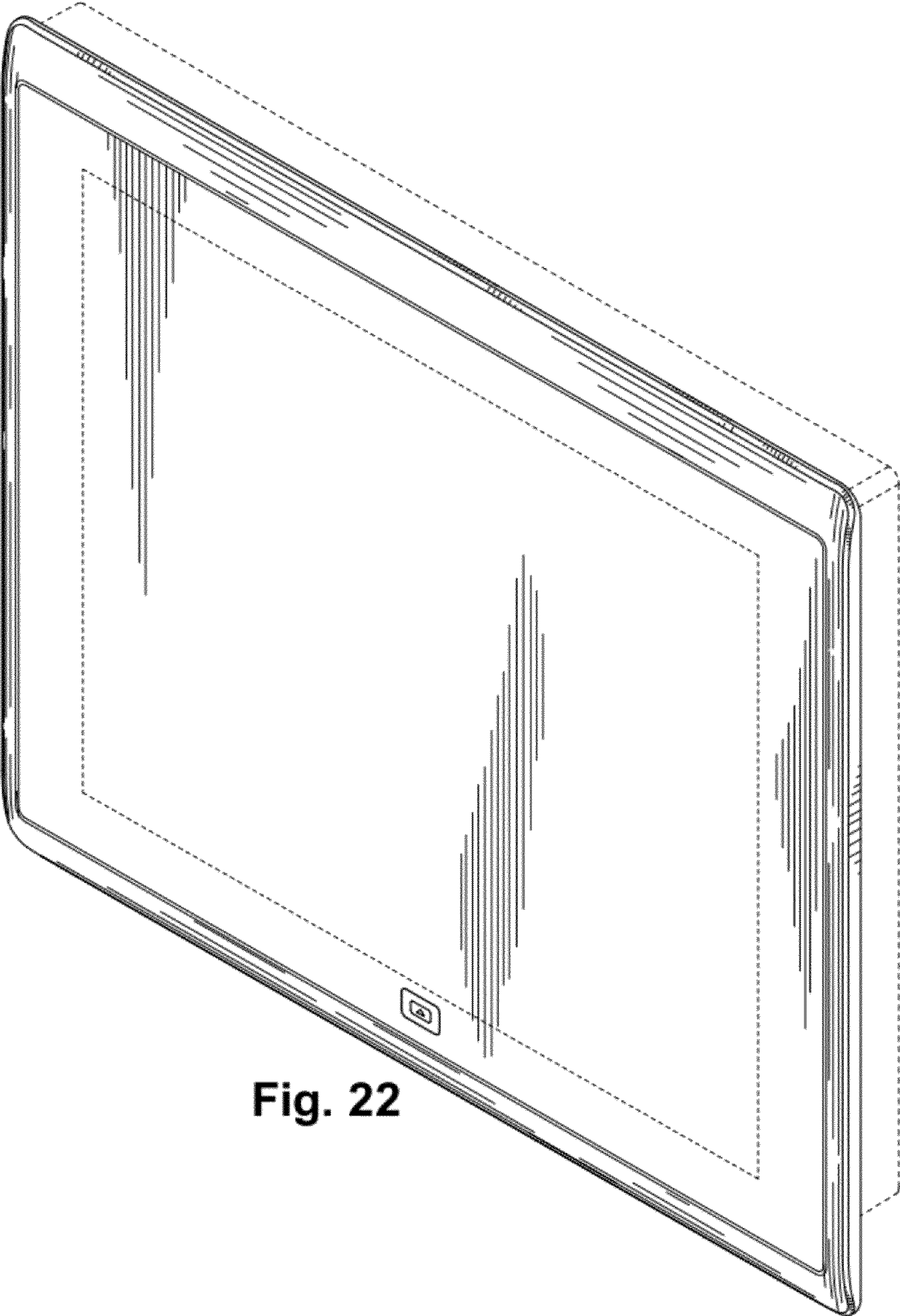

Fig. 22

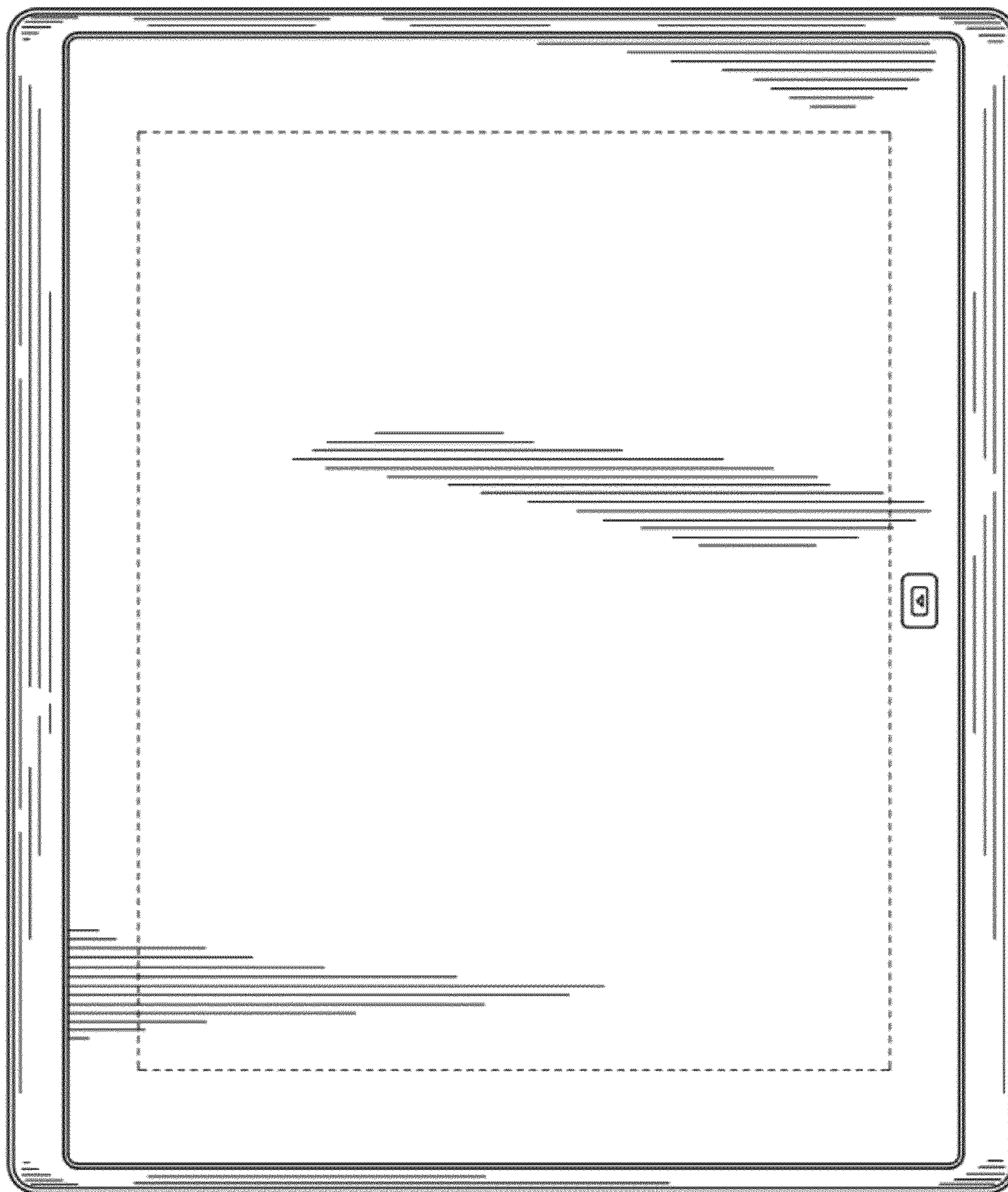

Fig. 23

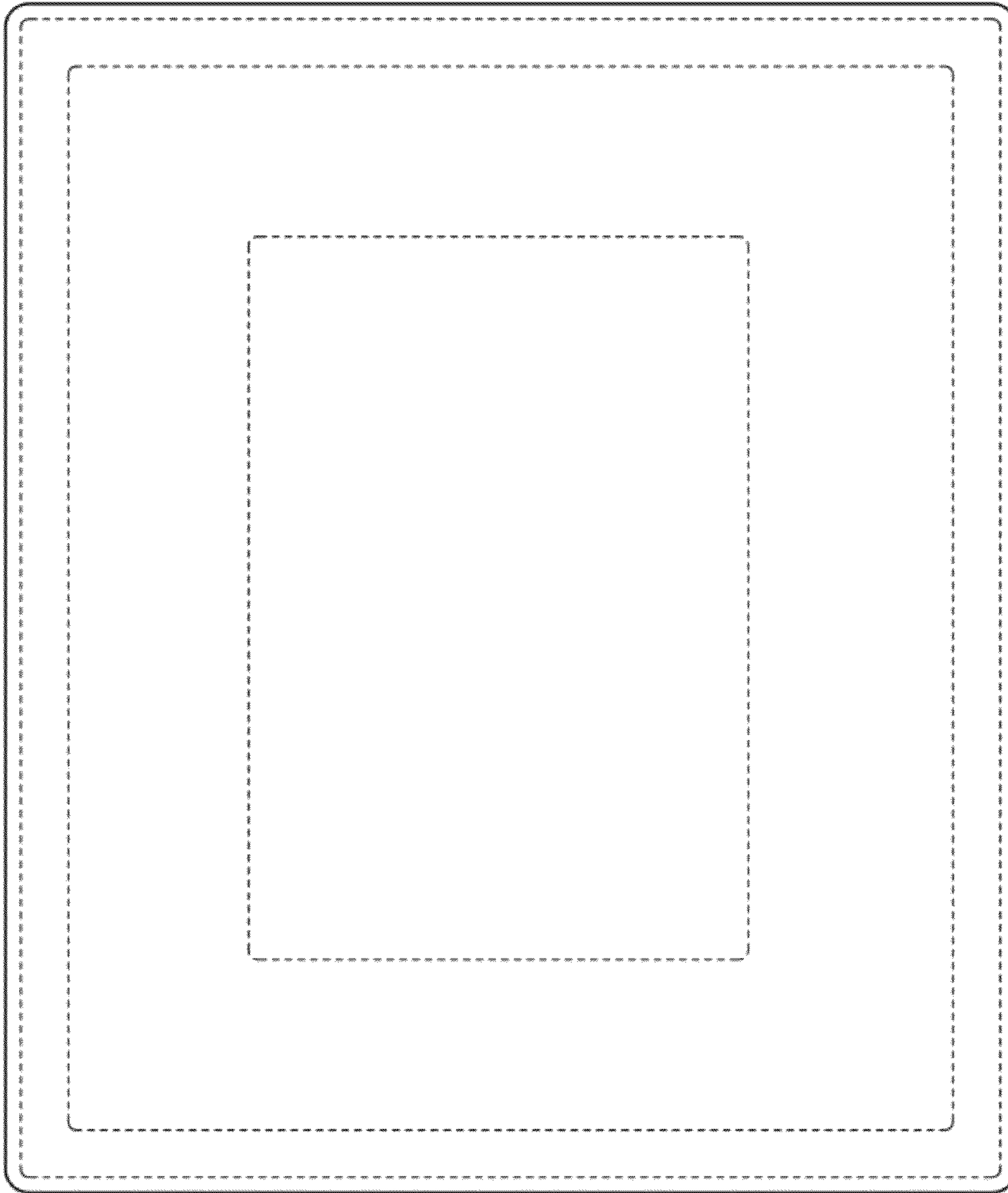

Fig. 24

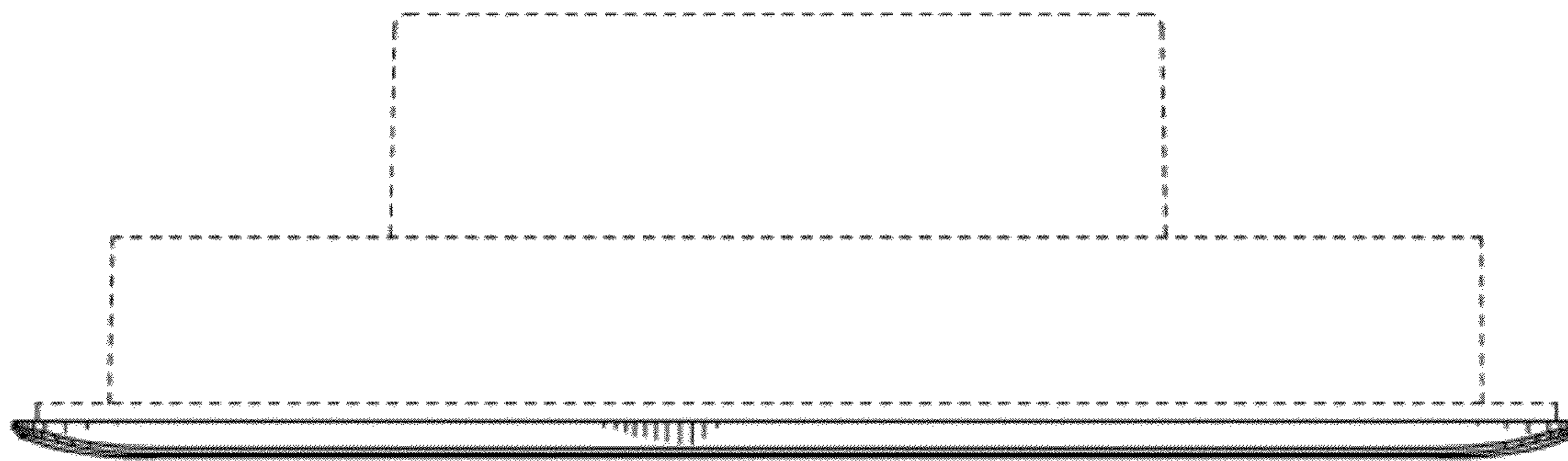

Fig. 26

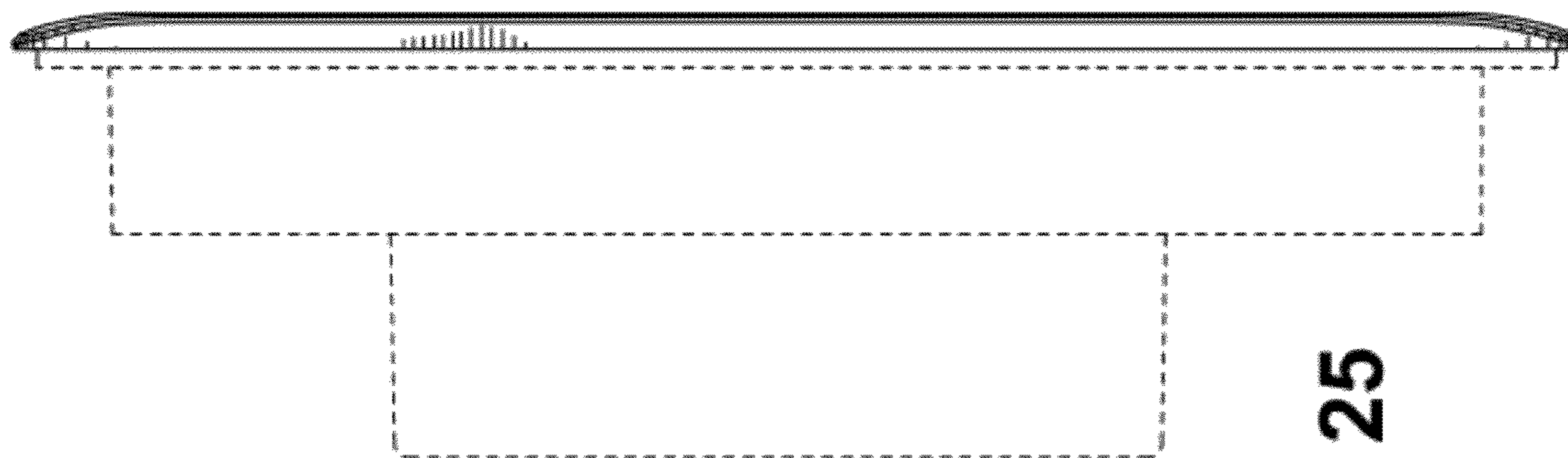

Fig. 25

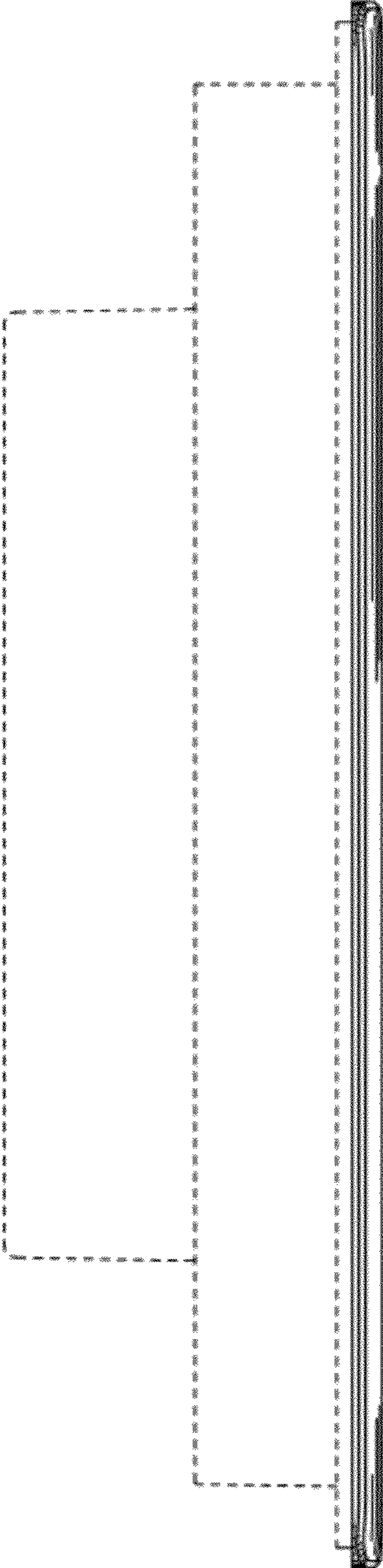

Fig. 27

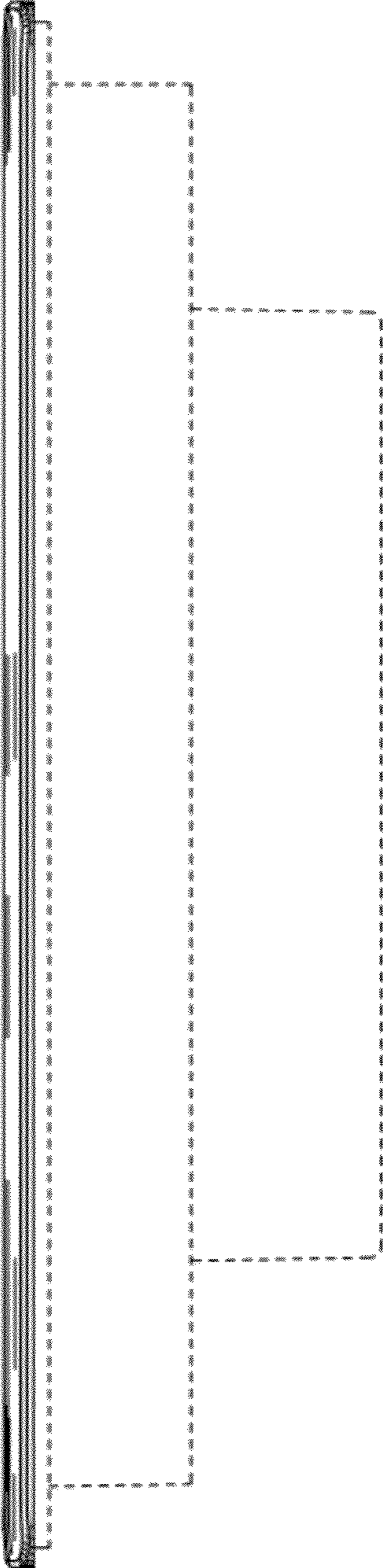

Fig. 28

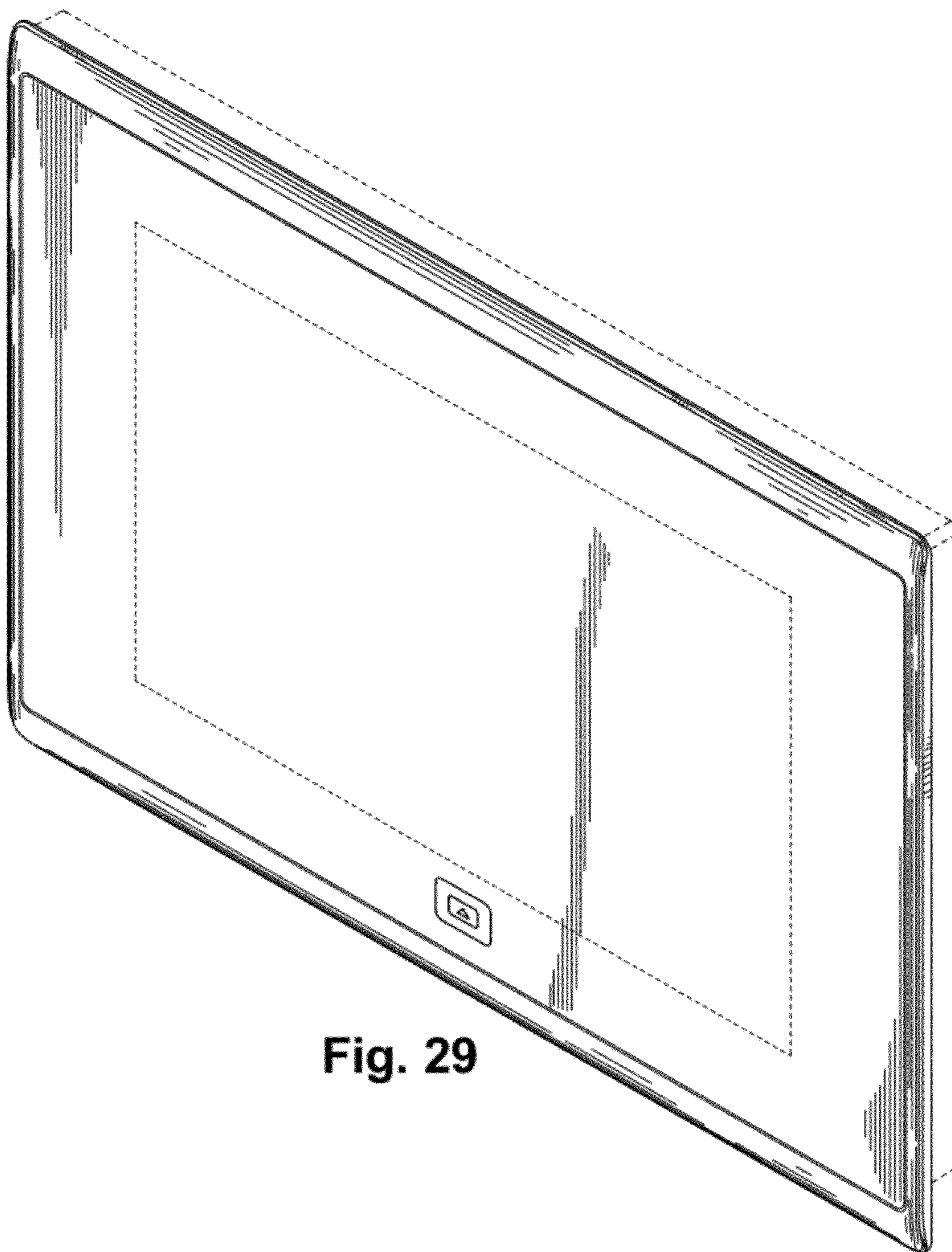

Fig. 29

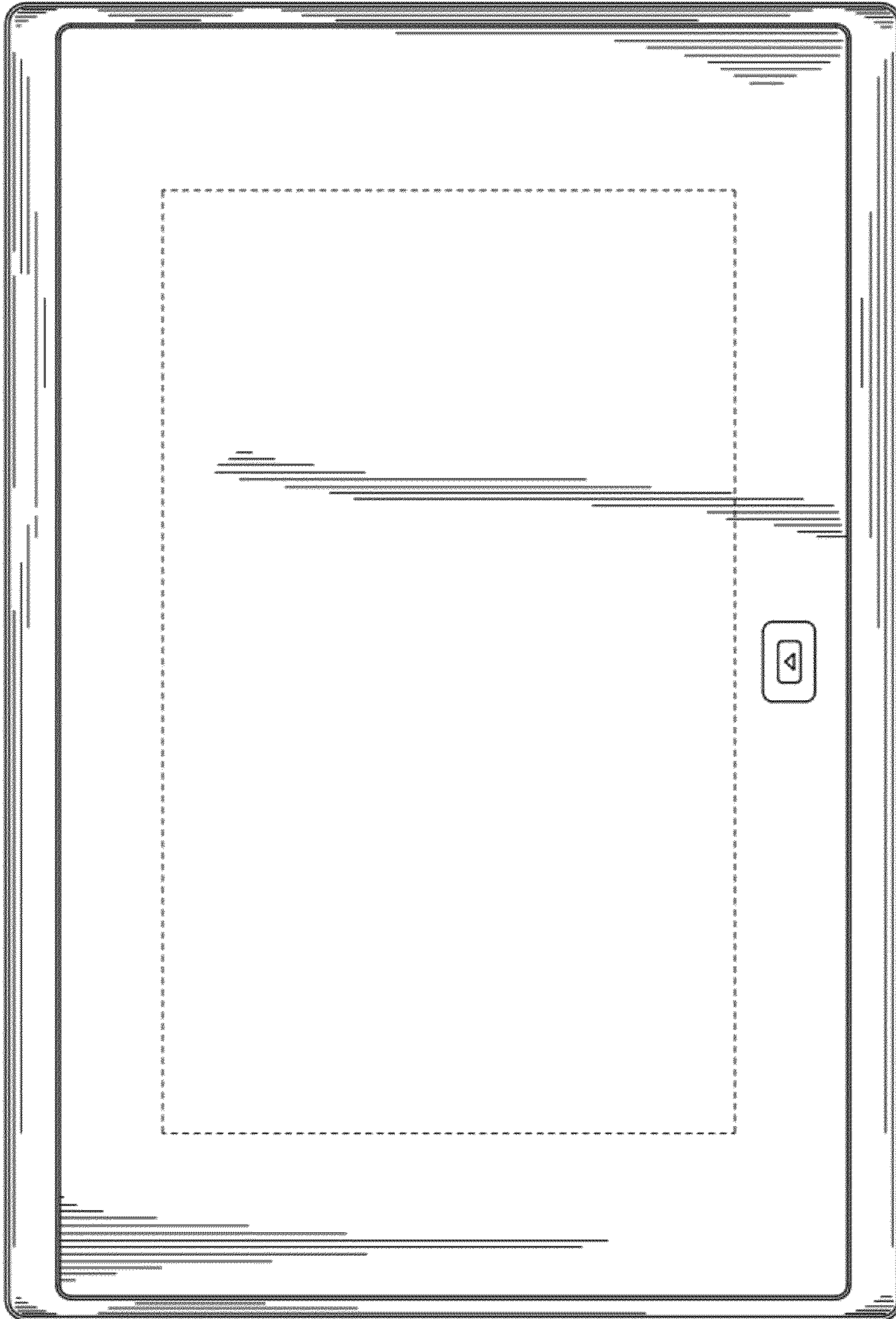

Fig. 30

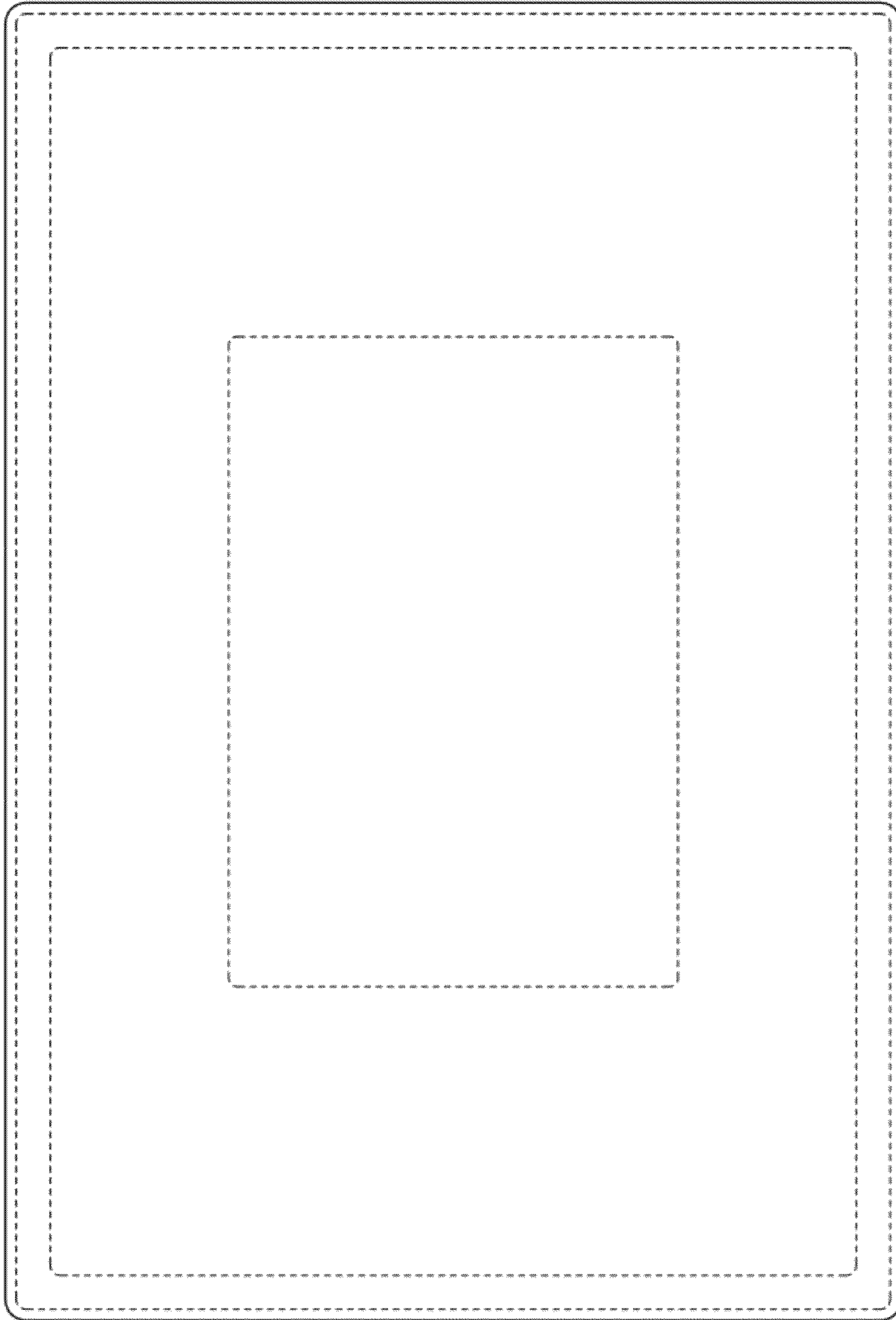

Fig. 31

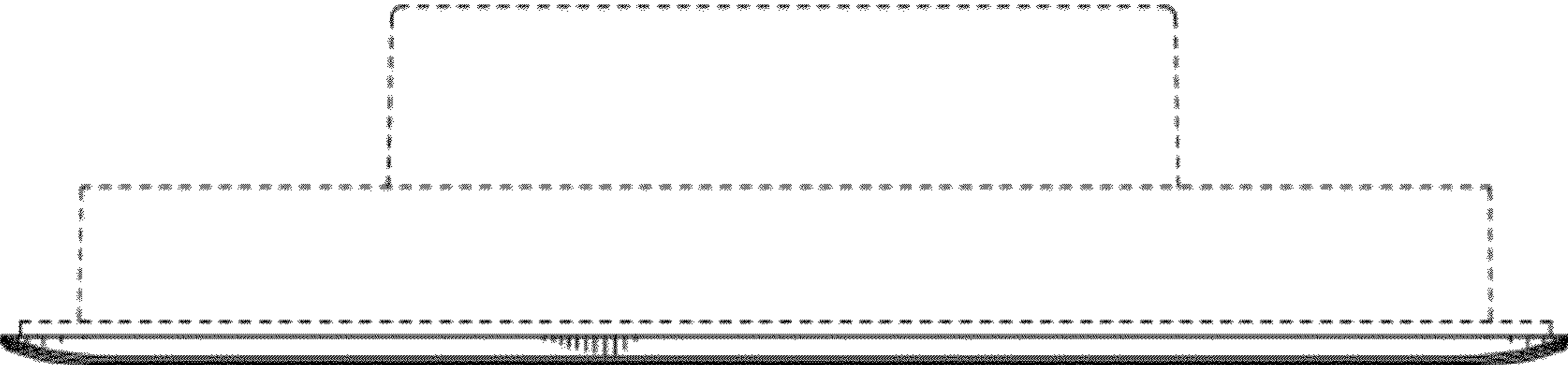

Fig. 33

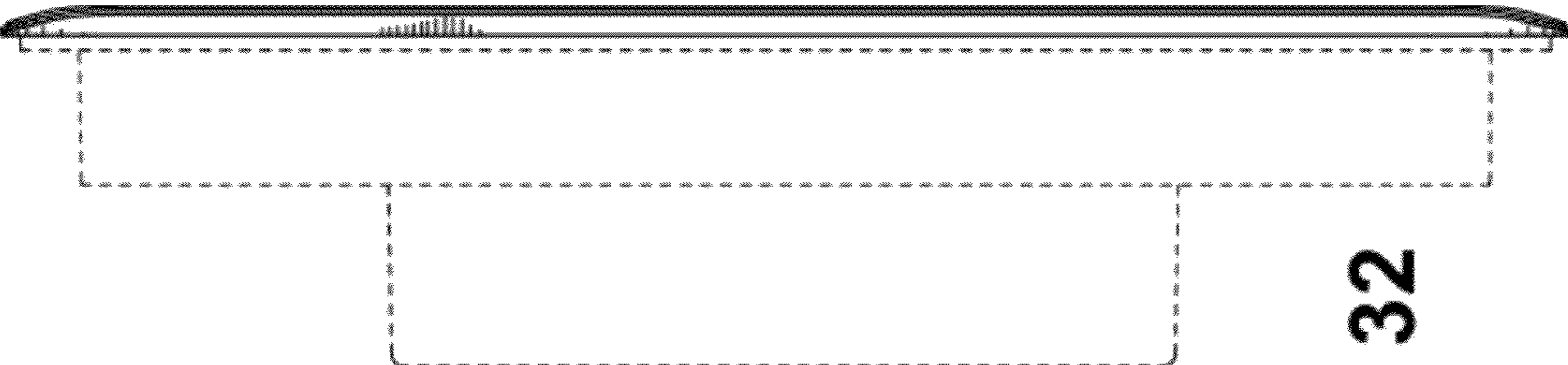

Fig. 32

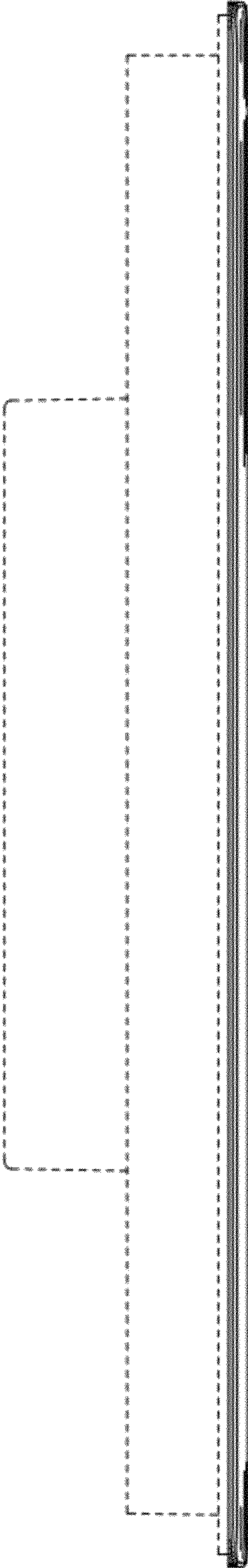

Fig. 34

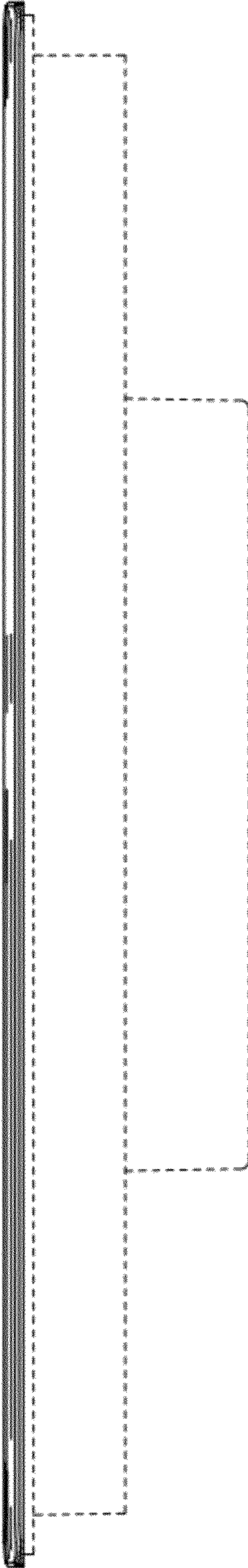

Fig. 35

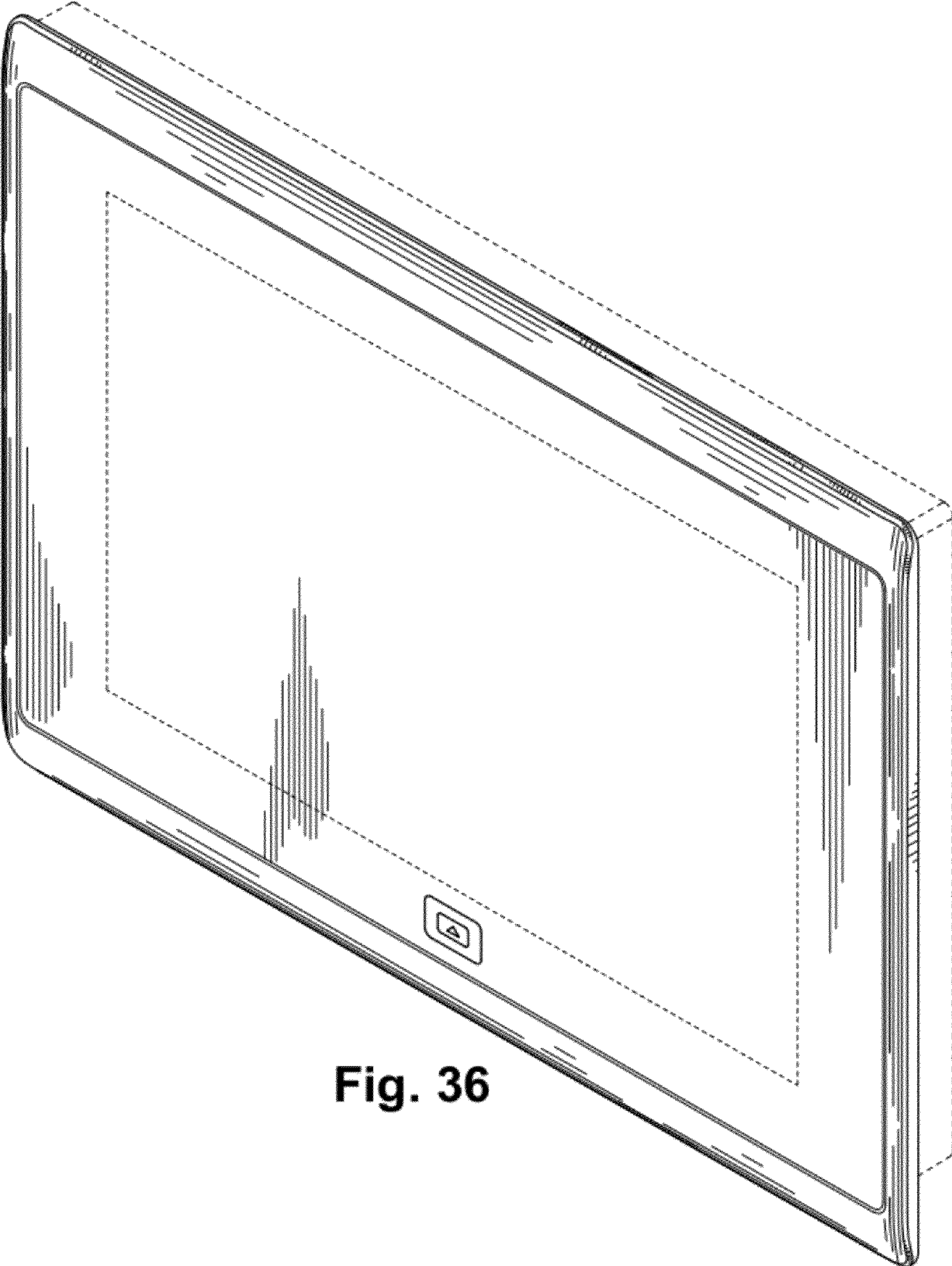

Fig. 36

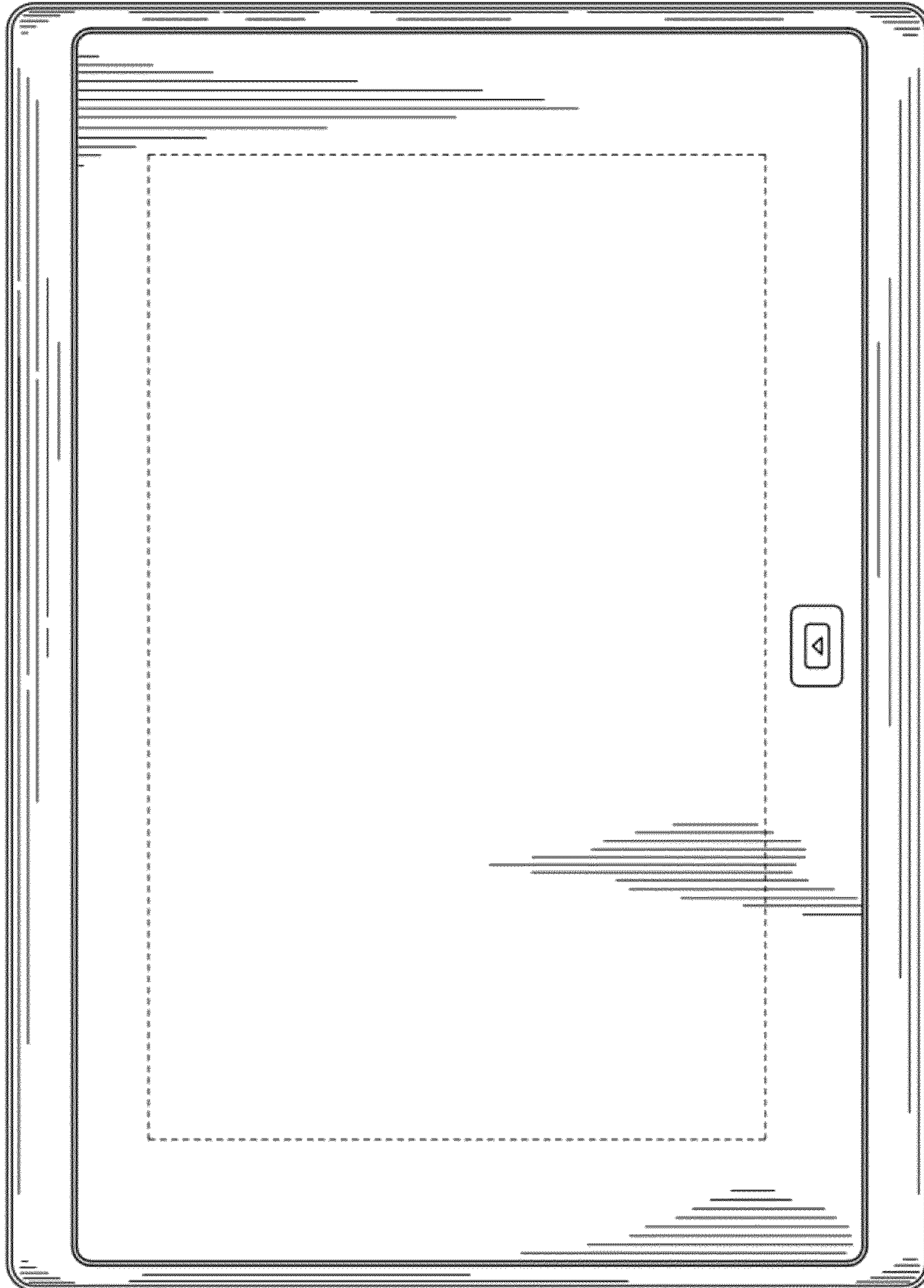

Fig. 37

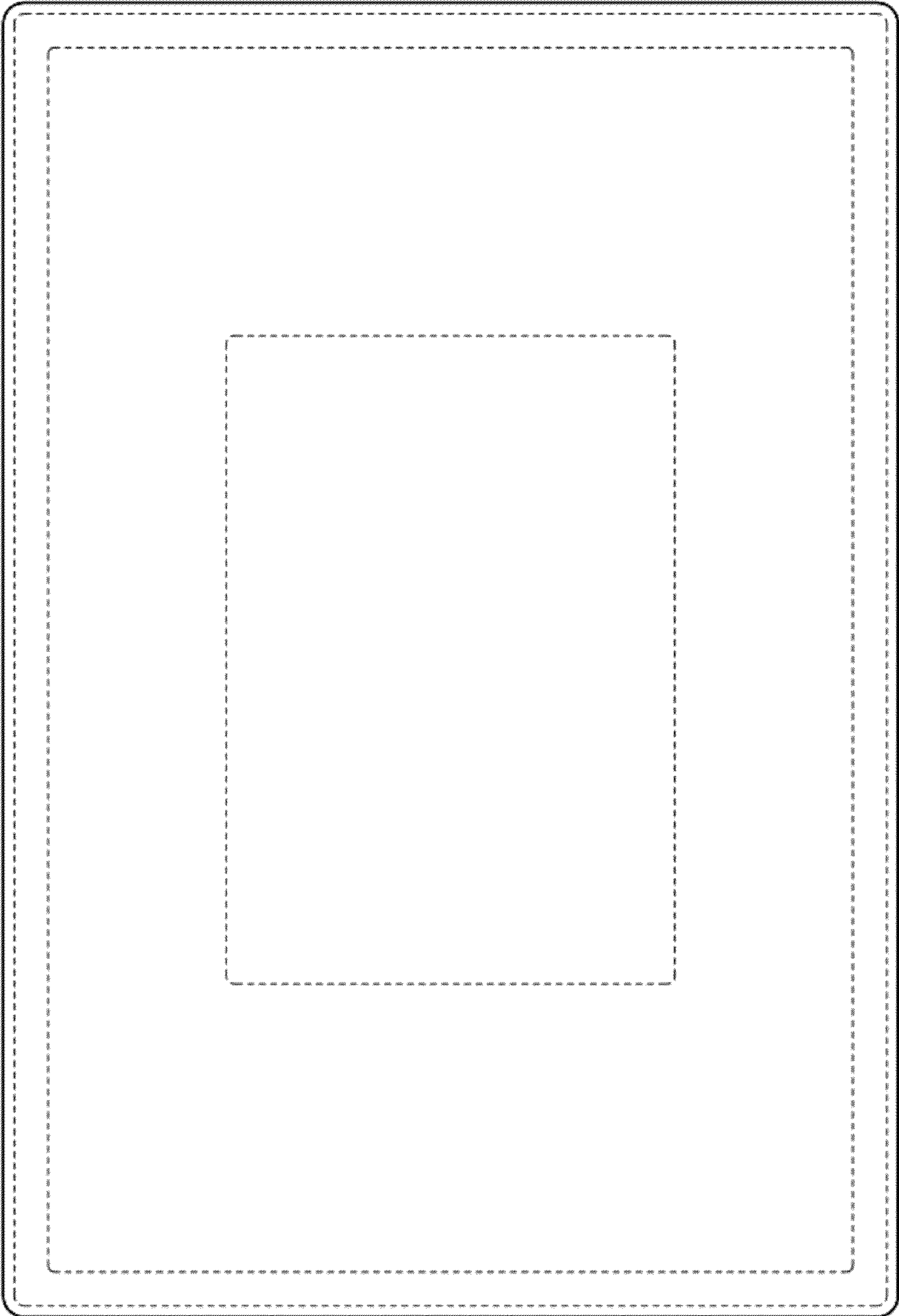

Fig. 38

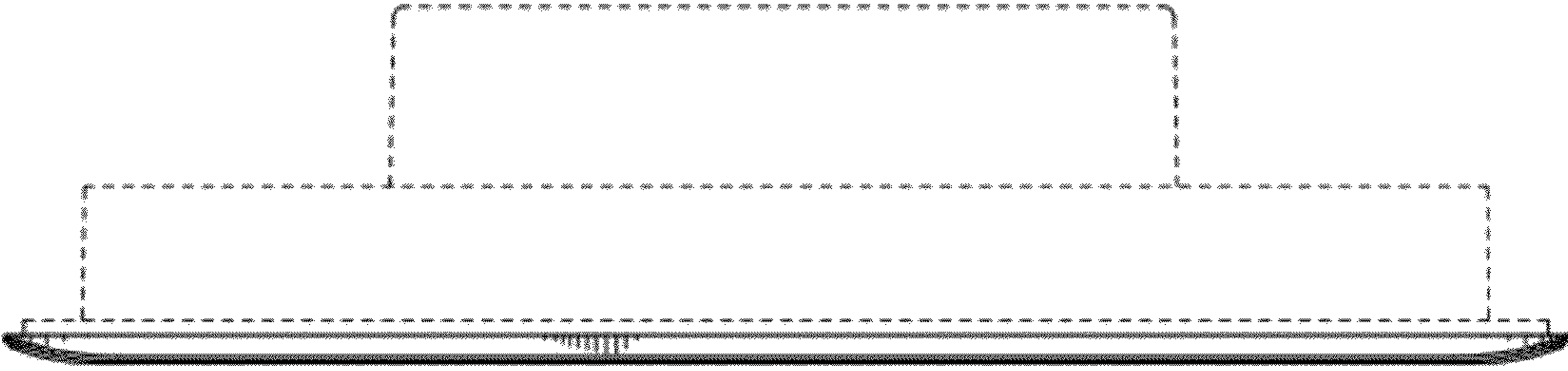

Fig. 40



Fig. 39

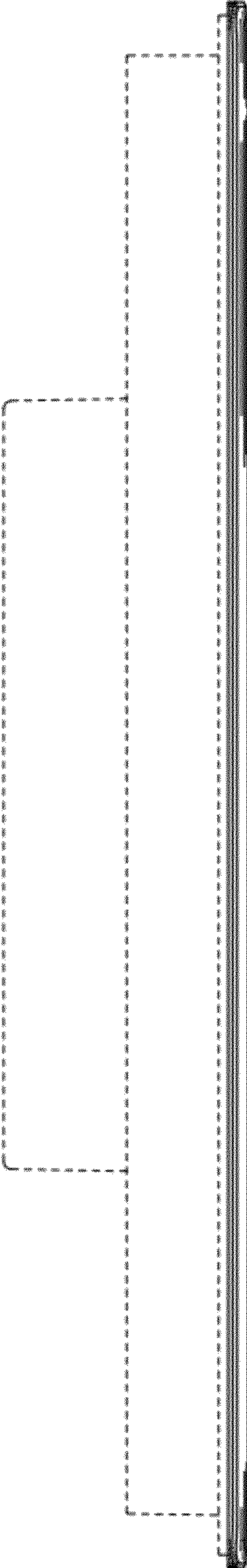

Fig. 41

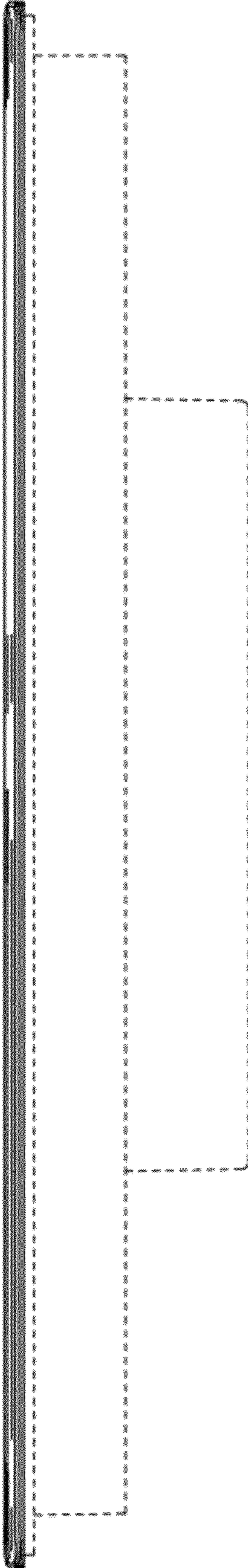

Fig. 42