

US00D661714S

(12) **United States Design Patent**  
**Waterhouse et al.**

(10) **Patent No.:** **US D661,714 S**  
(45) **Date of Patent:** **\*\* Jun. 12, 2012**

(54) **PORTABLE PLURAL COMPONENT  
PROPORTIONER**

(75) Inventors: **Tryg E. Waterhouse**, Chanhassen, MN  
(US); **Martin P. McCormick**, Forest  
Lake, MN (US); **Ryan F. Butler**,  
Brooklyn Park, MN (US)

(73) Assignee: **Graco Minnesota Inc.**, Minneapolis,  
MN (US)

(\*\*) Term: **14 Years**

(21) Appl. No.: **29/403,466**

(22) Filed: **Oct. 6, 2011**

(51) **LOC (9) Cl.** ..... **15-09**

(52) **U.S. Cl.** ..... **D15/135**

(58) **Field of Classification Search** ..... D15/122,  
D15/124, 135, 136, 150, 199; D23/213,  
D23/225; 118/300, 309, 310, 324; 239/146,  
239/147, 150; 401/48, 195

See application file for complete search history.

(56) **References Cited**

**U.S. PATENT DOCUMENTS**

1,987,649	A *	1/1935	Wertz	.....	134/111
D187,550	S *	3/1960	Hoover	.....	D15/150
3,940,065	A *	2/1976	Ware et al.	.....	239/146
D284,210	S *	6/1986	Rattray et al.	.....	D23/225
5,441,297	A *	8/1995	Krohn et al.	.....	280/655
D560,271	S *	1/2008	Kesti et al.	.....	D23/225
D576,703	S *	9/2008	Nathan et al.	.....	D23/225

D580,517	S *	11/2008	Mattson et al.	.....	D23/225
D580,518	S *	11/2008	Johnson et al.	.....	D23/225
D608,414	S *	1/2010	Legatt et al.	.....	D23/225
D616,065	S *	5/2010	Gundersen et al.	.....	D23/225
D640,718	S *	6/2011	Benson	.....	D15/150

**OTHER PUBLICATIONS**

Graco's Fast-Set Plural Component Equipment and Accessories brochure, see Air-Driven Plural Component Proportioner products on p. 6.

\* cited by examiner

*Primary Examiner* — Patricia Palasik

(74) *Attorney, Agent, or Firm* — Douglas B. Farrow

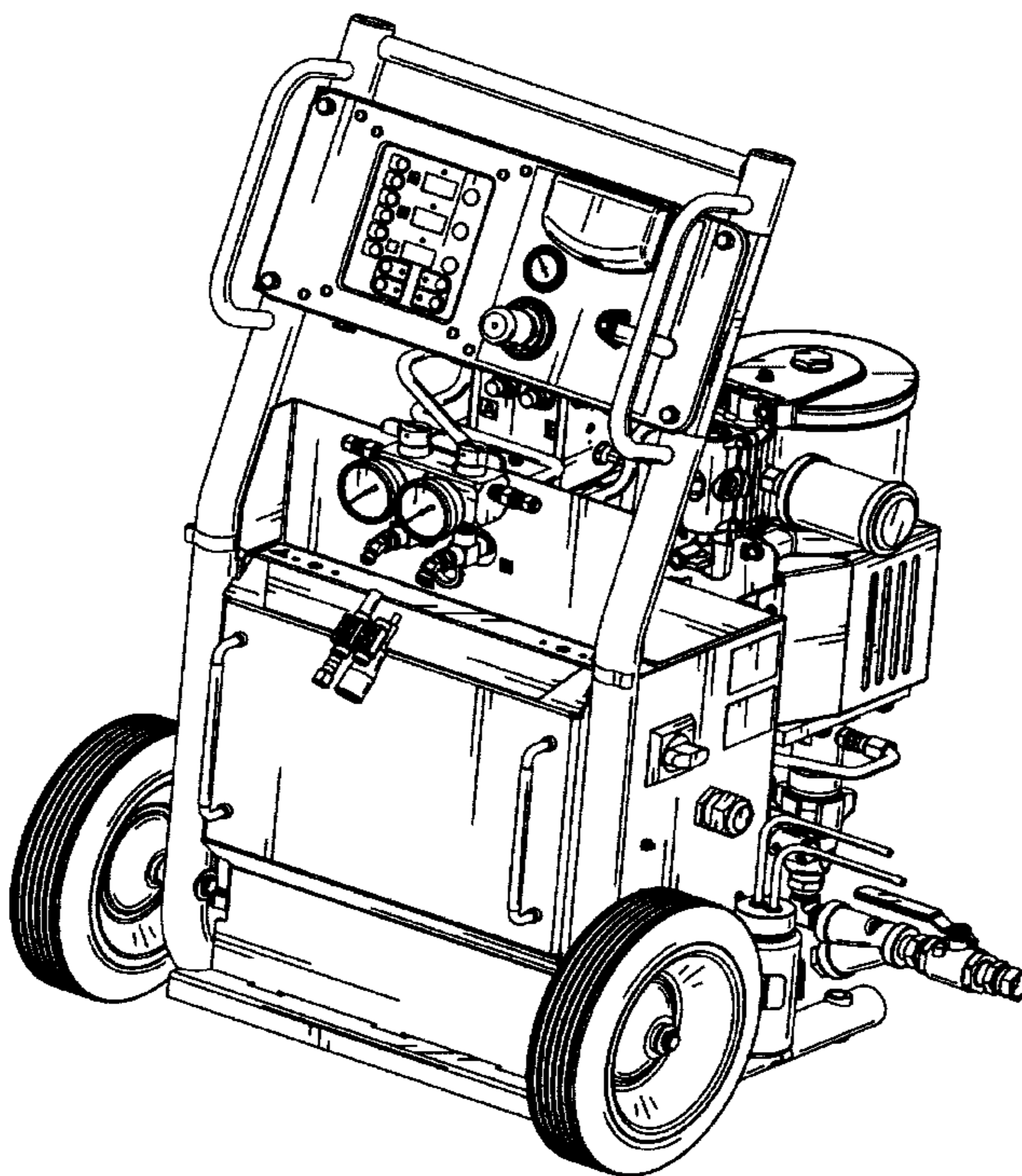
(57) **CLAIM**

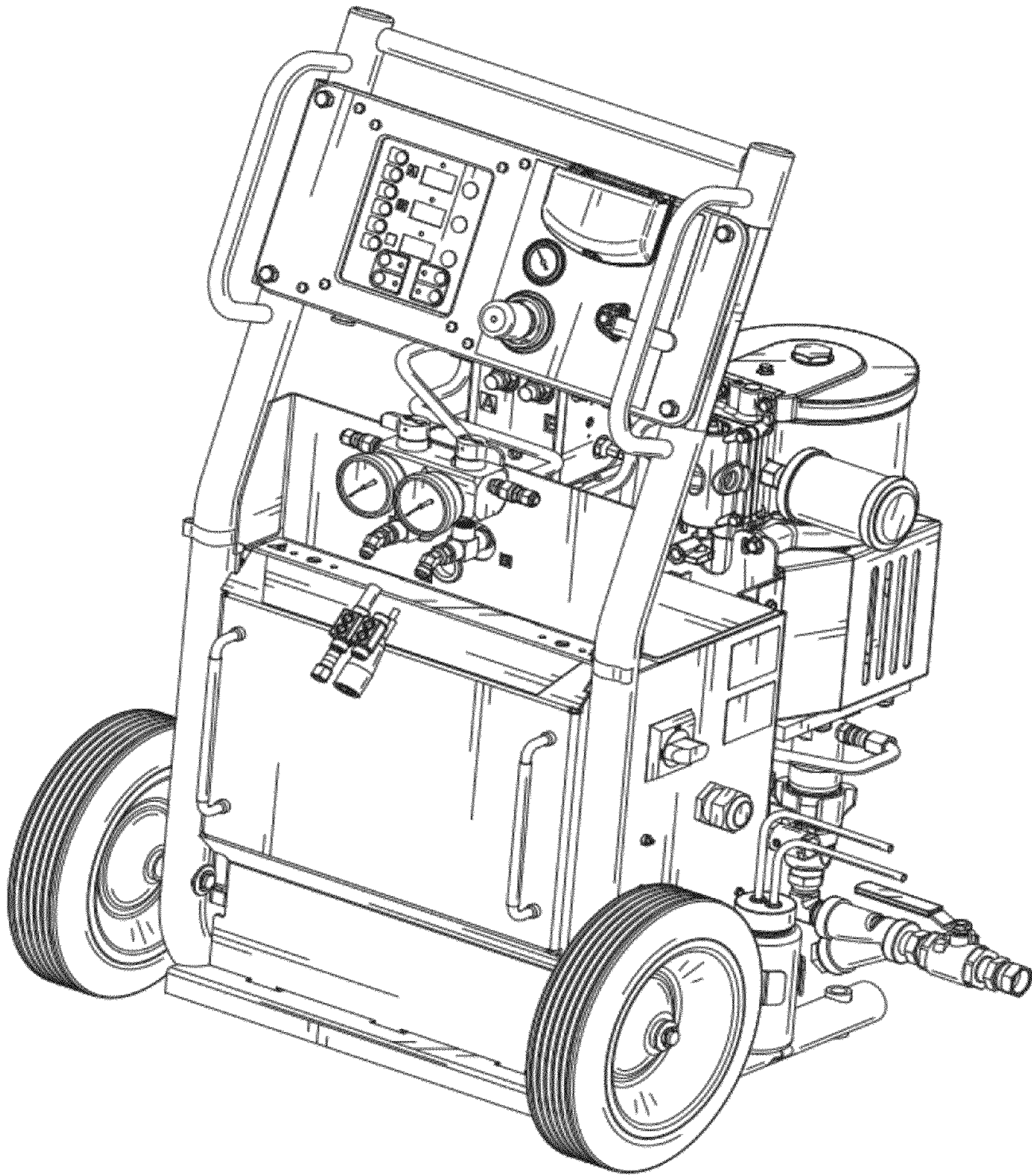
The ornamental design for a portable plural component proportioner, as shown and described.

**DESCRIPTION**

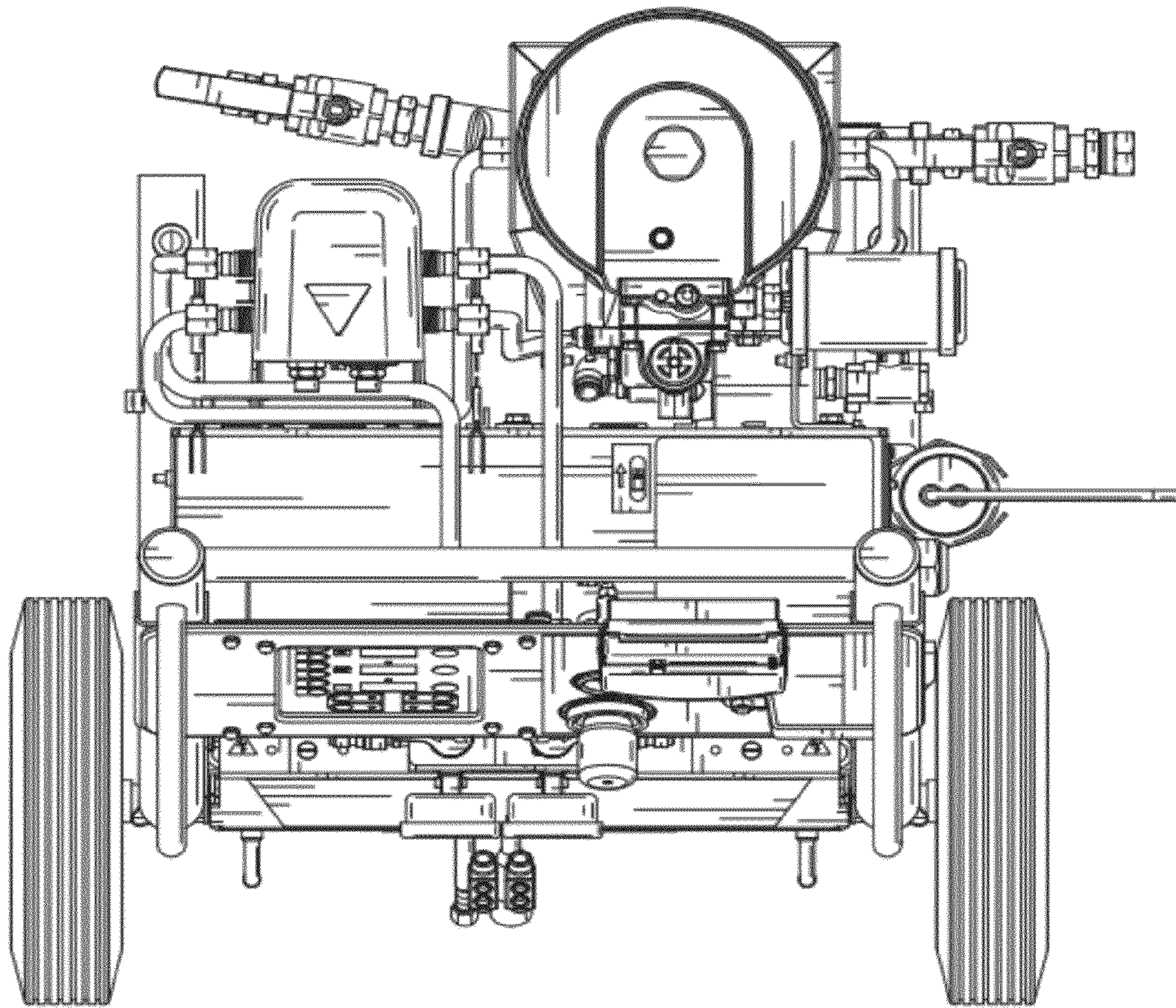
FIG. 1 is a front right isometric view of the portable plural component proportioner;  
FIG. 2 is a top view thereof;  
FIG. 3 is a front view thereof;  
FIG. 4 is a right side view thereof,  
FIG. 5 is a left side view thereof;  
FIG. 6 is a rear view thereof; and,  
FIG. 7 is a bottom view thereof.

**1 Claim, 7 Drawing Sheets**

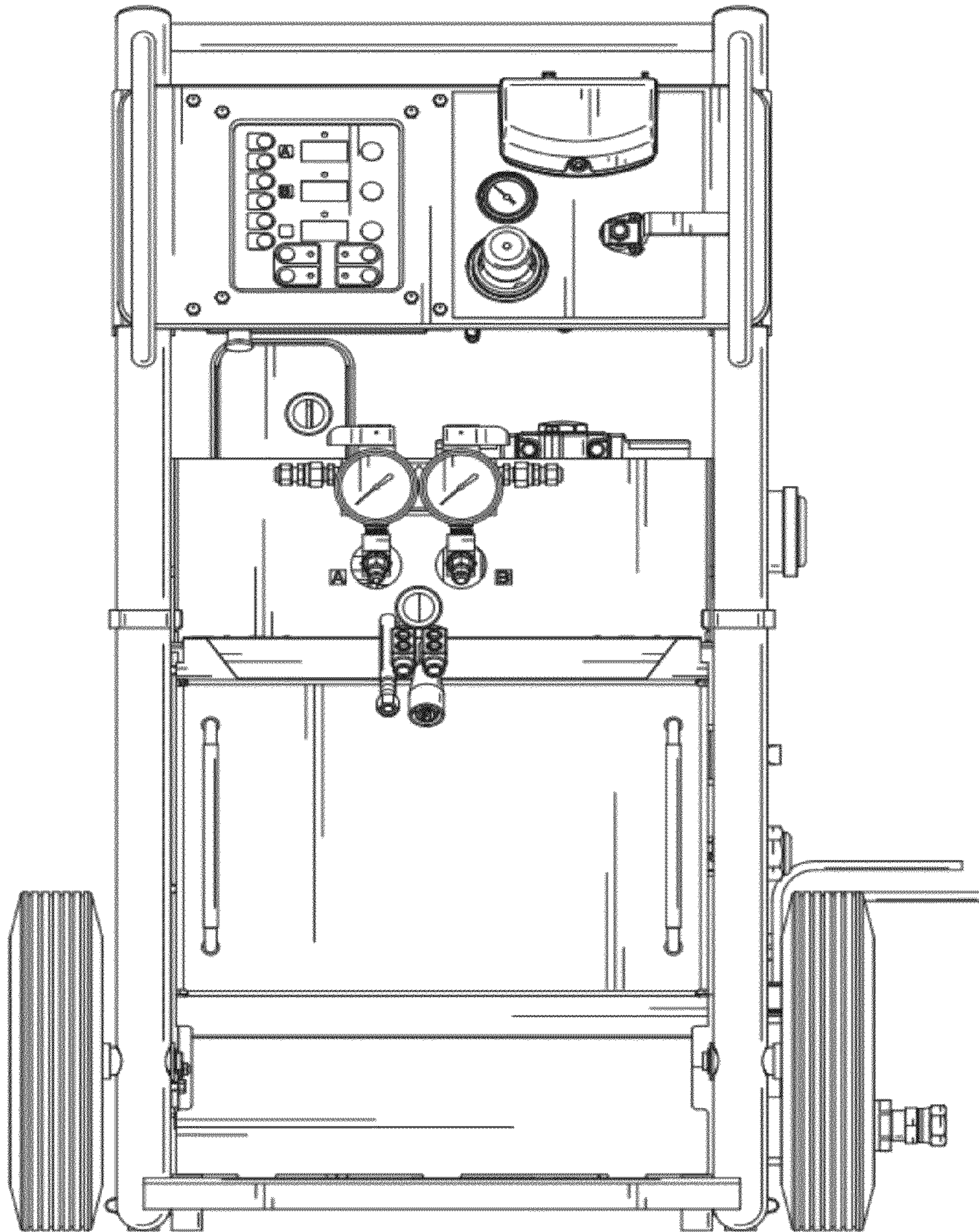




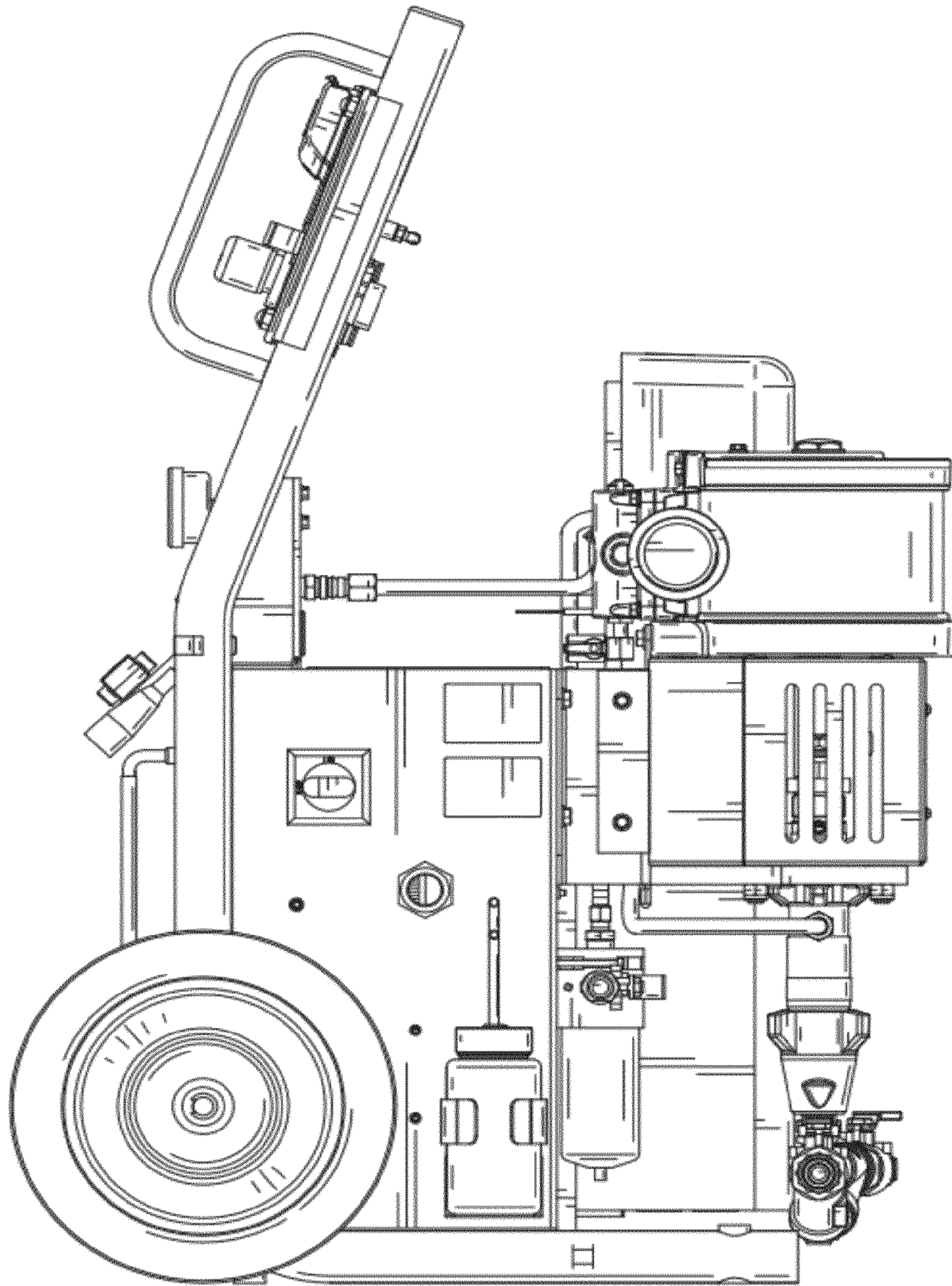
**FIG. 1**



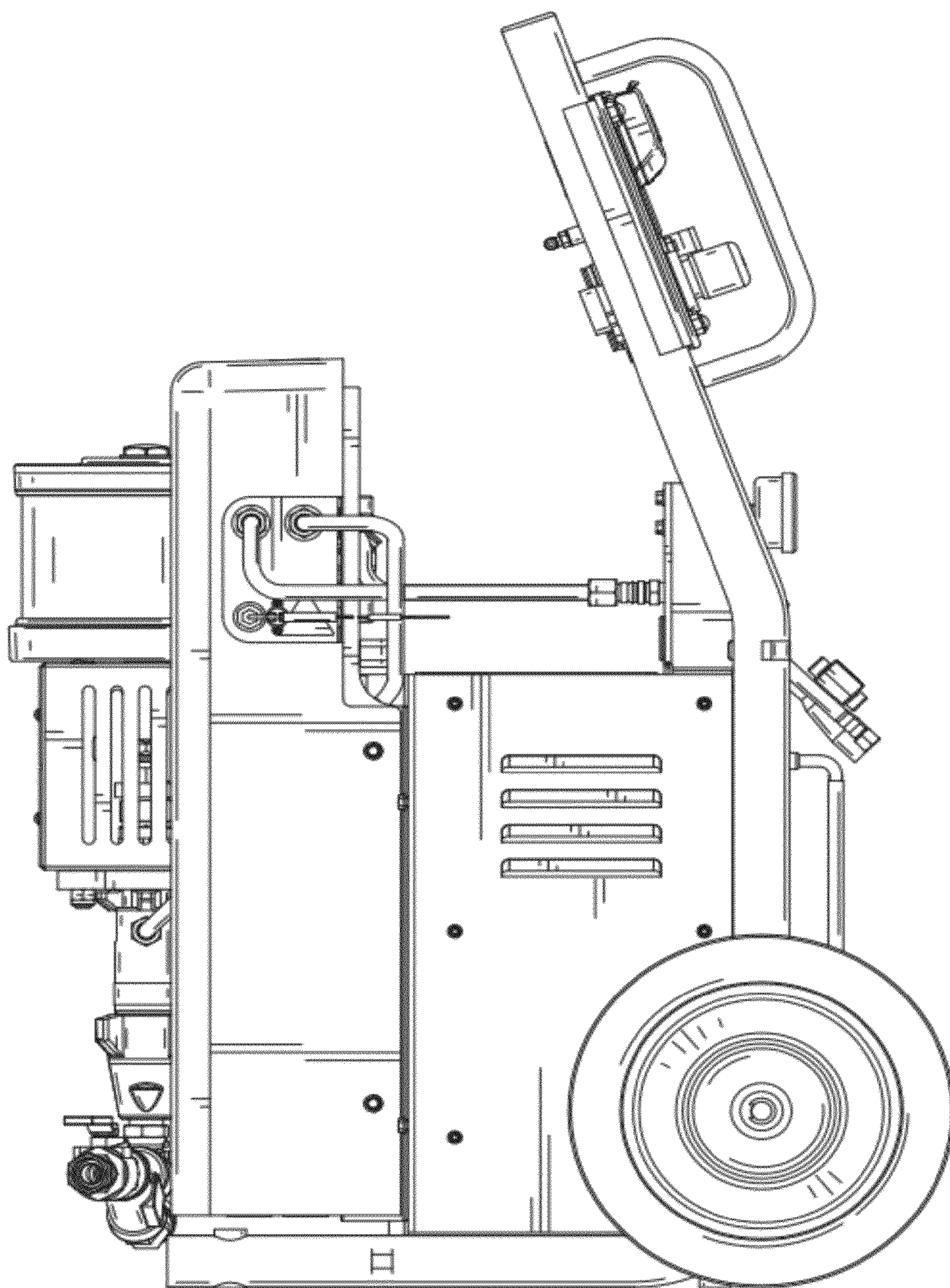
**FIG. 2**



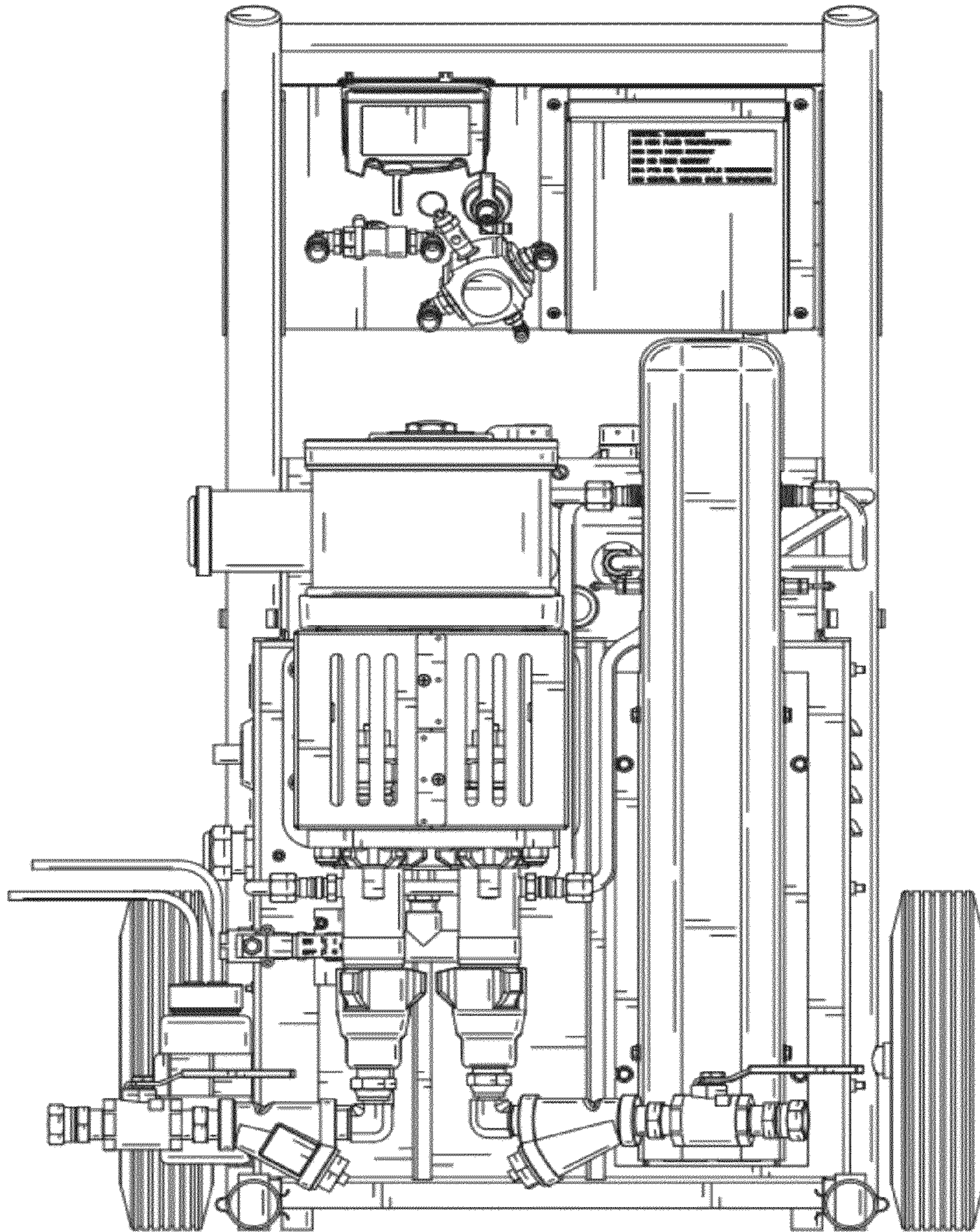
**FIG. 3**



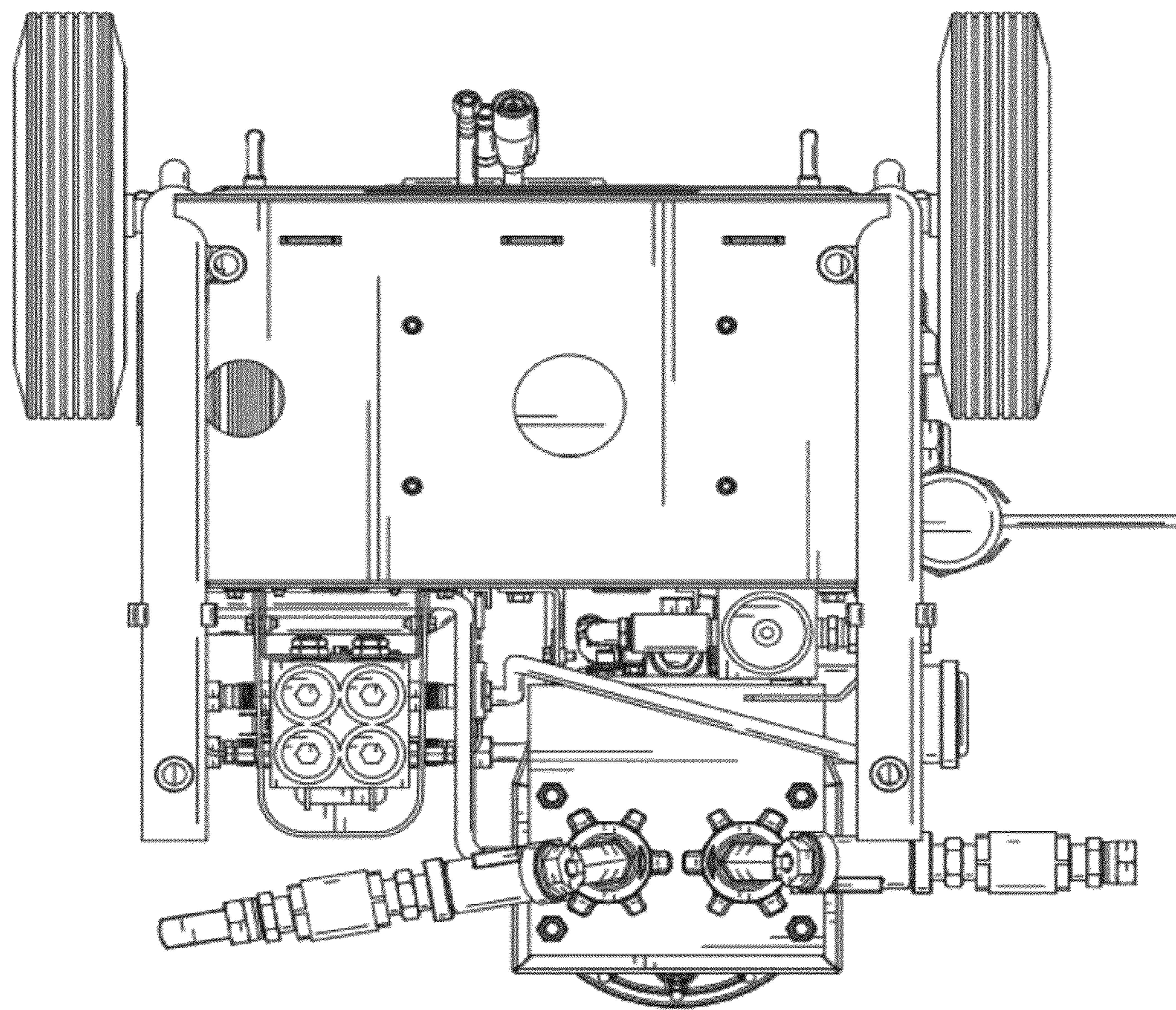
**FIG. 4**



**FIG. 5**



**FIG. 6**



**FIG. 7**