



US00D660791S

(12) **United States Design Patent**  
**Murata et al.**

(10) **Patent No.:** **US D660,791 S**

(45) **Date of Patent:** **\*\* May 29, 2012**

(54) **CHARGER STAND FOR ELECTRIC VEHICLE**

(75) Inventors: **Kazuomi Murata**, Ise (JP); **Akira Ishikura**, Ise (JP)

(73) Assignee: **Sinfonia Technology Co., Ltd.**, Tokyo (JP)

(\*\*) Term: **14 Years**

(21) Appl. No.: **29/381,950**

(22) Filed: **Dec. 27, 2010**

(30) **Foreign Application Priority Data**

Jun. 29, 2010 (JP) ..... JD2010-015802

(51) **LOC (9) Cl.** ..... **13-02**

(52) **U.S. Cl.** ..... **D13/107**

(58) **Field of Classification Search** ..... D13/106–110,  
D13/118–119, 184, 199; D15/9; 320/103–115  
See application file for complete search history.

(56) **References Cited**

**U.S. PATENT DOCUMENTS**

|              |         |                 |       |         |
|--------------|---------|-----------------|-------|---------|
| D257,882 S * | 1/1981  | Rawson et al.   | ..... | D24/186 |
| D596,560 S * | 7/2009  | Cutchins et al. | ..... | D13/108 |
| D608,731 S * | 1/2010  | Amit            | ..... | D13/107 |
| D608,733 S * | 1/2010  | Smith           | ..... | D13/107 |
| D608,734 S * | 1/2010  | Smith           | ..... | D13/107 |
| D613,683 S * | 4/2010  | Baxter et al.   | ..... | D13/107 |
| D618,168 S * | 6/2010  | Baxter et al.   | ..... | D13/107 |
| D626,063 S * | 10/2010 | Cutter et al.   | ..... | D13/107 |

|                   |         |                |       |         |
|-------------------|---------|----------------|-------|---------|
| D626,064 S *      | 10/2010 | Cutter et al.  | ..... | D13/107 |
| D626,065 S *      | 10/2010 | Cutter et al.  | ..... | D13/107 |
| D628,960 S *      | 12/2010 | Shimizu et al. | ..... | D13/107 |
| D629,747 S *      | 12/2010 | Rajakaruna     | ..... | D13/107 |
| D632,645 S *      | 2/2011  | Blain          | ..... | D13/107 |
| 2002/0030466 A1 * | 3/2002  | Tracey         | ..... | 320/104 |

\* cited by examiner

*Primary Examiner* — Rosemary K Tarca

(74) *Attorney, Agent, or Firm* — Oblon, Spivak, McClelland, Maier & Neustadt, L.L.P.

(57) **CLAIM**

The ornamental design for a charger stand for electric vehicle, as shown and described.

**DESCRIPTION**

FIG. 1 is a front, left, and top perspective view of a charger stand for electric vehicle;  
 FIG. 2 is a rear, right, and bottom perspective view thereof;  
 FIG. 3 is a front view thereof;  
 FIG. 4 is a rear view thereof;  
 FIG. 5 is a top view thereof;  
 FIG. 6 is a bottom view thereof;  
 FIG. 7 is a right view thereof;  
 FIG. 8 is a left view thereof;  
 FIG. 9 is a cross-sectional view along line 9-9 from FIG. 3 that omits internal mechanisms; and,  
 FIG. 10 is a cross-sectional view along line 10-10 from FIG. 7 that omits the power cord and internal mechanisms.  
 The broken lines shown in FIGS. 9 and 10 are included for the purpose of illustrating environmental structure and form no part of the claimed design.

**1 Claim, 5 Drawing Sheets**

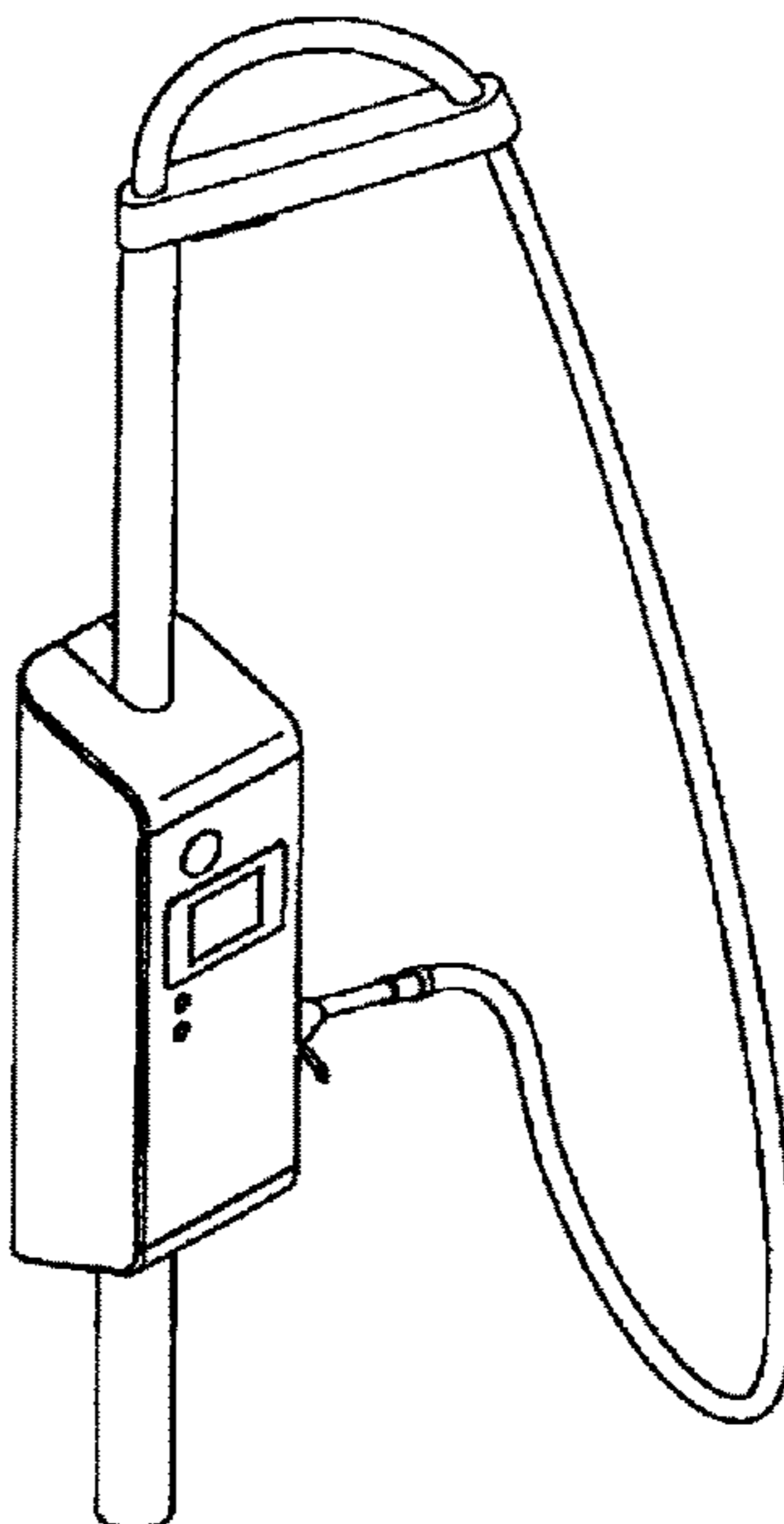

FIG. 1

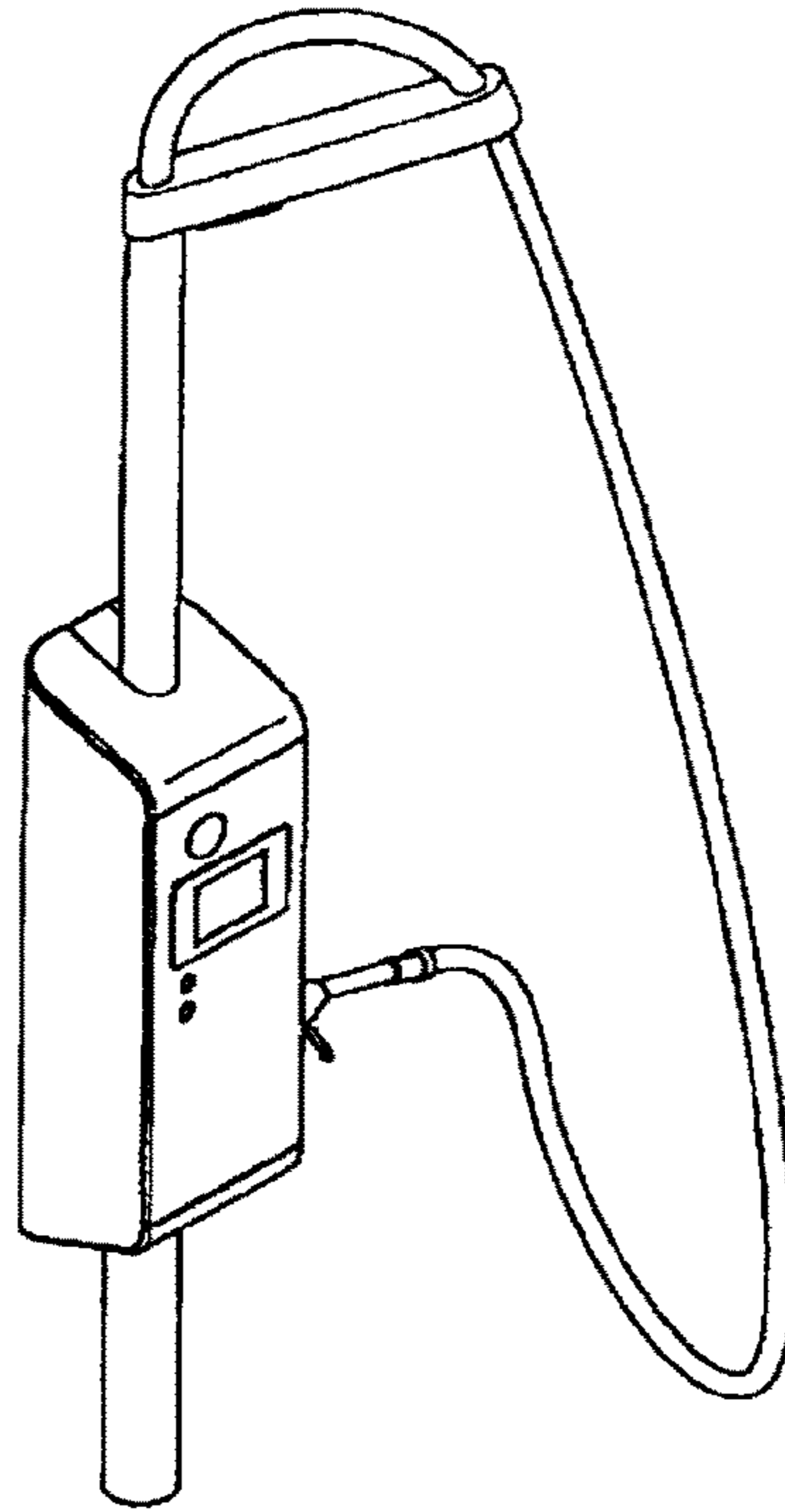

FIG. 2

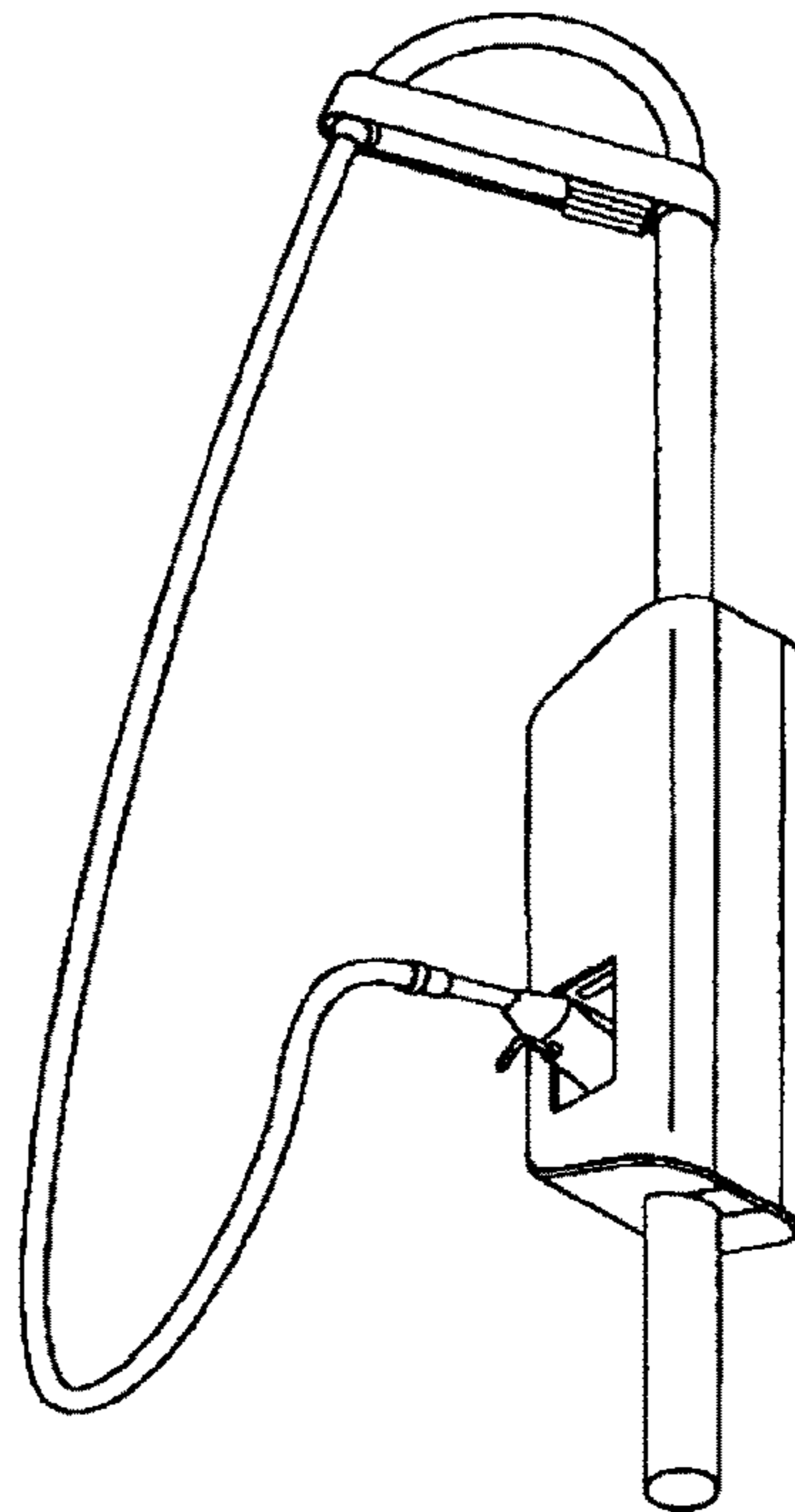

FIG. 3

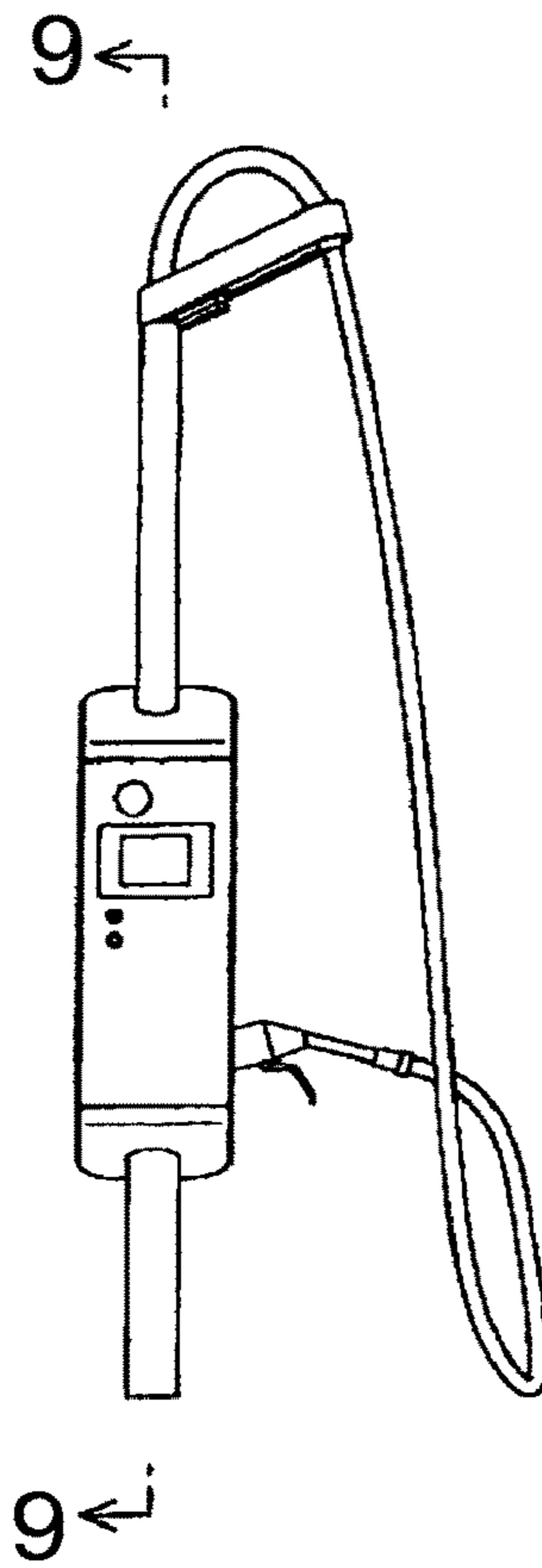

FIG. 4

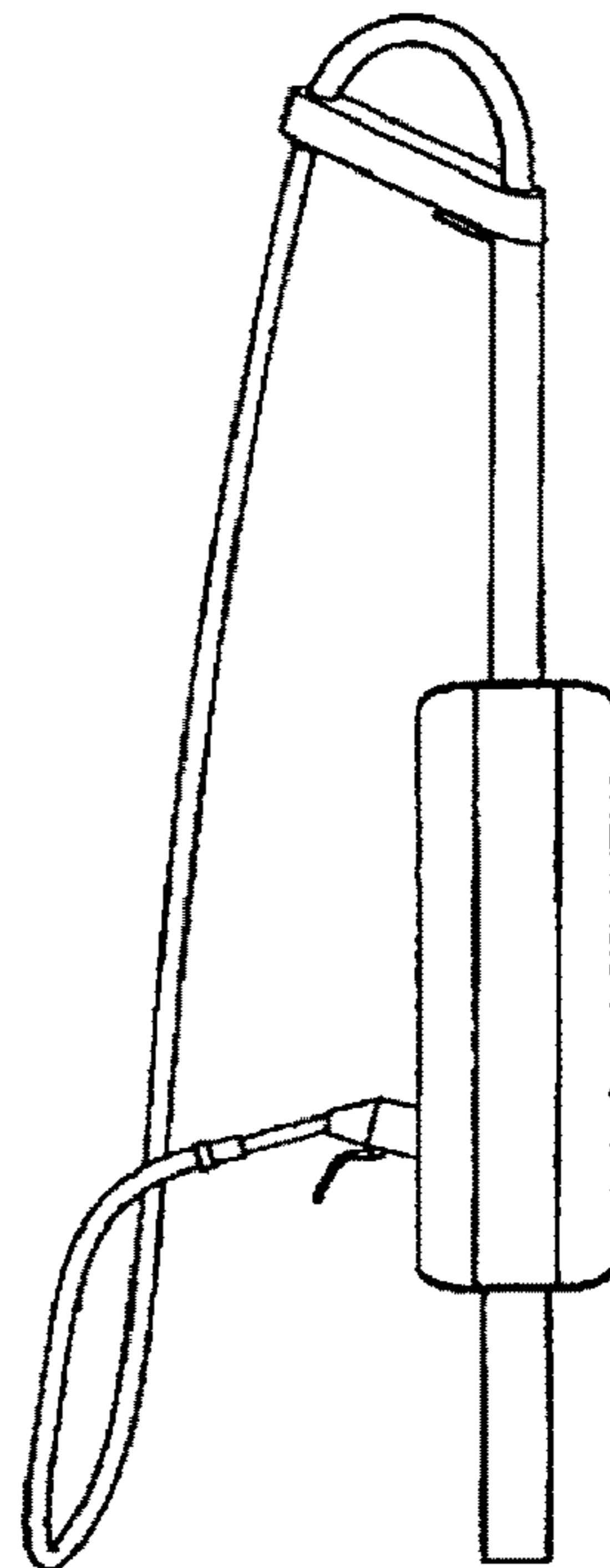

FIG. 5

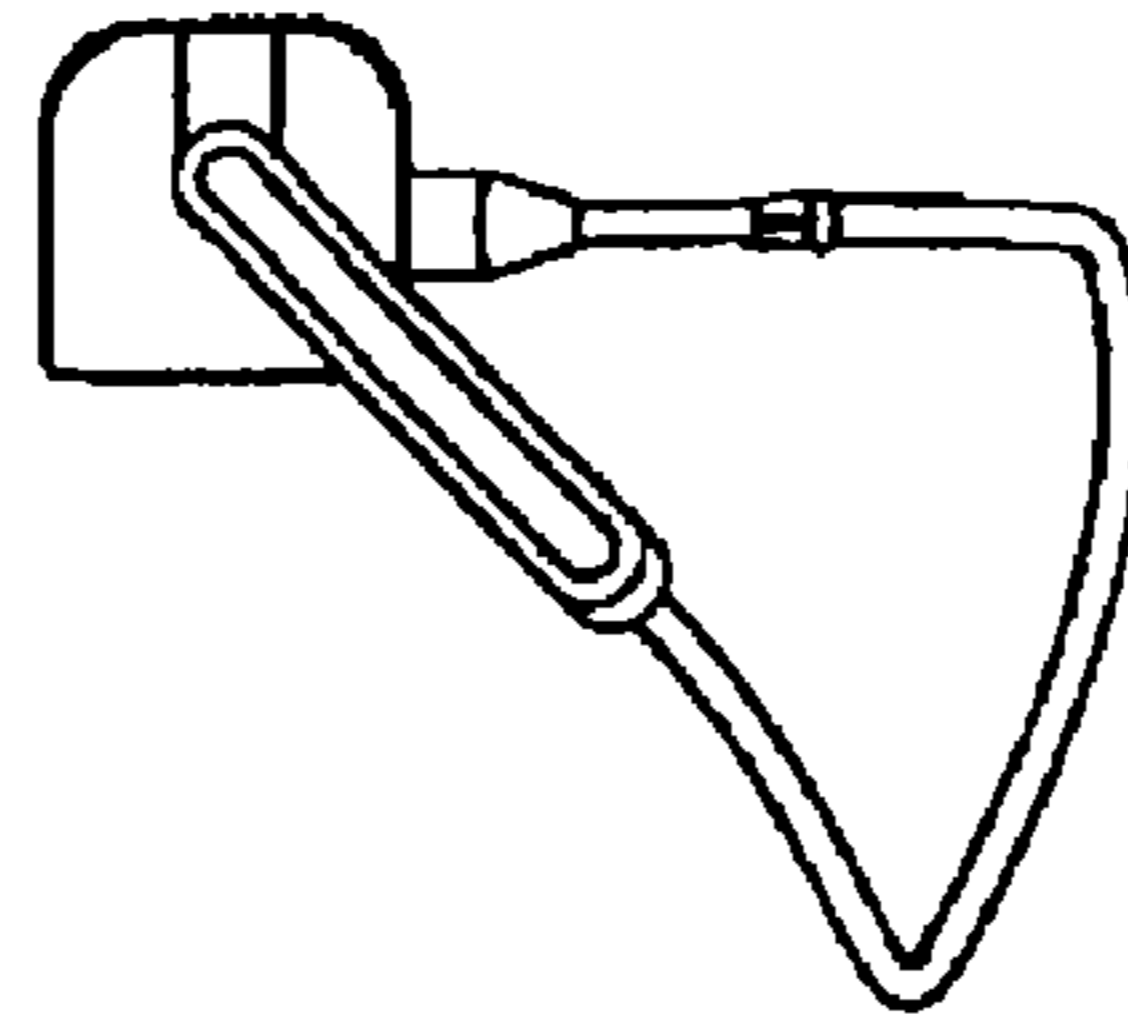

FIG. 6

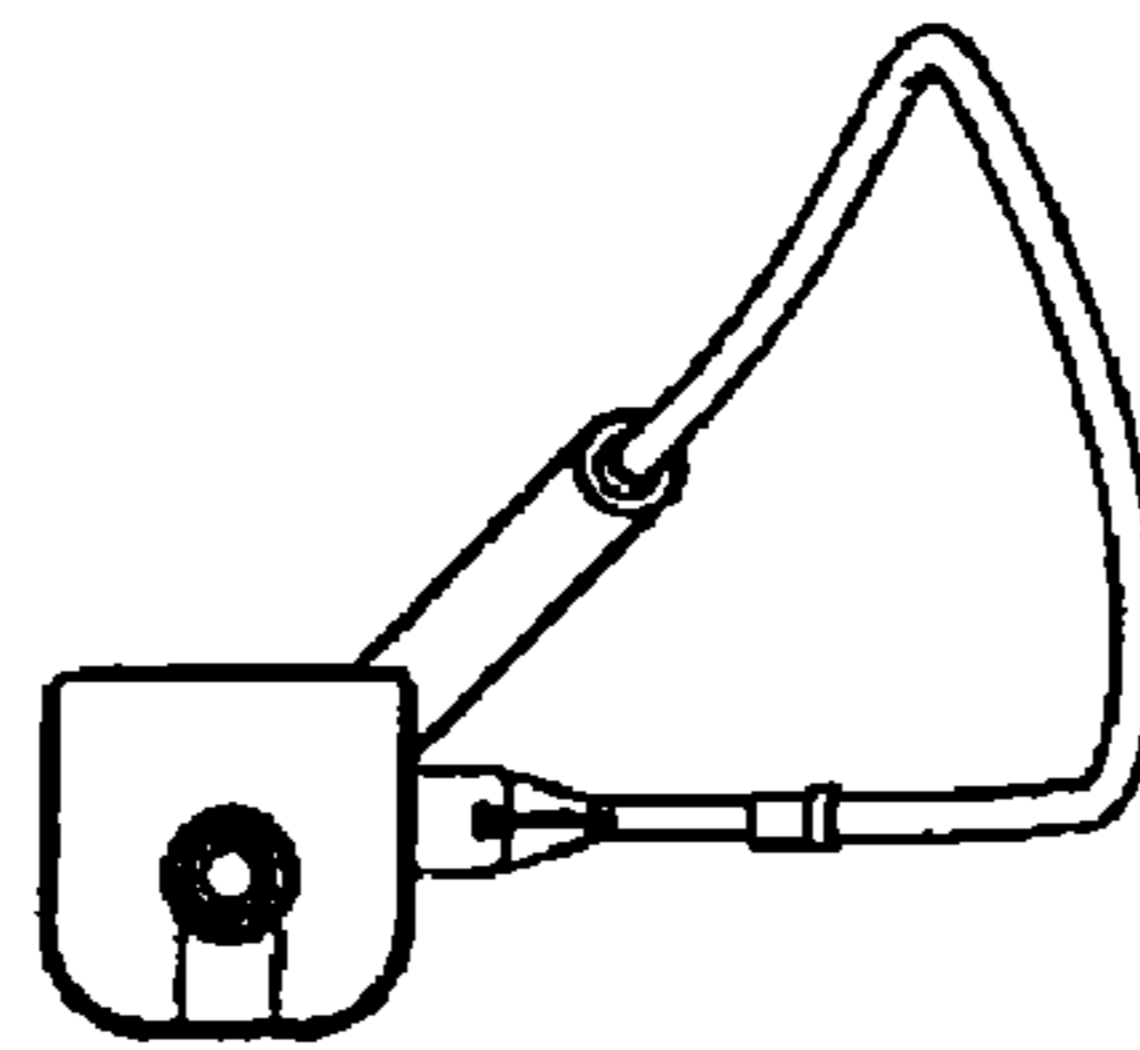
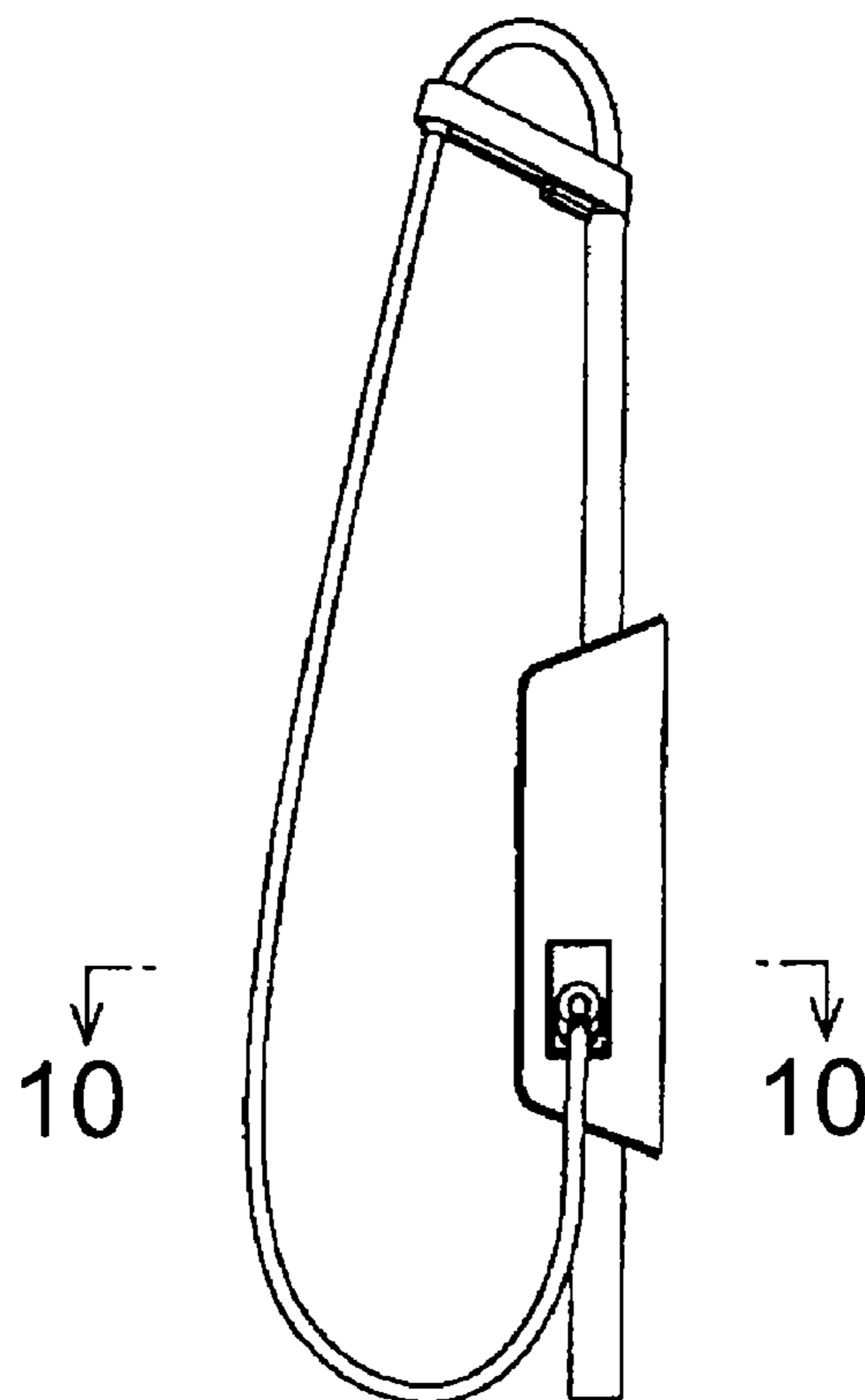
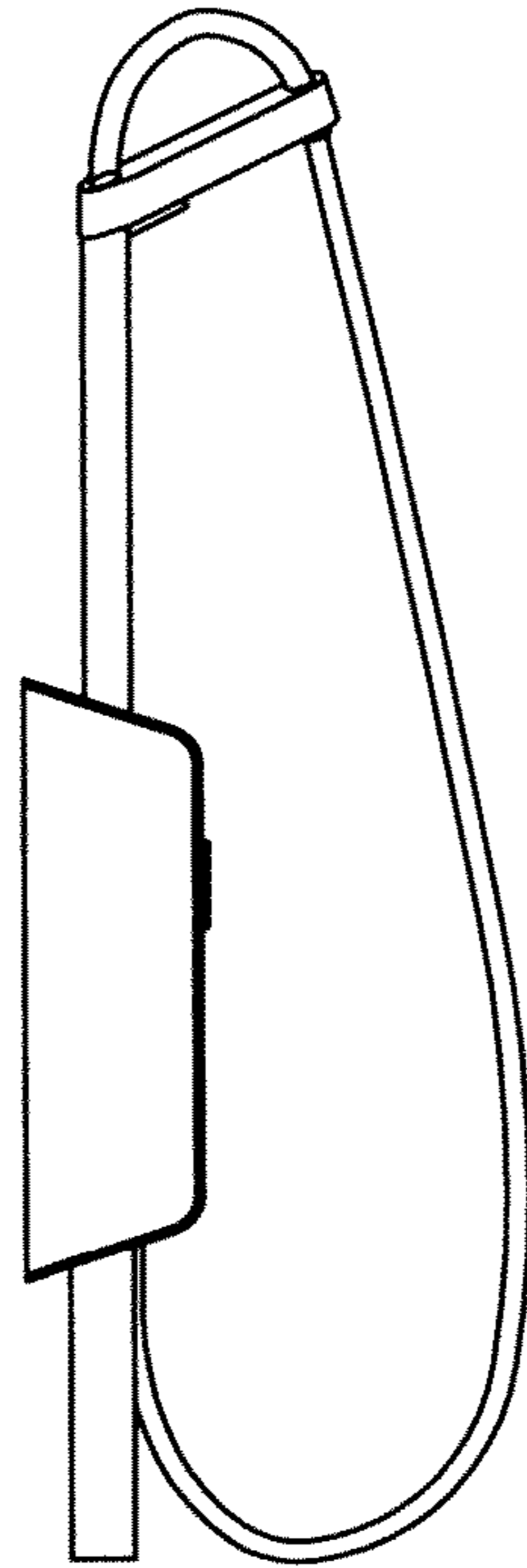

FIG. 7



***Fig. 8***



***Fig. 9***

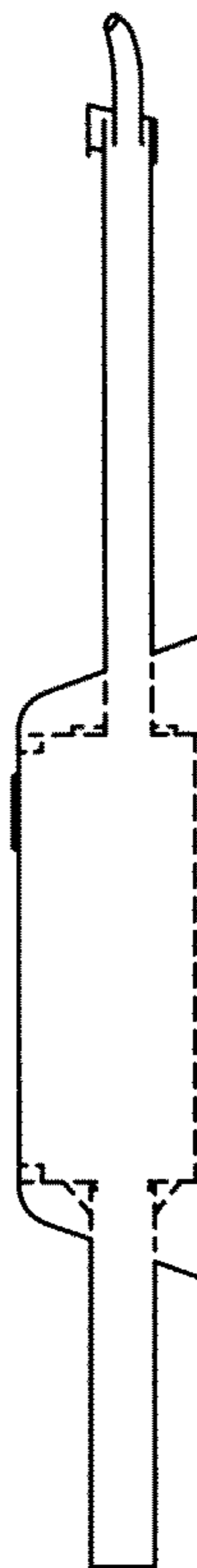

*Fig. 10*

